

Operating Manual

Mark Levinson®
N° 27
Dual Monaural
Power Amplifier

Madrigal Audio Laboratories, Inc.

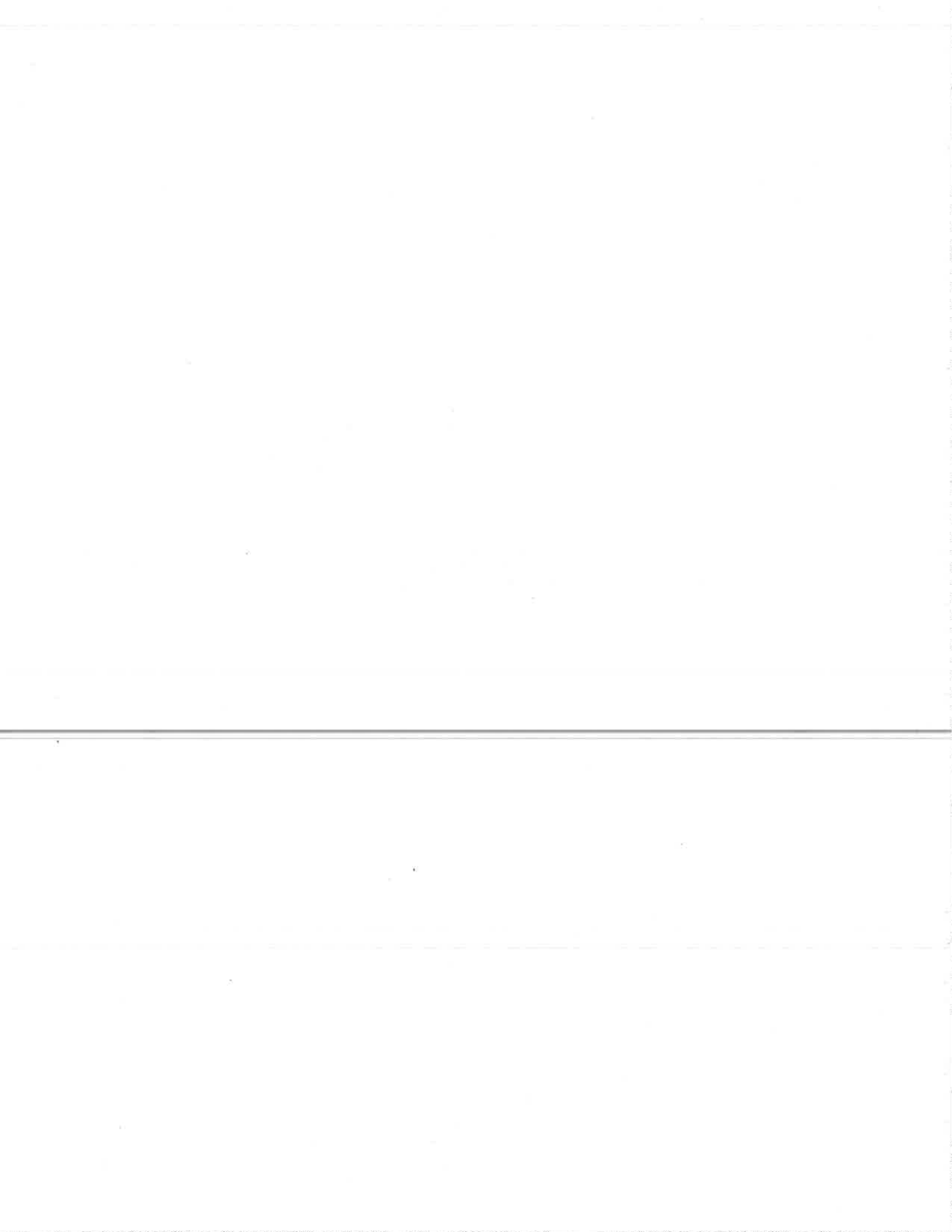

Important safety instructions

Please read all Instructions and precautions carefully and completely before operating your N° 27 Dual Monaural Power Amplifier.

1. **ALWAYS** disconnect your entire system from the AC mains before connecting or disconnecting any cables, or when cleaning any component.
2. This product is equipped with a three-conductor AC mains power cord which includes an earth ground connection. To prevent shock hazard, all three connections must **ALWAYS** be used. If your electrical outlets will not accept this type of plug, an adapter may be purchased. If an adapter is necessary, be sure it is an approved type and is used properly, supplying an earth ground. If you are not sure of the integrity of your home electrical system, contact a licensed electrician for assistance.
3. AC extension cords are not recommended for use with this product. If an extension cord must be used, be sure it is an approved type and has sufficient current-carrying capacity to power this product.
4. **NEVER** use flammable or combustible chemicals for cleaning audio components.
5. **NEVER** operate this product with any covers removed.
6. **NEVER** wet the inside of this product with any liquid.
7. **NEVER** pour or spill liquids directly onto this unit.
8. **NEVER** block air flow through ventilation slots or heatsinks.
9. **NEVER** bypass any fuse.
10. **NEVER** replace any fuse with a value or type other than those specified.
11. **NEVER** attempt to repair this product. If a problem occurs, contact your Mark Levinson® retailer.
12. **NEVER** expose this product to extremely high or low temperatures.
13. **NEVER** operate this product in an explosive atmosphere.
14. **ALWAYS** keep electrical equipment out of the reach of children.



From all of us at Madrigal Audio Laboratories, thank you for choosing the Mark Levinson® N° 27 Dual Monaural Power Amplifier.

A great deal of effort went into the design and construction of this precision device. If used properly, it will give you many years of enjoyment.

Table of Contents

Unpacking	2
Location	2
Installation	3
Voltage selection	3
Connectors	3
Signal connection	4
Speaker connections	6
Power connection	8
Bridged operation	8
Care and maintenance	10
Circuit description	11
Specifications	13
Dimensions	14
Service	15
LIMITED FIVE-YEAR WARRANTY	16
Illustrations	
Figure 1: Rear panel	3
Figure 2: Connections for single-ended normal (non-inverting) operation	4
Figure 3: Female input connector	4
Figure 4: Connections for single-ended inverting operation	5
Figure 5: Connections for balanced normal (non-inverting) operation	5
Figure 6: Spade and hook lugs	6
Figure 7A: Pigtail connection	6
Figure 7B: Pigtail connection	7
Figure 7C: Pigtail connection	7
Figure 8: Connections for bridged operation	8
Figure 9: Bridging cable	9
Figure 10A: Dimensions, top view	14
Figure 10B: Dimensions, side view	14

Unpacking

Unpack your N° 27 amplifier and keep all packing materials for future transport. Because of the weight of the unit, handles have been provided front and rear so two people may lift and carry the amplifier comfortably and without risk of injury.

Carefully inspect the product for damage and flaws. If any are found, contact your Mark Levinson retailer immediately.

Location

Placement To keep speaker cable lengths as short as possible, locate the N° 27 as close to the loudspeakers as practical.

The N° 27 should be located at least three feet away from the turntable and preamplifier. Otherwise, the N° 27 may induce hum from these sensitive components.

Ventilation The N° 27 may be placed in a cabinet or on a shelf, but adequate ventilation must be provided to prevent overheating. The clearance provided by the unit's feet must be maintained to ensure unrestricted air flow through the heatsinks and vents in the bottom of the chassis. Clearance above the unit must also be maintained to allow air circulation and to prevent heat buildup.

The N° 27 incorporates thermal sensors located near each group of output devices. If the heatsink temperature becomes excessive, these sensors will shut off the amplifier before damage results. After a brief cooling period, the amplifier can be reactivated via the front panel switch. If this occurs regularly during normal use, it is an indication that the ventilation provided for the amplifier is inadequate.

Installing the N° 27 in a cabinet

For those persons involved in custom installations and cabinet work, the following information may be useful.

- All temperature measurements are made at the top of the heatsink, 3.5 inches behind the front plate.
- Normal heatsink temperature at idle after warmup with unrestricted airflow: 36°C – 38°C.
- Maximum permissible heatsink temperature before thermal protection is activated: 80°C.

A mechanical drawing is included in this manual to facilitate special installations and custom cabinet work (see "Dimensions," Figure 10A and Figure 10B).

Installation

Precautions For your protection, please review "Important safety instructions" before you install your N° 27.

Voltage selection

The N° 27 can be internally set for 100, 120, 200, 220, or 240VAC mains operation. Check that the label on the rear panel of the amplifier indicates the correct AC operating voltage for your location (refer to Figure 1). A N° 27 may be powered by a 15-ampere AC mains line. If other devices are also powered from the same AC feed, their additional power consumption must be considered.

Figure 1: Rear panel

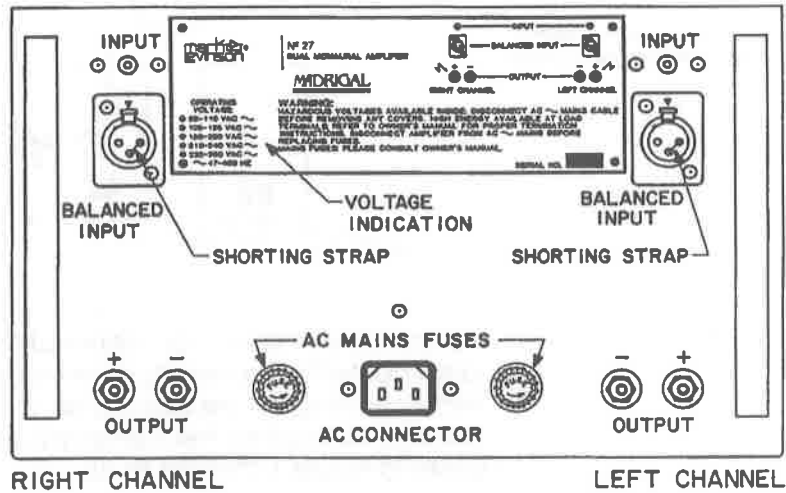

If you wish to change the AC operating voltage of your N° 27, contact your Mark Levinson retailer for assistance.

Connectors

The N° 27 incorporates Camac and XLR-type connectors for audio signal input.

Camac connectors

The Camac connector is a precision, high-reliability device used as a standard by the European Center for Nuclear Research. Detailed information about the Camac system is available from your Mark Levinson retailer.

XLR-type connectors

The gold-plated XLR-type connector employed is of European design, and is made to professional application standards.

A wide variety of Camac connectors, XLR-type connectors, and interconnect cables are available from your Mark Levinson retailer to facilitate virtually any installation.

Signal connection

The N° 27 can be operated in either single-ended or balanced mode. In each of these modes, the N° 27 can be operated either normally (non-inverting) or inverting.

This manual describes the connections for single-ended normal (non-inverting), single-ended inverting, and balanced normal (non-inverting) operation. If you have questions about these or other methods of signal connection, see your Mark Levinson retailer.

Single-ended normal (non-inverting) operation

Figure 2: Connections for single-ended normal (non-inverting) operation

Connections for single-ended normal (non-inverting) operation:

Typical audio systems require that the amplifier be of the non-inverting type. This means that the output signal of the amplifier will be in phase with the input signal.

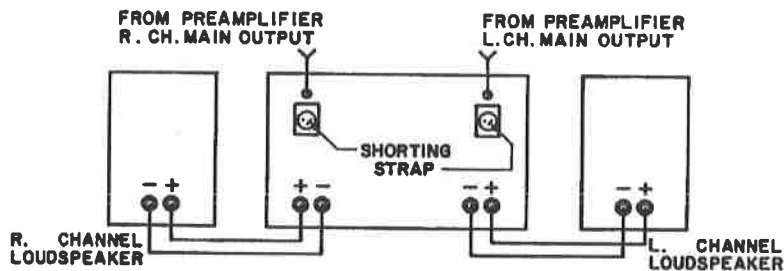

For this type of operation, connect the main outputs of the preamplifier to the appropriate (left and right channel) Camac inputs (non-inverting) on the rear panel of the N° 27. Be sure that the shorting strap is inserted into the XLR-type connectors between pins 1 and 3 (refer to Figure 1 and Figure 2).

Single-ended inverting operation

Connections for single-ended inverting operation: Inverting operation should be used if a phase reversal is required. In this mode of operation, the output signal of the amplifier will be 180 degrees out of phase with the input signal. This may be required if one component in the system inverts the signal and absolute phase at the loudspeaker is desired. For inverting operation, the main output cables of the preamplifier must be connected to the XLR-type input connectors at the rear of the N° 27. The pin assignments of these connectors are (refer to Figure 3):

Figure 3: Female input connector

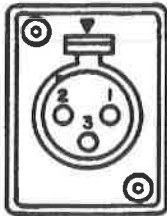

- Pin 1: Signal ground
- Pin 2: Signal "+" (Non-inverting)
- Pin 3: Signal "-" (Inverting)
- Connector ground lug: Chassis ground

Connect the XLR-type male line mount connector to the preamplifier main output cable so that signal "hot" (+) connects to Pin 3 and signal ground connects to Pin 1. Be sure to also connect Pin 2 to Pin 1 inside the XLR-type male line mount connector with a piece of copper buss wire (or similar material) at the amplifier end of the cable.

Note: If you prefer not to connect Pin 2 to Pin 1 inside the XLR-type male line mount connector, you may purchase pre-shorted Camac input connectors (Madrigal Part #65-0010-00-SP-00) from your Mark Levinson retailer. These parts should be inserted into each of the Camac inputs (non-inverting) on the rear panel of the N° 27.

After completing the cables, connect the main outputs of the preamplifier to the appropriate (left and right channel) XLR-type input connectors on the rear panel of the N° 27. Be sure to remove the shorting strap between Pins 1 and 3 before inserting the output cable connectors (refer to Figure 1 and Figure 4).

Figure 4: Connections for single-ended inverting operation

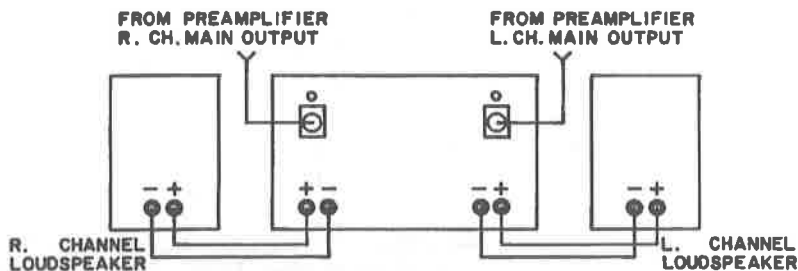

Balanced normal (non-inverting) operation

Connections for balanced normal (non-inverting) operation: If your preamplifier is equipped with a balanced main output, it is advantageous to wire the N° 27 for balanced operation, particularly if long cable lengths are required between the preamplifier and the N° 27. Refer to Figure 3 for the pin assignments of the XLR-type input connectors at the rear of the N° 27.

Connect the XLR-type male line mount connector to the preamplifier main output cable according to Figure 3, carefully observing pin number assignments. Refer to your preamplifier's operating manual to verify that the pin assignments of its output connector correspond to the diagram above. If they do not, wire the connector so that the appropriate output pin connects to the equivalent input pin. When complete, connect the main outputs of the preamplifier to the appropriate (left and right channel) XLR-type input connectors on the rear panel of the N° 27. Be sure to remove the shorting strap between Pins 1 and 3 before inserting the output cable connectors. For proper balanced operation, no connector (pre-shorted or otherwise) should be inserted into the Camac inputs at the rear of the N° 27 (refer to Figure 1 and Figure 5).

Figure 5: Connections for normal (non-inverting) balanced operation

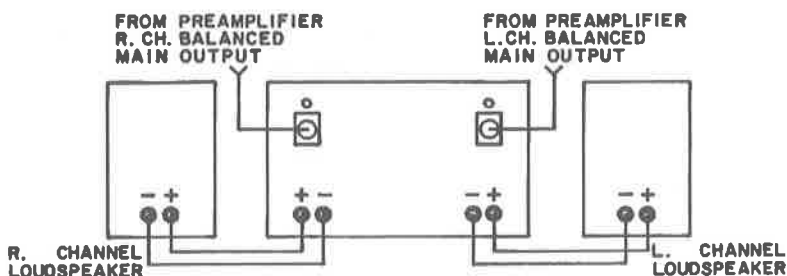

Speaker connections

Precautions **NEVER** connect the N° 27 output terminals to any device other than a loudspeaker.

NEVER short-circuit the amplifier output terminals.

NEVER connect the left channel output terminals to the right channel output terminals.

The N° 27 is equipped with gold-plated, high-current, five-way binding posts for output termination to a loudspeaker system. To take full advantage of the sonic quality of the N° 27, we recommend that high-quality speaker cable be used. Consult your Mark Levinson retailer for recommendations.

Connection methods There are two recommended methods for connecting speaker cables to the outputs of the N° 27. A high quality spade or hook-type lug, soldered to the cable, is preferred. We confidently recommend Madrigal binding post lugs, made of oxygen-free copper with gold-over-silver plating. These lugs are available for round cable (Madrigal Part #65-0901-70-00-00); see your Mark Levinson retailer for more information.

Figure 6: Spade and hook lugs



Many lug connectors are designed to be crimped onto the cable. However, soldering will ensure a better electrical connection.

Note: If you have no experience in soldering, please contact your representative for assistance.

Pigtail connection The "pigtail" is another method of connection which uses a short piece of 14-gauge wire soldered to the speaker cable. The other end of this 14-gauge wire is inserted through the hole in the five-way binding posts on the rear panel of the N° 27.

1. Begin with 3" of 14-gauge copper wire.
2. Strip 5/8" of insulation from one end, and strip 1/2" of insulation from the opposite end (refer to Figure 7A).

Figure 7A: Pigtail connection

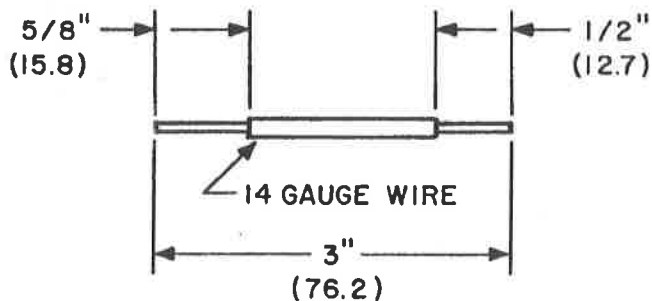

3. Strip 1/2" of insulation from the speaker cable.
4. Gently slide the (5/8") bare end of the 14-gauge wire into the center of the bare speaker cable (refer to Figure 7B; be careful not to spread the individual wires of the speaker cable).

Figure 7B: Pigtail connection

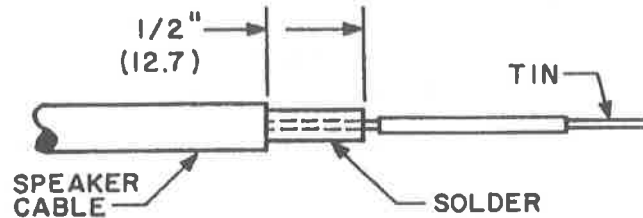

5. Solder this connection (refer to Figure 7B). A high-wattage soldering gun may be necessary to provide adequate heat.
6. Lightly "tin" the remaining (1/2") bare end of the 14-gauge wire.
7. Gently slide a 1" length of shrink tubing (5/8" diameter tubing for HF10C) over the connection and heat to shrink (refer to Figure 7C). Colored shrink tubing is available for polarity identification.

Figure 7C: Pigtail connection

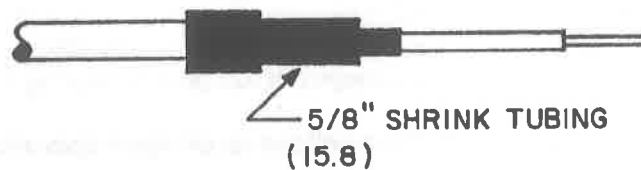

8. Follow this procedure for the three remaining speaker connections.

This procedure may also be used for the speaker end of the cable, depending upon the type of speaker terminal.

Connecting the speakers

When the speaker cables are complete, connect the left channel "+" (positive or red) output post of the № 27 to the "+" (positive or red) input terminal of the appropriate loudspeaker. Connect the left channel "-" (negative or black) output post of the № 27 to the "-" (negative or black) input terminal of the appropriate loudspeaker (refer to Figure 1 and Figure 2). Repeat this procedure for the right channel.

Power connection

Connecting the AC power cord

After your loudspeaker connections have been made, apply power to your preamplifier and allow it to stabilize (Mark Levinson preamplifiers, for example, require approximately one minute to stabilize).

Connect the AC power cord (included in the accessory pack) to the AC connector on the rear panel of the N° 27, then to the AC mains outlet (refer to Figure 1).

The N° 27 may now be turned on.

Bridged operation

When greater power output is desired, the N° 27 may be bridged for monophonic operation into load impedances of at least 2 ohms.

Note: Make sure the loudspeaker is rated to handle extremely high power levels. For example, a bridged N° 27 driving an 8-ohm loudspeaker is capable of delivering 400 watts RMS.

When planning to use N° 27 amplifiers in the bridged mode with loudspeakers that are biamp-able, we strongly recommend purchasing a high quality electronic crossover (such as the Mark Levinson LNC-2) and operating in the biamp mode.

Connections for bridged operation

1. Connect the appropriate channel of the preamplifier's main output to the left channel Camac input (non-inverting) on the rear panel of the N° 27 (refer to Figure 8).

Figure 8: Connections for bridged operation

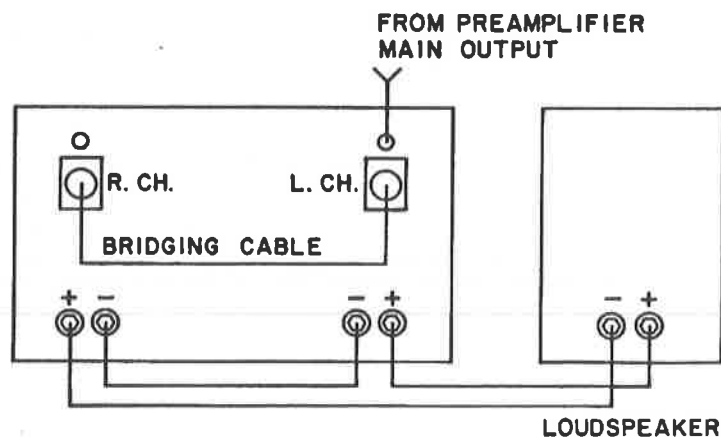

Bridging cables

2. Connect the bridging cable between the left and right channel XLR-type input connectors, taking care to insert the correct cable end into its designated channel (refer to Figure 8). This cable can be assembled as shown in Figure 9, or obtained through your Mark Levinson retailer as part of a N° 27 Bridging Kit (Madrigal Part #76-4330-00-00-00).

Figure 9: Bridging cable

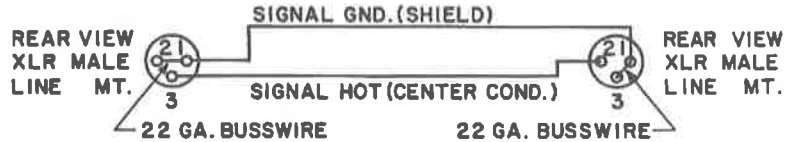

Note: If assembling the bridging cable, be sure to use high quality audio interconnect cable (such as Madrigal HPC cable).

3. Connect the shortest possible length of heavy-gauge, high quality speaker cable (such as Madrigal CPC cable) between the left and right channel "-" (negative or black) output posts of the N° 27 (refer to figure 8).
4. Connect the left channel "+" (positive or red) output post of the N° 27 to the "+" (positive or red) input terminal of the appropriate loudspeaker. Connect the right channel "+" (positive or red) output post of the N° 27 to the "-" (negative or black) input terminal of the same loudspeaker (refer to Figure 8).
5. Repeat this procedure for the other N° 27 to be bridged.

Care and Maintenance

Cleaning To remove dust from the cabinet of the N° 27, use a feather duster. To remove dirt and fingerprints, we recommend isopropyl alcohol and a soft cloth.

Poor connections cause sonic degradation. We recommend, therefore, that you clean all speaker connection with denatured alcohol at least once a year. Consult your Mark Levinson retailer for other ways to optimize connections.

Fuses Two slow-blow 250V 3AG fuses (10 ampere @100, 120VAC and 6.25 ampere @200, 220, 240VAC) are located on the rear panel of the N° 27 (refer to Figure 1). **ALWAYS** remove the AC cord before removing the fuses. Replace the fuses with the same type only.

Circuit description

Unregulated power supplies

The N° 27 uses two completely independent power supplies, one per channel. Each of these supplies, in turn, consists of two power supplies:

- **High-current output stage supply:** Composed of a custom-made 729VA toroidal power transformer, a 35-ampere bridge rectifier, and two 45,000 μ f filter capacitors. Each of the filter capacitors is further bypassed on the audio printed circuit board with switch-mode electrolytic and film-type capacitors.
- **Low-current pre-regulated supply:** Consists of two separate 34VA secondary windings from the toroidal power transformer, a discrete bridge rectifier, and two 1900 μ f filter capacitors which are further bypassed on the audio printed circuit board with switch-mode electrolytic and film-type capacitors.

Regulated power supplies

Each low-current pre-regulated supply is further conditioned by a separate electronic regulation circuit. This circuit consists of three common emitter amplifiers providing voltage and current gain for the required 65V, 118MA output. On-board voltage sensing provides negative feedback error correction utilizing operational amplifier techniques. The regulating system is completely discrete, independent-tracking, and prevents the resulting DC voltage rails from fluctuating due to severe current demands from the output stage or changes in the AC mains voltage. In addition to the substantial amount of ripple and AC mains interference rejection this system provides, the regulated DC voltage rails are further filtered by switch-mode electrolytic capacitors bypassed with various film-type capacitors. These stable, noise-free, and ripple-free DC voltage rails are used to power the highly sensitive voltage gain stages of the N° 27.

Voltage gain stage

The voltage gain stage consists of a differential amplifier with a cascode. This stage drives a second differential amplifier with a cascode and a current mirror. Discrete current sources are used throughout. The current mirror converts from balanced to ground (differential) to unbalanced to ground while maintaining push-pull operation. An advanced circuit controls the clipping characteristics of these stages by reducing the amount of harmonics generated. Also incorporated is circuitry which prevents transients produced during turn-on/turn-off from reaching the loudspeakers. To optimize linear performance, all voltage gain and driver stages maintain Class A operation at all levels.

Driver stage

The driver stage consists of a complementary emitter follower driving a second complementary parallel emitter follower.

Output stage

The output stage consists of four parallel complementary push-pull emitter follower pairs.

Protection The N° 27 combines a comprehensive fusing system, electronic protection circuitry, and a custom-made relay-trip on/off switch to protect itself and your loudspeakers if a malfunction occurs. These systems constantly monitor the following operating parameters:

- AC mains current
- Amplifier temperature
- DC offset level
- Power dissipation in the output stage, phase angle dependent
- Short circuit at the output

Additional The N° 27 Dual Monaural Power Amplifier is capable of revealing extremely subtle nuances and details in recorded music. To maximize the performance of your audio system, be sure to carefully set up and optimize all associated components and interconnections in the reproduction chain. Your Mark Levinson retailer, through experience and highly specialized training in the art of music reproduction, can provide valuable advice and assistance in creating a music system able to evoke emotional pleasure through the accurate reproduction of a musical event.

Specifications

The correlation between published specifications and sonic quality is unreliable. A list of numbers reveals virtually nothing. All technical measurements must be subject to qualitative as well as quantitative interpretation.

Measurements of the N° 27 yield excellent results by any standards. However, only those specifications that apply to the actual operation of the amplifier are included here.

- **Rated power:** 100 watts minimum continuous sine wave power into 8 ohms, with both channels driven from 20Hz to 20KHz with no more than 0.1% THD (FTC). 200 watts minimum continuous sine wave power into 4 ohms with both channels driven from 20Hz to 20KHz with no more than 0.2% THD (FTC).
- **Peak output voltage:** 48 volts @ rated line voltage @ 8 ohms
- **Frequency response:** (-3dB) 4Hz, 122KHz
- **Input impedance:** 50K ohms shunted by 1.5nF
- **Voltage gain:** 26dB
- **Power consumption:** Typically 175 watts @ idle, 400 watts @ rated power, 8 ohms
- **Overall dimensions:** See "Dimensions"
- **Shipping weight:** 85 lbs. (38.5 kg)
- **Connector complement:** Two Camac coaxial connectors
Two XLR-type connectors
Four five-way binding posts
One IEC mains connector

For more information, consult your Mark Levinson retailer or:

Madrigal Audio Laboratories, Inc.
Manufacturer of Mark Levinson® Products
2081 South Main Street (Route 17)
P. O. Box 781
Middletown, Connecticut 06457 U.S.A.

Telephone: (203) 346-0896 or 344-9300
ITT Telex: 4942158
Fax: (203) 346-1540

Dimensions

Figure 10A: Dimensions, top view

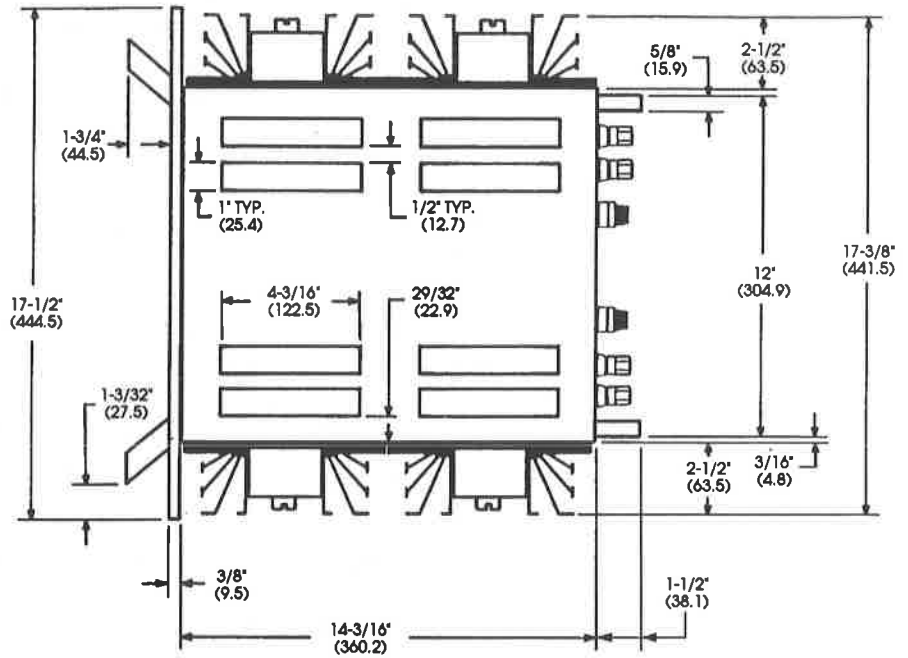
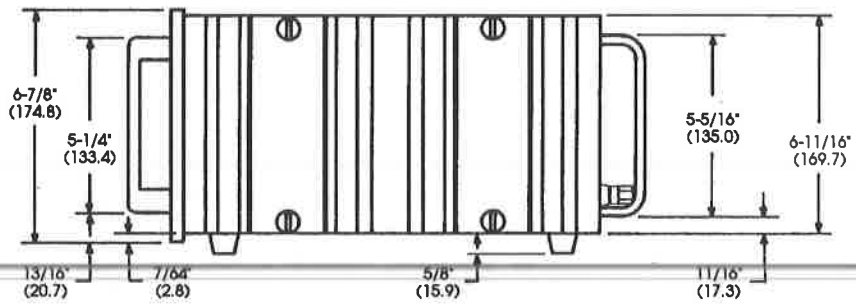

Figure 10B: Dimensions, side view



Service

We take great pride in our distributors and retailers. Experience, dedication, and integrity make these professionals ideally suited to assist with our customers' needs.

Madrigal's Technical Services Department is set up to solve technical problems with maximum efficiency. Its philosophy is based on the knowledge that you have made a substantial investment in order to obtain audio equipment of exceptional quality. It is the intent of the Technical Services Department to provide service to match that investment.

Return authorization

In the event that a unit must be returned to the factory for service, return authorization must be obtained from our Technical Services Department.

Information about the problem

It is extremely important that information about a problem be explicit and complete. This helps us locate and repair a defect as quickly as possible.

Packing the N° 27 for shipment

The unit must be properly packaged (preferably in its original packing material) and the proper return authorization number must be marked on the outer carton for easy identification. We reserve the right to repackage any unit for shipment at the owner's expense.

LIMITED FIVE-YEAR WARRANTY

Your Mark Levinson® N° 27 Dual Monaural Power Amplifier is warranted to the original purchaser to be free from defects in material and workmanship under normal use for a period of five (5) years from the date of purchase. During the warranty period, and upon proof of purchase, any power amplifier exhibiting defects in materials and/or workmanship will be repaired or replaced, at our option, without charge for either parts or labor, at our factory. The warranty will not apply to any power amplifier that has been misused, abused or altered.

Any power amplifier not performing satisfactorily may be returned to the factory for evaluation. Return authorization must first be obtained by either calling or writing the factory prior to shipping the power amplifier. The factory will pay for return shipping charges only in the event that the power amplifier is found to be defective as above mentioned. There are other stipulations that may apply to shipping charges.

THERE IS NO OTHER EXPRESS WARRANTY ON THIS POWER AMPLIFIER. NEITHER THIS WARRANTY NOR ANY OTHER WARRANTY, EXPRESS OR IMPLIED, INCLUDING ANY IMPLIED WARRANTIES OF MERCHANTABILITY OR FITNESS, SHALL EXTEND BEYOND THE WARRANTY PERIOD. NO RESPONSIBILITY IS ASSUMED FOR ANY INCIDENTAL OR CONSEQUENTIAL DAMAGES. SOME STATES DO NOT ALLOW LIMITATIONS ON HOW LONG AN IMPLIED WARRANTY LASTS AND OTHER STATES DO NOT ALLOW THE EXCLUSION OR LIMITATION OF INCIDENTAL OR CONSEQUENTIAL DAMAGES, SO THAT THE ABOVE LIMITATION OR EXCLUSION MAY NOT APPLY TO YOU.

This warranty gives you specific legal rights, and you may also have other rights which vary from state to state.

THE UNIVERSITY OF CHICAGO

PHILOSOPHY DEPARTMENT

MADRIGAL

Madrigal Audio Laboratories, Inc.

2081 South Main Street, P.O. Box 781
Middletown, Connecticut 06457 USA

Telephone: (203) 346-0896 or 344-9300
ITT Telex: 4942158
Fax: (203) 346-1540



is a registered trademark of Madrigal Audio Laboratories, Inc.