

**HiFi ENGINE®**

For more Hi-Fi manuals and set-up information  
please visit [www.hifiengine.com](http://www.hifiengine.com)

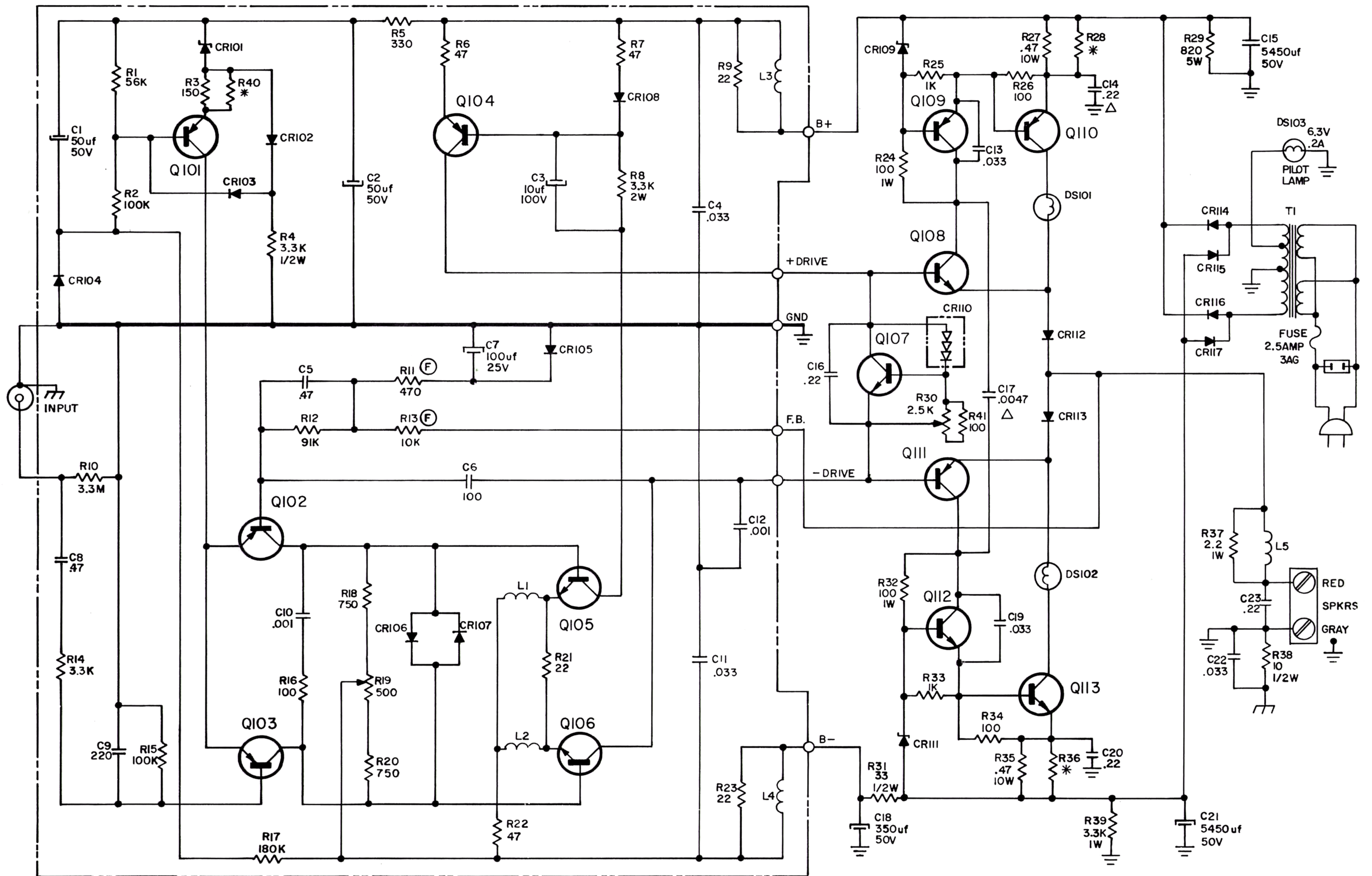



UNLESS OTHERWISE SPECIFIED: CAPACITORS IN DECIMALS ARE uf  
ALL OTHER ARE pf

(F) DENOTES PRECISION FILM RESISTORS

\* DENOTES COMPONENTS SELECTED FOR OPTIMUM CIRCUIT OPERATION.  
ALL RESISTORS ARE IN OHMS, 1/4W EXCEPT AS NOTED.

Δ DENOTES COMPONENTS THAT MAY BE OMITTED FROM UNITS.

CIRCUIT NO.	MARANTZ NO.	CIRCUIT NO.	MARANTZ NO.
CR101	DIN4736A	Q101	DTM6
CR102,8	DMR2360	Q102,3	MATCHED DTM6
CR103,5,6,7	DBTRI557	Q104	DTM9
CR104	DXIN457	Q105,6	DTM8
CR109,11	DIN4732A	Q107	DTM10
CR110	DBTRI559	Q108,12	DTM11
CR112	DMRII20R	Q109,11	DTM12
CR113	DMRII20	Q113	DTM13
CR114,116	DHC200R	Q110	DTM14
CR115,117	DHC200		

**marantz**  
WOODSIDE, NEW YORK



model fifteen

*Solid State Amplifier*