

PRICE \$2.00

HEATH COMPANY • BENTON HARBOR, MICHIGAN

# HEATHKIT® ASSEMBLY MANUAL

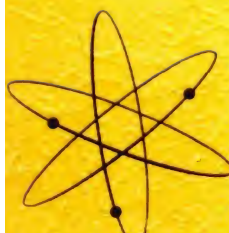
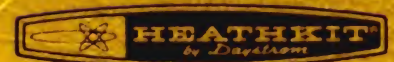

## STEREO AMPLIFIER

MODEL AA-151

# RESISTOR AND CAPACITOR COLOR CODES

## RESISTORS

The colored bands around the body of a color coded resistor represent its value in ohms. These colored bands are grouped toward one end of the resistor body. Starting with this end of the resistor, the first band represents the first digit of the resistance value; the second band represents the second digit; the third band represents the number by which the first two digits are multiplied. A fourth band of gold or silver represents a tolerance of  $\pm 5\%$  or  $\pm 10\%$  respectively. The absence of a fourth band indicates a tolerance of  $\pm 20\%$ .

The physical size of a composition resistor is related to its wattage rating. Size increases progressively as the wattage rating is increased. The diameters of 1/2 watt, 1 watt and 2 watt resistors are approximately 1/8", 1/4" and 5/16", respectively.

The color code chart and examples which follow provide the information required to identify color coded resistors.

COLOR	CODE		MULTIPLIER
	1ST DIGIT	2ND DIGIT	
BLACK	0	0	1
BROWN	1	1	10
RED	2	2	100
ORANGE	3	3	1,000
YELLOW	4	4	10,000
GREEN	5	5	100,000
BLUE	6	6	1,000,000
VIOLET	7	7	10,000,000
GRAY	8	8	100,000,000
WHITE	9	9	1,000,000,000
GOLD	-	-	.1
SILVER	-	-	.01

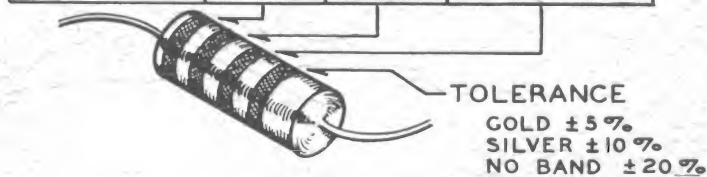

## EXAMPLES

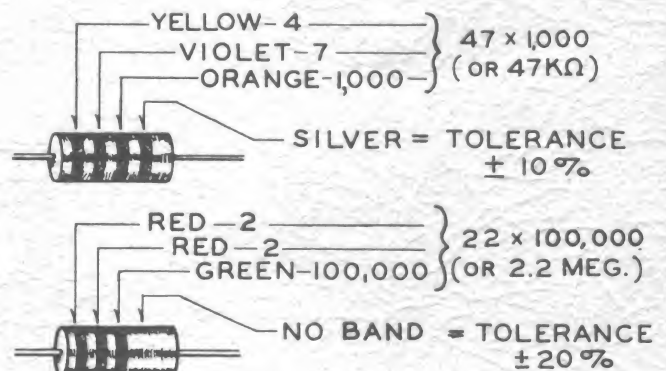

## CAPACITORS

Generally, only mica and tubular ceramic capacitors, used in modern equipment, are color coded. The color codes differ somewhat among capacitor manufacturers, however the codes

shown below apply to practically all of the mica and tubular ceramic capacitors that are in common use. These codes comply with EIA (Electronics Industries Association) Standards.

### MICA

COLOR	CODE		MULTIPLIER	TOLER. %
	1ST DIGIT	2ND DIGIT		
BLACK	0	0	1	$\pm 20$
BROWN	1	1	10	$\pm 10$
RED	2	2	100	$\pm 5$
ORANGE	3	3	1,000	$\pm 5$
YELLOW	4	4	10,000	$\pm 5$
GREEN	5	5	—	—
BLUE	6	6	—	—
VIOLET	7	7	—	—
GRAY	8	8	—	—
WHITE	9	9	—	—
GOLD	-	-	.1	$\pm 10$
SILVER	-	-	.01	$\pm 10$

### EXAMPLE

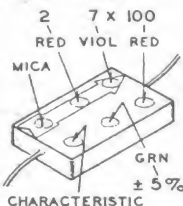

### TUBULAR CERAMIC

Place the group of rings or dots to the left and read from left to right.

COLOR	CODE		MULTIPLIER	TOLER. %
	1ST DIGIT	2ND DIGIT		
BLACK	0	0	1	$\pm 20$ OR LESS OVER 10
BROWN	1	1	10	$\pm 10$
RED	2	2	100	$\pm 5$
ORANGE	3	3	1,000	$\pm 2.5$
YELLOW	4	4	10,000	$\pm 5$
GREEN	5	5	—	$\pm 0.5$
BLUE	6	6	—	$\pm 5$
VIOLET	7	7	—	—
GRAY	8	8	—	$\pm 0.25$
WHITE	9	9	—	$\pm 1.0$

### EXAMPLE

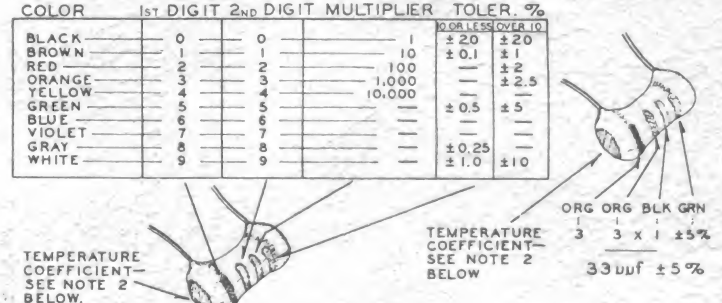

OBSERVE DIRECTION OF ARROW

WHT. OR BLK. DOT INDICATES MICA

CHARACTERISTIC—SEE NOTE 1 BELOW

(VALUE IN  $\mu\text{f}$ —SEE NOTE 3 BELOW)

TEMPERATURE COEFFICIENT—SEE NOTE 2 BELOW

TEMPERATURE COEFFICIENT—SEE NOTE 2 BELOW

(VALUE IN  $\mu\text{f}$ —SEE NOTE 3 BELOW)

## NOTES:

1. The characteristic of a mica capacitor is the temperature coefficient, drift capacitance and insulation resistance. This information is not usually needed to identify a capacitor but, if desired, it can be obtained by referring to EIA Standard, RS-153 (a Standard of Electronic Industries Association.)

2. The temperature coefficient of a capacitor is the predictable change in capacitance with temperature change and is

expressed in parts per million per degree centigrade. Refer to EIA Standard, RS-198 (a Standard of Electronic Industries Association.)

3. The farad is the basic unit of capacitance, however capacitor values are generally expressed in terms of  $\mu\text{f}$  (microfarad, .000001 farad) and  $\mu\mu\text{f}$  (micro-micro-farad, .000001  $\mu\text{f}$ ); therefore, 1,000  $\mu\mu\text{f}$  = .001  $\mu\text{f}$ , 1,000,000  $\mu\mu\text{f}$  = 1  $\mu\text{f}$ .

## USING A PLASTIC NUT STARTER

A plastic nut starter offers a convenient method of starting the most used sizes: 3/16" and 1/4" (3-48 and 6-32). When the correct end is pushed down over a nut, the pliable tool conforms to the shape of the nut and the nut is gently held while it is being picked up and started on the screw. The tool should only be used to start the nut,

6-32

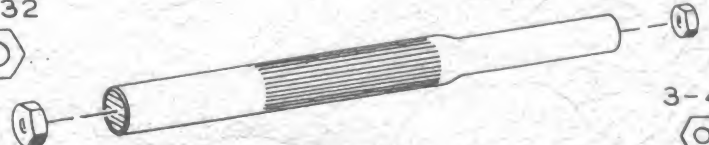











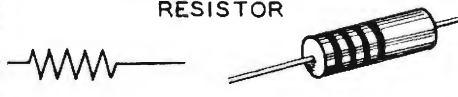

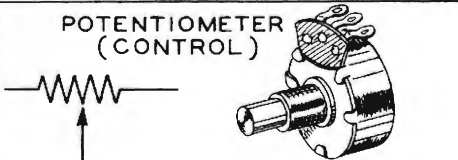
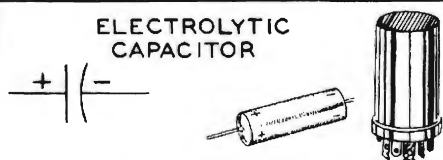

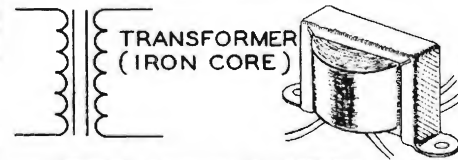
3-48

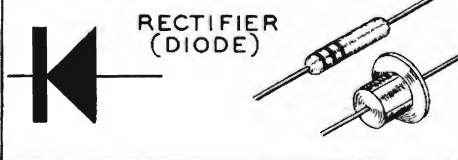
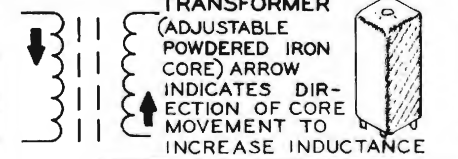
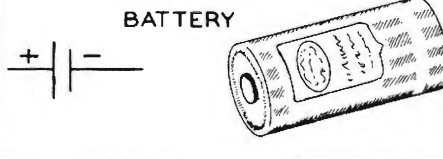
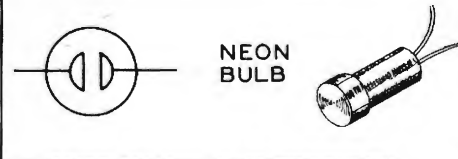
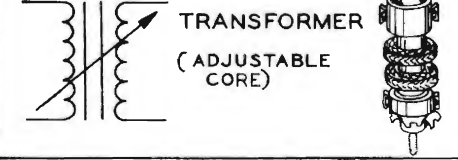

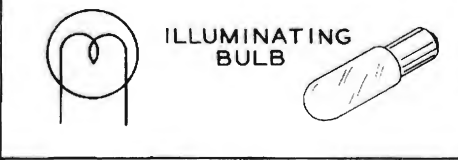
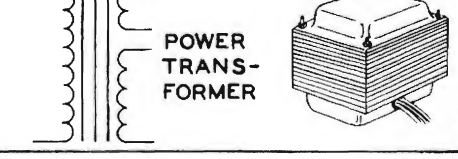
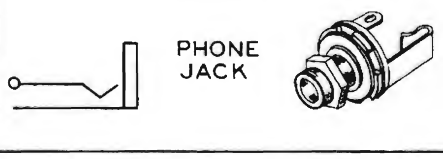
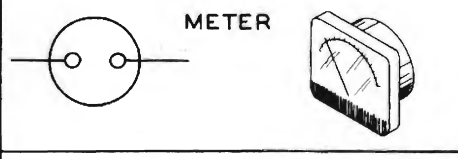
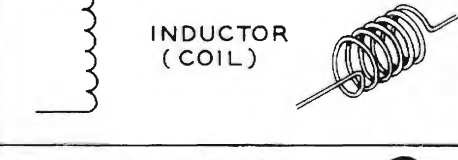
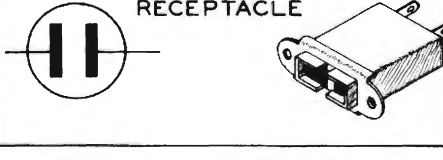
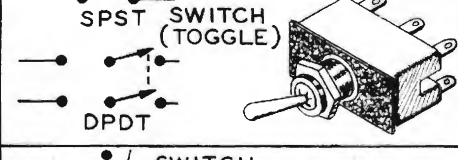
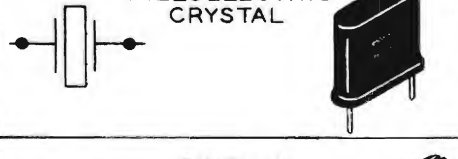
## TYPICAL COMPONENT TYPES

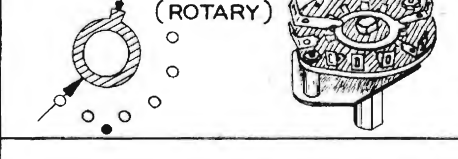
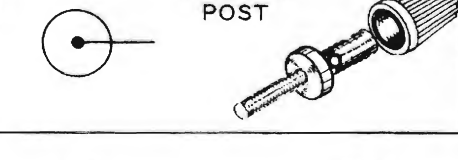
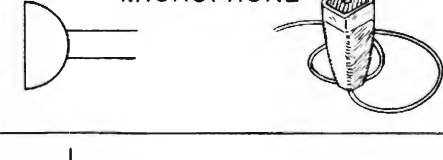
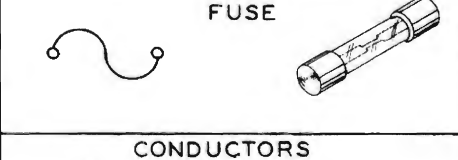
This chart is a guide to commonly used types of electronic components. The symbols and related illustrations

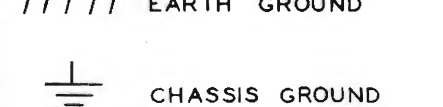
should prove helpful in identifying most parts and reading the schematic diagrams.

<p style="text-align: center;"><b>RESISTOR</b></p> 	<p style="text-align: center;"><b>CAPACITOR</b></p> 	<p style="text-align: center;"><b>TUBE</b></p> 
<p style="text-align: center;"><b>POTENTIOMETER (CONTROL)</b></p> 	<p style="text-align: center;"><b>ELECTROLYTIC CAPACITOR</b></p> 	<p style="text-align: center;"><b>TRANSISTOR</b></p> 
<p style="text-align: center;"><b>TRANSFORMER (IRON CORE)</b></p> 	<p style="text-align: center;"><b>VARIABLE CAPACITOR</b></p> 	<p style="text-align: center;"><b>RECTIFIER (DIODE)</b></p> 
<p style="text-align: center;"><b>TRANSFORMER (ADJUSTABLE POWDERED IRON CORE) ARROW INDICATES DIRECTION OF CORE MOVEMENT TO INCREASE INDUCTANCE</b></p> 	<p style="text-align: center;"><b>BATTERY</b></p> 	<p style="text-align: center;"><b>NEON BULB</b></p> 
<p style="text-align: center;"><b>TRANSFORMER (ADJUSTABLE CORE)</b></p> 	<p style="text-align: center;"><b>PHONO JACK</b></p> 	<p style="text-align: center;"><b>ILLUMINATING BULB</b></p> 
<p style="text-align: center;"><b>POWER TRANSFORMER</b></p> 	<p style="text-align: center;"><b>PHONE JACK</b></p> 	<p style="text-align: center;"><b>METER</b></p> 
<p style="text-align: center;"><b>INDUCTOR (COIL)</b></p> 	<p style="text-align: center;"><b>RECEPTACLE</b></p> 	<p style="text-align: center;"><b>SPST SWITCH (TOGGLE)</b> <b>DPDT</b></p> 
<p style="text-align: center;"><b>PIEZOELECTRIC CRYSTAL</b></p> 	<p style="text-align: center;"><b>SPEAKER</b></p> 	<p style="text-align: center;"><b>SWITCH (ROTARY)</b></p> 
<p style="text-align: center;"><b>BINDING POST</b></p> 	<p style="text-align: center;"><b>MICROPHONE</b></p> 	<p style="text-align: center;"><b>FUSE</b></p> 
<p style="text-align: center;"><b>ANTENNA</b></p> <p style="text-align: center;">GENERAL      LOOP</p> 	<p style="text-align: center;"><b>EARTH GROUND</b></p> <p style="text-align: center;"><b>CHASSIS GROUND</b></p> 	<p style="text-align: center;"><b>CONDUCTORS</b></p> <p style="text-align: center;">NOT CONNECTED      CONNECTED      SHIELDED</p> 

Assembly  
and  
Operation  
of the



STEREO  
AMPLIFIER

MODEL AA-151



HEATH COMPANY,  
BENTON HARBOR,  
MICHIGAN



TABLE OF CONTENTS

Specifications. . . . .	2
Introduction. . . . .	3
Circuit Description. . . . .	4
Schematic. . . . .	5*
Construction Notes. . . . .	5
Parts List. . . . .	6
Proper Soldering Techniques. . . . .	8
Step-By-Step Procedure. . . . .	10
Step-By-Step Assembly. . . . .	11
Test And Connections. . . . .	33
Final Assembly. . . . .	35
Installation And Operation. . . . .	35
In Case Of Difficulty. . . . .	37
Service Information. . . . .	38
Service. . . . .	38
Replacements. . . . .	39
Shipping Instructions. . . . .	40
Warranty. . . . .	40

\*Fold-out from page.

All prices are subject to change without notice. The Heath Company reserves the right to discontinue instruments and to change specifications at any time without incurring any obligation to incorporate new features in instruments previously sold.

## SPECIFICATIONS

### Power Output

Rated Power (rms): . . . . .	14 watts per channel, 28 watts monophonic.
Peak Power: . . . . .	28 watts per channel, 56 watts monophonic.
Circuit: . . . . .	Features Heath patented Ultra-Linear circuit, U.S. Patent #2, 710, 312.
Power Response: . . . . .	±1 db from 30 to 15,000 cps at 14 watt level.

### Tone Controls

Bass: . . . . .	19 db boost at 30 cps. 17 db cut at 30 cps.
Treble: . . . . .	13 db boost at 15,000 cps. 17 db cut at 15,000 cps.

### Maximum Harmonic Distortion (both channels at full output).

30 cycles: . . . . .	2%.
1 kc: . . . . .	.7%.
15 kc: . . . . .	2%.
Intermodulation Distortion (maximum): . . . . . (Using 60 cycle and 6 kc signal mixed 4:1.)	2%, both channels at full output.

### Input Sensitivity

MAG. PHONO: . . . . .	.004 volt for 14 watts output.
TUNER-AUX.: . . . . .	.2 volt for 14 watts output.
XTAL: . . . . .	.25 volt for 14 watts output.
Channel Separation: . . . . .	Better than 35 db.

### Hum And Noise

MAG. PHONO: . . . . .	55 db or better below 14 watts.
XTAL-TUNER-AUX.: . . . . .	65 db below 14 watts.

Damping Factor: . . . . . 10.

Tube Complement: . . . . .  
 2 - 6EU7  
 2 - 6AU6  
 2 - 6AN8  
 4 - EL84/6BQ5  
 1 - GZ34/5AR4

Controls And Switches: . . . . .	SOURCE Selector (MAG. PHONO, XTAL PHONO, TUNER, AUX.) VOLUME (dual-concentric with clutch). BASS (dual-tandem). TREBLE (dual-tandem). MODE Selector (AMP LEFT, AMP RIGHT, MONO LEFT SOURCE, MONO RIGHT SOURCE, STEREO, and STEREO REV.) POWER (ON-OFF). SPKR. PHASE (NORM.-REV.) FILAMENT BALANCE (LEFT CHANNEL and RIGHT CHANNEL).
AC Receptacles: . . . . .	1 - NORMAL (unswitched), 3 amps maximum. 1 - SWITCHED, 1 amp maximum.
Power Supply: . . . . .	Transformer-operated full-wave rectifier.
Power Requirements: . . . . .	117 volts AC, 50/60 cps, at 130 watts.
Dimensions	
Overall: . . . . .	5-1/4" high x 15" wide x 11" deep.
Clearance required for rear apron connections: . . . . .	1-1/4".
Net Weight: . . . . .	25 lbs.
Shipping Weight: . . . . .	28 lbs.

Features patented Heath Ultra-Linear® circuit  
U. S. Patent #2,710,312

## INTRODUCTION

Your HEATHKIT Model AA-151 Stereo Amplifier is, effectively, two high fidelity amplifiers, two preamplifiers and a power supply, all contained in a single, attractively styled vinyl-clad cabinet. Quality, versatility, styling, and economy are the keynotes of the AA-151 design.

The use of two independent power amplifiers and preamplifiers as a single unit provides excellent

performance versatility, which could not be duplicated using separate amplifiers and preamplifiers occupying the same amount of space as the AA-151. Either eight monophonic or four stereo signal sources can be connected to the input jacks of the AA-151. Each input source can then be selected individually with the SOURCE selector switch. The output level of the power amplifiers may be set separately or simultaneously with the clutched VOLUME control.

## CIRCUIT DESCRIPTION

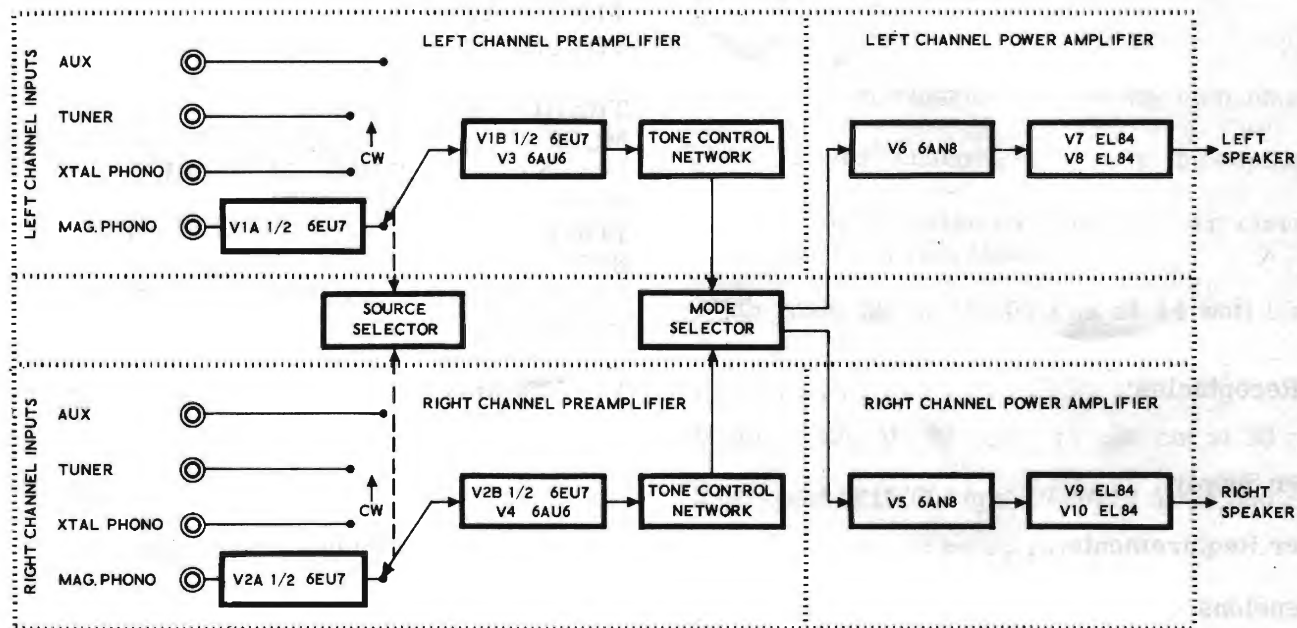

## BLOCK DIAGRAM

The Model AA-151 Stereo Amplifier has three basic sections; a common power supply, the left channel preamplifier and amplifier, and the right channel preamplifier and amplifier.

The left and right channel preamplifier and amplifier circuits are identical, therefore, only the left channel and power supply circuits will be discussed. For the purpose of this description, assume that the SOURCE switch is in the MAG. PHONO position and that the MODE selector switch is in the LEFT AMP position. We suggest that you frequently refer to the Schematic and Block Diagrams.

The audio signal presented to the MAG. PHONO input is applied directly to the grid of tube V1A. V1A is a high-gain, low-noise preamplifier stage. The amplified signal is coupled from the plate of V1A through capacitor C5 to the grid of V1B. Resistors R9 and R10, along with capacitors C3, C4 and C6, provide RIAA equalization for magnetic phono cartridges. V1B is also a high-gain preamplifier. The amplified signal from its plate is coupled by capacitor C8 and the VOLUME control to the grid of V3.

V3 further increases the amplitude of the signal. The amplified signal from V3 is fed through capacitor C11 to the packaged electronic tone control network. This network, consisting of several resistors and capacitors, encapsulated in an insulating material, operate in conjunction with R20 and R23 to perform the BASS and TREBLE control functions. The output signal of the tone control network is applied through the MODE switch to the grid of V6A.

The signal is again amplified by V6A and is applied to the grid of V6B, the phase inverter. V6B does not amplify the signal, but applies the signal in proper phase, to each tube (V7 and V8) in the push-pull amplifier output stage.

The signal from the push-pull output stage is coupled through audio output transformer T1 to the left channel speaker system.

The power supply uses a 5AR4 tube as a full-wave rectifier. The filter network, consisting of capacitors C25, C24, C23, and C22, and resistors R36, R35, and R34, removes the 120 cycle ripple from the B+ voltage.

## CONSTRUCTION NOTES

This manual is supplied to assist you in every way to complete your kit with the least possible chance for error. The arrangement shown is the result of extensive experimentation and trial. If followed carefully, the result will be a stable instrument, operating at a high degree of dependability. We suggest that you retain the manual in your files for future reference, both in the use of the instrument and for its maintenance.

**UNPACK THE KIT CAREFULLY AND CHECK EACH PART AGAINST THE PARTS LIST.** In so doing, you will become acquainted with the parts. Refer to the charts and other information on the inside covers of the manual to help you identify the components. If some shortage or parts damage is found in checking the Parts List, please read the Replacement section and supply the information called for therein. Include all inspection slips in your letter to us.

Resistors generally have a tolerance rating of 10% unless otherwise stated in the Parts List. Tolerances on capacitors are generally even greater. Limits of +100% and -20% are common for electrolytic capacitors.

We suggest that you do the following before work is started:

1. Lay out all parts so that they are readily available.
2. Provide yourself with good quality tools. Basic tool requirements consist of a screwdriver with a 1/4" blade; a small screwdriver with a 1/8" blade; long-nose pliers; wire cutters, preferably separate diagonal cutters; a pen knife or a tool for stripping insulation from wires; a soldering iron (or gun) and rosin core solder. A set of nut drivers and a nut starter, while not necessary, will aid extensively in construction of the kit.

Most kit builders find it helpful to separate the various parts into convenient categories. Muffin tins or molded egg cartons make convenient trays for small parts. Resistors and capacitors may be placed with their lead ends inserted in the edge of a piece of corrugated cardboard until they are needed. Values can be written on the cardboard next to each component. The illustration shows one method that may be used.

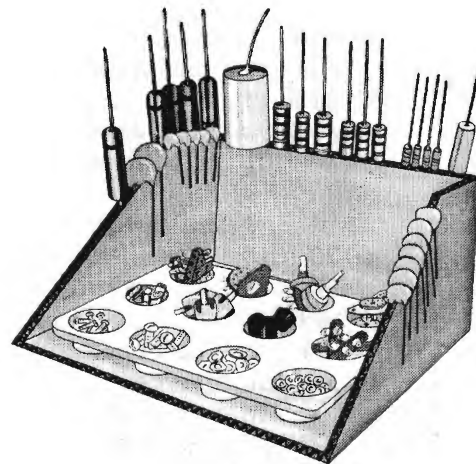



## PARTS LIST

<u>PART No.</u>	<u>PARTS Per Kit</u>	<u>DESCRIPTION</u>	<u>PART No.</u>	<u>PARTS Per Kit</u>	<u>DESCRIPTION</u>
<u>Resistors</u>			<u>Capacitors (cont'd.)</u>		
1-9	4	1000 $\Omega$ 1/2 watt (brown-black-red)	25-42	1	30-30 $\mu$ fd at 350 volts twist prong electrolytic
1-13	4	2700 $\Omega$ 1/2 watt (red-violet-red)	25-55	2	50 $\mu$ fd at 10 volts miniature electrolytic
1-22	5	22 K $\Omega$ 1/2 watt (red-red-orange)	25-85	1	50 $\mu$ fd at 25 volts tubular electrolytic
1-23	2	27 K $\Omega$ 1/2 watt (red-violet-orange)	25-101	1	60-25 $\mu$ fd at 500-450 volts twist-prong electrolytic
1-24	5	33 K $\Omega$ 1/2 watt (orange-orange-orange)	<u>Controls-Switches</u>		
1-88	4	36 K $\Omega$ 1/2 watt (orange-blue-orange)	10-61	2	200 $\Omega$ tab-mount control
1-25	2	47 K $\Omega$ 1/2 watt (yellow-violet-orange)	12-34	1	1 megohm dual-concentric control
1-26	5	100 K $\Omega$ 1/2 watt (brown-black-yellow)	12-35	2	1 megohm dual-tandem con- trol
1-27	3	150 K $\Omega$ 1/2 watt (brown-green-yellow)	60-2	1	DPDT slide switch
1-29	4	220 K $\Omega$ 1/2 watt (red-red-yellow)	63-249	1	AC switch
1-30	2	270 K $\Omega$ 1/2 watt (red-violet-yellow)	63-258	1	4-position, single-section rotary switch
1-33	10	470 K $\Omega$ 1/2 watt (yellow-violet-yellow)	63-259	1	6-position, single-section rotary switch
1-34	2	680 K $\Omega$ 1/2 watt (blue-gray-yellow)	<u>Transformers</u>		
1-35	2	1 megohm 1/2 watt (brown-black-green)	51-29	2	Audio output
1-37	2	2.2 megohm 1/2 watt (red-red-green)	54-93	1	Power
4-2	2	100 K $\Omega$ 1/2 watt LOW-NOISE (brown-black-yellow)	<u>Terminal Strips-Sockets</u>		
1A-2	1	1000 $\Omega$ 1 watt (brown-black-red)	431-1	6	Dual 1-lug terminal strip
1B-2	1	4700 $\Omega$ 2 watt (yellow-violet-red)	431-2	2	2-lug terminal strip
3G-9	1	100 $\Omega$ 7 watt wire-wound	431-3	3	3-lug terminal strip
<u>Capacitors</u>			431-5	6	4-lug terminal strip
21-3	2	10 $\mu$ fd disc ceramic	431-13	1	4-lug screw type terminal strip
21-7	6	33 $\mu$ fd disc ceramic	431-17	1	5-lug screw type terminal strip
21-85	2	56 $\mu$ fd disc ceramic	431-27	3	3-lug terminal strip
21-39	2	.0035 $\mu$ fd disc ceramic	434-15	2	7-pin wafer tube socket
21-42	1	.01 $\mu$ fd disc ceramic 1.6 kv	434-16	4	9-pin wafer tube socket
21-47	2	.01 $\mu$ fd disc ceramic	434-20	2	AC socket
21-82	1	.02 $\mu$ fd disc ceramic	434-58	1	Octal tube socket
23-50	2	.022 $\mu$ fd tubular	434-68	4	9-pin molded tube socket
23-52	2	.047 $\mu$ fd tubular	434-76	2	Triple phono socket
23-61	4	.05 $\mu$ fd tubular	434-82	1	Double phono socket
23-28	8	.1 $\mu$ fd tubular	<u>Tubes-Lamp-Fuses</u>		
			411-11	2	6AU6 tube
			411-68	2	6AN8 tube
			411-108	4	EL84 tube

<u>PART No.</u>	<u>PARTS Per Kit</u>	<u>DESCRIPTION</u>
-----------------	----------------------	--------------------

 Tubes-Lamps-Fuse (cont'd.)

411-136	1	GZ34/5AR4
411-143	2	6EU7 tube
412-13	1	Red neon pilot lamp
421-3	1	2-amp slow-blow fuse

 Hardware

250-8	16	#6 x 3/8" sheet metal screw
250-10	4	6-32 x 1/2" truss head machine screw
250-49	20	3-48 x 1/4" screw
250-56	40	6-32 x 1/4" screw
250-89	22	6-32 x 3/8" screw
250-106	2	6-32 x 3/8" self-tapping screw
252-1	20	3-48 nut
252-3	64	6-32 nut
252-4	12	8-32 nut
252-7	6	Control nut
252-32	1	Push-on speednut
254-1	72	#6 lockwasher
254-2	12	#8 lockwasher
254-4	10	Control lockwasher
254-7	20	#3 lockwasher
255-1	2	1/8" spacer
259-11	1	Spade lug

 Wire-Knobs

89-1	1	Line cord
340-1	1	Length bus wire
341-1	1	Length heavy black wire
343-6	1	Length shielded audio cable
344-1	2	Length hookup wire (light and dark color)
346-1	1	Length sleeving
347-9	1	Length 3-conductor shielded cable
462-117	1	Small black knob 3/4" x 5/8"
462-118	1	Clear plastic knob 1-13/16" x 13/32"

<u>PART No.</u>	<u>PARTS Per Kit</u>	<u>DESCRIPTION</u>
-----------------	----------------------	--------------------

 Wire-Knobs (cont'd.)

462-119	1	Small black knob 3/4" x 5/8" for .187 diameter shaft
462-124	4	Black and clear plastic cascaded knob

 Sheet Metal

90-M166	1	Cabinet
200-M296F469-470	1	Chassis
203-M234F467	1	Control panel
203-M235F468-498	1	Front panel
203-M236	1	Subpanel
204-M366	1	Left front panel support bracket
204-M367	1	Right front panel support bracket
205-M296	1	Bottom plate
206-M176F471	1	Center shield
210-14	1	Front bezel

 Miscellaneous

75-20	1	Insulated plate for double phono socket
75-24	1	Line cord strain relief
75-41	2	Insulator for triple phono socket
84-23	2	Packaged Electronic Circuit (P.E.C.) tone control network
206-3	2	Tube shield
206-55	2	Tube base shield
261-17	4	Plastic foot
391-11	1	Nameplate
423-1	1	Fuse holder
481-1	1	Metal capacitor mounting wafer
481-4	1	Fiber capacitor mounting wafer
331-6		Solder
595-421	1	Manual

## PROPER SOLDERING TECHNIQUES

Only a small percentage of HEATHKIT equipment purchasers find it necessary to return an instrument for factory service. Of these instruments, by far the largest portion of malfunctions are due to poor or improper soldering.

If terminals are bright and clean and free of wax, frayed insulation and other foreign substances, no difficulty will be experienced in soldering. Correctly soldered connections are essential if the performance engineered into a kit is to be fully realized. If you are a beginner with no experience in soldering, a half hour's practice with some odd lengths of wire may be a worthwhile investment.

For most wiring, a 30 to 100 watt iron or its equivalent in a soldering gun is very satisfactory. A lower wattage iron than this may not heat the connection enough to flow the solder smoothly over the joint. Keep the iron tip clean and bright by wiping it from time to time with a cloth.

### CHASSIS WIRING AND SOLDERING

1. Unless otherwise indicated, all wire used is the type with colored insulation (hookup wire); the size of the conductor is the same for all colors of hookup wires furnished with this kit. In preparing a length of hookup wire, 1/4" of insulation should be removed from each end unless directed otherwise in the construction step.
2. To avoid breaking internal connections when stripping insulation from the leads of transformers or similar components, care should be taken not to pull directly on the lead. Instead, hold the lead with pliers while it is being stripped.
3. Leads on resistors, capacitors and similar components are generally much longer than they need to be to make the required connections. In these cases, the leads should be cut to proper length before the part is added to the chassis. In general, the leads should be just long enough to reach their terminating points.
4. Wherever there is a possibility of bare leads shorting to other parts or to the chassis, the leads should be covered with insulating sleeving. Where the use of sleeving is specifically intended, the phrase "use sleeving" is included in the associated construction step. In any case where there is the possibility of an unintentional short circuit, sleeving should be used. Extra sleeving is provided for this purpose.
5. Crimp or bend the lead (or leads) around the terminal to form a good joint without relying on solder for physical strength. If the wire is too large to allow bending or if the step states that the wire is not to be crimped, position the wire so that a good solder connection can still be made.
6. Position the work, if possible, so that gravity will help to keep the solder where you want it.
7. Place a flat side of the soldering iron tip against the joint to be soldered until it is heated sufficiently to melt the solder.
8. Then place the solder against the heated terminal and it will immediately flow over the joint; use only enough solder to thoroughly wet the junction. It is usually not necessary to fill the entire hole in the terminal with solder.
9. Remove the solder and then the iron from the completed junction. Use care not to move the leads until the solder is solidified.

A poor or cold solder joint will usually look crystalline and have a grainy texture, or the solder will stand up in a blob and will not have adhered to the joint. Such joints should be reheated until the solder flows smoothly over the entire junction. In some cases, it may be necessary to add a little more solder to achieve a smooth bright appearance.

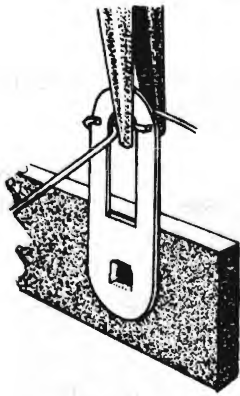

CRIMP WIRES

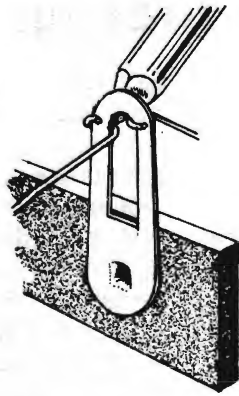

HEAT CONNECTION

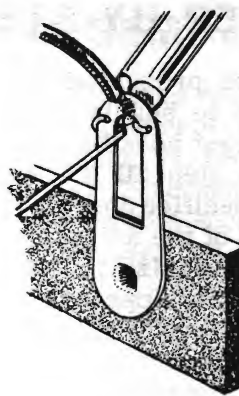

APPLY SOLDER

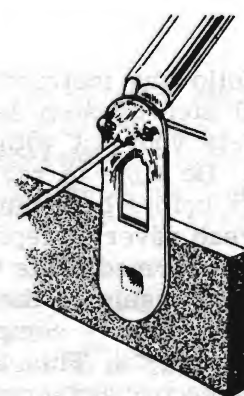

ALLOW SOLDER TO FLOW

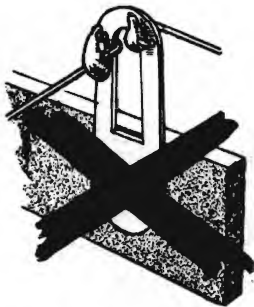

COLD SOLDER JOINT CONNECTION INSUFFICIENTLY HEATED

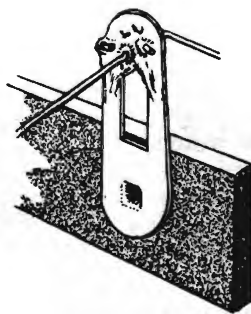

PROPER SOLDER CONNECTION

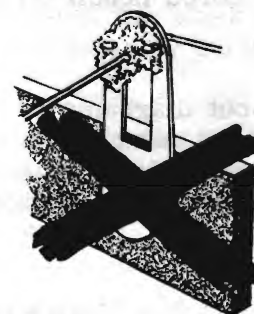

COLD SOLDER JOINT CONNECTION MOVED WHILE COOLING

ROSIN CORE SOLDER HAS BEEN SUPPLIED WITH THIS KIT. THIS TYPE OF SOLDER MUST BE USED FOR ALL SOLDERING IN THIS KIT. ALL GUARANTEES ARE VOIDED AND WE WILL NOT REPAIR OR SERVICE EQUIPMENT IN WHICH ACID CORE SOLDER OR PASTE FLUXES HAVE BEEN USED. IF ADDITIONAL SOLDER IS NEEDED, BE SURE TO PURCHASE ROSIN CORE (60:40 or 50:50 TIN-LEAD CONTENT) RADIO TYPE SOLDER.

## STEP-BY-STEP PROCEDURE

The following instructions are presented in a logical step-by-step sequence to enable you to complete your kit with the least possible confusion. Be sure to read each step all the way through before beginning the specified operation. Also read several steps ahead of the actual step being performed. This will familiarize you with the relationship of the subsequent operations. When the step is completed, check it off in the space provided. This is particularly important as it may prevent errors or omissions, especially if your work is interrupted. Some kit builders have also found it helpful to mark each lead in colored pencil on the Pictorial as it is added.

The fold-out diagrams in this manual may be removed and attached to the wall above your working area; but, because they are an integral part of the instructions, they should be returned to the manual after the kit is completed.

In general, the illustrations in this manual correspond to the actual configuration of the kit; however, in some instances the illustra-

tions may be slightly distorted to facilitate clearly showing all of the parts.

The abbreviation "NS" indicates that a connection should not be soldered yet as other wires will be added. When the last wire is installed, the terminal should be soldered and the abbreviation "S" is used to indicate this. Note that a number will appear after each solder instruction. This number indicates the number of leads that are supposed to be connected to the terminal in point before it is soldered. For example, if the instruction reads, "Connect a lead to lug 1 (S-2)," it will be understood that there will be two leads connected to the terminal at the time it is soldered. (In cases where a lead passes through a terminal or lug and then connects to another point, it will count as two leads, one entering and one leaving the terminal.)

The steps directing the installation of resistors include color codes to help identify the parts. Also, if a part is identified by a letter-number designation on the Schematic, its designation will appear in the construction step which directs its installation.

## STEP-BY-STEP ASSEMBLY

Refer to Pictorial 1 (fold-out from Page 15) for the following steps.

NOTE: The phrase "#6 hardware" means 6-32 x 1/4" screws, #6 lockwashers, and 6-32 nuts.

Position the chassis as shown in Pictorial 1.

- ( ) Referring to Detail 1A, mount the octal tube socket at location V11. Use #6 hardware. Orient the keyway of the tube socket as shown by the arrow in Pictorial 1.

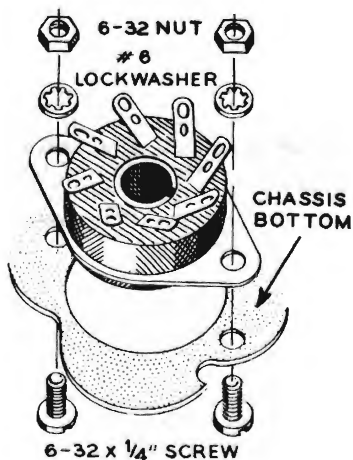

Detail 1A

NOTE: When mounting wafer tube sockets, be sure to mount each socket from the bottom of the chassis. If, by mistake, the sockets are mounted so the lugs pass through the chassis, they will short to the chassis where they pass through the mounting hole.

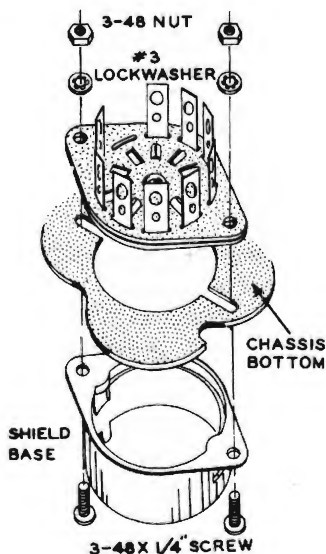

Detail 1B

- ( ) Referring to Detail 1B, mount 9-pin wafer tube socket and shield bases at locations V1 and V2. Use 3-48 screws, #3 lockwashers, and 3-48 nuts. Orient the blank space of each tube socket as shown by the arrows in Pictorial 1.
- ( ) Mount 9-pin wafer tube sockets at locations V5 and V6. Use 3-48 screws, #3 lockwashers and 3-48 nuts. Be sure to orient the blank space as shown by the arrow in Pictorial 1.
- ( ) Mount 7-pin wafer tube sockets at locations V3 and V4. Use 3-48 screws, #3 lockwashers, and 3-48 nuts. Orient the blank space of each tube socket as shown by the arrows in Pictorial 1.
- ( ) Referring to Detail 1C, mount 9-pin molded tube sockets at locations V7, V8, V9, and V10. Use 3-48 screws, #3 lockwashers and 3-48 nuts. Be sure to orient the blank spaces as shown by the arrows in Pictorial 1.

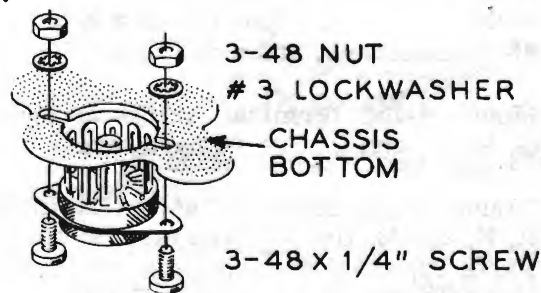

Detail 1C

- ( ) R69. Mount a 200  $\Omega$  twist-tab control (#10-61) at location J. Secure the control by twisting each mounting tab 1/4 turn with long-nose pliers. Refer to Detail 1D. Orient the lugs as shown in Pictorial 1.

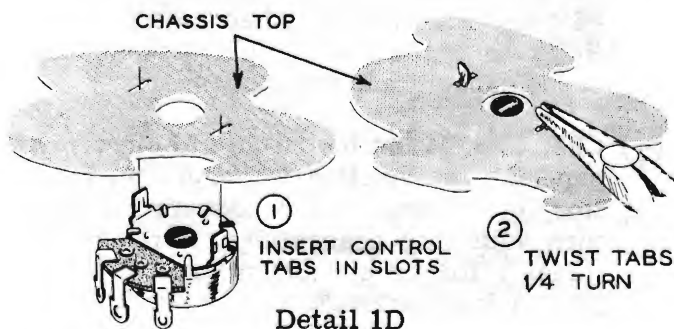

Detail 1D

- ( ) R70. Similarly, install a 200  $\Omega$  twist-tab control (#10-61) at location K. Orient the lugs as shown in Pictorial 1.

- ( ) Referring to Detail 1E, mount a dual 1-lug terminal strip at location A. Use #6 hardware.

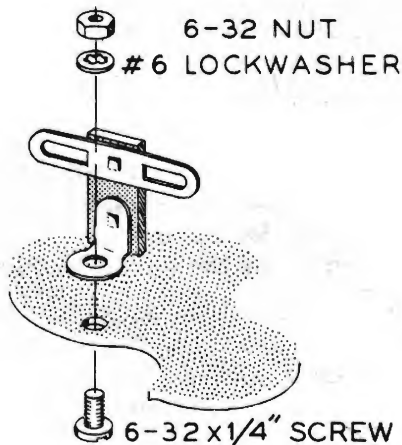

Detail 1E

- ( ) Similarly mount dual 1-lug terminal strips at locations B, C, S, and T. Use #6 hardware.
- ( ) Mount a dual 1-lug and a 4-lug terminal strip at M and L. Use a 6-32 x 3/8" screw, #6 lockwashers, and a 6-32 nut.
- ( ) Mount 4-lug terminal strips at locations G, P, W, and X. Use #6 hardware.
- ( ) Mount 3-lug terminal strips at locations H, N, and Q. Use #6 hardware. Refer to the Parts Pictorial and Pictorial 1 for identification of the proper terminal strips.
- ( ) Referring to Detail 1F, mount the fiber electrolytic capacitor mounting wafer at location E, and mount a 3-lug terminal strip at location F on one of the mounting screws. Use a 6-32 x 3/8" screw, #6 lockwashers and a 6-32 nut for the double mounting. Use #6 hardware for the other mounting hole. Refer to Pictorial 1 for proper orientation of the capacitor lug markings.
- ( ) C22, C23. Mount the 30-30  $\mu$ fd electrolytic capacitor at location E. Secure the capacitor by twisting each mounting lug 1/4 turn with long-nose pliers. Refer to Pictorial 1 for proper orientation of the capacitor lug markings.

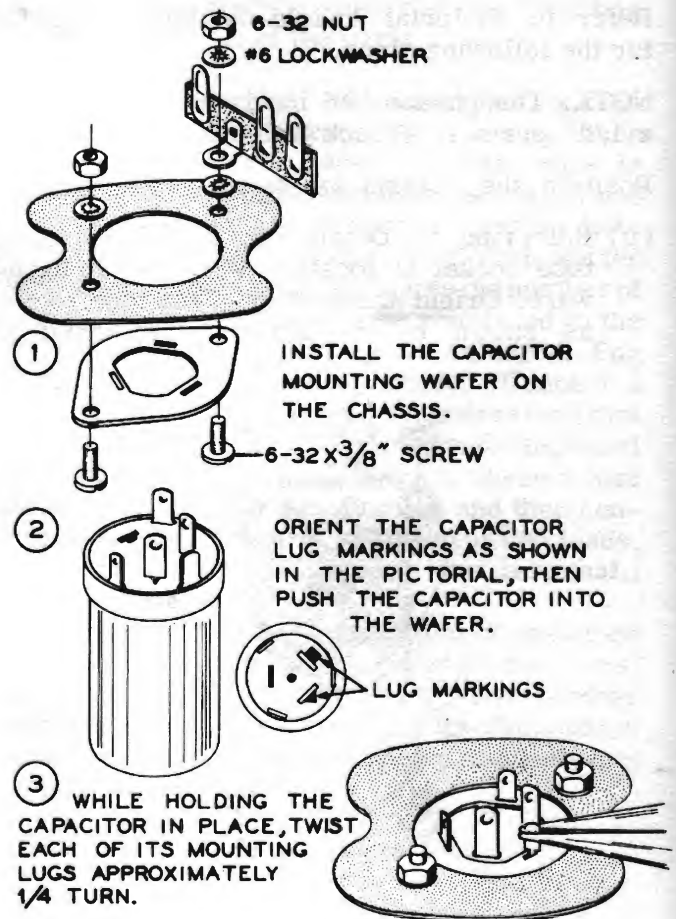

Detail 1F

- ( ) Mount 2-lug terminal strips at locations R and U. Use #6 hardware.
- ( ) Similarly, mount the metal electrolytic capacitor mounting wafer at location D. Use #6 hardware.
- ( ) C24, C23. Mount the 60-25  $\mu$ fd electrolytic capacitor (#25-101) at location D. Secure the capacitor by twisting each mounting lug 1/4 turn with long-nose pliers. Refer to Pictorial 1 for proper orientation of the capacitor lug markings.

Cut the leads of the power transformer (#54-93) to the following lengths (measured from the exit of the transformer).

<u>COLOR</u>	<u>LENGTH</u>
<input type="checkbox"/> Green	3-1/2"
<input type="checkbox"/> Green	3-1/4"
<input type="checkbox"/> Blue	3"
<input type="checkbox"/> Blue	2-1/2"
<input type="checkbox"/> Red-yellow	2"
<input type="checkbox"/> Long black	3"
<input type="checkbox"/> Black	
<input type="checkbox"/> Red	
<input type="checkbox"/> Red	
<input type="checkbox"/> Yellow	
<input type="checkbox"/> Yellow	

Do not cut these leads as they are of proper length.

Strip 1/4" of insulation from the end of each lead and "tin." (Tin means to melt a small amount of solder on the exposed wire ends.)

Cut the leads of either output transformer (#51-29) as follows:

<u>COLOR</u>	<u>LENGTH</u>
<input type="checkbox"/> Brown	3-1/2"
<input type="checkbox"/> Orange	3"
<input type="checkbox"/> Yellow	3"
<input type="checkbox"/> Black	2"
<input type="checkbox"/> Red	3"
<input type="checkbox"/> Blue	2-1/2"
<input type="checkbox"/> Green	2-1/2"

Blue-yellow 2-1/2"

Green-yellow 2"

Strip 1/4" of insulation from the end of each lead and tin.

Cut the leads of the remaining output transformer (#51-29) as follows:

<u>COLOR</u>	<u>LENGTH</u>
<input type="checkbox"/> Yellow	3-1/2"
<input type="checkbox"/> Orange	3"
<input type="checkbox"/> Brown	2-3/4"
<input type="checkbox"/> Black	1-3/4"
<input type="checkbox"/> Green-yellow	3-3/4"
<input type="checkbox"/> Blue-yellow	3-1/2"
<input type="checkbox"/> Blue	3"
<input type="checkbox"/> Green	2-1/2"
<input type="checkbox"/> Red	Do not cut

Strip 1/4" of insulation from the end of each lead and tin.

Mark this transformer as T1 so that it can be identified in the following steps.

T1. Mount output transformer T1 as shown in Pictorial 1. The black, brown, orange, and yellow leads should be toward the rear apron of the chassis. Secure the transformer with #8 lockwashers and 8-32 nuts.

T2. Similarly, mount the other output transformer at T2. Again place the transformer with its black, brown, orange, and yellow leads toward the rear apron of the chassis. Use #8 lockwashers and 8-32 nuts to secure the transformer.

T3. Mount the power transformer on the chassis at T3 as shown. Use #8 lockwashers and 8-32 nuts to secure the transformer.



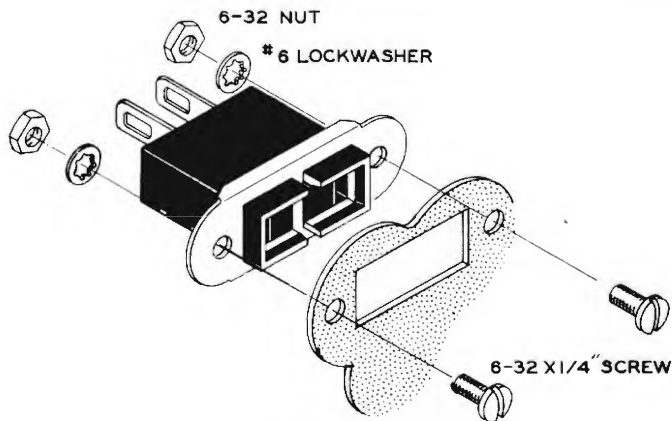

Detail 1G

- ( ) Referring to Detail 1G, mount an AC socket at location BA. Use #6 hardware. Bend the two lugs of the socket at 90 degree angles as shown in Pictorial 1.
- ( ) Similarly, mount the remaining AC socket at location BB. Bend the two lugs at 90 degree angles as shown in Pictorial 1.

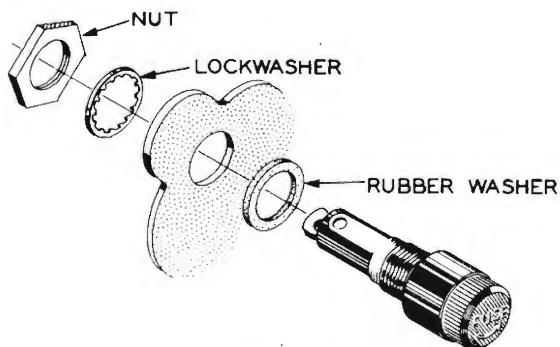

Detail 1H

- ( ) Referring to Detail 1H, mount the fuse holder at location BC. Use the hardware supplied with the fuse holder. Bend lug 1 away from the fuse holder body and orient the fuse holder as shown in Pictorial 1.
- ( ) Referring to Detail 1J, mount the 5-lug screw type terminal strip at location BD. Use #6 hardware to secure one end of this terminal strip. At the other end a 6-32 x 1/4" screw should be placed through the terminal strip, the rear apron of the chassis, and then into slide switch BE.

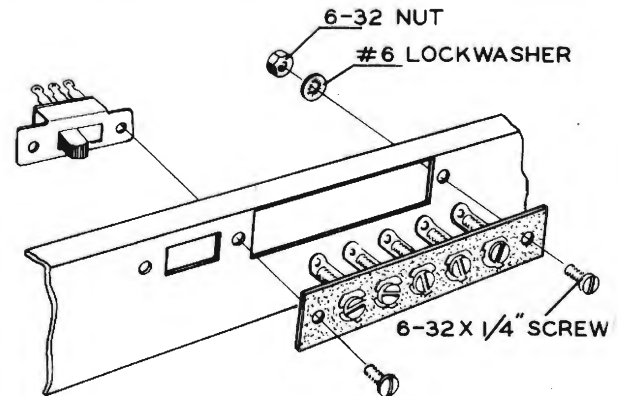

Detail 1J

- ( ) Similarly, mount the 4-lug screw type terminal at location BF. Again #6 hardware should be used to secure one end of the terminal strip. A 6-32 x 1/4" screw should be placed through the other end of the terminal strip, through the rear apron, and then into slide switch BE.

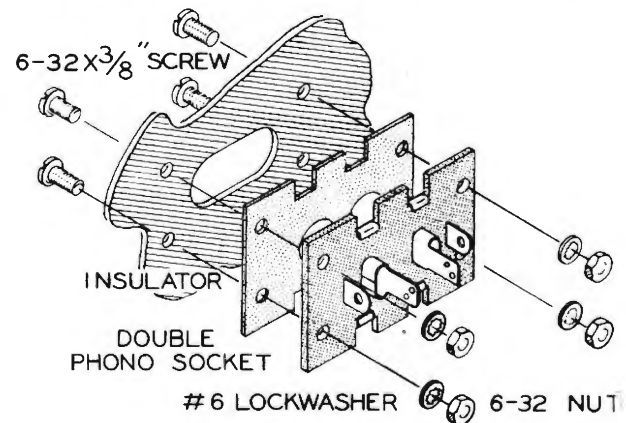

Detail 1K

- ( ) Referring to Detail 1K, mount a double phono socket and insulator at location BG. Use 6-32 x 3/8" screws, #6 lockwashers, and 6-32 nuts.
- ( ) Install a #6 sheet metal screw in each side of the chassis, near the front edge, as shown in Pictorial 1.
- ( ) Locate the subpanel and, referring to Detail 1L, mount the AC switch (#63-249) and the subpanel at location FF. Use a control nut. Do not tighten yet.

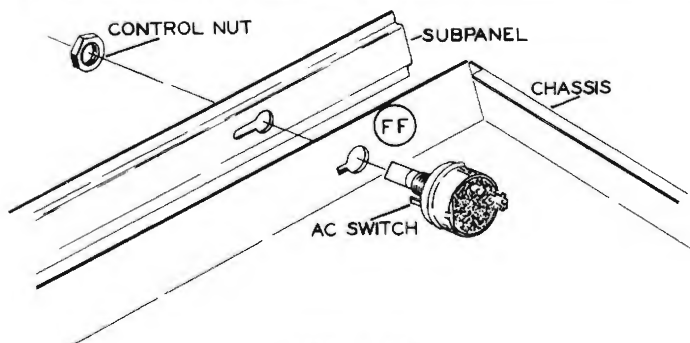

Detail 1L

- ( ) Secure the other end of the subpanel to the chassis with a 6-32 x 3/8" screw, #6 lockwasher, and a 6-32 nut. Now tighten the control nut on FF.

NOTE: In cases where a lead passes through a terminal or lug and then connects to another point, it will count as two leads, one entering and one leaving the terminal.

- ( ) Locate the heavy bus wire, straighten it to remove the kinks, and pass one end through lug 4 of terminal strip P (NS), through the center hole in dual 1-lug terminal strip S (NS), and through the center hole in dual 1-lug terminal strip T (S-1). Now solder the connection at terminal strip S (S-2). Cut off excess lengths at terminal strip P.

Refer to Pictorial 2 (on Page 17) for the following steps.

- ( ) Turn the chassis over and mount a 3-lug terminal strip at location Y. Use #6 hardware.
- ( ) Referring to Detail 2A, mount the front panel to the main chassis. Secure the front panel with #6 hardware.

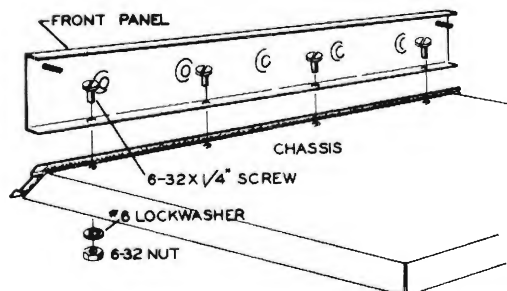

Detail 2A

- ( ) Referring to Detail 2B, mount the MODE selector switch (#63-259) at location FA. Use two control lockwashers and a control nut. Turn the switch shaft fully clockwise and position the lugs as shown in Pictorial 2. Use a knob for proper indexing.

- ( ) R23, R59. Mount a dual-tandem control (#12-35) at location FB. Use two control lockwashers, and a control nut. Orient the lugs as shown in Pictorial 2.
- ( ) R20, R55. Similarly, mount another dual-tandem control (#12-35) at location FC. Orient the lugs as shown in Pictorial 2. Use two control lockwashers, and a control nut.

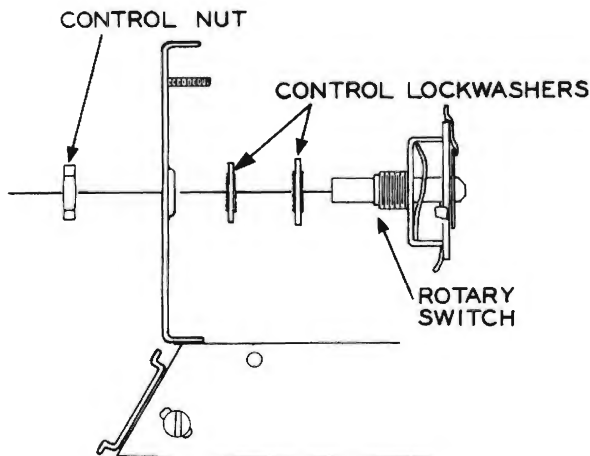

Detail 2B

- ( ) R15, R51. Temporarily mount a dual-concentric control (#12-34) at location FD. Orient the control lugs as shown in Pictorial 2. Use two control lockwashers and a control nut.
- ( ) Mount the Input Selector switch (#63-258) at location FE. Use two control lockwashers and a control nut. The flat of the shaft should be oriented so that it is exactly opposite the MAG. PHONO position printed on the front panel, when turned fully counterclockwise. Use a knob for proper indexing.

NOTE: The purpose of using twisted pairs of hookup wire is to provide shielding for signal carrying leads and cancellation of hum in the filament and AC leads. Best results will be obtained in the following steps if the wires are twisted approximately three complete turns per inch. See Detail 2C. The wires may be twisted by hand or with a drill as shown in Detail 2D on Page 16. If a drill is used be careful not to twist the wires too tightly.

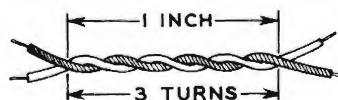

Detail 2C

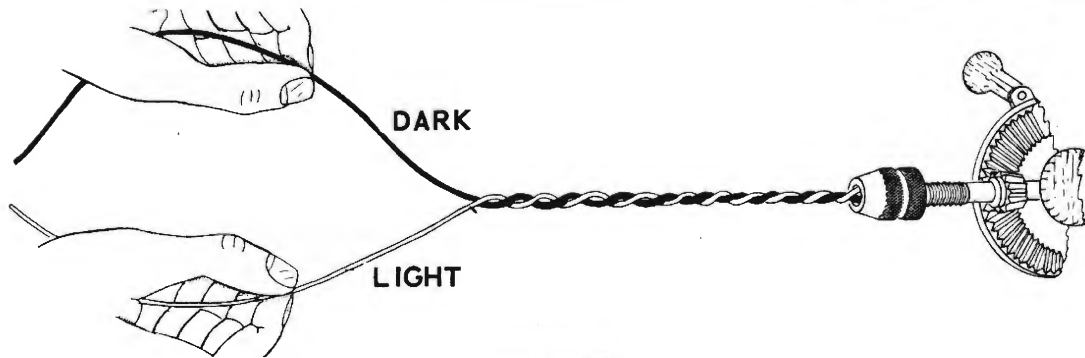

Detail 2D

- ( ) Take 20 feet of the light hookup wire and 20 feet of the dark hookup wire. Referring to Details 2C and 2D twist these two wires together.

NOTE: When making a connection with hookup wire, 1/4" of insulation should be removed, unless directed otherwise in the step.

- ( ) At one end of a 4-1/2" twisted pair, connect the light wire to lug 7 (NS) and the dark wire to double-lug 1 (NS) of switch FA.
- ( ) At the other end of this twisted pair, connect the light colored wire to lug 2 of control FB (NS). The dark wire serves as a shield and is not connected at this end.
- ( ) At one end of another 4-1/2" twisted pair, connect the light wire to lug 6 (NS), and the dark wire to lug 1 (NS) of FA.
- ( ) At the other end of this twisted pair, connect the light wire to lug 5 of control FB (NS). The dark wire is not used at this end.
- ( ) At one end of a 7" twisted pair, connect the light wire to lug 3 (S-1) and the dark wire to lug 1 (NS) of switch FA. Place the free end of this twisted pair through hole HB near V5 in the chassis. This end will be connected later.
- ( ) At one end of a 6-1/4" twisted pair connect the light wire to lug 5 (S-1) and the dark wire to lug 1 (S-4) of switch FA. Place the free end of this twisted pair through hole HA in the chassis. It will be connected later.

NOTE: Either light or dark hookup wire may be used for point-to-point wiring in the following steps.

- ( ) Connect a 3" length of hookup wire between lugs 2 (S-1) and 7 (S-2) of switch FA.
- ( ) Connect a 1-1/2" length of hookup wire between lugs 4 (S-1) and 6 (S-2) of switch FA.
- ( ) Connect one end of a 3-1/2" hookup wire to lug 1 of terminal strip Y (NS). Place the free end of this wire through hole HA in the chassis. It will be connected later.

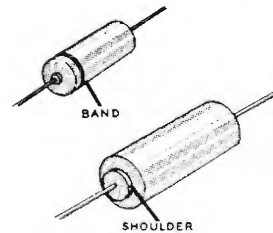

NOTE: When installing the tubular capacitors, be sure that the end marked with a band or shoulder is placed as shown in Pictorial 2.

- ( ) C34. Cut the lead from the unmarked end of a .047  $\mu$ fd tubular capacitor to 3/4". Connect this lead to lug 2 of terminal strip Y (NS). Place the free lead of this capacitor through hole HC in the chassis. It will be connected later. Use sleeving on the lead passing through the chassis hole.
- ( ) C9. Cut the lead from the unmarked end of a .047  $\mu$ fd tubular capacitor to 1/2". Connect this lead to lug 3 of terminal strip Y (NS). Cut the marked lead to 1-1/4" and place this lead through hole HD in the chassis. It will be connected later. Use sleeving on the lead passing through the hole near the tube socket.
- ( ) Referring to Detail 2E, cut the leads of both P.E.C. networks (#84-23). Detail 2E is full size and can be used as a template. Place sleeving over each lead and connect one prepared P.E.C. as follows:

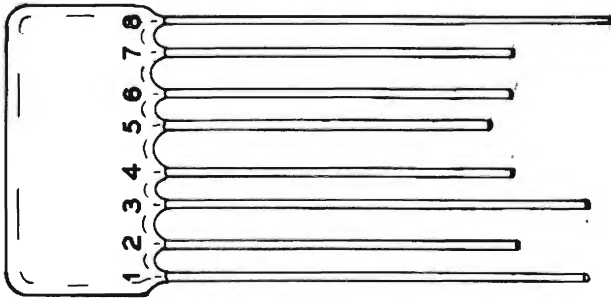

## FULL SIZE

Detail 2E

<u>LEAD NO.</u>	<u>CONNECT TO</u>
( ) 1	lug 3 of terminal strip Y (S-2)
( ) 2	lug 3 of control FC (S-1)
( ) 3	lug 3 of control FB (S-1)
( ) 4	lug 2 of control FC (S-1)
( ) 5	lug 1 of control FC (S-1)
( ) 6	lug 2 of control FB (S-2)
( ) 7	lug 1 of control FB (S-1)
( ) 8	lug 1 of terminal strip Y (NS)
( )	At one end of a 6-1/2" twisted pair, connect the light wire to lug 3 of control FD (S-1). Connect the dark wire through lug 1 (NS) to lug 4 (NS) of control FD. Place the free end of this twisted pair through hole HN in the chassis. It will be connected later.

- ( ) At one end of a 4-1/2" twisted pair, connect the light wire to lug 2 (S-1) and the dark wire to lug 1 (NS) of control FD. Place the free end of this twisted pair through hole HE in the chassis. It will be connected later.
- ( ) Connect a 3" length of hookup wire from lug 1 of control FD (S-4) to lug 9 of switch FE (NS).
- ( ) Connect a 3" hookup wire between lugs 9 (NS) and 3 (NS) of switch FE.
- ( ) At one end of a 4" twisted pair, connect the light wire to double-lug 8 of switch FE (S-1). The dark wire is not connected at this end. Place the free end of this twisted pair through hole HH in the chassis. It will be connected later.
- ( ) At one end of a 5" twisted pair, connect the light wire to double-lug 2 of switch FE (S-1). Connect the dark wire to lug 3 of switch FE (NS). Place the free end of this twisted pair through hole HL in the chassis. It will be connected later.
- ( ) C31. Connect the lead from the marked end of a .1  $\mu$ fd tubular capacitor to lug 4 of switch FE (S-1). Place the free lead of this capacitor through hole HG in the chassis. It will be connected later. Use sleeving on both leads.
- ( ) C6. Connect the lead from the marked end of another .1  $\mu$ fd tubular capacitor to lug 10 of switch FE (S-1). Cut the other lead to 3/4" and place it through hole HM in the chassis. It will be connected later. Use sleeving on both leads.

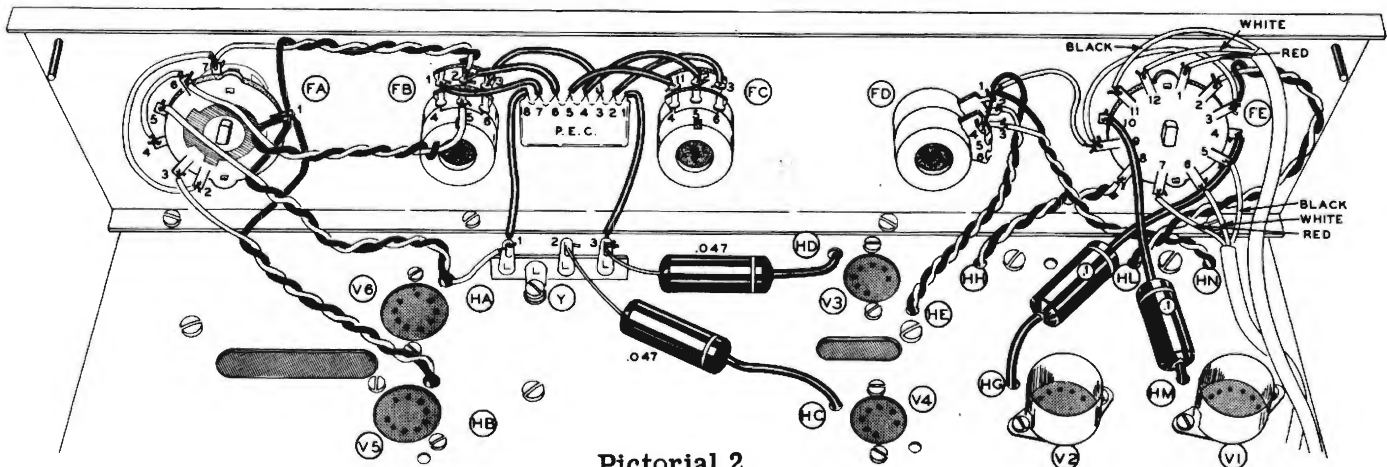

Pictorial 2