A close-up photograph of a Thorens transcription turntable. The turntable is black with a silver-colored metal rim. A tonearm is mounted on the turntable, holding a blue cartridge. The background is a solid blue color. The text "Thorens Transcription Turntables" is overlaid on the left side of the image.

Thorens
Transcription
Turntables

THORENS



The THORENS ISOTRACK-tone arm

For optimum in tracking ability it is not sufficient that a tone arm has low bearing friction. It is much more important that it has a low effective mass, because high mass prevents the stylus from following the imperfections (warp or ripple) of the record as it should do.

To overcome high effective mass one can increase the stylus force, but this results in excessive record wear.

THORENS has solved the effective mass problem by removing any unnecessary weight from the tone arm.

The head shell is reduced to a shielding device, and the detachable connector is placed close to the pivots where it has negligible influence on the effective mass. In addition, the THORENS ISOTRACK is a straight arm and not S-shaped, since a straight line is the shortest possible connection between pivot and stylus and has, therefore, the lowest effective mass.

As can be seen from the picture, the necessary offset angle is independent of the arm shape.

Typical arms have effective masses of around 15 grammes.

The THORENS ISOTRACK is less than HALF this figure, allowing it to track at the lowest possible stylus pressures.

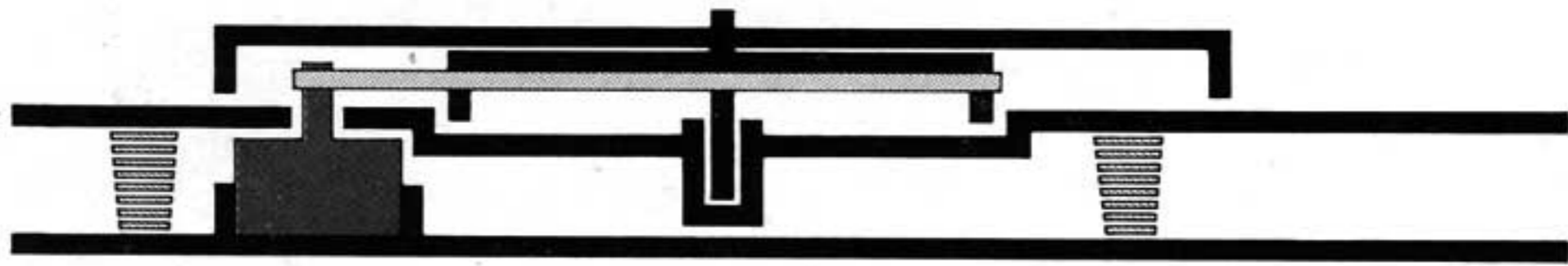

The THORENS floating suspension

Every turntable must be damped by a suspension system to prevent the sensitive pick-up from environmental vibration and from acoustic feedback. If the springs are placed between motor and turntable platter, they then fulfill the additional requirement of decoupling motor vibrations almost completely from the turntable and the pick-up system.

Every THORENS-turntable has such a double chassis system.

The seven pound turntable platter and the tone arm are both mounted on a secondary chassis which is resiliently suspended from the main chassis carrying the motor.

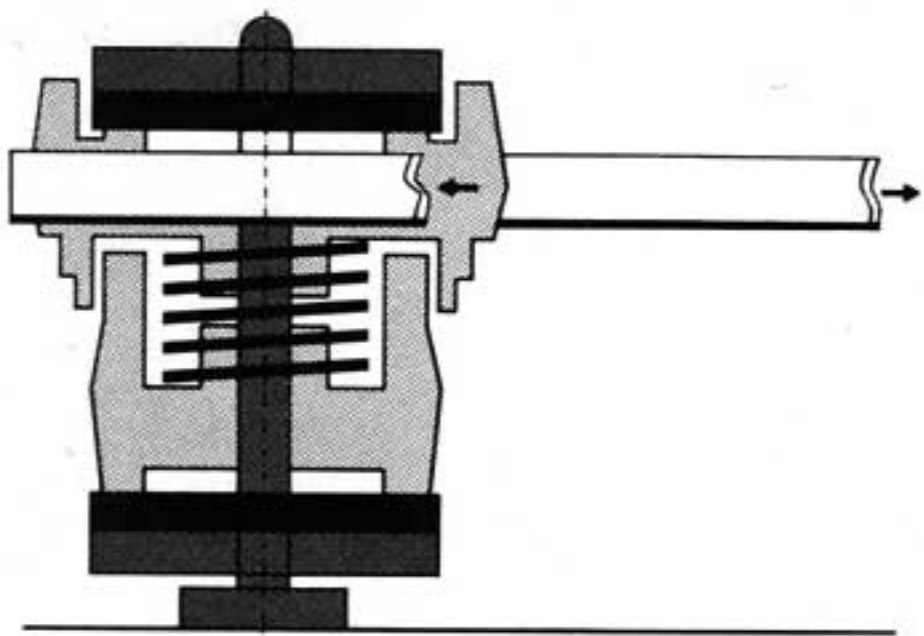

The THORENS belt-drive

The THORENS-motor drives the turntable platter by means of a rubber belt. The natural elasticity of the belt prevents most motor vibrations from reaching the platter and, therefore, the pick-up stylus. In more than 20 years of continuous development, THORENS has reduced the very few disadvantages of belt drive to an absolute minimum and has brought it to a level of technical perfection which is not approached by any other system known today.

A particular development is the THORENS-acceleration clutch, which prevents the belt from stretching, thus reducing the starting time and eliminating chassis vibration.

Because of the high performance required by discerning listeners, THORENS has decided to retain its own unique belt drive system as long as no better drive system is developed in THORENS laboratories or elsewhere.

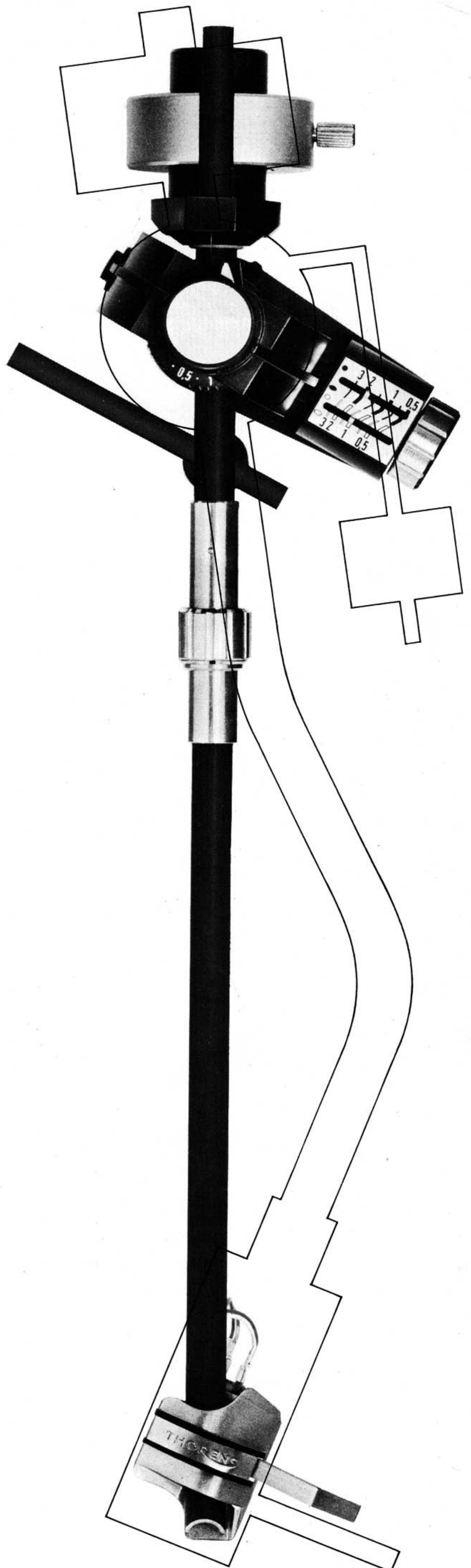

The THORENS drive motor

THORENS-turntables are driven by a 16 pole two-phase synchronous motor. This motor has two identical stators which work on the rotor at an angle of precisely 90°, thus creating a perfectly circular rotating field and resulting in optimum wow and flutter and rumble figures.

This construction also assists in reducing the magnetic stray flux to a minimum, thus preventing any disturbing hum induction on very sensitive pick-up cartridges.

As is the case of any synchronous motor, the speed of rotation is determined by the power frequency and by the number of poles used and, therefore, this will always remain constant regardless of aging, dirt or climatic conditions.

At a mains frequency of 50 Hz the motor rotates at a speed of only 375 rpm, with a speed of 450 rpm at 60 Hz, and because of this low speed, both the motor rumble figure and bearing wear are reduced to the absolute minimum.

Quiet synchronous motors have been proved in nearly one million THORENS-turntables.

The motor is controlled by the mains frequency, thus achieving a speed constant which may be compared with the precision of an electric clock.



TD 160 Mk II

The established basic model of the THORENS-transcription turntable family incorporating all features which have made them famous all over the world.

All controls including the lever operating the TP 16 tone arm lift are situated on the front of the main chassis for easy operation.

TP 16 Mk II ISOTRACK-tone arm

The TD 160 transcription turntable is equipped with the same TP 16 tone arm as used on the electronic THORENS TD 126 Mk II.

The TP 16 tone arm is dynamically balanced in both the horizontal and vertical planes resulting in great insensitivity to external shocks and acoustic feedback, even when playing at the lowest possible tracking force. The distance of 230 mm between the stylus tip and the pivots is the optimum figure resulting from the divergent requirements of a minimum horizontal tracking error and the lowest possible inertia.

The magnesium alloy plug-in shell of the TP 60 combines the lowest inertia with maximum rigidity. The stylus overhang is adjustable in order to accommodate any cartridge with standard 1/2" fixing centres. Dust-proof precision ball races at both the horizontal and vertical pivot points result in minimum friction.

Adjustment of the stylus force is effected by means of a click knob acting on a calibrated spring in precise steps.

Frictionless anti-skate compensation is obtained by means of a sophisticated magnetic bias compensator, calibrated for four different playing modes.

The combination of the above mentioned features results in an arm in which only the technical characteristics of the pick-up cartridge used determine the necessary tracking force to be applied.

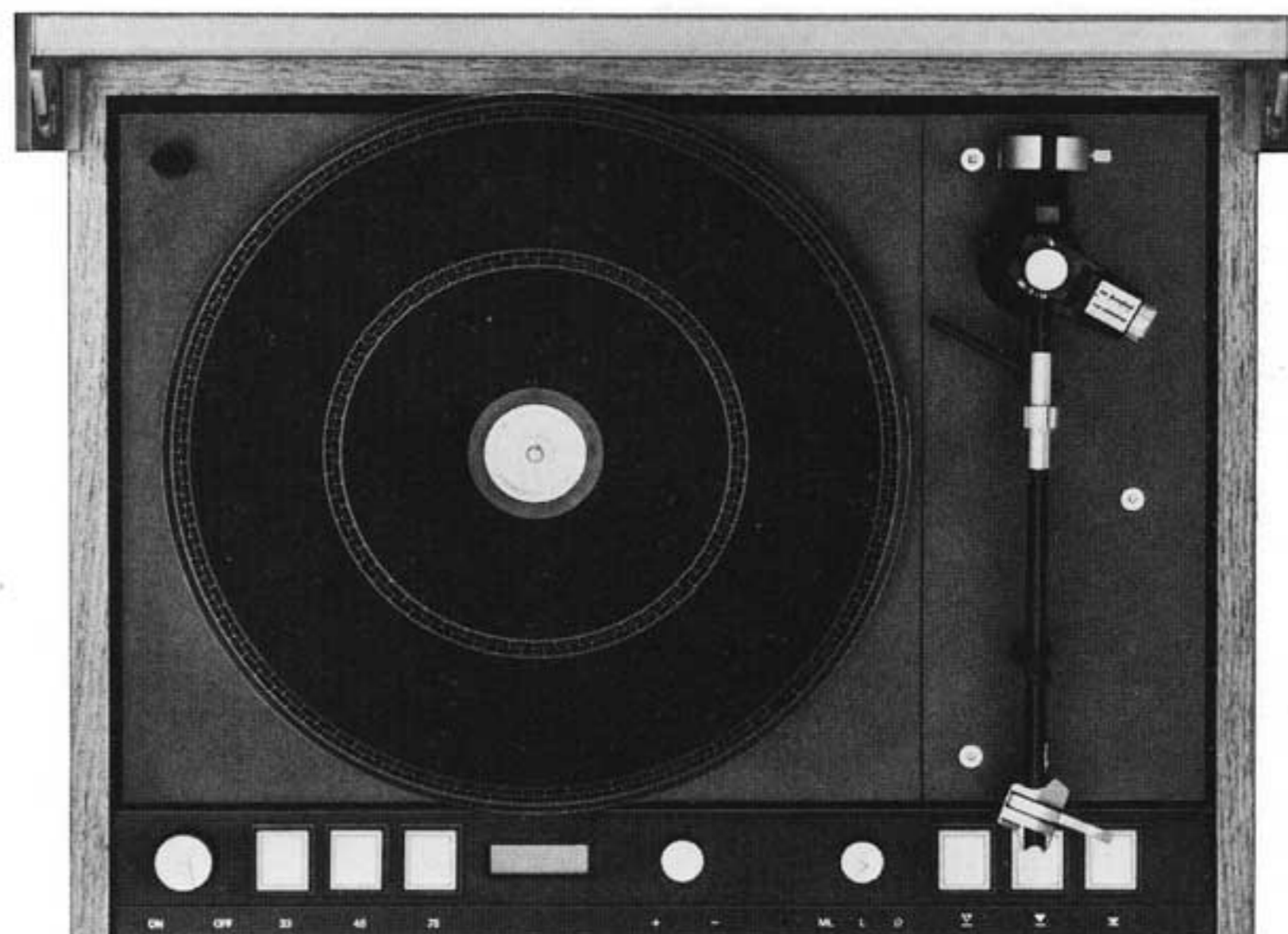

TD 126 Mk II

The TD 126 Mk II electronically controlled turntable is the top-model in the range and is intended for highly sophisticated home music systems and semi-professional application.

The drive motor of the THORENS TD 126 Mk II is supplied by an electronic two-phase generator. This results in even higher speed consistency and better rumble figures. In addition the electronic control permits a pitch variation of $\pm 6\%$ and an electronic velocity alteration for speeds of 33 1/3, 45 and 78 rpm.

The unique end-of-record sensor provides tone arm lift operated by a separate motor and automatic shut-off of the drive motor.

The THORENS automatic stop system is fully electronic, and for professional application its functions may be by-passed.

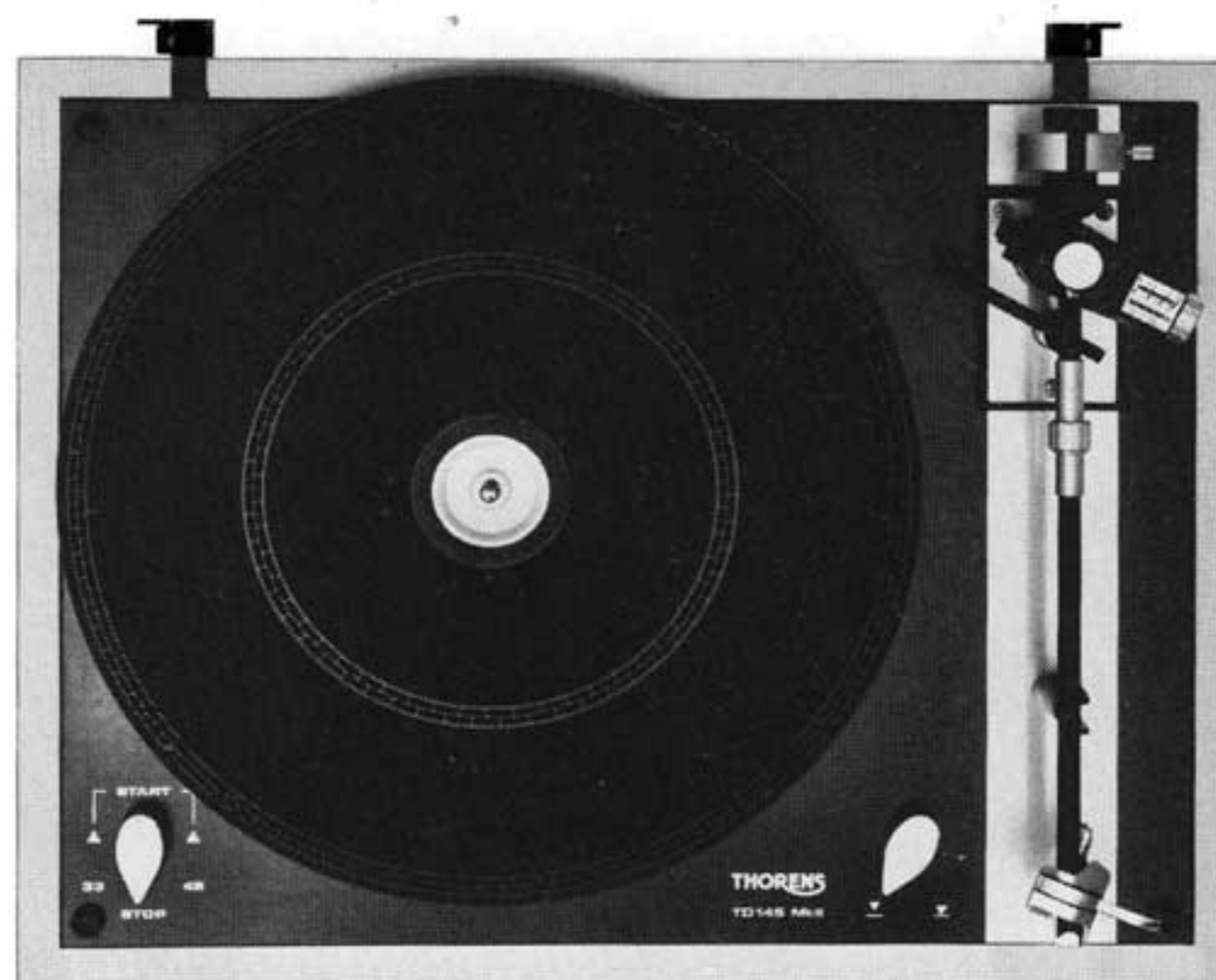

TD 145 Mk II

The THORENS-transcription turntable with electronic auto stop. When the tone arm motional speed increases as it approaches the final lead-out grooves of the record, a control signal is produced by the change in tone arm velocity and picked up by a high frequency sensing element. The command signal is processed and employed to stop the motor and raise the tone arm.

The precision associated with THORENS is further emphasized here, since the actuation of the auto stop process is not position sensitive, but is completely dependent upon the quantity of information contained on the disc.

An ingenious combination of electronic and function switching enables the operator to cue with studio precision at any point on a disc, even at the very centre, with the turntable rotating and tone arm in the lowered position.

The THORENS TD 145 combines a high precision turntable with automatic stop without compromising the performance.

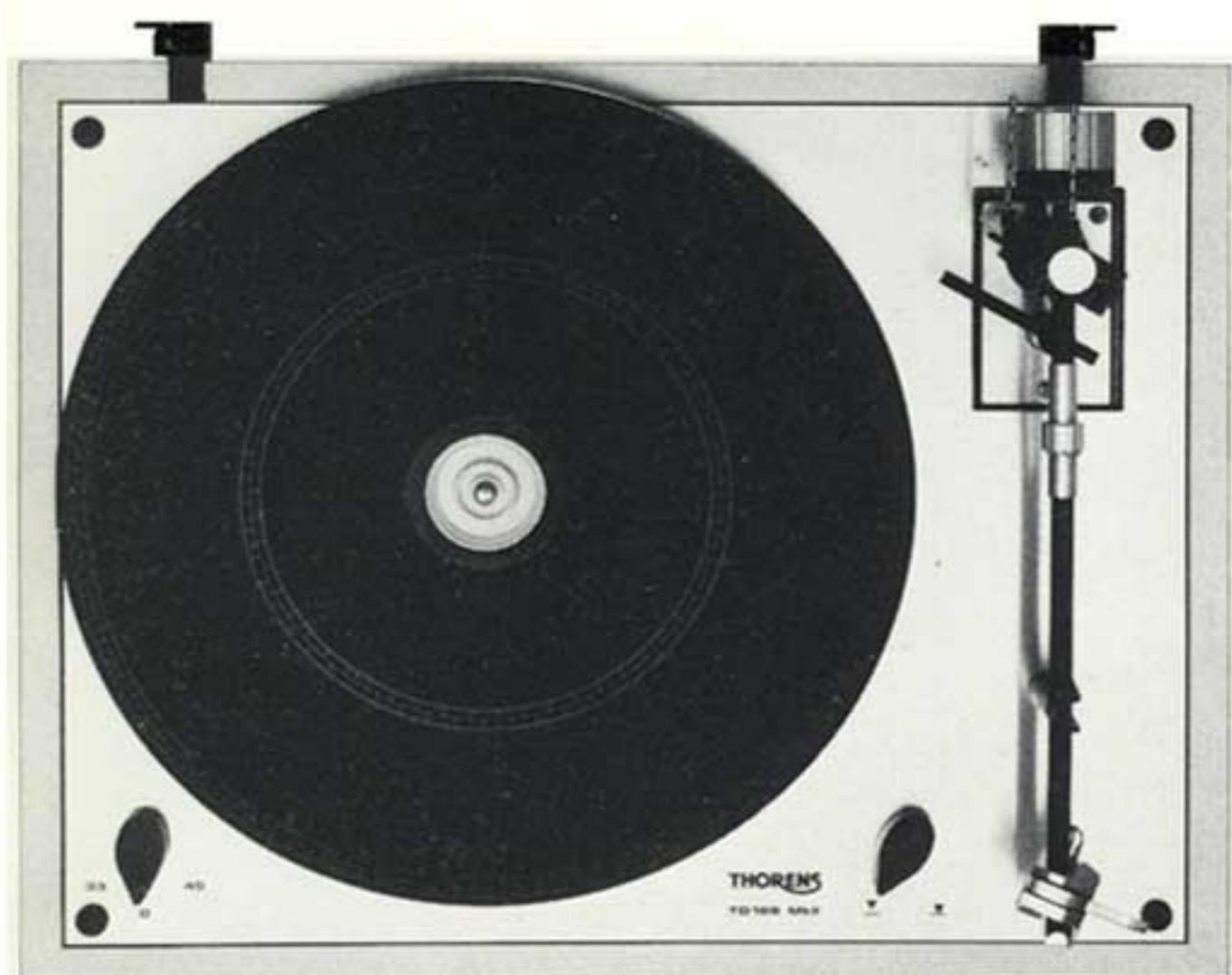

THORENS

TD 166 Mk II

Despite its modest price, the THORENS TD 166 Mk II is a THORENS in every sense of the word. It incorporates many advanced features plus the traditional refinements and quality that are the foundation of THORENS reputation for the world's finest turntable performance. The THORENS TD 166 Mk II drive mechanism combines ingenious simplicity with technical perfection.

The TP 11 ISOTRACK tone arm has been designed to achieve precise longitudinal and lateral balance simultaneously with the adjustment of the stylus force for the cartridge. This latter adjustment is made by means of counter-weights for stylus forces from 0 to 3 g. Vertical precision pivots in combination with a dust proof horizontal ball race result in minimum friction.

Technical Data

	TD 126 Mk II	TD 145 Mk II	TD 160 Mk II	TD 166 Mk II
Drive system	1 step belt-drive	1 step belt-drive	1 step belt-drive	1 step belt-drive
Motor	16 pole two phase synchronous motor with slip clutch for instantaneous start	16 pole two phase synchronous motor with slip clutch for instantaneous start	16 pole two phase synchronous motor with slip clutch for instantaneous start	16 pole two phase synchronous motor with slip clutch for instantaneous start
Speeds	33 $\frac{1}{3}$, 45 and 78 rpm electronical speed selection	33 $\frac{1}{3}$ and 45 rpm mechanical speed selection	33 $\frac{1}{3}$ and 45 rpm mechanical speed selection	33 $\frac{1}{3}$ and 45 rpm mechanical speed selection
Motor speed control	electronical two phase generator	synchronized by mains frequency	synchronized by mains frequency	synchronized by mains frequency
Pitch control	\pm 6%, stroboscope			
Turntable platter	3,2 kg, zinc alloy dynamically balanced	3,2 kg, zinc alloy dynamically balanced	3,2 kg, zinc alloy dynamically balanced	2,7 kg, zinc alloy dynamically balanced
Platter diameter	30 cm (12")	30 cm (12")	30 cm (12")	30 cm (12")
Wow and Flutter according to DIN 45507	less than 0,04%	less than 0,06%	less than 0,06%	less than 0,06%
Rumble unweighted	-50 dB according to DIN 45539	-45 dB according to DIN 45539	-45 dB according to DIN 45539	-45 dB according to DIN 45539
Rumble weighted	-70 dB according to DIN 45539	-65 dB according to DIN 45539	-65 dB according to DIN 45539	-65 dB according to DIN 45539
Tone arm	exchangeable end-tube	exchangeable end-tube	exchangeable end-tube	exchangeable end-tube
Tone arm length	230 mm (9")	230 mm (9")	230 mm (9")	230 mm (9")
Effective mass	7,5 g	7,5 g	7,5 g	7,5 g
Stylus overhang	14,4 mm (9/16")	14,4 mm (9/16")	14,4 mm (9/16")	14,4 mm (9/16")
Offset angle	22°	22°	22°	22°
Lateral tracking error	less than 0,18°/cm of radius	less than 0,18°/cm of radius	less than 0,18°/cm of radius	less than 0,18°/cm of radius
Skating compensation	magnetic force, without friction	magnetic force, without friction	magnetic force, without friction	by weight with nylon string
Stylus pressure appliance	by spring	by spring	by spring	by weight
Horizontal friction	\leq 25 mg	\leq 25 mg	\leq 25 mg	\leq 30 mg
Vertical friction	\leq 25 mg	\leq 25 mg	\leq 25 mg	\leq 30 mg
Auto-stop	electronic velocity sensor	electronic velocity sensor		
Fitting of pick-up cartridge	for all standard $\frac{1}{2}$ " cartridges	for all standard $\frac{1}{2}$ " cartridges	for all standard $\frac{1}{2}$ " cartridges	for all standard $\frac{1}{2}$ " cartridges
Mains voltage	110-125 V, 210-240 V AC 50/60 Hz	110-125 V, 210-240 V AC 50/60 Hz	110-125 V, 210-240 V AC 50/60 Hz	110-125 V, 210-240 V AC 50-60 Hz
Power consumption	15 Watt	2,5 Watt	2,5 Watt	2,5 Watt
Dimensions (with dust cover)	50,5 x 39,5 cm	43 x 36 cm	43 x 36 cm	43 x 36 cm
Height (with dust cover)	17 cm	15 cm	15 cm	15 cm
Weight	15,5 kg	9 kg	9 kg	8,5 kg



THORENS