

FM STEREO/FM-AM TUNER **ST-5130**

Owner's instruction manual



The ST-5130 incorporates the most advanced SONY techniques in fm tuner technology and full utilization of the available devices. The MOS FET's, other all silicon transistors, and solid-state filters employed in the ST-5130 are specially designed to bring out the most in your tuner.

Sensitivity, interference rejection, and other vital factors which affect the quality of a tuner are greatly determined by the characteristics of the front end. The front end of the ST-5130 has MOS FET's in the mixer and r.f. stages, thus it achieves exceptionally high sensitivity, overload capability, image rejection, superior cross-modulation rejection, and low internal noise. The ST-5130 delivers clean audio output even if the unit is operated near a powerful transmitter, or receives very weak stations in distant fringe areas.

The fm i.f. section has eight solid-state filters (which are permanently-aligned ceramic filters) to contribute to the tuner's selectivity and long-term stability. The solid-state filters permit reception of weak signals without interference from strong adjacent stations.

The a-m tuner employs high performance transistors to maintain high sensitivity, with superior signal-to-noise ratio. Its excellent linearity and dynamic range assure low distortion at any strength signal. A-m programs will be received with an audio quality that will surprise hi-fi oriented ears.

The ST-5130 also offers you the newest development in tuner design.....the Impulse Noise Suppressor.

Conventional tuners, even those of high quality, are inevitably affected by impulse-noise caused by ignition, fluorescent lights, generators, or motors. When impulse noise occurs, the amplitude of the input signal is disturbed by the impulse. If the impulse is too strong to be removed by the limiter characteristic of the tuner, the impulse remains audible. In the SONY INS system, the pulse discriminator is activated when the noise pulse occurs, and cuts the disturbed signals momentarily. The pulse begins and ends within so short a time that the human ear does not notice the "hole" in the sound, and hears the program clearly. This system is especially effective in fm recording.

An effective muting circuit silences all interstation noise as you tune from station to station. This protects the speakers and makes tuning a silky-smooth operation.

The quality of your fm reproduction depends greatly on the signal condition. The ST-5130 offers a center-channel tuning-meter, a tuner-input level meter, a 75-ohm coaxial input connector and multipath outputs.

Read this instruction manual carefully and save it for future reference in order to take full advantage of all the features of this fine tuner.

TABLE OF CONTENTS

PREPARING FOR USE	
UNPACKING	1
SYSTEM CONNECTIONS.....	2
Notes on Connections	3
Antennas	4
Output Connections	6
Ground Connection	6
Fm Multipath Output Connections	6
Representative Multipath Indications.....	7
Power Connection	8
CUSTOM MOUNTING	8
OPERATING INSTRUCTIONS	
FUNCTION AND LOCATION OF CONTROLS	8
HOW TO RECEIVE FM PROGRAMS	10
HOW TO RECEIVE AM PROGRAMS	10
LEVEL CONTROLS.....	10
CARE OF YOUR TUNER	
CLEANING.....	11
TROUBLE CHECKS.....	11
REPACKING FOR SHIPMENT	11
TECHNICAL DATA	
TECHNICAL SPECIFICATIONS	12
BLOCK DIAGRAM	13
OPERATING CURVES	14

PREPARING FOR USE

UNPACKING

All SONY equipment comes to you carefully packed in cartons designed to withstand the rigors of shipment. Do not throw the carton or associated packing material away; they will come in handy if you ever have to transport or ship the ST-5130.

Inspect your ST-5130 immediately for signs of damage incurred in transit. If damage has occurred, consult your local SONY dealer for further instructions. Once again, save all packing material; it will substantiate your damage claim.

SYSTEM CONNECTIONS

No doubt you have already decided on a location for your ST-5130. However, before going ahead with the installation, make sure that your choice of location agrees with the following list of DO's and DON'T's.

- DO** allow at least one inch clearance around the ST-5130 for ventilation.
- DO** allow sufficient room behind the ST-5130 so you can make connections to the rear panel without disrupting your entire setup.
- DON'T** remove the chassis cover. Refer servicing to qualified personnel.
- DON'T** place the ST-5130 in direct sunlight, or near radiators, hot-air ducts, or any other source of heat. The ST-5130 must not be operated where the room

temperature is over 110°F. Similarly, don't place it in any area subject to freezing temperatures or excessive moisture.

- DON'T** place the ST-5130 on any soft surface which may block the bottom ventilation holes. Similarly, don't place anything on top of the cabinet which might block the top ventilation holes.
- DON'T** connect the ST-5130 to other than the specified power sources (120 volts 60 Hz).
- DON'T** make connections with the power turned on.

After you have found a suitable location for your unit, you can begin making the basic connections described in the following paragraphs. Refer to the overall-system connection diagram while making these connections.

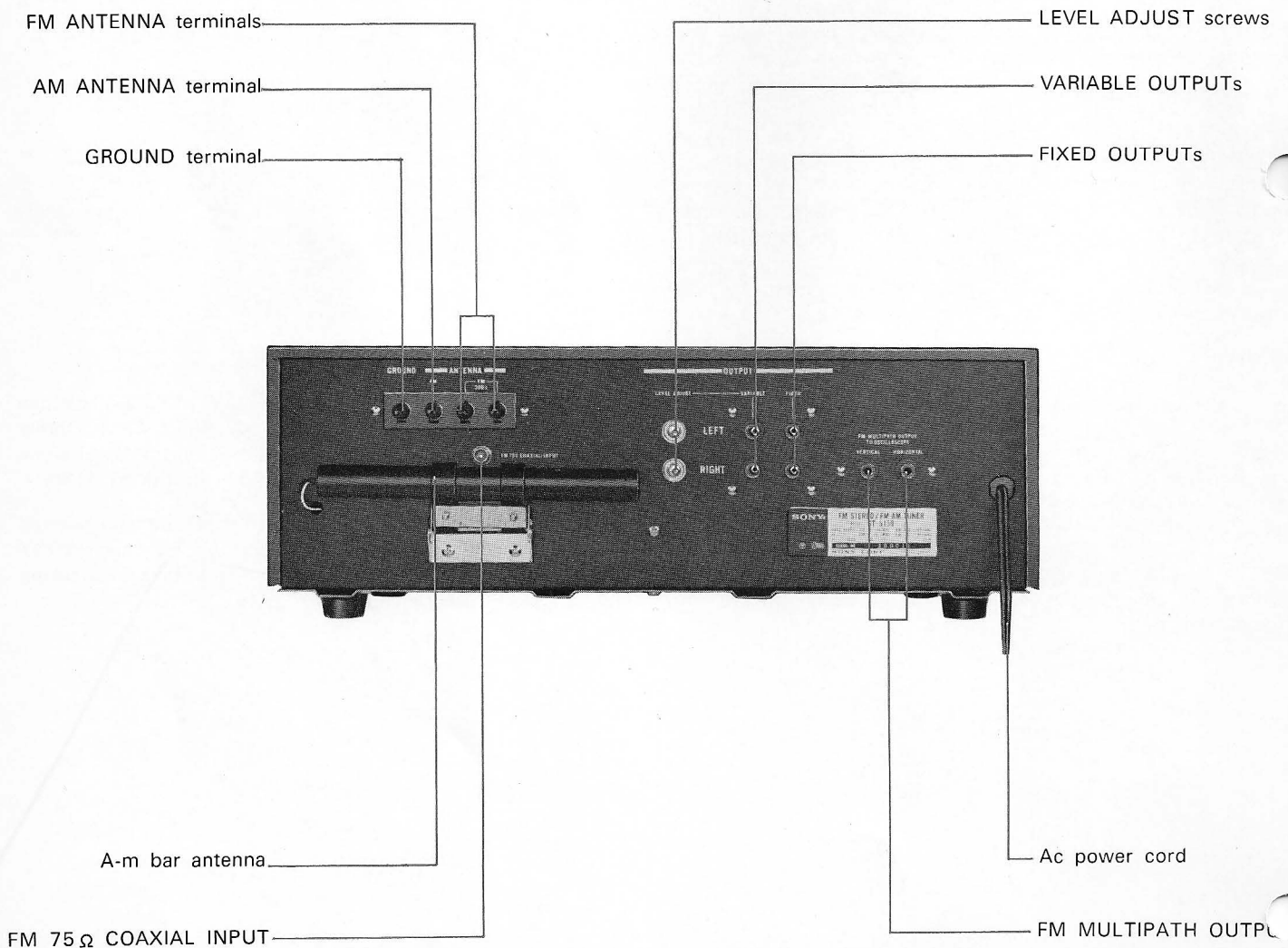

Notes on Connections

To assure correct matching at the input and output terminals of your sound system, refer to the table of "TECHNICAL SPECIFICATIONS" for the ST-5130 (on page 12), and the specifications given in the instruction manuals provided with the components you wish to connect to the ST-5130.

Be sure the cable connectors are fully inserted into the jacks. A loose connection may cause hum and noise.

When reconnection is required, turn the amplifier's volume control counterclockwise.

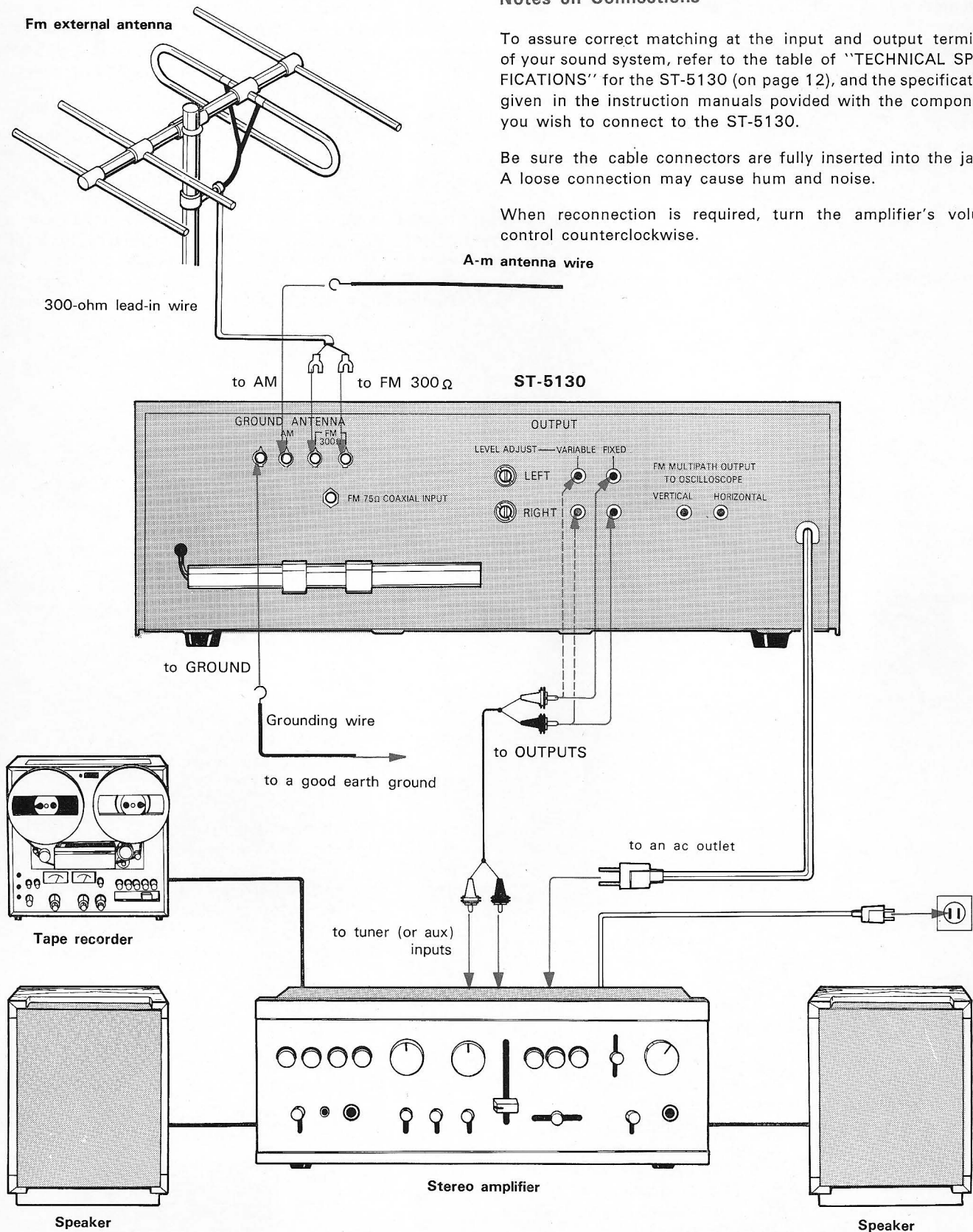

Antennas

The sensitivity of the ST-5130 is so great that in most areas it will work well with simple antennas such as the ribbon dipole antenna. However, for the very best fm reception possible, particularly at problem locations, a more elaborate antenna may be necessary.

The factors determining the minimum antenna requirements for your location include the following:

1. How strong are the fm signals in your neighborhood?
2. Are all the fm stations in the same direction, or are they scattered all over?
3. Is multipath reception a problem?

Ribbon dipole antenna, rabbit ears type antenna

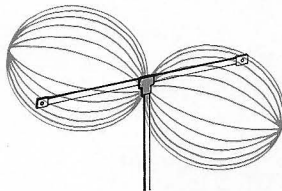

Dipole antenna picks up signals from both the front and rear equally well.

Directional outdoor antennas

Increased sensitivity to front signals

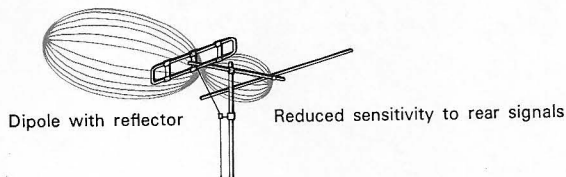

Dipole with reflector

Reduced sensitivity to rear signals

High frontal sensitivity

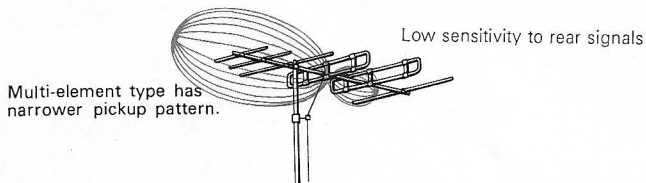

Multi-element type has narrower pickup pattern.

As far as signal strength is concerned, many city dwellers do extremely well using just a ribbon-type fm dipole or the familiar "rabbit ears". The rabbit ear antenna is the more preferable of the two since it can easily be rotated and otherwise adjusted for best reception. However, in the far suburbs, a high-gain highly-directional outdoor fm antenna is necessary to secure the best signal-to-noise ratio on stereo broadcasts.

Omnidirectional antennas are quite handy if the local fm stations lie in different directions and you don't want to use a rotator. However, if "fm ghosts" (multipath reception) cause the problems described in the next paragraph, you must use a highly-directional antenna and rotator, or several highly-directional antennas.

Multipath Reception: Good fm reception depends not only on the sensitivity of the ST-5130 but on the quality of the received signal. The most important factor affecting signal quality is "multipath" reception. Multipath reception is the arrival of a signal at an antenna from several points, the result of signal reflections from tall buildings or bridges, just to cite a few examples. These signals arrive at the antenna at different times, depending upon the lengths of the paths they travel. The addition of these signals at the ST-5130 can produce audible distortion and loss of channel separation. Multipath reception is a condition that depends solely upon the terrain of the surrounding locality.

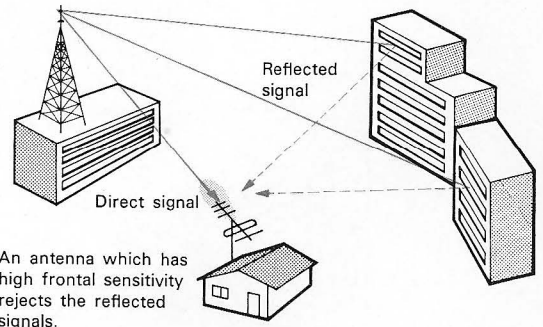

An antenna which has high frontal sensitivity rejects the reflected signals.

Multipath reception can be avoided to a great extent by using shielded twinlead or coaxial cable, and a good directional antenna that is correctly oriented.

Connecting the Fm Antenna Lead: The ST-5130 accepts either 300-ohm transmission line (twin lead) or 75-ohm coaxial cable. The 300 ohm twin lead may be either the standard or shielded type. Standard 300 ohm twin lead is inexpensive and will be perfectly adequate for most installations. However, in cases where local noise or multipath pickup on the transmission line causes interference, a shielded transmission line must be used.

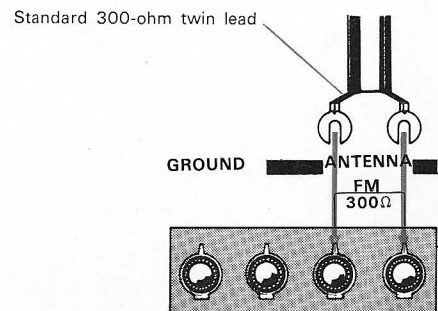

connect standard 300-ohm twin lead to the ST-5130, loosen the FM 300Ω ANTENNA terminals. Strip the plastic insulation from the two-conductor lead-in wire and wrap each conductor around a terminal. Tighten the terminals.

To connect shielded 300-ohm twin lead to the ST-5130, connect the two conductors as described above, then connect the shield drain wire to the GROUND terminal.

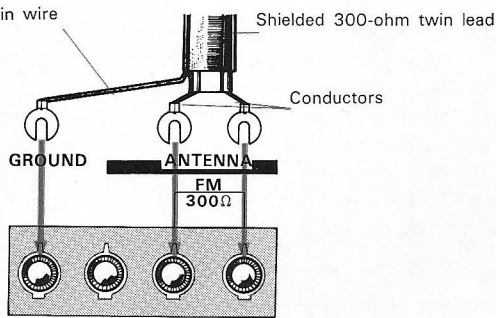

To obtain minimum signal leakage and pick-up on the line, observe the following precautions, when using standard 300-ohm lead-in wire.

- When installing the outdoors antenna lead, use stand-off insulators (available on the market) to route the lead over the roof, outer wall, etc.
- Keep the lead as short as possible and avoid long horizontal runs.
- Do not fold the unused portion of the lead at the input of the tuner.

If you must run the antenna lead for a long distance and/or through walls or floors, the use of 75-ohm coaxial cable or shielded twin lead is recommended. In addition, coaxial cable and shielded twin lead are impervious to acid, humidity and weathering effects.

To connect 75-ohm coaxial cable to the ST-5130, attach the supplied connector as described below and connect the cable to the FM 75Ω COAXIAL INPUT. Type RG-59U cable is ideal for use in this application.

1. Cut and remove the outer covering.
2. Remove the shield braid.
3. Remove the inner covering.
4. If the center conductor is a stranded type, twist the strands tightly and solder them. Do not use too much solder.
5. Pass the ring through the cable. Spread the braid.
6. Push and thrust the connector plug into the cable between the braid and the inner covering.
7. Cut the excess braid.
8. Fasten the ring with lineman's plier.
9. Let the center conductor protrude approx. $\frac{1}{8}$ inch; cut off the excess conductor.

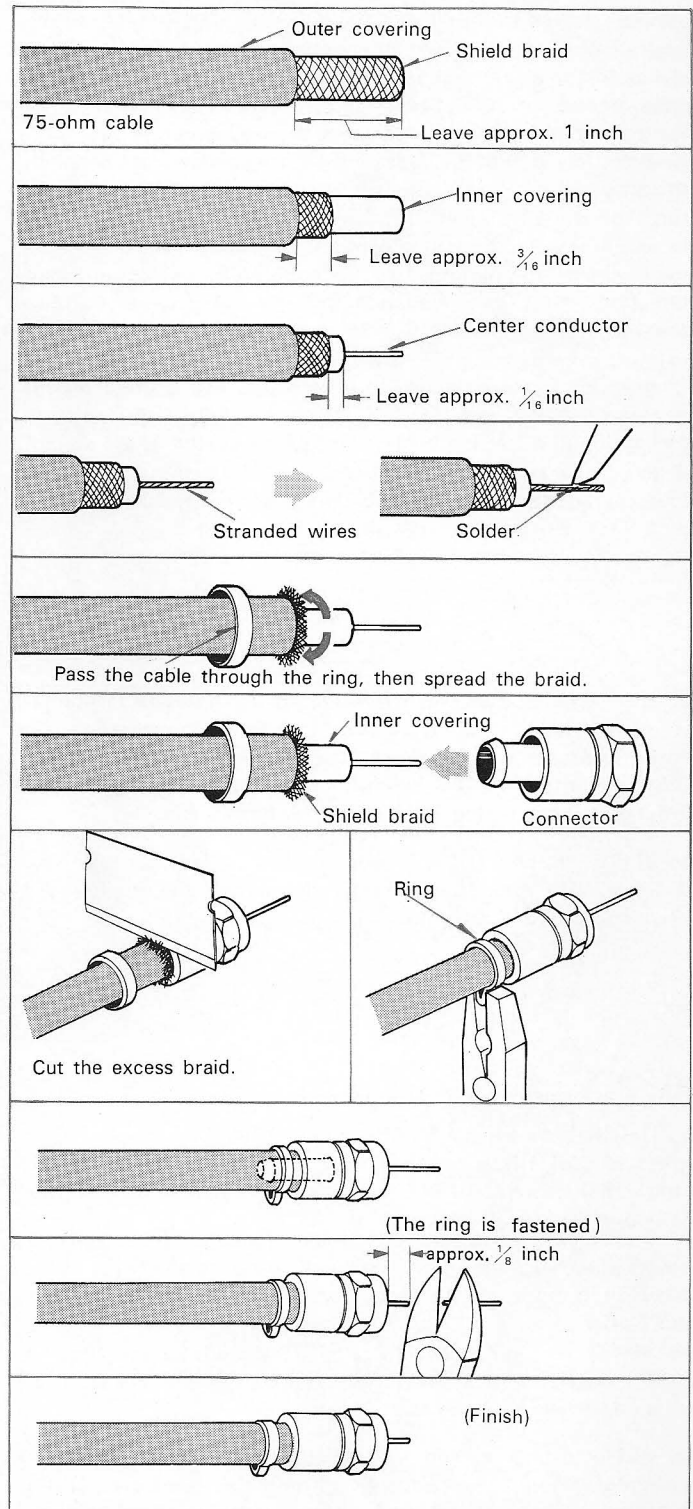

Antenna Orientation: First, tune in the desired station by adjusting the TUNING knob, then adjust the antenna direction and height for clearest sound. The signal strength is indicated by the amount of deflection of the TUNER INPUT meter. The stronger the signal, the greater the deflection.

- If distortion is audible, adjust the direction and/or height of the antenna until the distortion is eliminated. Often, a slight turn will be sufficient.
- In some cases multipath reception on two or more stations may require the antenna to be pointed in several different directions. An effective and relatively inexpensive solution to this problem is the use of a remote-controlled antenna rotator.
- If an outdoor antenna cannot be erected, use a good indoor antenna ("rabbit ears" are satisfactory). Adjust the antenna for minimum distortion by listening to the quality of the sound.
- If an oscilloscope is available, use it to adjust the antenna for least multipath effect as described in "Oscilloscope Connections and Use" on the right column.

A-m Reception: Pull down the built-in bar antenna located at the rear of the set. In most cases, this ferrite-bar antenna will provide optimum a-m reception. In difficult reception areas an outdoor antenna will be helpful. Connect a length of wire, 20-50 feet long, to the AM ANTENNA terminal.

The signal strength of the a-m station is indicated on the TUNER INPUT meter; the stronger the signal, the greater the deflection toward the right.

Output Connections

The OUTPUT terminals (FIXED and VARIABLE) supply audio signals to the TUNER or AUX input terminals of your amplifier. Both FIXED and VARIABLE outputs are provided to suit the needs of your amplifier.

Be sure to connect the LEFT channel output of the tuner to the left-channel input of the amplifier, and do likewise for the RIGHT channel.

The FIXED terminals provide fixed 750 millivolt outputs. A SONY stereo amplifier or any high-quality amplifier can be connected to these outputs.

The output levels at the VARIABLE terminals can be varied continuously from 0 to 2 volts by turning the associated LEVEL ADJUST screws. These outputs are useful in equalizing the volume produced by the tuner with that provided by other signal source such as tape players, phonograph, etc.

If a monophonic amplifier should be used with the ST-5130, connect either the LEFT or RIGHT output terminal to the proper input terminal of the amplifier. Operate the ST-5130 with the FUNCTION selector set to FM MONO (or AM).

Ground Connection

Connect the GROUND terminal to a good earth ground with grounding wire. A direct earth ground (preferably a cold-water pipe) is recommended for lightning protection when an external antenna is used.

Fm Multipath Output Connections

The ST-5130 MULTIPATH OUTPUTS permit visual and audible checks of multipath pickup. If you use an oscilloscope, use Procedure A, if you do not, use Procedure B.

The signals at the FM MULTIPATH OUTPUT jacks are as follows: The HORIZONTAL output is proportional to the audio level of the broadcast signal.

The VERTICAL output is proportional to the amplitude modulation caused by the time lag between the direct signal and the additional signal.

A. Multipath check with an oscilloscope

1. Connect the FM MULTIPATH OUTPUTS to an oscilloscope as illustrated below.
2. Tune in the desired station (either stereo or mono) while watching the TUNING meter.
3. Adjust the sensitivity of the oscilloscope so that the horizontal and vertical deviation do not go beyond the oscilloscope scale (5 mV/cm is recommended).
4. Observe the trace on the oscilloscope. The less the vertical trace is, the clearer is signal you receive.

With the use of an antenna rotator, point the directional antenna in one direction, then another. Orient the antenna in the direction where the trace shows the most uniform curve. In this position little or no multipath is present. For future reference, write down the rotator's position for that station.

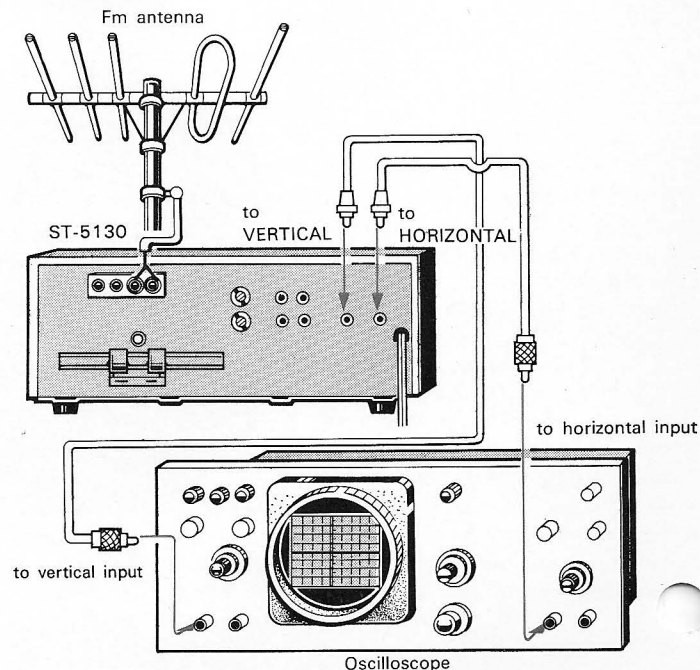

Representative Multipath Indications

Sufficient antenna input level

Weak antenna input level

Uniform and smooth trace
with little or no multipath
(Ideal)

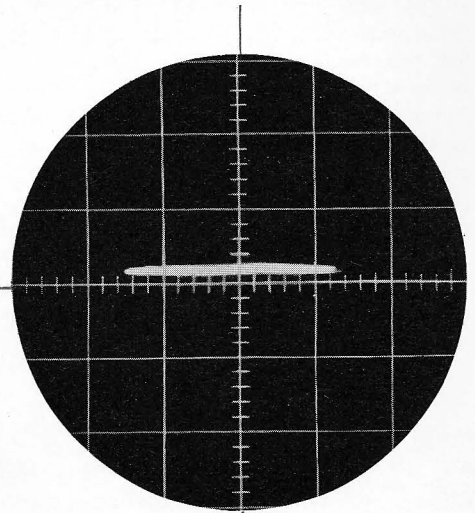
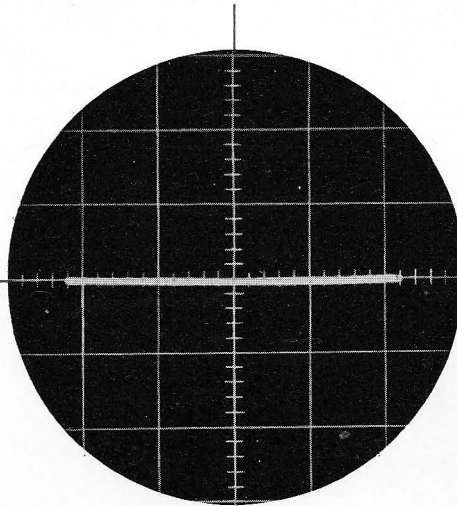

A little multipath
(Acceptable)

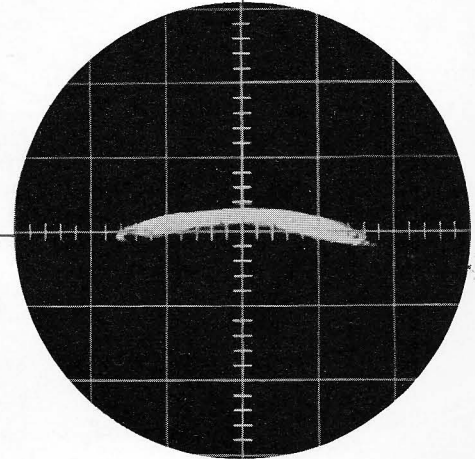
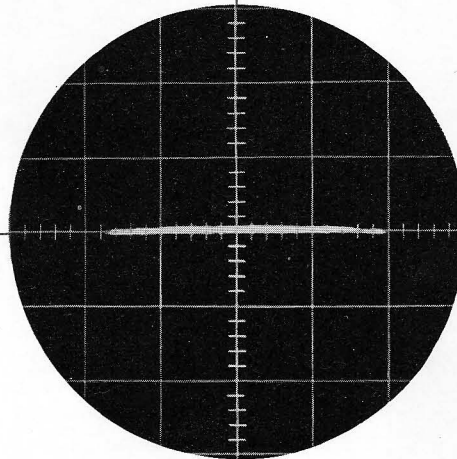

Irregular trace
with severe multipath
(Unacceptable)

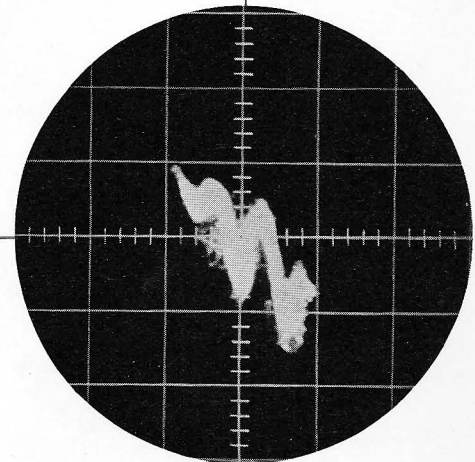
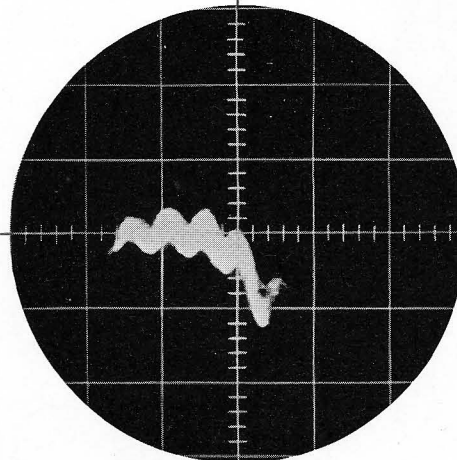

OPERATING INSTRUCTIONS

B. Multipath check with your stereo system

1. Connect the FM MULTIPATH OUTPUTS to the AUX inputs of your amplifier; HORIZONTAL OUTPUT to AUX left-channel input, and VERTICAL OUTPUT to AUX right-channel input.
2. Set the amplifier's function selector to AUX, and the amplifier's mode selector to STEREO.
3. Tune in the desired station (either stereo or mono) while watching the TUNING meter. The program will be heard through the left speaker. The multipath signal will be heard through the right speaker.
4. With an antenna rotator, orient the antenna in the direction where the noise and distortion of the right speaker are minimized. In this position little or no multipath is present. For future reference, write down the rotator's position for that station.

Power Connection

Before making any form of power connection, make sure the POWER switch is set to OFF. Then you can plug the ST-5130's line cord into the electrical outlet (120 V).

CUSTOM MOUNTING

The complete line of SONY Stereo High-Fidelity components are styled with the same simple but elegant lines so that complete systems can be assembled with a truly unitized appearance. Therefore, each can fit into the handsome walnut cabinet Model TAC-1N, available as an optional accessory.

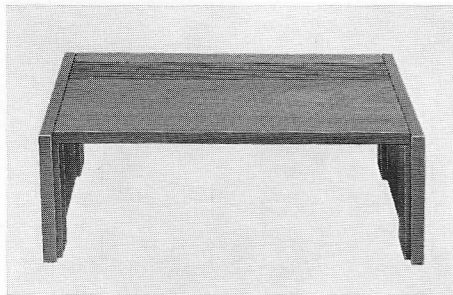

FUNCTION AND LOCATION OF CONTROLS

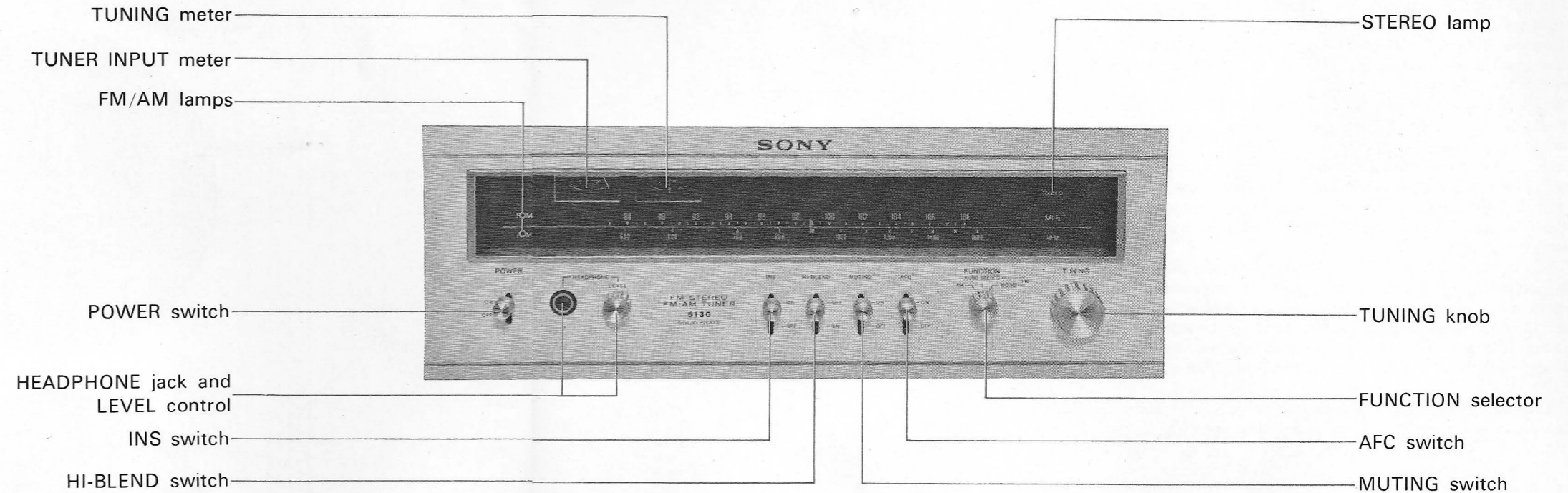

TUNING meter and TUNER INPUT meter

For fm: Fm reception is indicated on these two meters. TUNING meter acts as a zero-center meter to pinpoint the correct channel center of the selected station. Detuning from the center point of the selected station will cause the needle to swing either left or right. The needle will also show a zero-center reading when the tuner is tuned to an unused channel or exactly between channels. The signal strength of the selected station is indicated by the TUNER INPUT meter.

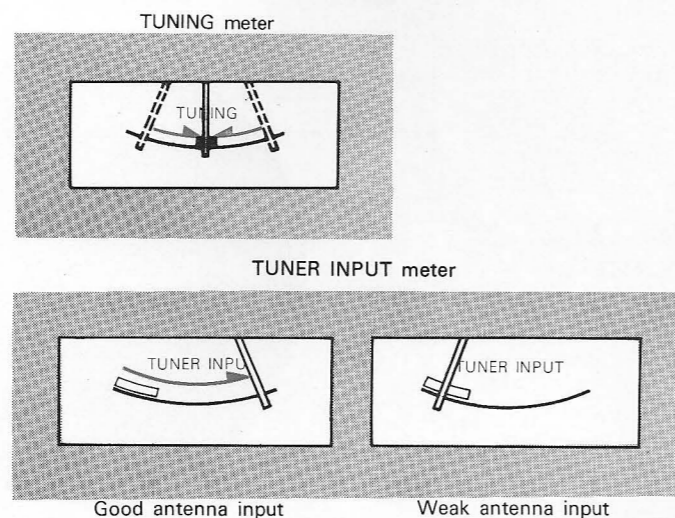

For a-m: Correct tuning and the signal strength on a-m reception are indicated by the TUNER INPUT meter. The relative strength of the received signal is shown by the amount of deflection. The rightmost reading shows the best tuning.

MUTING switch

Usually set this switch to ON, and the fm interstation noise is eliminated while tuning from station to station. Very weak stations which may also be muted along with the noise, however, must be tuned with the switch OFF. In this case, keep the volume down when detuning to avoid the sudden change of noise level.

HI-BLEND switch

Usually set this switch to OFF. If an fm program is very weak and contains back-ground hiss or static, set the switch to ON. This automatically activates the high-blend circuit to blend the high-frequency components of the left and right channels. Thus, the cancellation of noise is accomplished without affecting frequency response.

When an fm program is strong enough but interference noise is still noticeable, this switch will be highly effective.

INS switch (Impulse Noise Suppressor)

Usually set this switch to ON. When impulse noise, such as ignition, fluorescent-light, or neon-sign noise, etc. is received, the INS switch is automatically activated and eliminates the noise components without changing the frequency response or reducing stereo separation. Thus, this facility is especially effective in fm recording.

STEREO lamp

Lights when the tuner receives fm programs of sufficient signal strength by setting the FUNCTION selector to FM AUTO STEREO.

HEADPHONE jack and LEVEL control

Accepts low- or high-impedance headphones. The HEADPHONE output level can be controlled with the associated control knob.

AFC switch (Automatic Frequency Control)

Effective only for fm programs. This switch locks the tuner on an fm station to prevent drifting or fading, and to keep out noise and sideband hiss. When tuning, set this switch to OFF and tune in your desired fm station precisely. After tuning, set this switch to ON.

FUNCTION selector

AMfor a-m reception.

FM AUTO STEREO.....for fm reception. Usually, set the selector to this position. When a stereophonic program of sufficient strength is received, a detector in the MPX section automatically switches the tuner to the stereo mode and the STEREO lamp lights. If the program changes to monophonic, or the program is too weak or unstable to yield enjoyable stereo reception, the tuner will operate monophonically, and the STEREO lamp will not light.

FM MONOlocks the tuner to monophonic operation. Use this position when the fm program is weak and noisy.

HOW TO RECEIVE FM PROGRAMS

1. Flip the POWER switch to ON. The dial scale and the meters light up in green when the tuner is on.
2. Turn on the amplifier you are using with the ST-5130.
3. Set the amplifier's function selector to TUNER or AUX on which the ST-5130 is connected.
4. Set the FUNCTION selector to FM AUTO STEREO. Leave the MUTING, HI-BLEND and INS switches in their normal (upper) positions.
5. Set the AFC switch to OFF and tune in the desired station by turning the TUNING knob. Tune for a zero-center reading on the TUNING meter. After correct tuning is obtained, set the AFC switch again to ON. This locks the tuner on the tuned in signal.

The STEREO lamp lights when a multiplex fm stereo broadcast is received. If the stereo signal shifts to monophonic, the lamp goes out indicating that the tuner has automatically switched to monophonic reception. When an fm stereo signal is too weak or noisy for enjoyable stereo listening, the STEREO lamp will flicker. In this case, set the FUNCTION selector to FM MONO.

6. Adjust the sound level and tone quality to your preference by turning the volume, bass and treble controls of your amplifier.

HOW TO RECEIVE AM PROGRAMS

1. Turn on the tuner and the amplifier.
2. Set the amplifier's function selector to TUNER or AUX on which the ST-5130 is connected.
3. Set the FUNCTION selector to AM. The INS, HI-BLEND, MUTING and AFC switches have no effect upon a-m reception.
4. Tune in the desired station by turning the TUNING knob. Tune for maximum reading on the TUNER INPUT meter.
5. Adjust the sound level and tone quality to your preference with the amplifier's controls.

LEVEL CONTROLS

If the VARIABLE OUTPUTs are being used, adjust the semifixed LEVEL ADJUST screws as follows:

1. Play a record at a normal listening level. Set the mode switch of an amplifier to the monophonic mode and adjust its balance control for equal output from right and left speakers.
2. Switch the input selector on your amplifier to tuner and set the amplifier's mode switch to stereo.
3. Set the FUNCTION selector of the ST-5130 to FM MONO.
4. Compare the volume level of the phonograph with that of the tuner by switching the amplifier's input selector back and forth between phono and tuner.
5. Adjust the LEVEL ADJUST screws on the ST-5130 to produce the same volume as the phonograph. Turn these screws counterclockwise to decrease the volume. Make sure you keep the amplifier's volume control at the original setting (Step 1) while the output-level adjustments are being made.

NOTE: For best result, be sure to balance the volume of both left and right channels precisely.

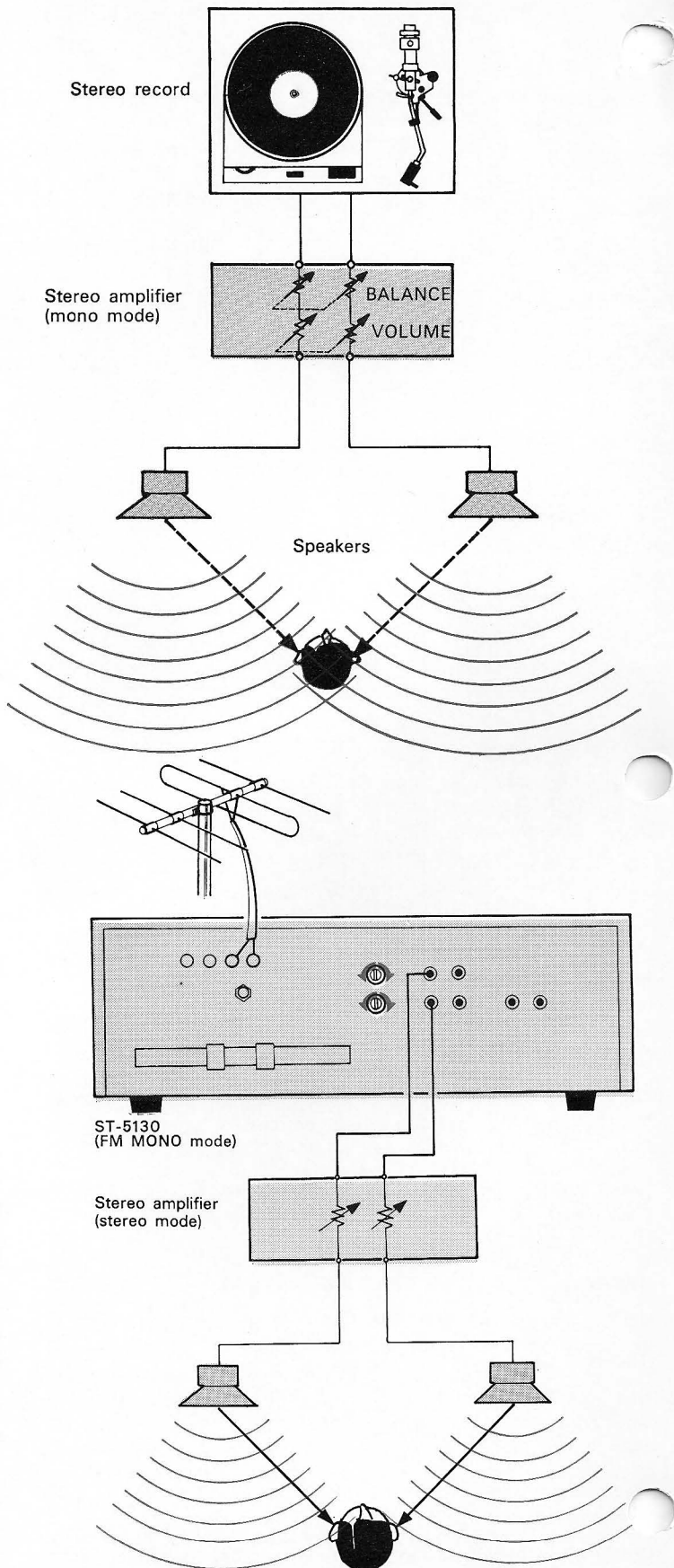

CARE OF YOUR TUNER

CLEANING

Finger prints, the children's chocolate candy, and similar household annoyances can mar the beauty of your ST-5130. These can be cleaned up by wiping the panel, knobs or dial glass with the supplied polishing cloth or a soft clean cloth moistened with water. Do not use any type of scouring powder, abrasive pad, or solvent.

TROUBLE CHECKS

If trouble with your ST-5130 arises, make the following simple checks to determine if the trouble is really in the ST-5130 or external to it. Quite often hi-fi equipment fails to work properly because of incorrectly made system connections. If the trouble persists after you have made these checks, consult your SONY dealer for further instructions.

TUNER INPUT and TUNING meters work, but no audio output.
Check the connections.

TUNER INPUT meter is unstable.
Signal flutter due to aircraft or multipath. Adjust the antenna.

STEREO lamp does not light when receiving stereo programs.
Keep the FUNCTION selector at FM AUTO STEREO.
Adjust the antenna to yield sufficient antenna input level.

STEREO lamp flickers.
If the TUNER INPUT meter shows weak antenna input, use an outdoor antenna. A multielement type is recommended. If the meter shows sufficient level but an unstable reading, adjust the antenna to eliminate multipath reception.

Severe hum or noise.
Use shielded connection cables.
Avoid long horizontal runs of antenna lead.
Keep connection cables (or antenna lead) away from transformers or generators, and at least 10 feet from TV sets and fluorescent lights. Ground the tuner. Do not tangle the antenna lead with an ac power cord.

Volume level is too high or too low.
Reconnect the amplifier to the VARIABLE outputs and adjust the output level of the tuner.

Ignition noise
Tune accurately and set the INS switch to ON. Do not install the outdoor antenna facing toward heavy traffic.

Electrostatic charge
Ground the tuner to a good earth ground.

REPACKING FOR SHIPMENT

The ST-5130's original shipping carton and packing material (which we asked you to save) is the ideal container for shipping the unit for repair work, or simply to another location. However, to achieve the maximum protection, the ST-5130 must be repacked in this material precisely as before. The proper repacking procedure is as shown in this illustration.

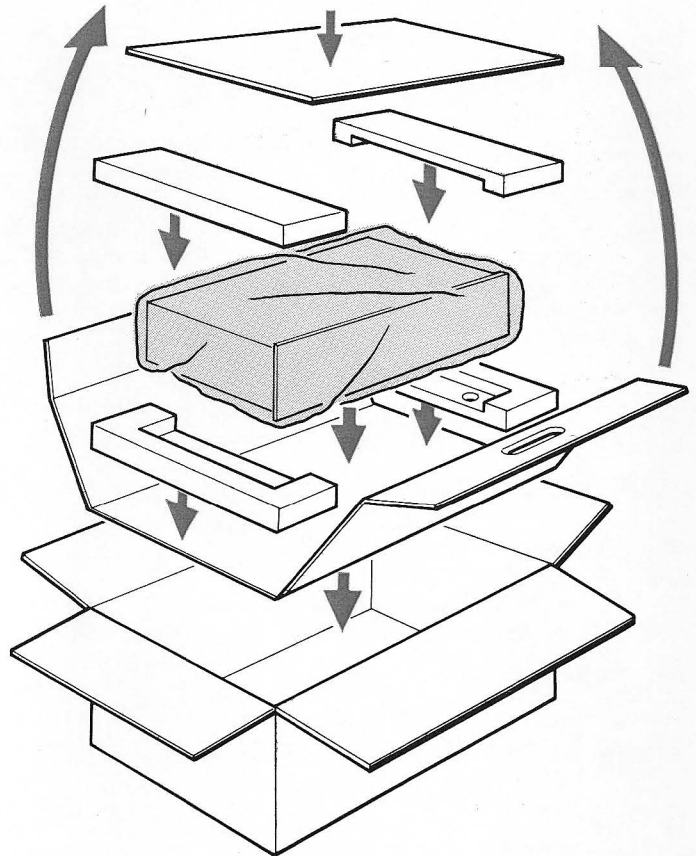

TECHNICAL DATA

TECHNICAL SPECIFICATIONS

Fm Tuner Section

Tuning range :	87.5 MHz - 108 MHz
Antenna terminals :	300 ohms balanced 75 ohms unbalanced
Intermediate frequency :	10.7 MHz
Sensitivity :	1.5 μ V, IHF 1.2 μ V, S/N=30 dB
Image rejection :	100 dB
I-f rejection :	100 dB
Spurious rejection :	100 dB
A-m suppression :	60 dB
Capture ratio :	1 dB
Selectivity :	100 dB
Signal-to-noise ratio :	75 dB
Frequency response :	20 Hz - 15 kHz \pm 1 dB
Harmonic distortion :	Mono 0.2% Stereo 0.3% at 400 Hz, 100% modulation
Stereo separation :	42 dB at 400 Hz
19 kHz, 38 kHz suppression :	60 dB
SCA suppression :	55 dB
Muting level :	Less than 5 μ V

A-m Tuner Section

Tuning range :	530 kHz - 1,605 kHz
Antenna :	Built-in ferrite bar antenna and external antenna terminal
Intermediate frequency :	455 kHz
Sensitivity :	50 dB/m, built-in antenna 20 μ V, external antenna
Signal-to-noise ratio :	50 dB
Image rejection :	45 dB at 1,000 kHz
I-f rejection :	41 dB at 1,000 kHz
Harmonic distortion :	0.6%

General

Outputs :	FIXED 750 mV, 10 kohm impedance VARIABLE 0-2 volts, 1.8 kohm impedance MULTIPATH (VERTICAL/HORIZONTAL) 150 mV, 18 kohm impedance
System :	Fm stereo, fm/a-m superheterodyne
Semiconductors :	4 FET+22 transistors for reception 5 FET+26 transistors for auxiliary circuits 41 diodes
Power requirements :	120 volts, 50 Hz/60 Hz ac
Power consumption :	25 watts
Dimensions :	15 $\frac{3}{4}$ (w) \times 5 $\frac{7}{8}$ (h) \times 13 $\frac{3}{16}$ (d) inches
Weight :	16 lb 8 oz (net) 22 lb 4 oz (in shipping carton)
Supplied accessories :	Fm ribbon antenna (1) Connecting cord RK-74 (1) Polishing cloth (1) 75-ohm cable connector (1)

Design and specifications subject to change without notice.

BLOCK DIAGRAM

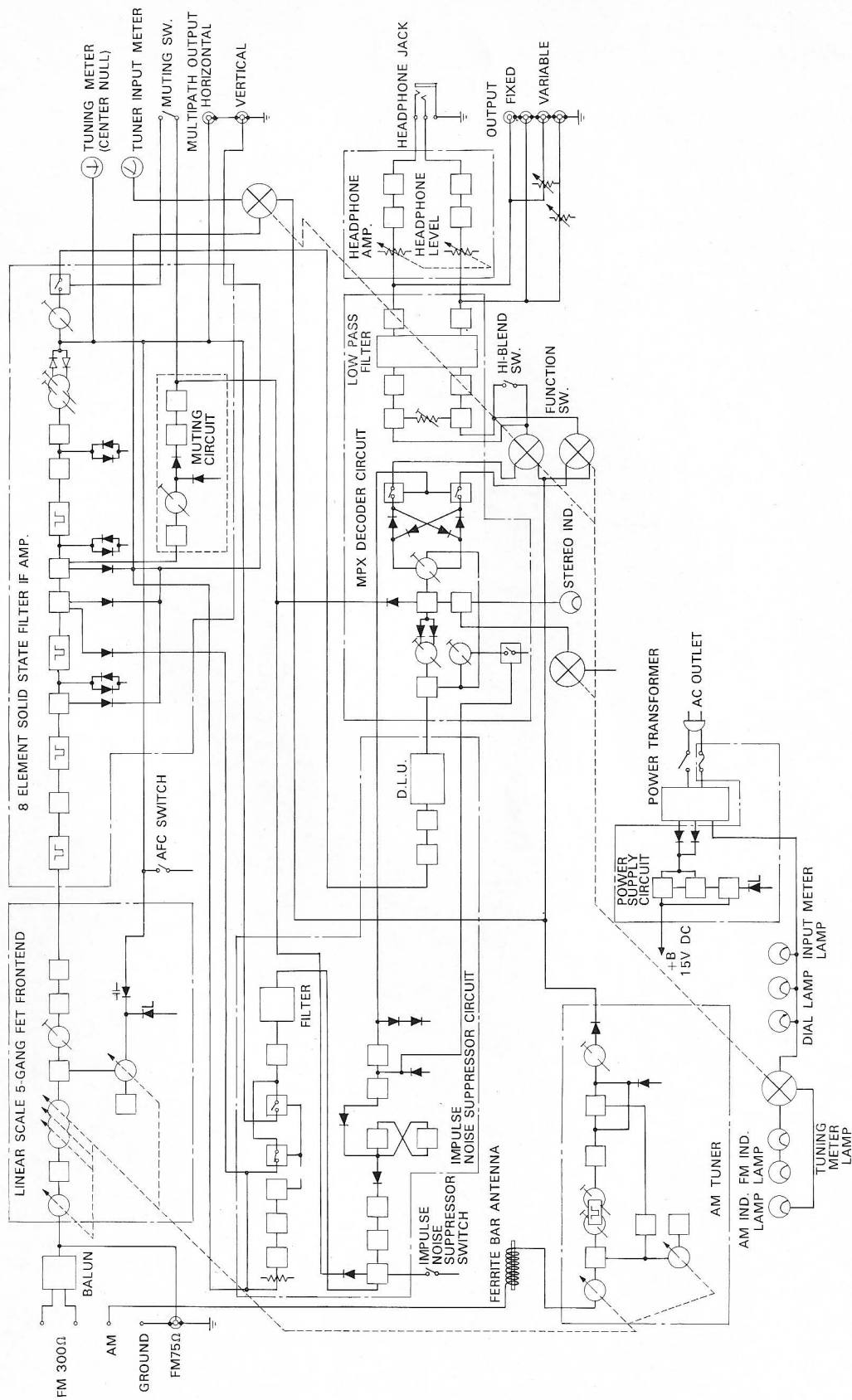

OPERATING CURVES

Output Signal and Noise Level vs. Input Signal Level Distortion vs. Input Signal Level

Carrier frequency: 98 MHz

Antenna terminal: 300-ohms

Modulation: 400 Hz, 100% (75 kHz dev.)

At fixed output terminal (load impedance 100 k-ohms)

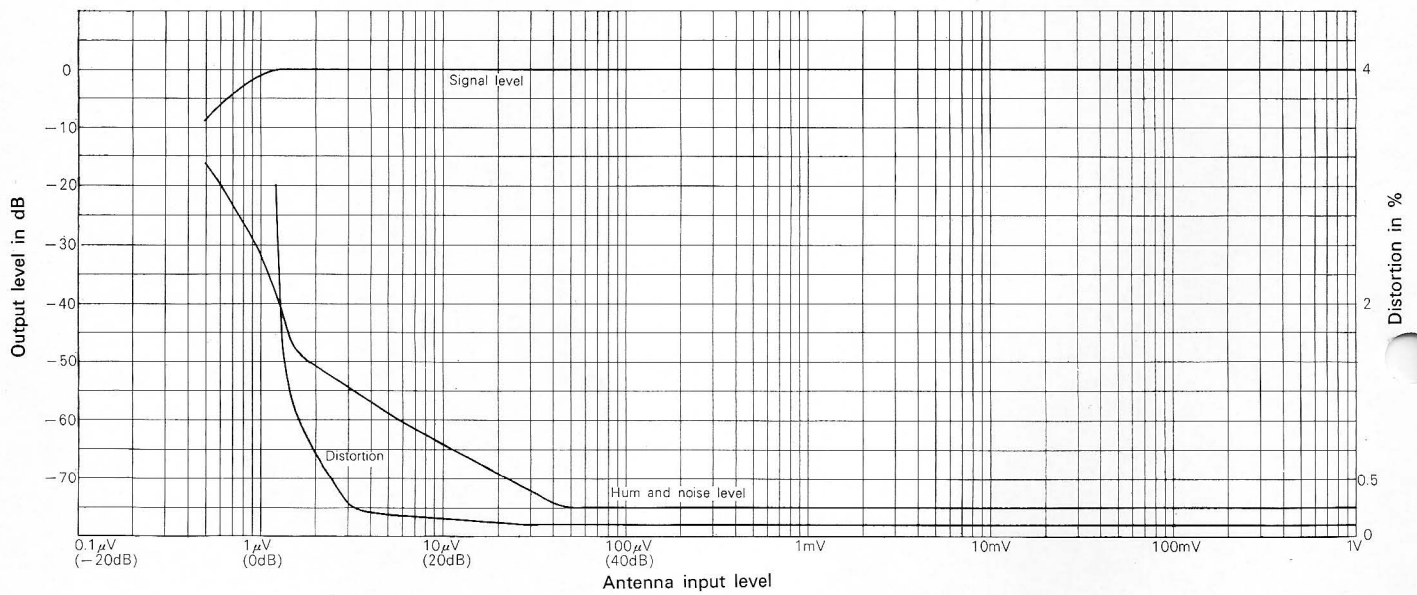

Frequency Response (Stereo)

Separation vs. Frequency Characteristic

Carrier frequency: 98 MHz
Antenna input: 1 mV
Modulation: Main channel 45% (33.75 kHz)
Sub channel 45% (33.75 kHz)
Pilot 10% (7.5 kHz)

At fixed output terminal (load impedance 100 k-ohms)

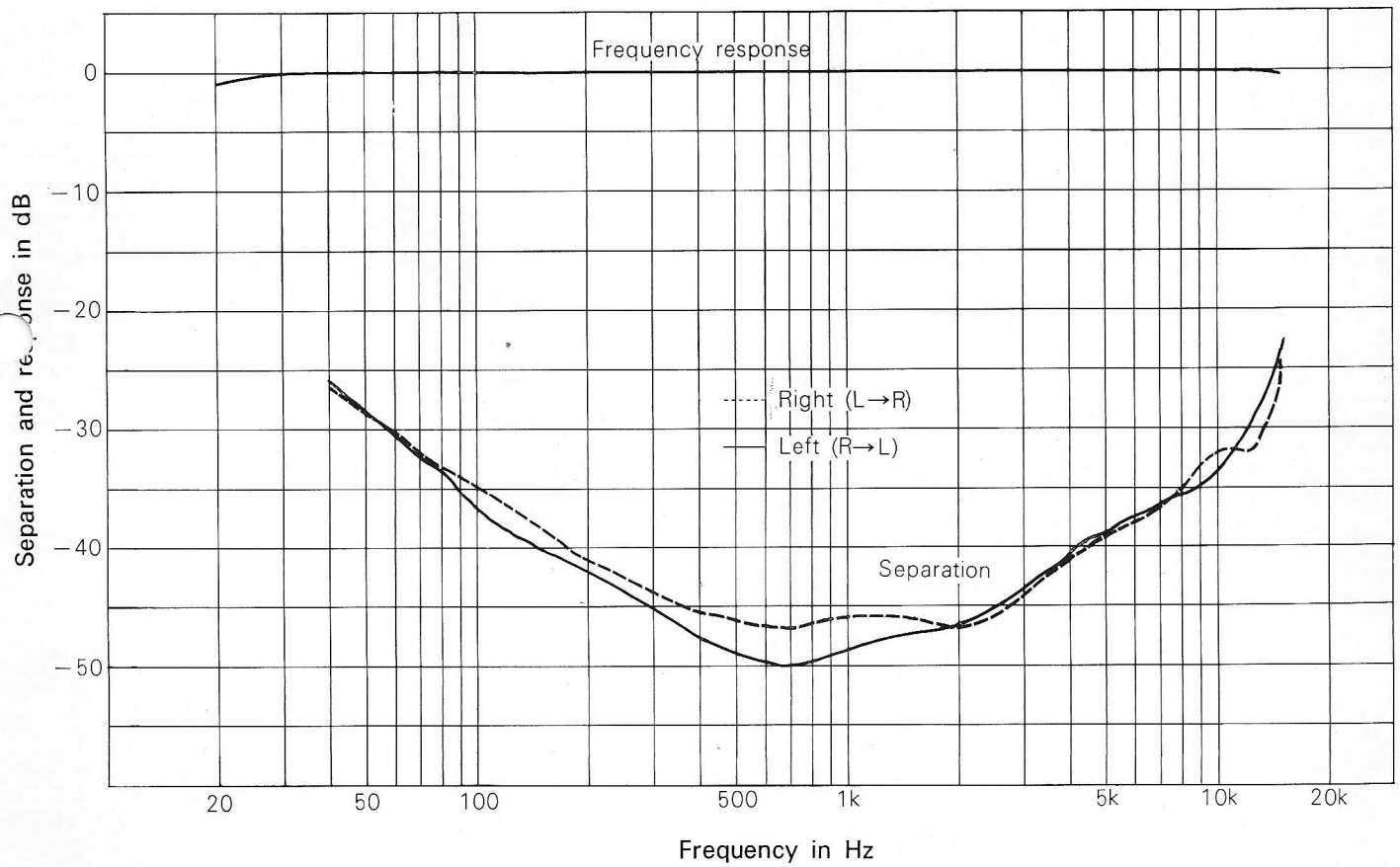

Distortion vs. Frequency Response (Mono and Stereo)

Carrier frequency: 98 MHz
Antenna input: 1 mV
Modulation: STEREO
Main channel 45% (33.75 kHz)
Sub channel 45% (33.75 kHz)
Pilot 10% (7.5 kHz)
MONO
100% (75 kHz)
At fixed output terminal (load impedance 100 k-ohms)

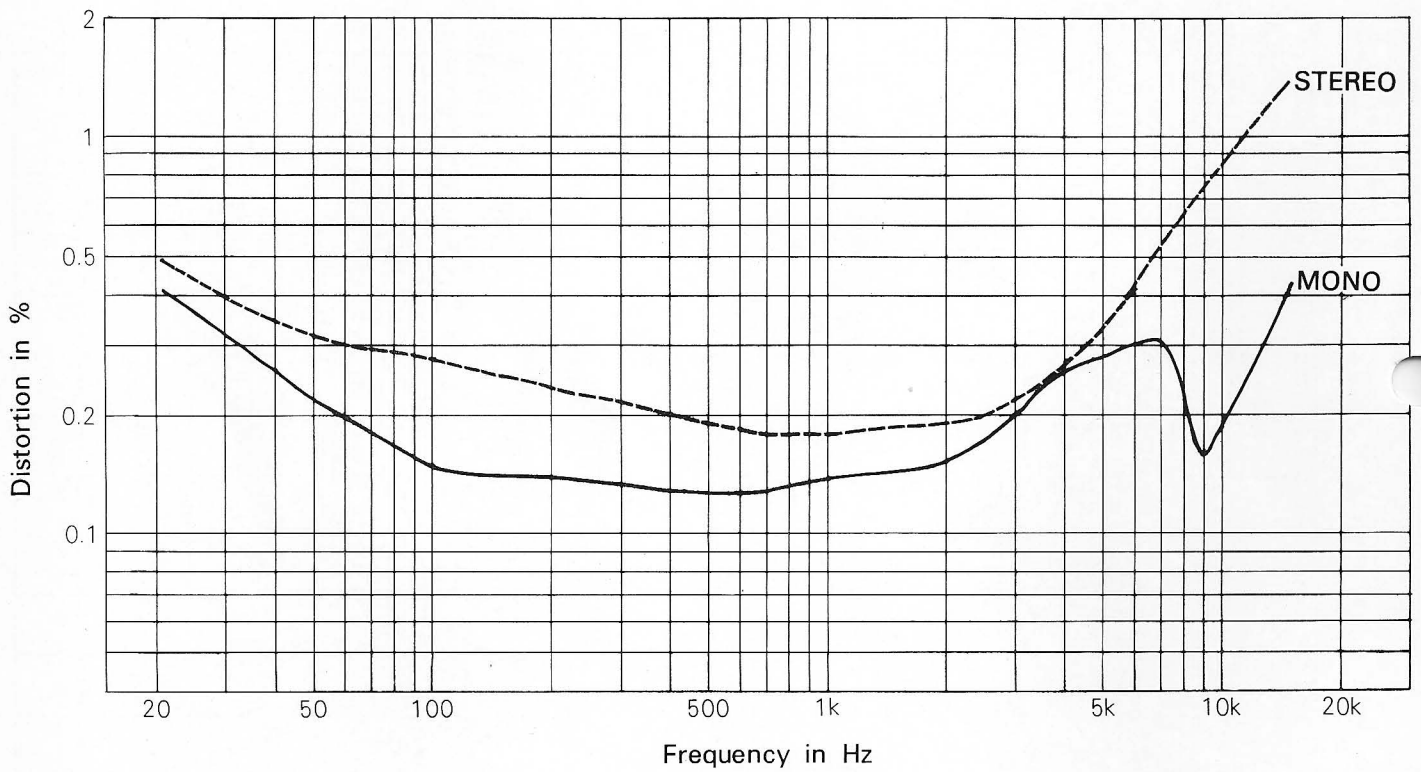

Selectivity

Carrier frequency : 98 MHz
Modulation of interference signal : 400 Hz
Desired signal to interference signal ratio : -30 dB

