

Service Manual

Nakamichi Cassette Deck



CONTENTS

1. General	1
2. Removal Procedures	3
2. 1. Top Cover Ass'y	3
2. 2. Cassette Case Cover Ass'y	3
2. 3. Mechanism Ass'y	3
2. 4. Front Panel Ass'y	3
2. 5. Main P.C.B. Ass'y	4
2. 6. Power Supply & Logic P.C.B. Ass'y	4
2. 7. Control Switch & Display P.C.B. Ass'y	4
3. Test Tapes and Gauges	5
4. Mechanical Adjustments	5
4. 1. Tape Guide Height Check for Record/Playback Head and Erase Head	5
4. 2. Head Base Stroke Check	5
4. 3. Record/Playback Head Azimuth Alignment and Height Check	5
4. 4. Pressure Adjustment of Pressure Roller	6
4. 5. Tape Travelling Check	6
4. 6. Eject Damper Adjustment	6
4. 7. Reel Motor Speed Adjustment in Play Mode	6
4. 8. Tape Speed Adjustment	6
4. 9. Lubrication	6
5. Parts Location for Electrical Adjustment	7
6. Electrical Adjustments	8
7. Mechanism Ass'y and Parts List	11
7. 1. Synthesis	11
7. 2. Front Panel Ass'y (A01)	12
7. 3. Front Chassis Ass'y (A02)	12
7. 4. Chassis Ass'y (A03)	13
7. 5. Mechanism Ass'y (A04)	14
8. Mounting Diagrams and Parts List	15
8. 1. Main P.C.B. Ass'y	15
8. 2. Power Supply & Logic P.C.B. Ass'y	17
8. 3. Timer Switch P.C.B. Ass'y	18
8. 4. Headphone P.C.B. Ass'y	18
8. 5. Pin Jack P.C.B. Ass'y	19
8. 6. Shut-off P.C.B. Ass'y	19
8. 7. Control Switch & Display P.C.B. Ass'y	19
9. Schematic Diagrams	20
9. 1. IC Block Diagrams	20
9. 2. Schematic Diagrams	23
10. Wiring Diagram	25
11. Block Diagrams	26
11. 1. Amplifier Section	26
11. 2. Mechanism Control Section	27
12. Timing Charts and Eq. Amp. Frequency Response	28
12. 1. Timing Charts	28
12. 2. Eq. Amp. Frequency Response	29
13. Specifications	30

1. GENERAL

1.1. Production No.
Production No.: A327

1.2. Destinations
USA, CAN, EP, UK, AUS, SAU, OTR, JPN

Abbreviation

USA - U.S.A.	AUS - Australia
CAN - Canada	SAU - Saudi Arabia
EP - Europe	OTR - Other
UK - United Kingdom	JPN - Japan

1.3. Parts Supply

(1) Unstocked Parts
Parts marked with "★" at the head of part No. are not stocked. So, it takes time to supply the parts after we receive your order.

(2) Unsupplied Parts

Parts without part Nos. (indicated as "—" in the parts list) are not supplied.

1.4. CAUTIONS/WARNINGS

(1) Product Safety Notice

Parts marked with the symbol  in the schematic diagram have critical characteristics.

Use ONLY replacement parts recommended by the manufacturer.

It is recommended that the unit be operated from a suitable DC supply or batteries during initial check-out procedures.

(2) Leakage Current Check/Resistance Check

Before returning the unit to the customer, make sure you make either (1) a leakage current check or (2) a line to chassis resistance check. If the leakage current exceeds 0.5

milliamp, or if the resistance from chassis to either side of the power cord is less than 240 k ohms, the unit is defective.

WARNING — DO NOT return the unit to the customer until the problem is located and corrected.

1.5. Voltage Selector

Voltage selector is installed on the Rear Panel of the Nakamichi Cassette Deck 2 (Other & Saudi Arabia). The voltage selector can select either 110 V/127 V or 220 V/240 V at customer's disposal.

1.6. Package Ass'y and Accessory Ass'y

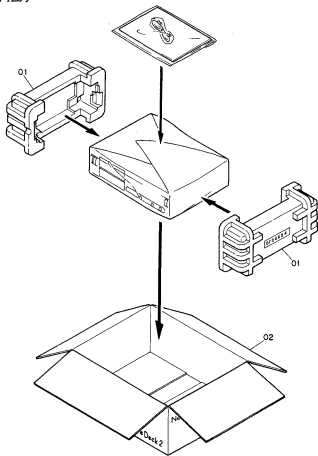

Fig. 1

Schematic Ref. No.	Part No.	Description	Q'ty	Schematic Ref. No.	Part No.	Description	Q'ty
01	0F04434A	Package Ass'y	2	DA04397A	Accessory Ass'y (USA, CAN)	1	
	DA04399A			Accessory Ass'y (EP)	1		
02	0F04456A	Packing Carton Box	1	DA04406A	Accessory Ass'y (UK)	1	
	DA04398A			Accessory Ass'y (AUS, SAU, OTR)	1		
				DA04396A	Accessory Ass'y (JPN)	1	
				OD06116A	Owner's Manual (English/French/Germany)	1	
				OD06115A	Owner's Manual (Japanese)	1	
				DA04388A	Pin-Pin Cord Ass'y	2	

2. REMOVAL PROCEDURES

2.1. Top Cover Ass'y

Refer to Fig. 2.1.

- (1) Loosen screws F01 (2 pcs.) and F02 (4 pcs.), and remove F03 (Top Cover Ass'y).

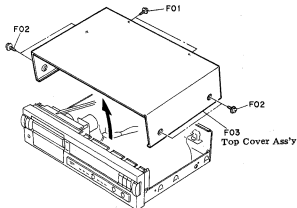

Fig. 2.1

2.2. Cassette Case Cover Ass'y

Refer to Fig. 2.2.

- (1) Press the Eject Knob Ass'y to open F01 (Cassette Case Cover Ass'y).
- (2) Pull F01 (Cassette Case Cover Ass'y) upward.

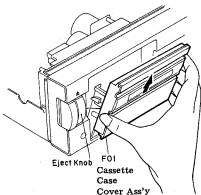

Fig. 2.2

2.3. Mechanism Ass'y

Refer to Fig. 2.3.

- (1) Remove the Top Cover Ass'y referring to item 2.1.
- (2) Remove the Cassette Case Cover Ass'y referring to item 2.2.
- (3) Loosen screws F01 (3 pcs.) and F02 (1 pc.).
- (4) Disconnect connectors (CN-4, CN-5, CN-6, CN-14 and CN-15).
- (5) Remove F03 (Mechanism Ass'y) in the direction of the arrow.

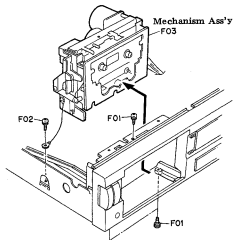

Fig. 2.3

2.4. Front Panel Ass'y

Refer to Figs. 2.4.1 and 2.4.2.

- (1) Remove the Top Cover Ass'y referring to item 2.1.
- (2) Loosen screws F03 (2 pcs.), F02 (1 pc.) and F03 (2 pcs.). See Fig. 2.4.1.
- (3) Press claws A (3 pcs.) downward to unhook them.
- (4) Disconnect a connector (CN-9) and remove F04 (Front Panel Ass'y). See Fig. 2.4.2.

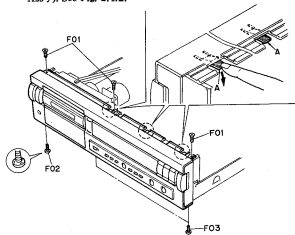

Fig. 2.4.1

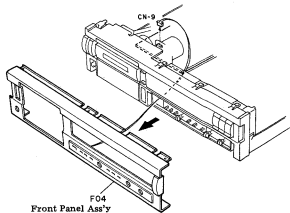

Fig. 2.4.2

2.5. Main P.C.B. Ass'y

Refer to FIG. 2.5.1 and 2.5.2.

- (1) Remove the Front Panel Ass'y referring to item 2.4.
- (2) Loosen screws F01 (4 pcs.), F02 (1 pc.) and F03 (2 pcs.). See Fig. 2.5.1.
- (3) Slide out F04 (Front Chassis Ass'y & Main P.C.B. Ass'y) forward.
- (4) Loosen screws F05 (2 pcs.) and F06 (2 pcs.), and remove F07 (Shield Plate). See Fig. 2.5.2.
- (5) Loosen screws F08 (2 pcs.) and remove F09 (Main P.C.B. Ass'y).

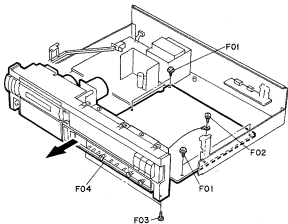

Fig. 2.5.1

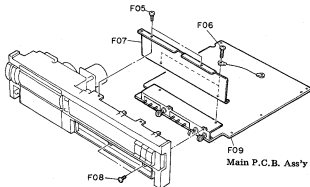

Fig. 2.5.2

2.6. Power Supply & Logic P.C.B. Ass'y

Refer to Fig. 2.6.

Caution: Unplug the power cord from the AC outlet.

- (1) Remove the Top Cover Ass'y referring to item 2.1.
- (2) Push F01 (Power Switch Joint) rearward (in the direction (A)).
- (3) Pull F01 (Power Switch Joint) forward (in the direction (B)) and lift it in the direction (C) to disengage F01 (Power Switch Joint) from the Power Switch.
- (4) Remove F01 (Power Switch Joint).
- (5) Loosen screws F02 (1 pc.), F03 (3 pcs.) and F04 (1 pc.), and remove F05 (Power Supply & Logic P.C.B. Ass'y).

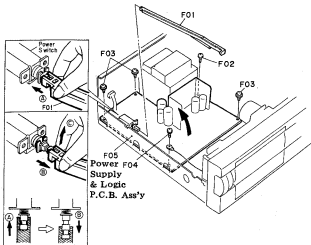

FIG. 2.6

2.7. Control Switch & Display P.C.B. Ass'y

Refer to Fig. 2.7.

- (1) Remove the Front Panel Ass'y referring to item 2.4.
- (2) Loosen screws F01 (2 pcs.) and F02 (2 pcs.), and remove F03 (Shield Plate).
- (3) Loosen screws F04 (2 pcs.), unhook claws (5 pcs.), and remove F05 (Control Switch & Display P.C.B. Ass'y).

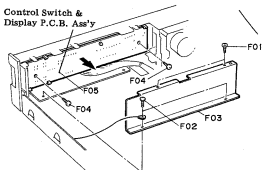

Fig. 2.7

3. TEST TAPES AND GAUGES

- (1) 400 Hz Level Tape (DA09005B)
- (2) 1 kHz Track Alignment Tape (DA09007B)
- (3) 10 kHz PB Frequency Response Tape (DA09003B)
- (4) 15 kHz PB Frequency Response Tape (DA09002B)
- (5) 20 kHz PB Frequency Response Tape (DA09001B)
- (6) 15 kHz Azimuth Tape (DA09004B)
- (7) 3 kHz Speed and Wow/Flutter Tape (DA09006C)
- (8) Tape Travelling Cassette (DA09071A)
- (9) Reference EXII Tape (DA09111A)
- (10) Reference SX Tape (DA09110A)
- (11) Reference ZX Tape (DA09109A)
- (12) Head Alignment Gauge (DA09092B)
- (13) Torque Gauge FWD (DA09082A)

4. MECHANICAL ADJUSTMENTS

4.1. Tape Guide Height Check for Record/Playback Head and Erase Head

With use of a Head Alignment Gauge (DA09092B), tape guide height check for the Record/Playback and Erase Heads shall be made, wherein a small block shall be pushed straight down to the base while in use of the Head Alignment Gauge (DA09092B). Refer to Fig. 4.1.

- (1) **Record/Playback Head Tape Guide Height**
 - (a) Load the base of the Head Alignment Gauge (DA09092B) carefully and set the cassette deck in Play mode.
 - (b) Place the small block of the Head Alignment Gauge (DA09092B) on the base.
 - (c) Slide the small block against the tape guide of the Record/Playback Head, and check to insure that the block is accepted by the tape guide.
 - (d) If not, loosen the screw and insert a shim (either 30 μm (OC80048A), 60 μm (OC80038A), or 100 μm (OC80039A)) to raise the Record/Playback Head, then tighten and apply a quantity of lock tight paint to the screw.
- (2) **Erase Head Tape Guide Height**
 - (a) Load the base of the Head Alignment Gauge (DA09092B) carefully and set the cassette deck in Play mode.
 - (b) Place the small block of the Head Alignment Gauge (DA09092B) on the base.
 - (c) Slide the small block against the tape guide of the Erase Head, and check whether the block is accepted by the tape guide.

4.2. Head Base Stroke Check

Refer to Fig. 4.2.

- (1) Load the base of the Head Alignment Gauge (DA09092B) carefully, then push the base toward the Record/Playback Head to eliminate the clearance between the reference pin and the base.
- (2) Set the cassette deck in Play mode.
- (3) Place the small block of the Head Alignment Gauge (DA09092B) on the base.
- (4) Contact the small block with the Record/Playback Head surface and the Erase Head surface, and check whether the end of the small block is located within the specified tolerance as shown in Fig. 4.2.

4.3. Record/Playback Head Azimuth Alignment and Height Check

Refer to Fig. 4.1.

- (1) Contact an AC voltmeter to the Output Jacks.
- (2) Load a 15 kHz Azimuth Tape (DA09004B) and set the cassette deck in Play mode.
- (3) Turn the Azimuth Alignment Screw until the outputs of both channels become maximum.
- (4) Load a 1 kHz Track Alignment Tape (DA09007B) and set the cassette deck in Play mode.
- (5) Check to insure that the readings of both channels on the AC voltmeter are below -25 dB.
If not, replacement of the Record/Playback Head will be required.
- (6) Apply a quantity of lock tight paint to the Azimuth Alignment Screw.

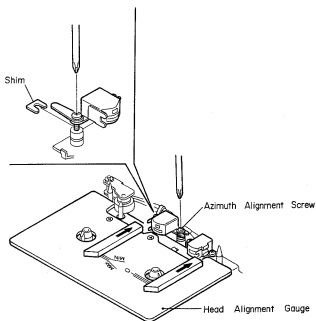

Fig. 4.1

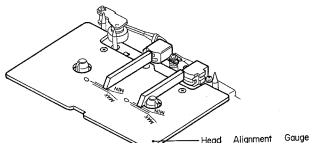

Fig. 4.2

4.4. Pressure Adjustment of Pressure Roller

Refer to Fig. 4.3.

- (1) In Play mode, measure the Pressure of the Pressure Roller against the capstan and check whether the pressure is in a range of 360 ± 40 g.
- (2) If pressure is out of the range, correct it by changing the installation point of the Pressure Roller Spring.

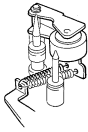

Fig. 4.3

4.5. Tape Travelling Check

Load a Tape Travelling Cassette (DA09071A) and set the cassette deck in Play mode to check the followings:

- (1) After more than 2 seconds, the fluctuation of the tape travelling on the Record/Playback Head is small.
- (2) Tape is in contact with the head sufficiently.
- (3) Tape waving is small on the heads and pressure roller.



Fig. 4.4

4.6. Eject Damper Adjustment

Refer to Fig. 4.5. Load a cassette tape, and with opening the Cassette Case by pressing the Eject button and closing it by hand, adjust the speed of damper action by the Damper Adjustment Screw.

- CCW: Damper moves fast.
CW: Damper moves slowly.

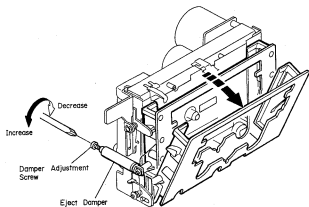

Fig. 4.5

4.7. Reel Motor Speed Adjustment in Play Mode

- (1) Load a Torque Gauge FWD (DA09082A) and set the cassette deck in Play mode.
- (2) After 5 to 10 seconds, adjust VR501 on the Power Supply & Logic P.C.B. Ass'y to obtain exactly 45 g-cm on the torque gauge.
- (3) Check that the back tension is in a range of 1.5 to 5 g-cm.

4.8. Tape Speed Adjustment

Refer to Fig. 4.6.

- (1) Connect a frequency counter to the Output Jacks.
- (2) Load a 3 kHz Speed and Wow/Flutter Tape (DA09006C) and play it back.
- (3) Adjust the Tape Speed Adjustment Volume incorporated in the Capstan Motor to obtain 3,000 Hz on the frequency counter.

- CCW: Motor drives slowly.
CW: Motor drives fast.

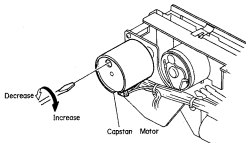

Fig. 4.6

4.9. Lubrication

The tape transport is of a lubrication-free type mechanism. When the following parts are replaced, apply the specified lubricant.

- (1) Molykote $\text{\textcircled{R}}$ Grease (X5-6020)
Cam Motor Pulley
Thrust portion on the Capstan Shaft
- (2) FLOIL GB-TS-1
Washer between Reel Hub Ass'y and Back Tension Spring
- (3) Diamond Oil (EP-56)
Reel Hub Shaft
- (4) Anderol 456
Capstan Shaft

Note: We suggest that you use the above specified lubricant or equivalent type.

The company dealing in the above lubricant is as follows:

- (a) Molykote $\text{\textcircled{R}}$ Grease (X5-6020)
Dowcorning Co., Ltd., 1-15-1 Nishishinbashi, Minato-ku, Tokyo, Japan
- (b) FLOIL GB-TS-1
Kanto Chemicals Co., Ltd., 2-7 Kanda Sakuma-cho, Chiyoda-ku, Tokyo, Japan
- (c) Diamond Oil (EP-56)
Mitsubishi Oil Co., Ltd., 1-2-4 Toranomon, Minato-ku, Tokyo, Japan
- (d) Anderol 456
Toyo Kokuasai Oil Co., Ltd., 3-3-5 Hatchobori, Chuo-ku, Tokyo, Japan

5. PARTS LOCATION FOR ELECTRICAL ADJUSTMENTS

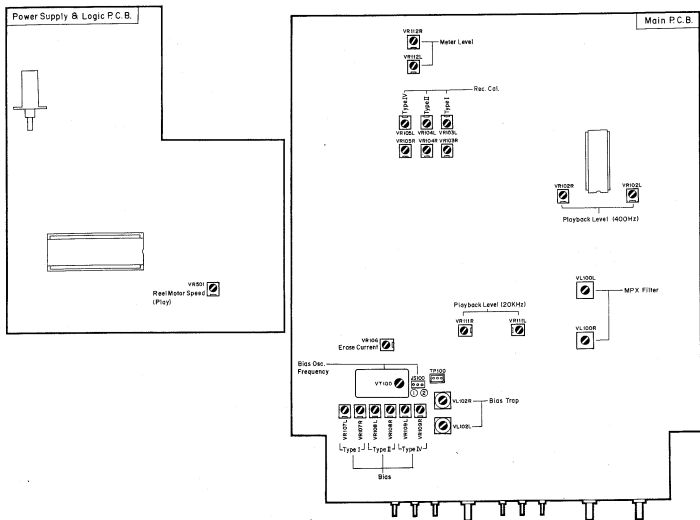
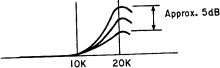
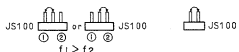

Fig. 5

6. ELECTRICAL ADJUSTMENTS

STEP	ITEM	SIGNAL SOURCE	OUTPUT CONNECTION	MODE	ADJUSTMENT	REMARKS
1	Preliminary Step			Balance - Center Bias Tune - Center Tape - Type IV MPX Filter - OFF Dolby NR - OFF		Set the Cassette Deck 2 as shown in MODE.
2	Reel Motor Speed Adjustment (Play)	Torque Gauge FWD (DA09082A)		Playback	Power Supply & Logic P.C.B. VR501	1. Play back a Torque Gauge FWD and adjust VR501 to obtain 45 g-cm on the torque gauge. 2. Check that the deviation of the torque value is within ± 5 g-cm of the center value.
3	Tape Speed Adjustment	3 kHz Speed and Wow/Flutter Tape (DA09006C)	Frequency Counter to Output Jacks	Playback Tape - Type IV	Tape Speed Adj. Volume (Capstan Motor)	Adjust the volume incorporated in the capstan motor to obtain 3 kHz ± 15 Hz on the frequency counter.
4	Meter Level Calibration	400 Hz to Input Jacks	AC Voltmeter to Output Jacks	Record, Pause	Main P.C.B. VR112L VR112R	1. Feed in 400 Hz and adjust the Rec Level control to obtain 500 mV -0.5 dB on the AC voltmeter. 2. Adjust VR112L (VR112R) so that the 0 dB segment of the level meter starts illuminating.
5	MPX Filter Adjustment	19 kHz ± 100 Hz to Input Jacks	AC Voltmeter to Output Jacks	Record, Pause MPX - OFF/ON	Main P.C.B. VL100L VL100R	1. Adjust the Rec Level control to obtain 500 mV (0 dB) on the AC voltmeter. 2. Set the MPX Filter switch to ON and adjust VL100L (VL100R) to obtain minimum reading on the AC voltmeter (minimum reading will be less than -30 dB).
6	Record/Playback Head Azimuth Alignment	15 kHz Azimuth Tape (DA09004B)	AC Voltmeter to Output Jacks	Playback Dolby NR - OFF MPX - OFF Tape - Type IV	Record/Playback Head Azimuth Alignment Screw	Adjust the Record/Playback Head Azimuth Alignment Screw to obtain maximum readings for both channels on the AC voltmeter.
7	Playback Level Calibration	400 Hz Level Tape (DA09005B)	AC Voltmeter to Output Jacks	Same as above	Main P.C.B. VR102L VR102R	Adjust VR102L (VR102R) to obtain 500 mV on the AC voltmeter.

STEP	ITEM	SIGNAL SOURCE	OUTPUT CONNECTION	MODE	ADJUSTMENT	REMARKS	
8	Playback Frequency Response Adjustment	400 Hz Level Tape (DA09005B) 10 kHz PB Frequency Response Tape (DA09003B) 15 kHz PB Frequency Response Tape (DA09002B) 20 kHz PB Frequency Response Tape (DA09001B)	AC Voltmeter to Output Jacks	Playback Dolby NR - OFF MPX - OFF Tape - Type IV	Main P.C.B. VR111L VR111R	<ol style="list-style-type: none"> Load a 400 Hz level tape, play it back, and read the playback level. Load 10 kHz, 15 kHz and 20 kHz PB frequency response tapes and play them back. Adjust the record/playback head azimuth to obtain maximum readings for both channels on the AC voltmeter with each tape. Check that the playback levels are as follows with respect to the level for 400 Hz level tape. 10 kHz: -20 dB -2 to +2 dB 15 kHz: -20 dB -2 to +3 dB 20 kHz: -20 dB -2 to +4 dB If the level at 20 kHz is out of the range, adjust VR111L (VR111R) to obtain satisfactory results. VR111L (VR111R) compensates the playback frequency response at 20 kHz as shown below:  Conduct step 6 "Record/Playback Head Azimuth Alignment". 	
9	Bias Oscillation Frequency and Erase Current Adjustment	None	Frequency Counter between terminals 1 and 2 of CN15 on Main P.C.B. and AC Voltmeter across the additional 0.1 ohm resistor	Record, Pause Tape - Type I Dolby NR - OFF MPX - OFF	Main P.C.B. VT100 JS100 VR106	<ol style="list-style-type: none"> Connect an additional 0.1 ohm resistor in series to the Erase Head and connect the AC voltmeter across it. Adjust VT100 to obtain 105 kHz \pm1 kHz on the frequency counter. If bias oscillation frequency is above 106 kHz, short-circuit JS100 with a jumper wire as shown left and re-adjust VT100 again. Adjust VR106 to obtain 20 mV (200 mA) on the AC voltmeter. After completion of the erase current adjustment, re-check the bias oscillation frequency. Remove the additional 0.1 ohm resistor. 	
		[Serial No.: A32705801] [Serial Nos.: A32701001-05800] 					
10	Bias Trap Adjustment (Record Amp.)	None (remove input signals)	AC Voltmeter between pins 1 (Lch) and 2 (GND) or 3 (Rch) and 2 (GND) of TP100 on Main P.C.B.	Same as above	Main P.C.B. VL102L VL102R	Adjust VL102L (VL102R) to obtain minimum reading on the AC voltmeter.	

STEP	ITEM	SIGNAL SOURCE	OUTPUT CONNECTION	MODE	ADJUSTMENT	REMARKS
11	Record Level Calibration and Recording Bias Current Adjustment	400 Hz (0 dB) 18 kHz (-20 dB) to Input Jacks	AC Voltmeter and Distortion Meter to Output Jacks	Record and Playback Tape - Type IV/II/ I Dolby NR - OFF/C MPX - OFF	Main P.C.E. (Level) Type IV VR105L VR105R Type II VR104L VR104R Type I VR103L VR103R (Bias) Type IV VR109L VR109R Type II VR108L VR108R Type I VR107L VR107R	Adjustment should be made in the order of ZX, SX and EX tapes. 1. Set the cassette deck in Record/Pause mode. 2. Feed in 400 Hz and adjust the Rec Level control to obtain 500 mV (0 dB) on the AC voltmeter. 3. Load a reference ZX tape, reference SX tape and reference EXII tape. 4. Set the Dolby NR switch to OFF. 5. Feed in 400 Hz (0 dB) and record, rewind, and play it back. Adjust VR105L (VR105R) for ZX tape, VR104L (VR104R) for SX tape and VR103L (VR103R) for EXII tape so that the played back output levels are 500 mV (0 dB) on the AC voltmeter. 6. Set the Dolby NR switch to C. 7. Feed in 18 kHz (-20 dB) and record, rewind, and play it back. Adjust VR109L (VR109R) for ZX tape, VR108L (VR108R) for SX tape and VR107L (VR107R) for EXII tape so that the played back output levels are 50 mV (-20 dB) on the AC voltmeter. 8. Repeat above 4 to 8 two or three times. 9. Set the Dolby NR switch to OFF. 10. Feed in 400 Hz (0 dB) and record, rewind, and play it back. Check to insure that the total harmonic distortion is less than 1.2% for ZX and EXII tapes and 1.6% for SX tape. If the total harmonic distortion exceeds the specified value, re-adjust VR111L (VR111R) in Step 8 "Playback Frequency Response Adjustment", and repeat above steps till satisfactory results are obtained.

7. MECHANISM ASS'Y AND PARTS LIST

7.1. Synthesis

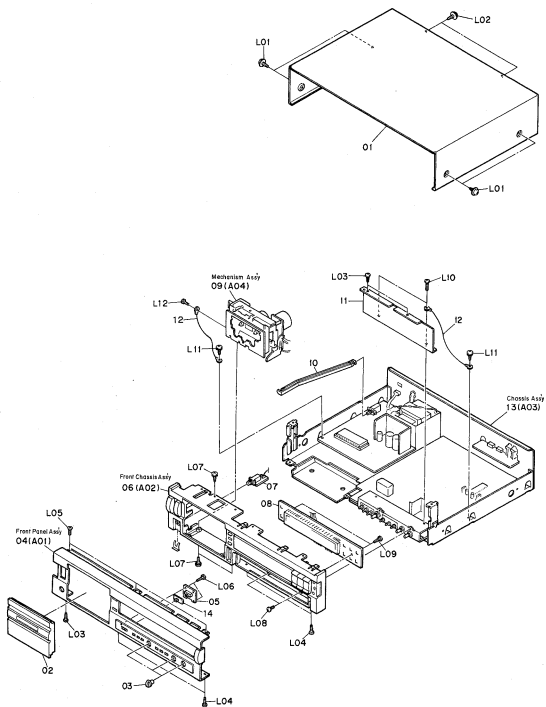

Fig. 7.1

*: Unstocked parts.

Schematic Ref. No.	Part No.	Description	Q'ty
7.1. Synthesis			
		Synthesis	
01	OH05710A	Top Cover	1
02	* HA05930A	Cassette Case Cover Ass'y	1
03	OH05711A	Volume Knob	3
04	* HA05930A	Front Panel Ass'y	1
05	* BA07947A	Timer Switch P.C.B. Ass'y	1
06	—	Front Chassis Ass'y	1
07	* BA07960A	Headphone P.C.B. Ass'y	1
08	* BA07945A	Control Switch & Display P.C.B. Ass'y	1
09	* CA09049A	Mechanism Ass'y	1
10	OJ06258A	Power Switch Joint	1
11	OJ06259A	Shield Plate	1
12	OB83916A	Mechanism GND Wire Ass'y	2
13	—	Chassis Ass'y	1
14	OH05824A	Slide Knob	1
L01	OE03032A	BT4x8 @ Binding Washer Faced (Black Chromate)	1
L02	OE03632A	BT3x8 @ Binding Washer Faced (Black Chromate)	1
L03	OE03366A	BT3x8 @ Binding (Black Chromate)	1
L04	OE00921A	BT3x8 @ Binding (Black Chromate)	1
L05	OE03054A	BT3x8 @ Countersunk	1
L06	OE00860A	BT3x6 @ Binding	1
L07	OE03212A	BT2.6x6 @ Binding with Toothed Lock Washer	1
L08	OE00896A	M3x6 @ Binding	1
L09	OE00868A	BT3x8 @ Binding (Black Chromate)	1
L10	OE03551A	M3x8 @ Binding Projected	1
L11	OE03157A	BT3x6 @ Binding with Washer	1
L12	OE00859A	BT2.6x6 @ Binding	1
7.2. Front Panel Ass'y			
A01	HA05930A	Front Panel Ass'y	1
01	OH05714A	Dummy Cap	1
02	OJ06253A	Push Knob Spring	6
03	OH05815A	Push Knob	6
L01	OE00855A	BT2x6 @ Binding	1
7.3. Front Chassis Ass'y			
A02	—	Front Chassis Ass'y	1
01	OH05723A	Power Switch Button	1
02	OC09382A	Power Switch Spring	1
03	HA05929A	Eject Knob Ass'y	1
04	OJ06252A	Eject Spring	1
05	OH05716A	Control Knob A	3
06	OH05825A	Tact Knob	2

7.2. Front Panel Ass'y (A01)

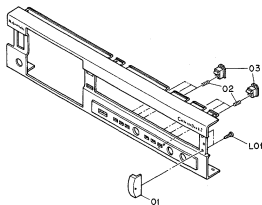

Fig. 7.2

7.3. Front Chassis Ass'y (A02)

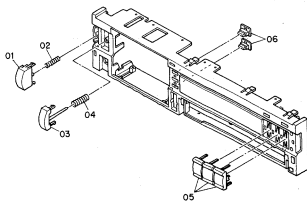

Fig. 7.3

7.4. Chassis Ass'y (A03)

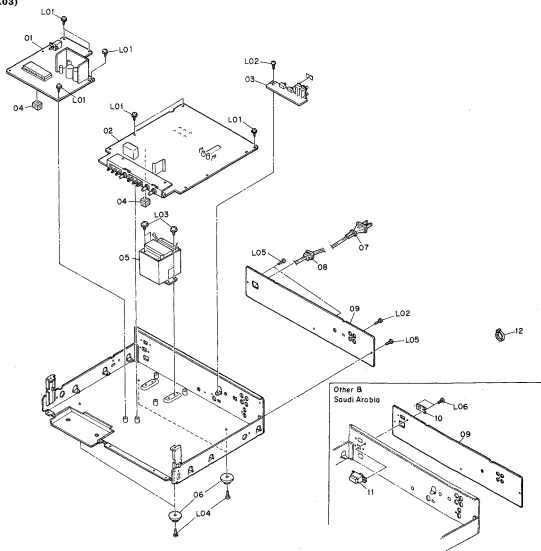

Fig. 7.4

*: Unstocked parts.

Schematic Ref. No.	Part No.	Description	Q'ty	Schematic Ref. No.	Part No.	Description	Q'ty
7.4. Chassis Ass'y							
A03	—	Chassis Ass'y	1	08	0B90280A	Cord Bushing (USA, CAN, EP, AUS)	1
01 *	BA07944A	Power Supply & Logic P.C.B. Ass'y (USA, CAN, EP, UK, AUS, SAU, OTR)	1		0B90283A	Cord Bushing (UK, SAU, OTR, JPN)	1
01 *	BA07961A	Power Supply & Logic P.C.B. Ass'y (JPN)	1	09	0H05830A	Rear Panel (USA, CAN, EP, UK, AUS, JPN)	1
02 *	BA07959A	Main P.C.B. Ass'y	1	10	0H05847A	Rear Panel (SAU, OTR)	1
03 *	BA07946A	Pin Jack P.C.B. Ass'y	1	11	0M05611A	Voltage Lock Plate (OTR, SAU)	1
04	0J06267A	P.C.B. Cushion	5		0B07092U	Voltage Selector Switch (SAU, OTR)	1
05	0B50176A	Power Transformer 120V (USA, CAN)	1		0B90019A	Insu-Lock	2
	0B50178A	Power Transformer 230V (EP, UK, AUS)	1	L01	0E03157A	BT3x8 @ Binding With Washer	
	0B50177A	Power Transformer (SAU, OTR)	1	L02	0E03366A	BT3x8 @ Binding Projected (Black Chromate)	
	0B50175A	Power Transformer 100V (JPN)	1	L03	0E03592A	BT 4x6 @ Binding Washer Face (Black Chromate)	
06	HA05833A	Leg Ass'y	4	L04	0E03012A	BT3x12 @ Binding (Black Chromate)	
07	0B08504A	Power Cord (USA, CAN)	1	L05	0E00860A	BT3x6 @ Binding (Black Chromate)	
	0B08093U	Power Cord (EP)	1	L06	0E00985A	M3x6 @ Binding (Black Chromate) (SAU, OTR)	
	0B08348A	Power Cord (UK)	1				
	0B08241A	Power Cord (AUS)	1				
	0B08219B	Power Cord (JPN)	1				
	0B08533A	Power Cord (SAU, OTR)	1				

*: Unstocked parts.

Schematic Ref. No.	Part No.	Description	Qty
7.5. Mechanism Assy			
A04	CA09049A	Mechanism Assy	1
01	OC85310A	Eject Arm Spring	1
02	OC85309A	Eject Arm	1
03	CA80006A	Damper Assy	1
04	OC82720A	Eject Lever Spring	1
05	OC85414A	Eject Lever A	1
06	OC85301A	Cassette Case Holder L	4
07	OC80037A	Truss-Link	1
08	OC80019B	Eject Spring	1
09	OC80013A	Lock Lever Spring	1
10	OC80014A	Lock Lever Collar	1
11	OC82719A	Lock Lever B	1
12	CA80025A	Take-up Reel Hub Assy	1
13	OC80612A	Spring Holder	2
14	OC80613A	Reel Hub Spring	1
15	CA80001A	Cassette Case Assy	1
16	HA05936A	Cover Flap Assy	1
17	OG01525A	Erase Head E2D	1
18	OC85303A	2P Connector Assy for Erase Head	1
19	OC80044A	Erase Head Collar	1
20	OC82710A	Head Base Hold Plate	2
21	OC80004A	Steel Ball 3mm	1
22	OC80005A	Reinforce Plate	1
23	OG01371A	Record/Playback Head 2G	1
24	OC85304A	6P Connector Assy for R/P Head	1
25	OC80045A	Record/Playback Head Collar	1
26	OC82703A	Arithmetic Adjust Spring	1
27	OC82697A	Head Base B	1
28	CA80026A	Supply Reel Hub Assy	1
29	CA80005A	Pressure Roller Assy	1
30	OC80006A	Pressure Roller Spring	1
31	OC80007A	Steel Ball 2mm	3
32	OC80009A	Cassette Case Spring	1
33	CA81646A	Control Motor Assy	1
34	OC89027A	Mode Switch	1
35	OC81415A	Worm Thrust Bush	1
36	OC85302A	Control Motor Holder	1
37	OC85312A	Motor Thrust Stopper	1
38	OC81417A	Can	1
39	OC80017B	Record Protector Lever	1
40	OC82721A	Mechanism Chassis B	1
41	OC82709A	Cassette Holder Spring	1
42	OC80025A	Record Protector Holder	1
43	OC80024A	Record Protector Switch	1
44	CA80011B	Shut-off P.C.B. Assy	1
45	CA80204A	Brake Assy B	1
46	OC80628A	Brake Spring B	1
47	OC80030A	Reel Motor Holder	1
48	CA81648A	Reel Motor Assy	1
49	OC80031A	Capstan Flange	1
50	OC80428A	Hold Spring	1
51	OC80033A	Flywheel	1
52	OC80034A	Capstan Belt	3
53	OC80035A	Sleeve	3
54	OC80036A	Floating Rubber	1
55	CA80009A	Flywheel Holder Assy	1
56	CA81647A	Capstan Motor Assy	1
57	OC80010D	Cassette Case Holder R	1
58	OC80012A	Eject Sensor Switch	1
59	OC85305A	6P Connector Assy	1
60	OC85306A	6P Connector Assy	1
61	OC83890A	Idler Gear	1
L01	OE00698A	E-Ring 2.5mm	1
L02	OE03052A	CS Stopper 2.4mm	1
L03	OE03235A	Damper Washer	1
L04	OE00181A	E-Ring 3mm	1
L05	OE03042A	FT2.5x3.5 @ Pan	1
L06	OE03043A	FT2.5x10 @ Pan	1
L07	OE03437A	FT2.5x3.5 @ Pan	1
L08	OE03049A	Washer 1.8x3.2x0.5	1
L09	OE03226A	Washer 2.1x4.5x0.1	1
L10	OE03038A	M2x12 @ Binding	1
L11	OE03036A	FTx6	1
L12	OE03055A	Wim Holder	1
L13	OC80038A	Shim 0.06T	1
L14	OC80039A	Shim 0.1T	1
L15	OC80048A	Shim 0.03T	1
L16	OE03046A	M2x6 @ Pan (2A)	1
L17	OE03040A	FT2.5x3.5 @ Pan	1
L18	OE0222A	E-Ring 2mm	1
L19	OE03055A	M2x3.2 @ Truss	1
L20	OE03036A	M2x4 @ Pan (2A)	1
L21	OE03044A	FT2.5x20 @ Pan	1
L22	OE00691A	M2x8 @ Pan	1
L23	OE03048A	FT2.6x6 @ Pan	1
L24	OE03041A	FT2.6x4 @ Pan	1

7.5. Mechanism Assy (A04)

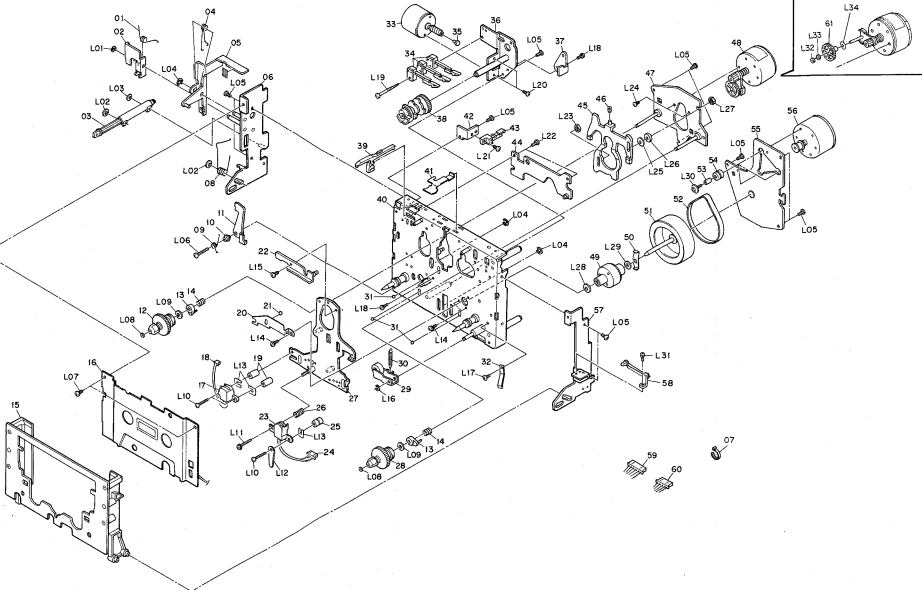

Fig. 7.5

Schematic Ref. No.	Part No.	Description	Qty
L23	OE03237A	Nut Hex. M2.6	1
L24	OE03045A	M2.6x3 @ Binding	1
L25	OC85411A	Brake Washer B	1
L26	OC85410A	Brake Washer A	1
L27	OE00694A	Nut Hex. M2	1
L28	OE03051A	Washer 2.5x7x0.8	1
L29	OE03245A	Plastic Washer 1.8x3.8x0.3	1
L30	OE03047A	M2x6 @ Pan	1
L31	OE03037A	M2x5 @ Pan (2A)	1
L32	OE03039A	Washer 1.8x3.4x0.3	1
L33	OE03658A	Washer 1.6x4x0.25	1
L34	OE03058A	Washer 1.7x6x0.25	1

8. MOUNTING DIAGRAMS AND PARTS LIST

Notes:

- Mounting diagram shows a dip side view of the printed circuit board.
- Diode is 1SS53, 1S1555, or 1SS176 unless otherwise specified.
- Abbreviation for part name:
 TR - Transistor, SID - Silicon Diode,
 ZD - Zener Diode, Varicap - Variable Capacitance Diode
 RK - Carbon Resistor, RM - Metal Film Resistor, RF - Fail Safe Type Resistor,
 RC - Cement Resistor
 CE - Electrolytic Capacitor, CML - Mylar Capacitor, CC - Ceramic Capacitor, CPP - PP Capacitor, CMM - Metalized Mylar Capacitor,
 CSP - Polystyrene Capacitor, C - Mica Capacitor, CT - Tantalum Capacitor

• Semiconductor Location

Ref. No.	Location	Ref. No.	Location
U100	C-5	Q115L	E-4
U101	C-9	Q115R	F-4
U102	F-9	Q116L	E-6
U103	I-9	Q116R	F-6
U104	H-6	Q117	E-2
U105	F-11	Q118L	C-11
U106	H-11	Q118R	C-11
Q100L	D-5	Q120	I-9
Q100R	D-5	Q121L	E-6
Q101L	D-6	Q121R	F-6
Q101R	D-5	ZD100	C-7
Q102L	F-10	ZD101	D-7
Q102R	F-8	ZD102	F-6
Q103	H-8	ZD103L	H-11
Q104	G-7	ZD103R	H-11
Q105L	I-7	ZD104L	I-11
Q105R	G-7	ZD104R	I-11
Q106L	I-8	D100	D-6
Q106R	G-6	D101	H-8
Q107L	E-2	D102	I-7
Q107R	F-3	Q107R	F-3
Q108L	F-3	D104	G-7
Q108R	F-3	D105	F-2
Q109	E-2	D106	E-7
Q110	I-4	D107	E-6
Q111	I-4	D108	D-11
Q112	H-4	D109L	H-11
Q113L	E-2	D109R	H-11
Q113R	F-3	D110L	I-11
Q114L	E-4	D110R	I-11
Q114R	F-4	D111	F-6

8.1. Main P.C.B. Assy

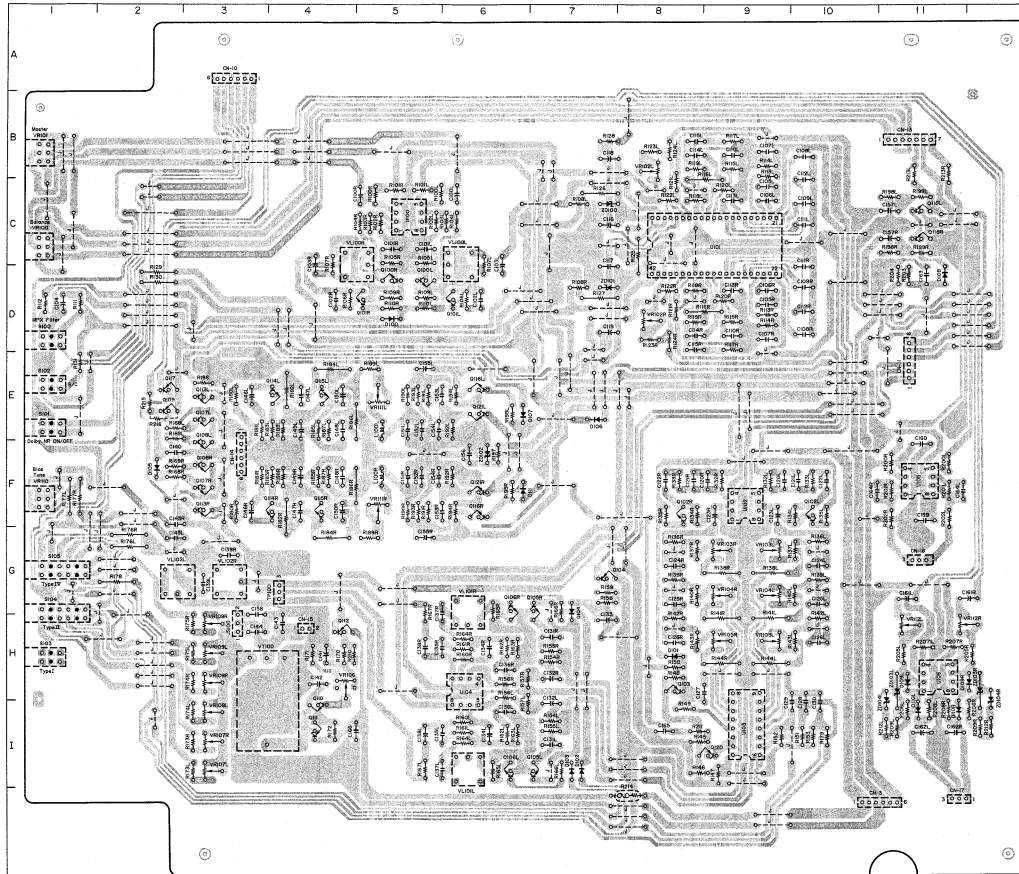

Fig. 8.1

*: Unstocked parts.

Schematic Part No.	Part No.	Description	Schematic Ref. No.	Part No.	Description	Schematic Part No.	Part No.	Description
8.1. Main P.C.B. Assy								
	* BA07959A	Main P.C.B. Assy	R124L,R	OB09707A	RK 18K 1/6W J	C102L,R	OB41275A	CM1 1200P 50V J
			R125	R130K	R 1/4W J	C102L,R	OB41276A	CE 1µ 50V (LN)
			R126,127	OB24272A	RF 6K 1/4W J	C104	OB40115A	CE 4.7µ 50V
			R128	OB09709A	RK 22K 1/6W J	C105L,R	OB41286A	CML 0.01µ 50V J
U100	OB06831B	IC NJM4558DD	R129,130	OB09701A	RK 10K 1/6W J	C106L,R	OB41433A	CFP 500P 100V G
U101	OB01464A	IC CX20188	R131	OB09689A	RK 3.3K 1/6W J	C107	OB41298A	CML 0.056µ 50V J
U102	OB06146A	IC NJM4558DD	R132L,R	OB09705A	RK 15K 1/6W J	C108L,R	CML 0.068µ 50V J	
U103	OB01427A	IC NJM4558DD	R133L,R	OB25277A	RM 715K 1/4W F	C109L,R	OB41302A	CML 0.22µ 50V J
U104	OB06387A	IC NJM2043DD	R134L,R	OB09745A	RK 1M 1/6W J	C110L,R	OB41288A	CML 0.015µ 50V J
U105	OB06370A	IC NJM4556D	R135L,R	OB09701A	RK 10K 1/6W J	C111L,R	OB41300A	CML 0.15µ 50V J
U106	OB06124A	IC NJM4556D	R136L,R	OB09709A	RK 22K 1/6W J	C112L,R	OB41306A	CML 0.47µ 50V J
Q100L,R	OB10033A	TR 25C1740S	R137L,R	OB09699A	RK 4.7K 1/6W J	C113L,R	OB41139A	CFP 390P 100V G
Q101L,R	OB10033A	TR 25C1740S	R138L,R	OB09680A	RK 10K 1/6W J	C114L,R	OB40090A	CE 47µ 25V
Q102L,R	OB10033A	TR 25C1740S	R139L,R	OB09705A	RK 15K 1/6W J	C115L,R	OB41133A	CFP 220P 100V G
Q103	OB10028A	TR DTA144ES	R140L,R	OB09692A	RK 4.3K 1/6W J	C116,117	OB40092A	CE 220µ 25V
Q104	OB10053A	TR DTA144ES	R141L,R	OB09682A	RK 1.6K 1/6W J	C119	OB40115A	CE 4.7µ 50V
Q105L,R	OB10067A	TR DTA143TS	R142L,R	OB09706A	RK 36K 1/6W J	C119	OB40090A	CE 47µ 25V
Q106L,R	OB10033A	TR 25C1740S	R143L,R	OB09701A	RK 10K 1/6W J	C120L,R	OB41277A	CML 1800P 50V J
Q107L,R	OB06142A	TR 25C2240 (BL)	R144L,R	OB09684A	RK 2K 1/6W J	C121L,R	OB41394A	CFP 220P 50V J
Q108L,R	OB06142A	TR 25C2240 (BL)	R145	OB09685A	RK 2.2K 1/6W J	C122L,R	OB41282A	CE 10µ 25V
Q109	OB10102A	TR 2SA1320	R146	OB09695A	RK 5.6K 1/6W J	C124L,R	OB41280A	CML 3300P 50V J
Q110	OB10033A	TR 25C1740S	R147	OB09725A	RK 100K 1/6W J	C125L,R	OB41276A	CML 1500P 50V J
Q111	OB06080A	TR DTA144ES	R148,149	OB09711A	RK 27K 1/6W J	C126L,R	OB41284A	CML 1800P 50V J
Q112	OB10053A	TR DTA144ES	R150	OB09738A	RK 220K 1/6W J	C127	OB41298A	CML 0.1µ 50V J
Q113L,R	OB10067A	TR DTA143TS	R151,152	OB09733A	RK 220K 1/6W J	C127	OB41298A	CML 0.1µ 50V J
Q114L,R	OB06142A	TR 25C2240 (BL)	R153	OB09738A	RK 220K 1/6W J	C128,129	OB41286A	CML 0.01µ 50V J
Q115L,R	OB06142A	TR 25C2240 (BL)	R154L,R	OB09711A	RK 27K 1/6W J	C130	OB41286A	CML 0.01µ 50V J
Q116L,R	OB10033A	TR 25C1740S	R155L,R	OB09711A	RK 27K 1/6W J	C131L,R	OB41139A	CML 1800P 50V J
Q117	OB10053A	TR DTA144ES	R156L,R	OB09677A	RK 1K 1/6W J	C132L,R	OB40112A	CE 1µ 50V
Q118L,R	OB10053A	TR DTA144ES	R157L,R	OB09741A	RK 470K 1/6W J	C133	OB40112A	CE 1µ 50V
Q120	OB10053A	TR DTA144ES	R158	OB09725A	RK 100K 1/6W J	C134	OB40756A	CML 22µ 25V (LN)
Q121L,R	OB10067A	TR DTC143TS	R159	OB09725A	RK 100K 1/6W J	C135L,R	CML 0.047µ 50V J	
ZD100,101	ZD101568A	ZD 10V	R160L,R	OB09735A	RK 270K 1/6W J	C136L,R	CML 2200P 50V J	
ZD102	OB12168A	ZD 10V	R161L,R	OB09719A	RK 56K 1/6W J	C137L,R	CML 5600P 50V J	
ZD103L,R	OB12273A	ZD 10V	R162L,R	OB09719A	RK 56K 1/6W J	C138L,R	CFP 390P 50V J	
ZD104L,R	OB12289A	ZD 5.1V	R163L,R	OB09691A	RK 3.9K 1/6W J	C139L,R	CFP 47P 50V J	
		MT755,1C	R164L,R	OB09671A	RK 56K 1/6W J	C140	OB41974A	CE 100P 50V J
		SID 15S176	R165L,R	OB09645A	RK 47K 1/6W J	C141,142	OB40112A	CE 1µ 50V
		SID 15S176	R166L,R	OB09725A	RK 15K 1/6W J	C142L,R	OB41433A	CFP 500P 50V J
		SID 18S176	R167L,R	OB09697A	RK 6.8K 1/6W J	C144	OB41414A	CFP 1500P 50V J
		SID 18S176	R168L,R	OB09695A	RK 5.6K 1/6W J	C145L,R	OB41974A	CE 100P 50V J
		SID 18S176	R169L,R	OB09705A	RK 6.8K 1/6W J	C146L,R	OB41414A	CFP 220P 50V J
		SID 18S176	R170	OB09693A	RK 4.7K 1/6W J	C147L,R	OB41394A	CML 0.018µ 50V J
		SID 18S176	R171	OB09708A	RK 20K 1/6W J	C148L,R	OB41289A	CE 47µ 16V (LN)
		SID 18S176	R172	OB09701A	RK 10K 1/6W J	C149L,R	OB40114A	CFP 390P 50V J
		SID 18S176	R173L,R	OB09695A	RK 15K 1/6W J	C150L,R	OB40112A	CE 3.3µ 50V J
		SID 18S176	R174L,R	OB09695A	RK 5.6K 1/6W J	C151L,R	OB41274A	CML 1000P 50V J
		SID 18S176	R175L,R	OB09653A	RK 10K 1/6W J	C152L,R	OB41400A	CFP 390P 50V J
		SID 18S176	R176L,R	OB1187A	RK 10K 1/6W J	C153L,R	OB41284A	CML 6800P 50V J
		L-C Block	R177L,R	OB01888A	RK 10K 1/4W J	C154L,R	OB41284A	CFP 47P 50V J
		Inductor 36mH	R178	OB09684A	RK 2K 1/6W J	C155L,R	OB40758A	CE 22µ 50V (LN)
		Inductor 36mH	R179	OB09710A	RK 24K 1/6W J	C156	OB40076A	CE 100µ 16V
		Inductor 36mH	R180L,R	OB09629A	RK 10 1/6W J	C157L,R	OB41128A	CE 3.3µ 50V J
		Inductor 36mH	R181L,R	OB09741A	RK 470K 1/6W J	C158	OB41420A	CFP 2700P 50V J
		Inductor 36mH	R182L,R	OB09380A	RK 100K 1/4W J	C159	Series No.:	
		Inductor 36mH	R183L,R	OB09651A	RK 82 1/6W J	C159,160	A32705801 -	
		Inductor 36mH	R184L,R	OB09330A	RK 100K 1/4W J	C160	CE 10µ 16V	
		Inductor 36mH	R185L,R	OB09731A	RK 180K 1/6W J	C161L,R	OB40078A	
		Inductor 36mH	R186L,R	OB25287A	RM 9.09K 1/4W F	C162L,R	OB40758A	
		Inductor 36mH	R187L,R	OB09711A	RK 27K 1/6W J	C163	CE 2.2µ 50V (LN)	
		Inductor 36mH	R188L,R	OB09685A	RK 2.2K 1/6W J	C164L,R	OB40114A	
		Inductor 36mH	R189L,R	OB09655A	RK 12K 1/6W J	C165	CFP 100P 50V J	
		Inductor 36mH	R190L,R	OB25301A	RM 12.7K 1/4W F	C166	CML 0.1µ 50V J	
		Inductor 36mH	R191L,R	OB09745A	RK 3.3K 1/4W F	C167	CFP 220P 50V J	
		Inductor 36mH	R192L,R	OB09749A	RK 1M 1/6W J	S101	Push Switch	
		Inductor 36mH	R193L,R	OB09716A	RK 43K 1/6W J	S102	Push Switch	
		Inductor 36mH	R194L,R	OB09718A	RK 43K 1/6W J	S103	Push Switch	
		Inductor 36mH	R195L,R	OB09675A	RK 100K 1/6W J	S104	Push Switch	
		Inductor 36mH	R196	OB09725A	RK 100K 1/6W J	S105	Push Switch	
		Inductor 36mH	R197	OB09677A	RK 1K 1/6W J	S106	Push Switch	
		Inductor 36mH	R198	OB09708A	RK 22K 1/6W J	S107	Push Switch	
		Inductor 36mH	R199L,R	OB09685A	RK 2.2K 1/6W J	S108	Push Switch	
		Inductor 36mH	R200L,R	OB09718A	RK 51K 1/6W J	S109	Push Switch	
		Inductor 36mH	R201L,R	OB09725A	RK 100K 1/6W J	S110	Push Switch	
		Inductor 36mH	R202L,R	OB09749A	RK 1M 1/6W J	S111	Push Switch	
		Inductor 36mH	R203	OB09677A	RK 1K 1/6W J	S112	Push Switch	
		Inductor 36mH	R204	OB09725A	RK 100K 1/6W J	S113	Push Switch	
		Inductor 36mH	R205L,R	OB09677A	RK 1K 1/6W J	S114	Push Switch	
		Inductor 36mH	R206L,R	OB09749A	RK 1M 1/6W J	S115	Push Switch	
		Inductor 36mH	R207L,R	OB09677A	RK 1K 1/6W J	S116	Push Switch	
		Inductor 36mH	R208L,R	OB09741A	RK 470K 1/6W J	S117	Push Switch	
		Inductor 36mH	R209L,R	OB09709A	RK 22K 1/6W J	S118	Push Switch	
		Inductor 36mH	R210	OB09701A	RK 10K 1/6W J	S119	Push Switch	
		Inductor 36mH	R211	OB09725A	RK 100K 1/6W J	S120	Push Switch	
		Inductor 36mH	R212L,R	OB09682A	RK 1.6K 1/6W J	S121	Push Switch	
		Inductor 36mH	R213L,R	OB09749A	RK 1M 1/6W J	S122	Push Switch	
		Inductor 36mH	R214	OB24023A	Fuse Resistor 1	S123	Push Switch	
		Inductor 36mH	R215,216	OB09717A	RK 47K 1/6W J	S124	Push Switch	
		Inductor 36mH	C101L,R	OB40756A	CE 1µ 50V (LN)	S125	Push Switch	
		Inductor 36mH		OB41758A	CML 2700P 50V J	S126	Push Switch	
		Inductor 36mH				S127	Push Switch	
		Inductor 36mH				S128	Push Switch	
		Inductor 36mH				S129	Push Switch	
		Inductor 36mH				S130	Push Switch	
		Inductor 36mH				S131	Push Switch	
		Inductor 36mH				S132	Push Switch	
		Inductor 36mH				S133	Push Switch	
		Inductor 36mH				S134	Push Switch	
		Inductor 36mH				S135	Push Switch	
		Inductor 36mH				S136	Push Switch	
		Inductor 36mH				S137	Push Switch	
		Inductor 36mH				S138	Push Switch	
		Inductor 36mH				S139	Push Switch	
		Inductor 36mH				S140	Push Switch	
		Inductor 36mH				S141	Push Switch	
		Inductor 36mH				S142	Push Switch	
		Inductor 36mH				S143	Push Switch	
		Inductor 36mH				S144	Push Switch	
		Inductor 36mH				S145	Push Switch	
		Inductor 36mH				S146	Push Switch	
		Inductor 36mH				S147	Push Switch	
		Inductor 36mH				S148	Push Switch	
		Inductor 36mH				S149	Push Switch	
		Inductor 36mH				S150	Push Switch	
		Inductor 36mH				S151	Push Switch	
		Inductor 36mH				S152	Push Switch	
		Inductor 36mH				S153	Push Switch	
		Inductor 36mH				S154	Push Switch	
		Inductor 36mH				S155	Push Switch	
		Inductor 36mH				S156	Push Switch	
		Inductor 36mH				S157	Push Switch	
		Inductor 36mH				S158	Push Switch	
		Inductor 36mH				S159	Push Switch	
		Inductor 36mH				S160	Push Switch	
		Inductor 36mH				S161	Push Switch	
		Inductor 36mH				S162	Push Switch	
		Inductor 36mH				S163	Push Switch	
		Inductor 36mH				S164	Push Switch	
		Inductor 36mH				S165	Push Switch	
		Inductor 36mH				S166	Push Switch	
		Inductor 36mH						

8.2. Power Supply & Logic P.C.B. Assy

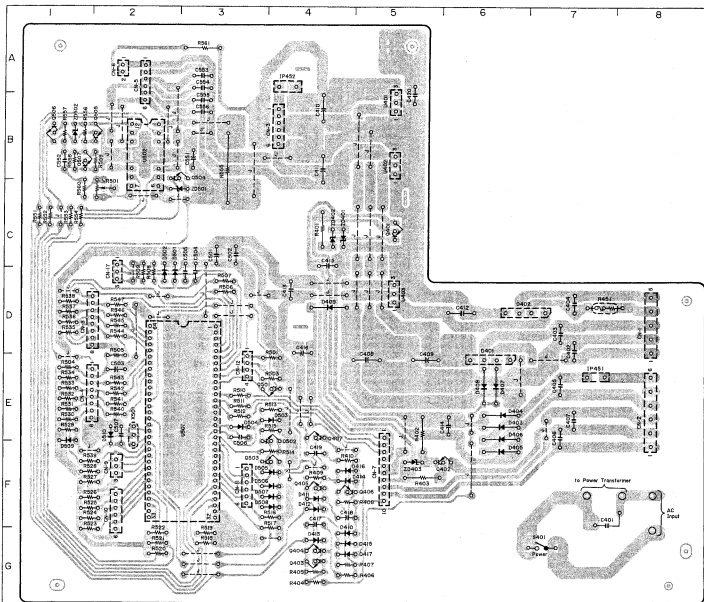

Fig. 8.2

• Semiconductor Location

Ref. No.	Location	Ref. No.	Location	Ref. No.	Location
U401	B-5	Q505	B-2	D411	F-4
U402	B-5	Q506	B-1	D412	F-4
U403	D-5	Q507	B-1	D413	G-4
U501	E-3	ZD401	C-4	D414	F-4
U502	B-2	ZD402	C-4	D415	G-4
IP451	E-7	ZD403	F-5	D416	F-4
IP452	A-4	ZD501	C-3	D417	G-4
Q401	C-5	ZD502	B-1	D501	D-2
Q402	F-6	D401	E-6	D502	D-2
Q403	G-4	D402	D-6	D503	E-4
Q404	G-4	D403	E-6	D504	E-3
Q405	F-4	D404	E-6	D505	F-4
Q406	F-4	D405	F-6	D506	F-4
Q407	E-4	D406	E-6	D507	F-4
Q501	E-4	D407	E-6	D508	F-4
Q502	E-4	D408	E-6	D509	F-1
Q503	F-4	D409	D-4	D510	E-2
Q504	B-3	D410	G-4		

*: Unstocked parts.

Schematic Ref. No.	Part No.	Description	Schematic Ref. No.	Part No.	Description
8.2. Power Supply & Logic P.C.B. Assy			— Power Supply —		
	* BA07944A	Power Supply & Logic P.C.B. Assy (USA, CAN, EP, UK, AUS, SAU, OTR)	Q402	OB06303A	TR 2SB772
	* BA07961A	Power Supply & Logic P.C.B. Assy (JPN)	Q403,404	OB10030A	TR 28C17408
	— Logic —		Q405	OB10062A	TR DTC144ES
			Q406	OB10053A	TR DTA144ES
			Q407	OB10062A	TR DTC144ES
			IP451	IC OB11725A	IC ICP-N10-T104RC 0.4A
					IC ICP-N20-T104RC 0.8A
U501	OB11861A	IC μ PD75106CW	ZD401	OB12314A	ZD 12V
U502	OB11368A	IC LB1649	ZD402	OB12317A	MTZ12B
Q501	OB10068A	TR DTC114ES			ZD 13V
Q502	OB10030A	TR 28C17408	ZD403	OB12285A	MTZ13B
Q503	OB10053A	TR DTA144ES			ZD 4.7V
Q504	OB10062A	TR DTC144ES	D401,402	OB06282A	MTZ4.7A
Q505	OB10026A	TR 2S4933S			SID
Q506	OB10062A	TR DTC144ES	D403,404	OB12365A	DBA10B/DBA10C
Q507	OB10030A	TR 28C17408	D405,406	OB12365A	SID 1SR35-100A
Q5101	OB12288A	ZD 5.1V	D407,408	OB12365A	SID 1SR35-100A
ZD502	OB12288A	ZD 5.1V	D409	OB12365A	SID 1SR35-100A
D501,502	OB06398A	SID 1SS176	D410,411	OB06398A	SID 1SS176
D503,504	OB06398A	SID 1SS176	D412,413	OB06398A	SID 1SS176
D505,506	OB06398A	SID 1SS176	D414,415	OB06398A	SID 1SS176
D507,508	OB06398A	SID 1SS176	D416,417	OB06398A	SID 1SS176
D509,510	OB06398A	SID 1SS176	R401	CR 405,406	CR 2.7K 1/4W J
R501	OB09303A	Crystal 4.0MHz	R402	OB01681A	RR 3.3K 1/4W J
VR501	OB32192A	Semi VR 5K	R403	OB01706A	RR 47 1/4W J
R501	OB09701A	RR 10K 1/6W J	R404	OB09709A	RR 22K 1/6W J
R503	OB09701A	RR 10K 1/6W J	R405	OB09703A	RR 32K 1/6W J
R504	OB09687A	RR 1K 1/6W J	R406	OB09733A	RR 220K 1/6W J
R505,506	OB09677A	RR 1K 1/6W J	R407	OB09725A	RR 100K 1/6W J
R507	OB09677A	RR 1K 1/6W J	R408	OB09717A	RR 47K 1/6W J
R508,509	OB09701A	RR 10K 1/6W J	R409	OB09733A	RR 220K 1/6W J
R510	OB09677A	RR 1K 1/6W J	R410	OB09701A	RR 10K 1/6W J
R511,512	OB09677A	RR 1K 1/6W J	R451	OB24023A	Fuse Resistor 1 CC 4700P 400V
R513	OB09699A	RR 4.7K 1/6W J	C401	OB41825A	CC 0.1 μ F 50V Z
R514,4,515	OB09701A	RR 10K 1/6W J			CC 0.1 μ F 50V Z
R516	OB09699A	RR 4.7K 1/6W J	OB41826A	OB47117A	CC 0.1 μ F 50V Z
R517	OB09701A	RR 10K 1/6W J			CC 0.1 μ F 50V Z
R518,519	OB09701A	RR 10K 1/6W J	C402,403	OB47117A	CC 0.1 μ F 50V Z
R520,521	OB09701A	RR 10K 1/6W J	C404,405	OB47117A	CC 0.1 μ F 50V Z
R522,523	OB09701A	RR 10K 1/6W J	C406,407	OB47117A	CC 0.1 μ F 50V Z
R524,525	OB09701A	RR 10K 1/6W J	C408	OB40097A	CE 3300 μ 25V
R526	OB09701A	RR 10K 1/6W J	C409	OB40096A	CE 2200 μ 25V
R527,528	OB09701A	RR 10K 1/6W J	C410,411	OB40084A	CE 3200 μ 16V
R529	OB09699A	RR 4.7K 1/6W J	C412	OB40085A	CE 4700 μ 16V
R530	OB09701A	RR 10K 1/6W J	C413	OB40082A	CE 1000 μ 16V
R531,532	OB09701A	RR 10K 1/6W J	C414	OB40121A	CE 220 μ 50V
R533,534	OB09701A	RR 10K 1/6W J	C415	OB40104A	CE 100 μ 35V
R535	OB09701A	RR 10K 1/6W J	C416	OB40497A	CE 470 μ 25V
R536,537	OB09701A	RR 10K 1/6W J	C417	OB40758A	CE 2.2 μ 50V (LN)
R538	OB09701A	RR 10K 1/6W J	C418	OB40754A	CE 0.47 μ 50V (LN)
R539	OB09677A	RR 1K 1/6W J	C419	OB40753A	CE 0.33 μ 50V (LN)
R540,541	OB09677A	RR 1K 1/6W J	C420	OB47117A	CC 0.1 μ F 50V Z
R542,543	OB09677A	RR 1K 1/6W J	S401	OB71012A	Power Switch
R544,545	OB09677A	RR 1K 1/6W J			
R546,547	OB09677A	RR 1K 1/6W J			
R551,552	OB09677A	RR 1K 1/6W J			
R553,554	OB09677A	RR 1K 1/6W J			
R555	OB24273A	RF 27 3W			
R556	OB09701A	RR 10K 1/6W J			
R557	OB09688A	RR 1.5K 1/6W J			
R558	OB09699A	RR 5.6K 1/6W J			
R559	OB09717A	RR 47K 1/6W J	CN1	OB81323A	5P-T Post VH
R560	OB09677A	RR 1K 1/6W J	CN2	OB81573A	6P-T Post VH
R561	OB09688A	RR 1.5K 1/6W J	CN3	OB83896A	6P Connector Assy
C501	OB40078A	CE 100 μ 16V	CN4	OB81465A	8P-T Post
C502	OB47117A	CC 0.1 μ F 50V Z	CN5	OB81463A	6P-T Post
C503	OB40023A	CML 0.22 μ 50V Z	CN6	OB81459A	2P-T Post
C504,505	OB41533A	CC 0.01 μ 25V Z	CN7	OB10F-T Post	10P-T Post
C506,507	OB41944A	CC 1000P 50V K	CN8	OB84296A	8P-T Post
C551	OB40078A	CE 100 μ 16V	CN9	OB84281A	3P-T Post
C552	OB41286A	CML 0.01 μ 50V Z	CN10	OB83900B	6P Connector Assy
C553,554	OB41533A	CC 0.01 μ 25V Z	CN11	OB83901B	6P Connector Assy
C555,556	OB41533A	CC 0.01 μ 25V Z	CN12	OB83902B	4P Connector Assy
			CN17	OB83915B	3P Connector Assy
					Wrapping Terminal 2P (3)
					Earth Plane (1)
U401	OB11862A	IC NJM7812FA			
U402	OB11863A	IC NJM7912FA			
U403	OB11753A	IC NJM7805FA			
Q401	OB06451A	TR 2SB1015			
	OB00766A	M3x8 ϕ Binding (4)			
	OJ06256A	Heat Sink (1)			

8.3. Timer Switch P.C.B. Assy

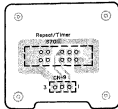

Fig. 8.3

8.4. Headphone P.C.B. Assy

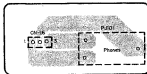

Fig. 8.4

Schematic Ref. No.	Part No.	Description
	* BA07947A	Timer Switch P.C.B. Assy
S701	OB60837B	Timer Switch P.C.B.
CN9	OB70175A	Slide Switch 2-4
	OB83899A	3P Connector Assy
8.4. Headphone P.C.B. Assy		
	* BA07960A	Headphone P.C.B. Assy
PJ101	OB60832B	Headphone P.C.B.
CN16	OB81478A	Headphone Jack
	OB83904A	3P Connector Assy
		Power Supply & Logic P.C.B.
		5P-T Post VH
		6P-T Post VH
		6P Connector Assy
		8P-T Post
		6P-T Post
		2P-T Post
		10P-T Post
		8P-T Post
		3P-T Post
		6P Connector Assy
		6P Connector Assy
		4P Connector Assy
		3P Connector Assy
		Wrapping Terminal 2P (3)
		Earth Plane (1)

8.5. Pin Jack P.C.B. Ass'y

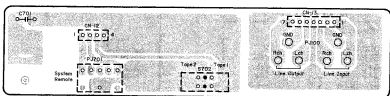

Fig. 8.5

8.6. Shut-off P.C.B. Ass'y

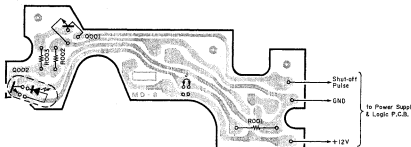

Fig. 8.6

8.7. Control Switch & Display P.C.B. Ass'y

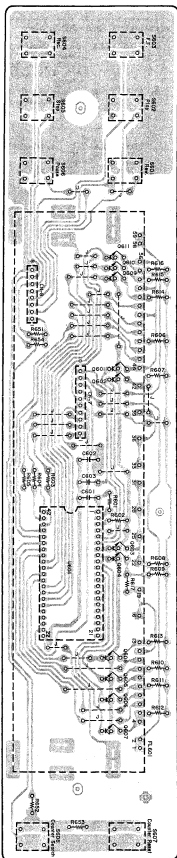

Fig. 8.7

*: Unstocked parts.

Schematic Ref. No.	Part No.	Description	Schematic Ref. No.	Part No.	Description
8.5. Pin Jack P.C.B. Ass'y			8.7. Control Switch & Display P.C.B. Ass'y		
	* BA07946A	Pin Jack P.C.B. Ass'y		* BA07945A	Control Switch & Display P.C.B. Ass'y
C701	OB60836B	Pin Jack P.C.B.	U601	OB11860A	IC MSC7112-01SS
S702	OB41553A	CC 0.01 μ	Q601.602	OB10030A	TR 25C1740S
FJ100	OB84334A	Pin Jack 4P	Q603.604	OB10030A	TR 25C1740S
FJ701	OB84028A	Stereo Mini	Q605.606	OB10030A	TR 25C1740S
CN12	OB81461A	4P-T Post	Q607.608	OB10030A	TR 25C1740S
CN13	OB83903A	7P Connector Ass'y	Q609.610	OB10030A	TR 25C1740S
	OE03355A	Earth Plate (1)	Q611	OB10030A	TR 25C1740S
8.6. Shut-off P.C.B. Ass'y			R601	OB09713A	RK 33K 1/6W J
	* CA80011B	Shut-off P.C.B. Ass'y	R602	OB09701A	RK 10K 1/6W J
Q001	OC80047A	Shut-off P.C.B.	R603.604	OB09677A	RK 1K 1/6W J
Q002	OB06388A	TR 25C2612	R605	OB09677A	RK 1K 1/6W J
	OB06389A	Photo Reflector	R606.607	OB09717A	RK 47K 1/6W J
	NJL5141		R608	OB09717A	RK 47K 1/6W J
R001	OC81330A	RM 760	R609.610	OB09717A	RK 47K 1/6W J
R002	OB09841A	RK 15K	R611.612	OB09717A	RK 47K 1/6W J
R003	OB09840A	RK 680	R613.614	OB09717A	RK 47K 1/6W J
			R615.616	OB09717A	RK 47K 1/6W J
			R617	OB09629A	RK 10 1/6W J
			R651	OB09701A	RK 10K 1/6W J
			R652	OB09693A	RK 4.7K 1/6W J
			R653	OB09705A	RK 15K 1/6W J
			R654	OB09701A	RK 10K 1/6W J
			C601	OB41974A	CC 100P 50V J
			C602	OB40158A	CE 10 μ 5.5V
			C603	OB40173A	CE 1 μ 50V
			S601.602	OB70161A	Tact Switch
			S603.604	OB70161A	Tact Switch
			S605.606	OB70161A	Tact Switch
			S607.608	OB70161A	Tact Switch
			CN7	OB83897A	10P Connector Ass'y
			CN8	OB83989A	8P Connector Ass'y
			FL601	OB90461A	FL Display
				0J06219C	FL Cushion (2)
				0J06238A	FL Stopper (2)

9. SCHEMATIC DIAGRAMS

9.1. IC Block Diagrams

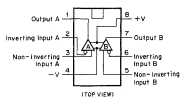
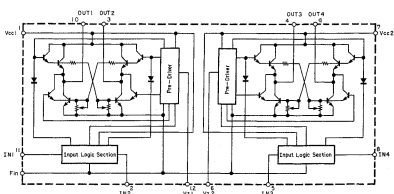

Fig. 9.1.1 Operational Amp. IC 4558D, 4558DD, 4556D, 4556D, 2043DD



INPUT	IN1/3	IN2/4	OUTPUT	OUT1/3	OUT2/4	OPERATION
0	0	0	0	0	0	Braking
1	0	0	0	0	0	Forward Inherent
0	1	0	1	0	0	Reverse (Free-wheel)
1	1	0	0	0	0	Braking

Fig. 9.1.2 Motor Driver IC LB1649

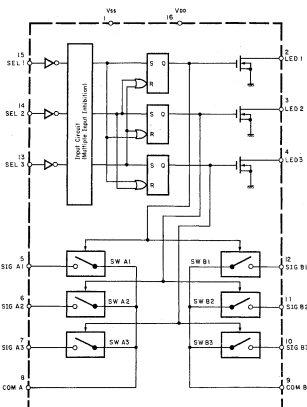
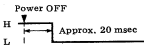
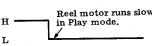
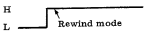
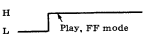

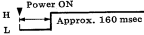

Fig. 9.1.3 Analog Switch Selector TC9145P

U501 μ PD75106CW (Microprocessing Unit (MPU))

Pin No.	Signal Name	In/Out	Function
1	—	I	Not used. Connected to GND.
2	—	I	Not used. Connected to GND.
3	REM	I	Remote control receiver signal input.
4	RELP	I	Reel motor pulse input. Pulse train is input while take-up reel hub is rotating, i.e., tape is running.
5	LVR	I	Rch input for level meter. Input level is A/D-converted in this IC and the converted result is transferred to the Display Control IC (U601) via pin 13 (DDAT).
6	LVL	I	Lch input for level meter. The function is the same as above LVR (Rch).
7	KS1	I	Record switch input. "L" when pressed.
8	KS0	I	Stop/Counter Search/Counter Reset switch input. Stop switch ON: 0 V Counter Search switch ON: 1.6 V Counter Reset switch ON: 3.3 V
9	MREM	I	System remote mode signal input. "L": "Tape 1" is selected. "H": "Tape 2" is selected.
10	HD2/3	I	Connected to GND.
11	—	O	Not used. (Open)
12	DCLK	O	Clock for serial data DDAT at pin 13.
13	DDAT	O	Serial data for Display Control IC (U601), which includes display data and control information.
14	DEN	O	Enable signal to Display Control IC (U601). Active "H".
15	—	I	Not used. Connected to GND.
16	—	I	Not used. Connected to GND.
17	—	I	Not used. Connected to GND.
18	POFF	I	Power OFF signal input. Becomes "L" when power is turned OFF. 
19	LMUT	O	Line mute signal output. Active "L".
20	RMUT	O	Record mute signal output. Active "L". Record mute is released only in Record/Play mode.
21	BIAS	O	Bias ON/OFF signal output. "L": Bias ON.
22	—	O	Not used. (Open)
23	—	O	Not used. (Open)
24	—	O	Not used. (Open)
25	HPLY	O	Record/Playback head select signal output. "L": Playback mode. "H": Record mode.
26	HREC	O	Record/Playback head select signal output. L: Record mode. "L": Playback mode.
27	RMSP	O	Reel motor speed select signal output. Becomes "L" in play mode. 

Pin No.	Signal Name	In/Out	Function															
28	—	O	Not used. (Open)															
29	RMR	O	Reel motor drive control signal output. Becomes "H" in Rewind mode. 															
30	RMF	O	Reel motor drive control signal output. Becomes "H" in Play or Fast Forward mode. 															
31	NC	—	No connection.															
32	VDD	—	Supplied with +5 V.															
33	—	O	Not used. (Open)															
34	—	O	Not used. (Open)															
35	ASMR	O	Control motor reverse drive signal output. Becomes "H" when turning the control motor reverse (in the direction of Play-Pause-Stop-FF/REW). 															
36	ASMF	O	Control motor forward drive signal output. Becomes "H" when turning the control motor forward (in the direction of FF/REW-Stop-Pause-Play). 															
37	TAP B	I	Tape type select signal input. <table border="1" data-bbox="657 764 854 837"> <thead> <tr> <th>Type</th> <th>TAP A</th> <th>TAP B</th> </tr> </thead> <tbody> <tr> <td>Type I</td> <td>H</td> <td>H</td> </tr> <tr> <td>Type II</td> <td>L</td> <td>H</td> </tr> <tr> <td>Type IV</td> <td>H/L</td> <td>L</td> </tr> </tbody> </table>	Type	TAP A	TAP B	Type I	H	H	Type II	L	H	Type IV	H/L	L			
Type	TAP A	TAP B																
Type I	H	H																
Type II	L	H																
Type IV	H/L	L																
38	TAP A	I																
39	B/C	I	Dolby NR mode select signal input. <table border="1" data-bbox="657 880 885 953"> <thead> <tr> <th>Mode</th> <th>DLBY</th> <th>B/C</th> </tr> </thead> <tbody> <tr> <td>Dolby NR OFF</td> <td>H</td> <td>H/L</td> </tr> <tr> <td>Dolby NR B</td> <td>L</td> <td>H</td> </tr> <tr> <td>Dolby NR C</td> <td>L</td> <td>L</td> </tr> </tbody> </table>	Mode	DLBY	B/C	Dolby NR OFF	H	H/L	Dolby NR B	L	H	Dolby NR C	L	L			
Mode	DLBY	B/C																
Dolby NR OFF	H	H/L																
Dolby NR B	L	H																
Dolby NR C	L	L																
40	DLBY	I																
41	MPX	I	MPX filter switch signal input. "L": MPX Filter ON, "H": OFF															
42	TIM B	I	Repeat/Timer switch signal input. <table border="1" data-bbox="657 1033 885 1128"> <thead> <tr> <th>Mode</th> <th>TIM A</th> <th>TIM B</th> </tr> </thead> <tbody> <tr> <td>OFF</td> <td>H</td> <td>H</td> </tr> <tr> <td>Auto Repeat</td> <td>L</td> <td>H</td> </tr> <tr> <td>Timer Play</td> <td>H</td> <td>L</td> </tr> <tr> <td>Timer Record</td> <td>L</td> <td>L</td> </tr> </tbody> </table>	Mode	TIM A	TIM B	OFF	H	H	Auto Repeat	L	H	Timer Play	H	L	Timer Record	L	L
Mode	TIM A	TIM B																
OFF	H	H																
Auto Repeat	L	H																
Timer Play	H	L																
Timer Record	L	L																
43	TIM A	I																
44	REC PRO	I	Record protect switch signal input. "H": Recording is allowed.															
45	RESET	I	System reset signal input. Active "L". 															

Pin No.	Signal Name	In/Out	Function
46	X2	—	4 MHz crystal is connected.
47	X1	—	4 MHz crystal is connected.
48	—	O	Not used, (Open)
49	MREC	O	Record mode signal output. Active "L".
50	MPLY	O	Play mode signal output. Active "L".
51	MSTP	O	Stop mode signal output. Active "L".
52	RREM	O	System remote return signal output.
53	—	O	Not used, (Open)
54	—	O	Not used, (Open)
56	EJC	I	Cassette In switch signal input. Becomes "L" while the Cassette Cover Assy is open.
57	CAM2	I	Cam switch signal input. Mode of the mechanism can be sensed according to states of CAM0, CAM1 and CAM2.
58	CAM1	I	Cam switch signal input. Mode of the mechanism can be sensed according to states of CAM0, CAM1 and CAM2.
59	CAM0	I	Cam switch signal input. Mode of the mechanism can be sensed according to states of CAM0, CAM1 and CAM2.
60	KFF	I	FF switch signal input, "L" when pressed.
61	KREW	I	REW switch signal input, "L" when pressed.
62	KPUS	I	Pause switch signal input, "L" when pressed.
63	KPLY	I	Play switch signal input, "L" when pressed.
64	VSS	—	Grounded.

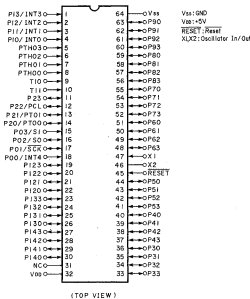

(TOP VIEW)

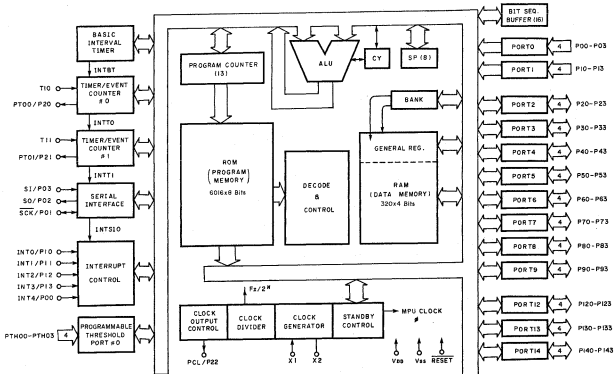

Fig. 9.1.4 Microprocessing Unit (MPU) μPD75106CW

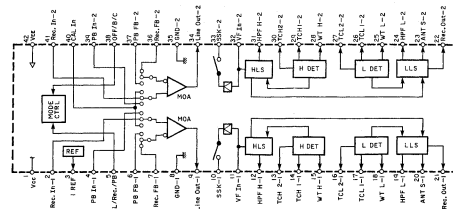

Fig. 9.1.5 Dolby NR IC CX20188

U101 CX20188 (Dolby NR IC)

Pin No.	Signal Name	Function
1	Vcc	Positive power supply input terminal.
2,41	Rec. In	Record signal input terminal.
3	I Ref.	Reference current input terminal.
4,39	PB In	PB signal input terminal.
5	CAL/Rec./PB	Calibration/Recording/Playback select terminal.
6,37	PB FB	Playback signal feedback terminal.
7,36	Rec. FB	Record signal feedback terminal.
8,35	GND	GND terminal.
9,34	Line Out	Line signal (decoded signal) output terminal.
10,33	SSK	Spectral skewing switch terminal.
11,32	VF In	Encode circuit input terminal.
12,31	HPF H	HLS high-pass filter terminal.
42	TCH 2	HLS detector time constant determination terminal 2.

Pin No.	Signal Name	Function
14,29	TCH 1	HLS detector time constant determination terminal 1.
15,28	WT H	HLS weighting terminal.
16,27	TCL 2	HLS detector time constant determination terminal 2.
17,26	TCL 1	LLS detector time constant determination terminal 1.
18,25	WT L	LLS weighting terminal.
19,24	HPF L	LLS high-pass filter terminal.
20,23	ANT S	Anti-saturation terminal.
21,22	Rec. Out	Record signal (encoded signal) output terminal.
38	OFF/B/C	Dolby NR OFF/B-type/C-type select terminal.
40	CAL In	Calibration input terminal. Not used.
42	Vegp	Negative power supply input terminal.

U601 MSC7112 (Display Controller)

Pin No.	Signal Name	In/Out	Function
1	OSCI 1	I	An RC circuit is connected for making an oscillation circuit.
2	OSCO	O	
3	FOR	I	Reset signal input at power ON. The IC is reset when "L".
4	VDD	—	Supplied with +5 V.
5	D1 to D12	I/O	FL tube grid drive output. (D8-D12 are not used.)
17	LED1 to LED5	O	Not used, (Open)
21	VSS	—	Grounded.

Pin No.	Signal Name	In/Out	Function
23	VEE	—	Supplied with -25 V.
24	SEG P to SEG A	O	FL tube anode drive output. Active "H". (SEG P - SEG A are not used.)
40	SCLK	I	Shift clock input for internal shift register. Shifts the data at pin 41 (DATAIN) at every rising edge.
41	DATAIN	I	Control & display serial data sent from the mechanism control MPU (U501). MSB first.
42	LOAD	I	Data latch pulse. The data is latched to the internal register at the falling edge.

9.2. Schematic Diagrams
(1) Amplifier Section

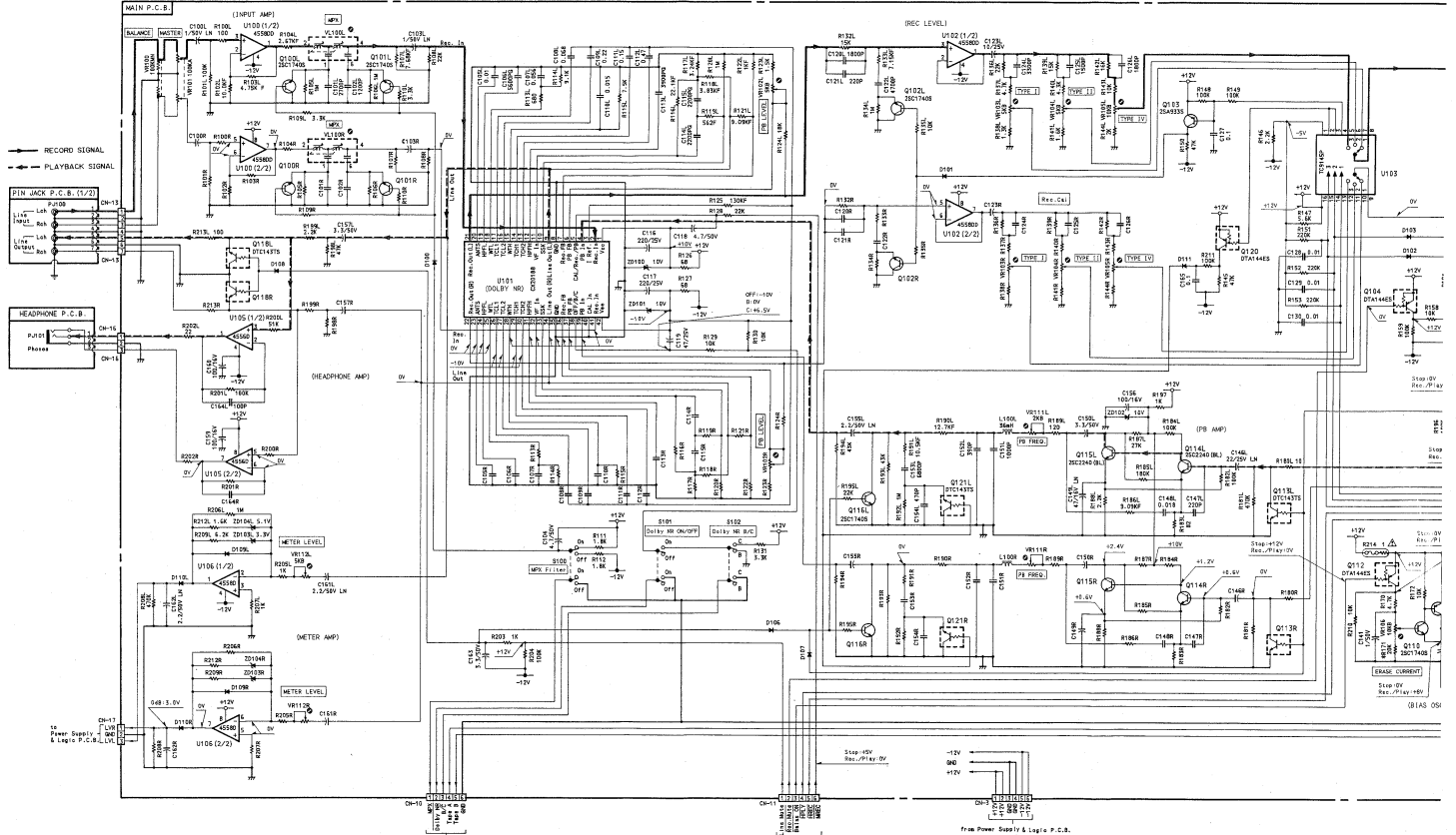









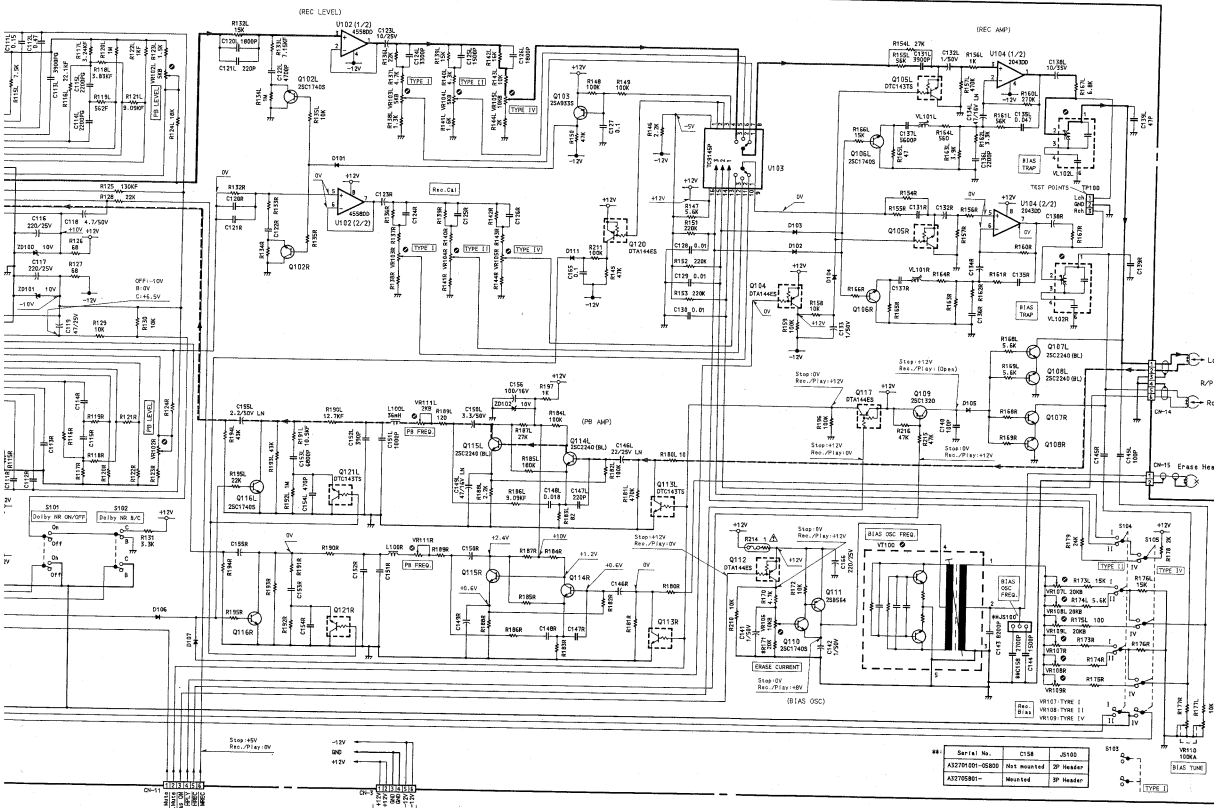



to Power Supply & Logic P.C.B.

from Power Supply & Logic P.C.B.

from Power Supply & Logic P.C.B.

Fig. 9.2.1



-  C 8
-  2SA938S
-  2SC1740S
-  DTC144ES
-  DTC1483S
-  DTC144ES
-  2SC2812
-  2SB564
-  2SB772
-  2SB1015
-  7812
-  7805

*: Parts marked with * show typical value.

from Power Supply & Logic P.C.B.

from Power Supply & Logic P.C.B.

Fig. 9.2.1

Serial No.	C158	J5102
A2270101-05800	Not Mounted	2P Header
A22702001-	Mounted	2P Header

(2) MECHANISM CONTROL Section

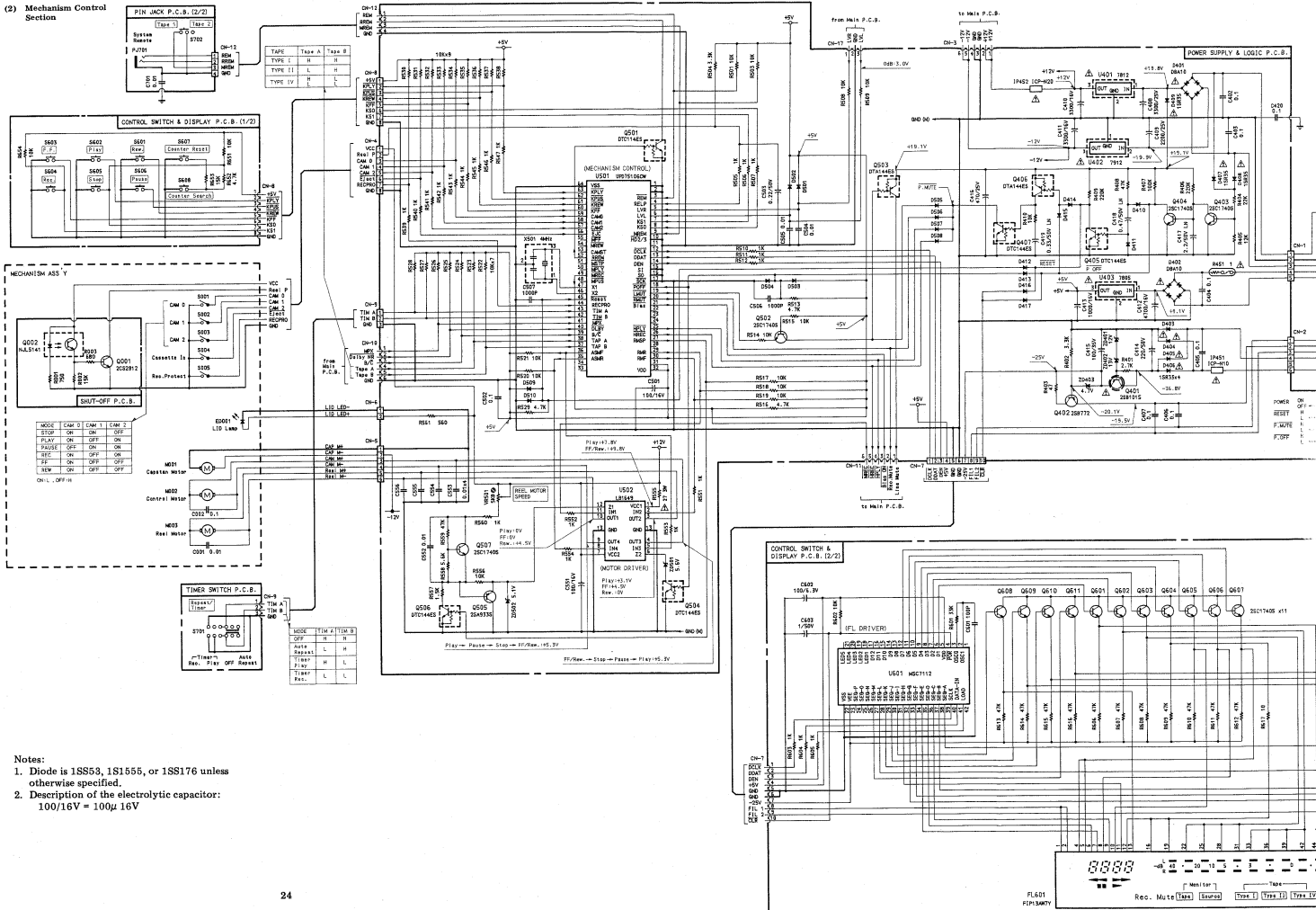

- Notes:
1. Diode is 1S853, 1S1555, or 1S8176 unless otherwise specified.
 2. Description of the electrolytic capacitor:
100/16V = 100µ 16V

Fig. 9.2.2

WARNING:
 Parts marked with the symbol  have critical characteristics.
 Use **ONLY** replacement parts recommended by the manufacturer.

It is recommended that the unit be operated from a suitable DC supply or batteries during initial check-out procedures.

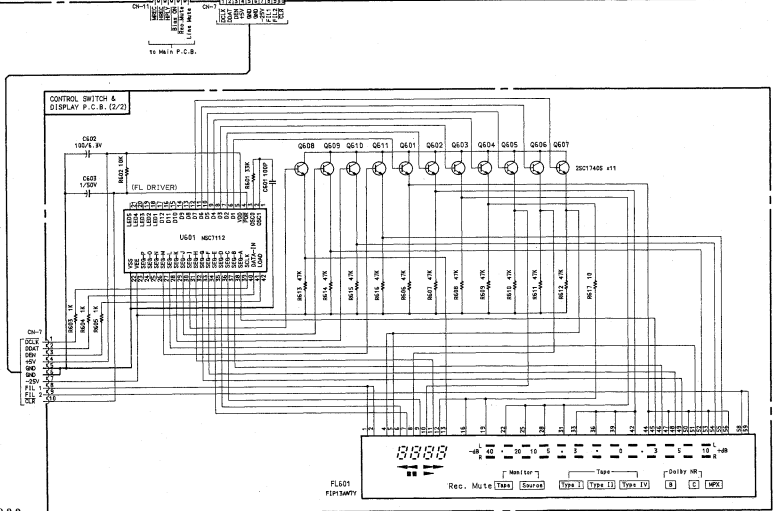
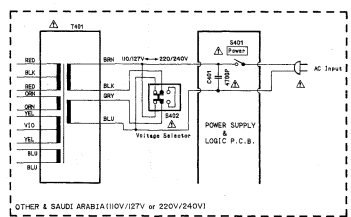
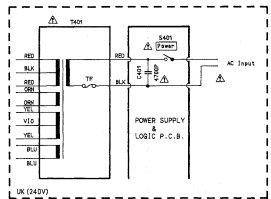
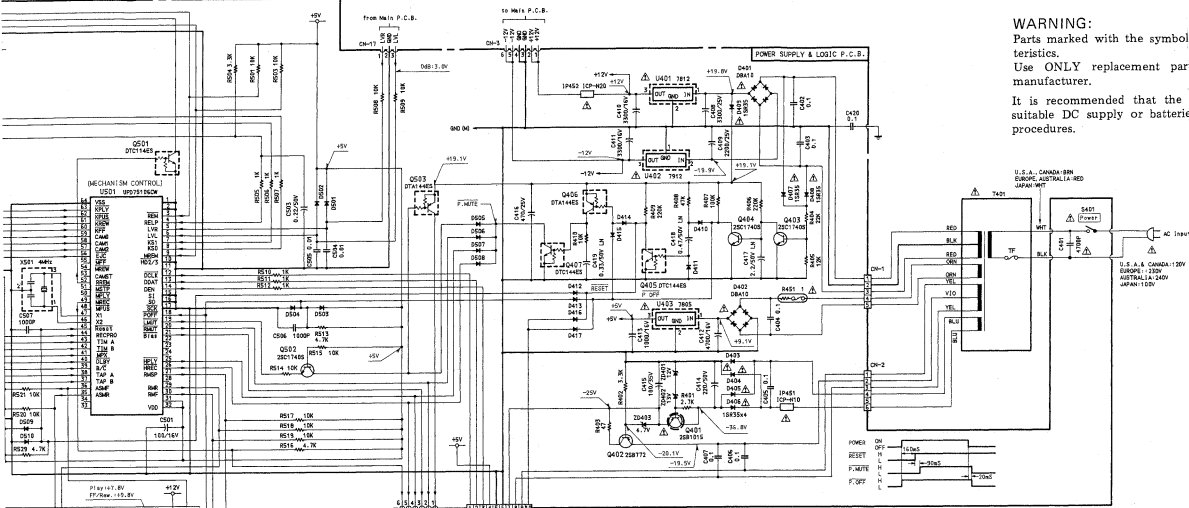

Fig. 9.2.2

10. WIRING DIAGRAM

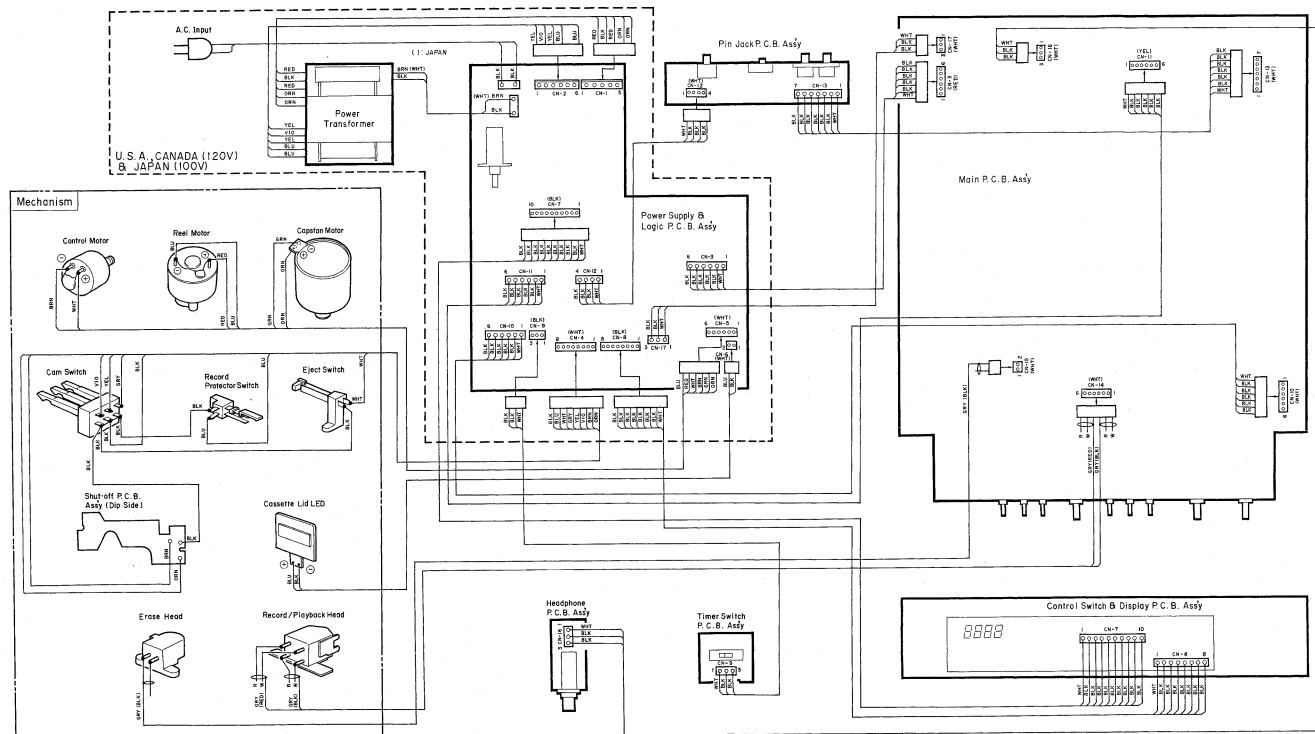

FIG. 10.1

Notes: 1. Table of wire colors

BRN - Brown	BLU - Blue
RED - Red	VIO - Violet
ORN - Orange	GRY - Gray
YEL - Yellow	WHT - White
GRN - Green	BLK - Black

2. Component side view of the P.C.B. is illustrated unless otherwise specified.

3. Wire tube color is shown in ().

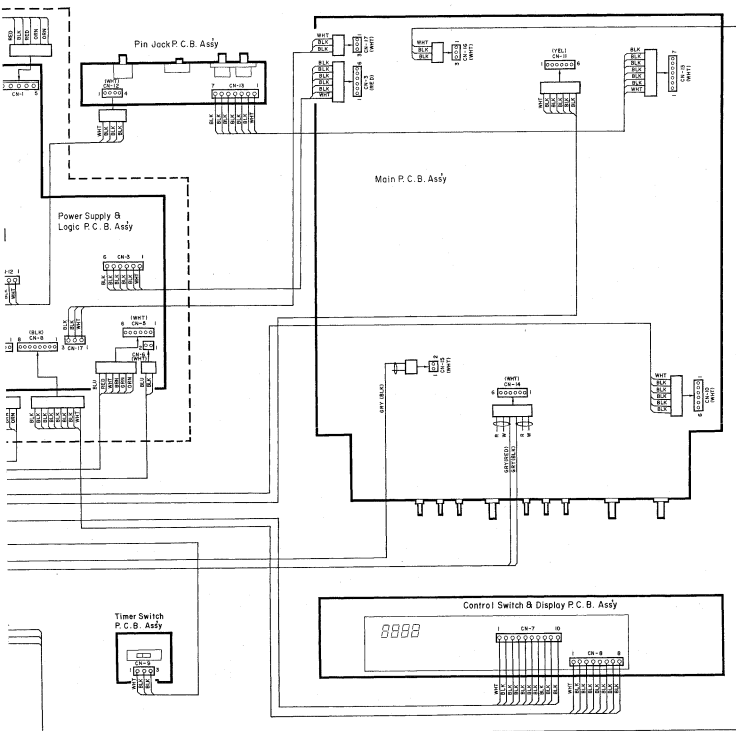

Fig. 10.1

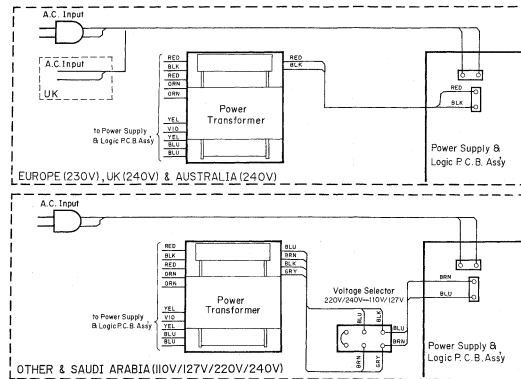

Fig. 10.2

11. BLOCK DIAGRAMS

11.1. Amplifier Section

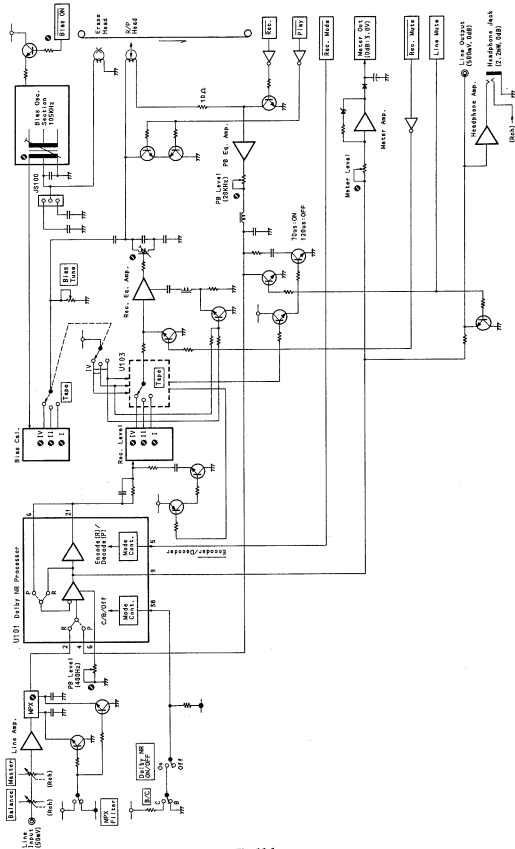

Fig. 11.1

11.2. Mechanism Control Section

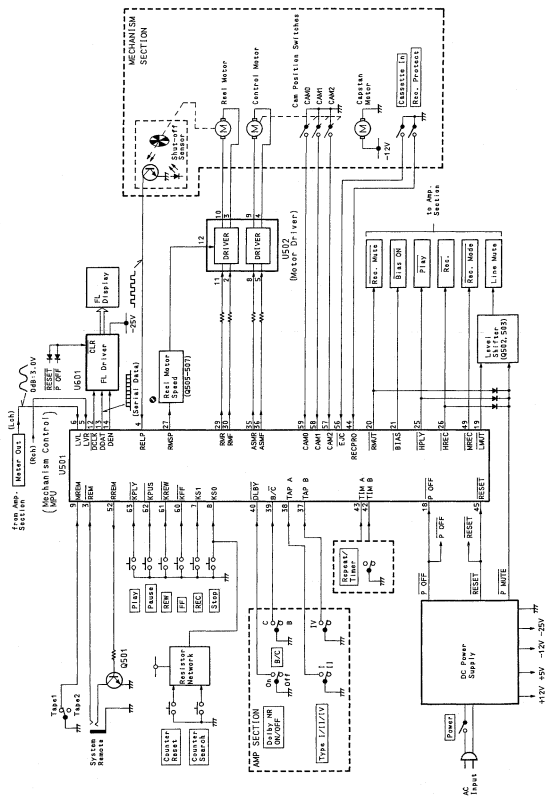

Fig. 11.2

12. TIMING CHARTS AND EQ. AMP. FREQUENCY RESPONSE

12.1. Timing Charts

(1) Overall Timing Chart

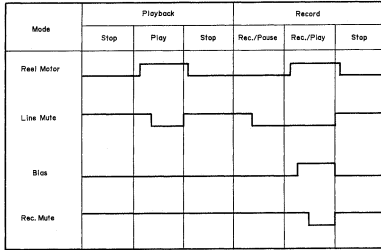

Fig. 12.1.1

(2) Mechanism Control Timing Chart

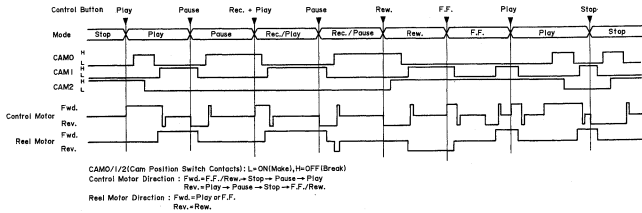

Fig. 12.1.2

12.2. Eq. Amp. Frequency Response
(1) Playback Frequency Response

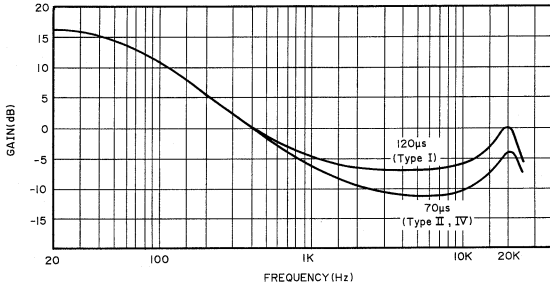

Fig. 12.2.1

(2) Record Current Frequency Response

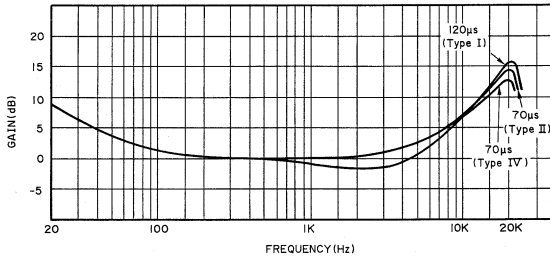

Fig. 12.2.2

13. SPECIFICATIONS

Track Configuration	4 tracks/2-channel stereo
Heads	2 (erase head x 1, record/playback x 1)
Motors	
<Tape Transport>	DC servo motor (capstan drive) x 1
DC motor (reel drive)	x 1
<Mechanism>	DC motor (cam drive) x 1
Power Source	120, 220, 240 or 110/127/220/240 V, 50/60 Hz
Power Consumption	25 W max.
Tape Speed	1-7/8 ips. (4.8 cm/sec.) $\pm 0.5\%$
Wow and Flutter	less than $\pm 0.11\%$ WTD Peak less than 0.06% WTD RMS
Frequency Response	20-20,000 Hz ± 3 dB
Signal to Noise Ratio	
Dolby C-Type NR On	Better than 70 dB (400 Hz, 3% THD, IHF A-WTD RMS)
<70 μ s, Type IV>	
Dolby B-Type NR On	Better than 64 dB (400 Hz, 3% THD, IHF A-WTD RMS)
<70 μ s, Type IV>	
Total Harmonic Distortion	Less than 1.2% <400 Hz, 0 dB Type I/IV> Less than 1.6% <400 Hz, 0 dB, Type II>
Erase	Better than 60 dB (100 Hz, +10 dB)
Channel Separation	Better than 36 dB (1 kHz, 0 dB)
Crosstalk	Better than 60 dB (1 kHz, 0 dB)
Bias Frequency	105 Hz
Input (Line)	50 mV/40 k Ω
Output	
Line	0.5 V (400 Hz, 0 dB)
Headphones	2.2 mW/8 Ω (400 Hz, 0 dB)
Fast-Wind Time	Approx. 95 seconds (with C-60 cassette)
Dimensions*	430 (W) x 100 (H) x 320 (D) mm 16-15/16 (W) x 3-15/16 (H) x 12-5/8 (D) inches
Approximate Weight	5.4 kg/11 lbs. 14 oz.

*: Dimensions do not include protruding parts. Height is the panel height.

- Specifications and Design are subject to change for further improvement without notice.
- Dolby noise reduction manufactured under license from Dolby Laboratories Licensing Corporation.
- "DOLBY" and the double-D symbol $\square\square$ are trademarks of Dolby Laboratories Licensing Corporation.