

SERVICE INFORMATION

for

499

 **SCOTT**[®]
where innovation is a tradition

H. H. Scott, Inc., 111 Powdermill Road, Maynard, Mass. 01754

499 PARTS LIST

PART NUMBER	DESCRIPTION	PART NUMBER	DESCRIPTION
011-1004-024	Can Electrolytic Capacitor- 10,000/50v	020-1111-020	Power Transistor
011-1006-025	Tubular Electrolytic Capacitor	021-1123-021	Wire Wound Resistor
012-1022-002	Diode, Stabistor, Dual	021-1125-068	Potentiometer, Balance
012-1025-002	Full Wave Bridge Silicon Rectifier	021-1125-069	Potentiometer, Loudness, Quad
013-1031-011	Slo-Blo Fuse, F-SB-2.5	021-1126-004	Packaged Circuit (Res.& CC)
013-1031-008	Slo-Blo Fuse, F-SB-1 $\frac{1}{2}$ /250v	023-1135-003	Slide Switch
015-1061-005	Earphone Jacks	023-1135-004	Slide Switch, Conversion
015-1061-010	Phone Jacks	023-1135-016	Slide Switch, Poswe
017-1095-018	VU Meters	023-1135-028	Slide Switch, Double, Black Button
018-1104-023	Channel Indicator Plate	023-1137-048	Rotary Switch
018-1100-055	Single Knobs	023-1137-047	Rotary Switch
018-1100-056	Front Knobs	024-1140-042	Power Transformer
018-1100-057	Master Volume Knobs	026-1152-004	Line Cord
018-1100-058	Rear Knobs	030-1189-008	Pilot Light
020-1111-019	Power Transistor	030-1189-014	Pilot Light
100-1333-018	Tape Head Preamp Boards		
100-1333-019	Preamp Boards		
100-1334-002	Tone Control Boards		
100-1335-010	Driver Amp Boards		
100-1340-012	Power Supply Board		
100-1340-015	Power Supply/Meter Board		
100-1352-003	Push Button Switch Board		

NOTE - THIS PARTS LIST CONTAINS ONLY THOSE NON-STANDARD ITEMS WHICH MUST BE ORDERED FROM THE FACTORY.

H. H. SCOTT, INC.
PARTS DEPARTMENT
111 POWDER MILL ROAD
MAYNARD, MA 01754

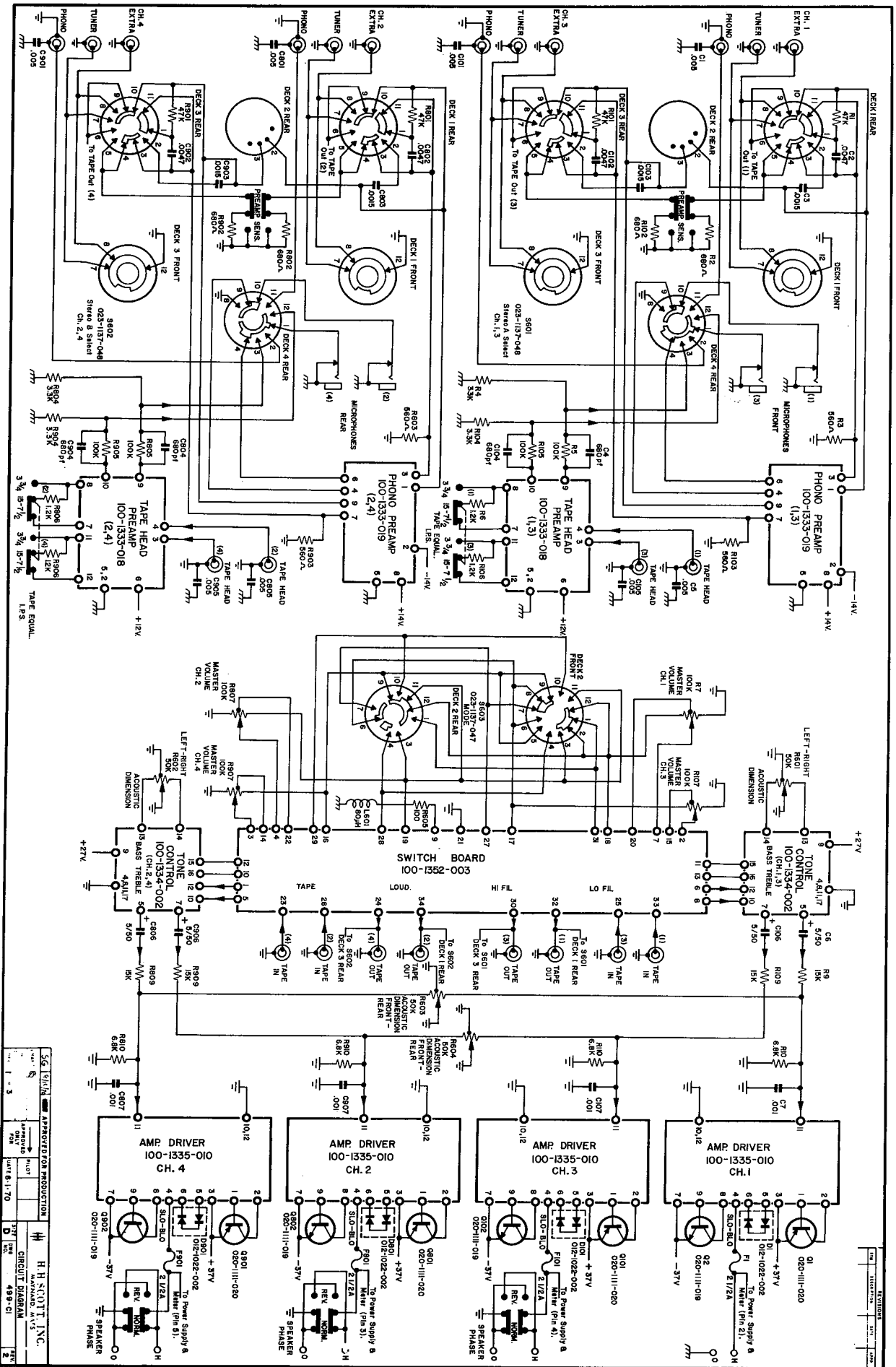

SG ELECTRONIC APPROVED FOR PRODUCTION
 H. H. SCOTT, INC.
 MANHATTAN, N.Y.
 DATE 6-1-70
 DRAWING NO. 499-C1

DATE 6-1-70
 DRAWING NO. 499-C1

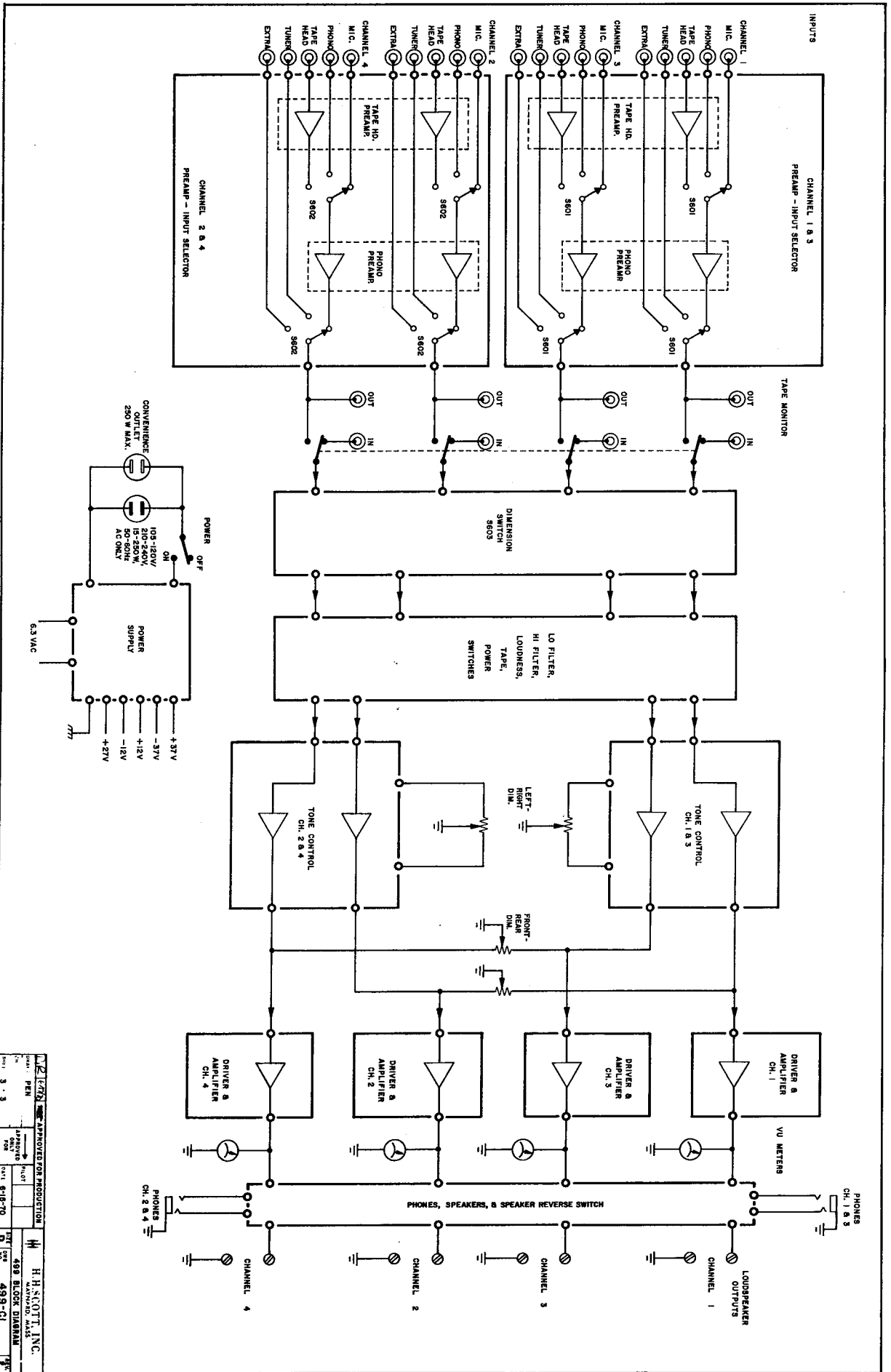

APPROVED FOR PRODUCTION		H. H. SCOTT, INC.	
DATE	REV.	DATE	REV.
1967	3	1967	3
488 BLOCK DIAGRAM		489-CI	

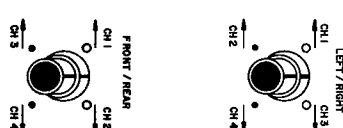
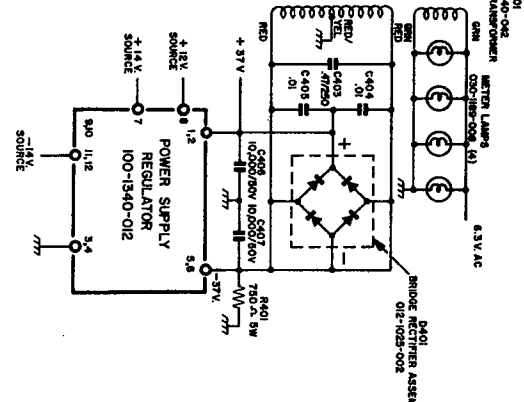
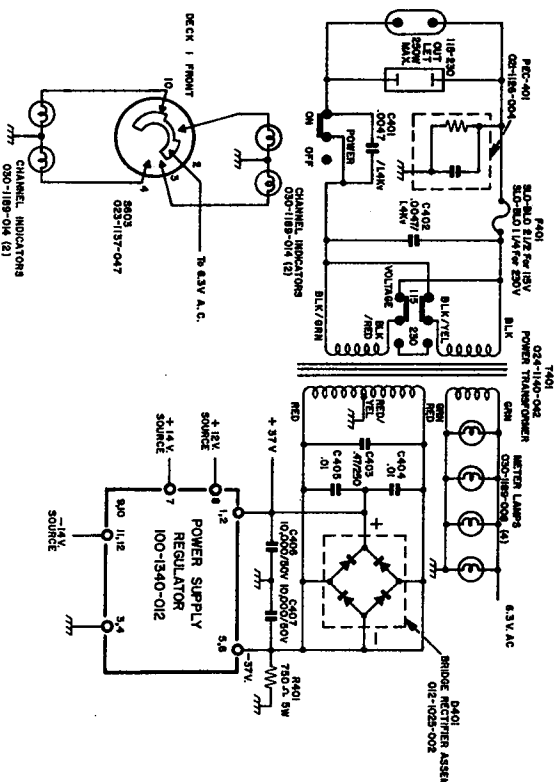
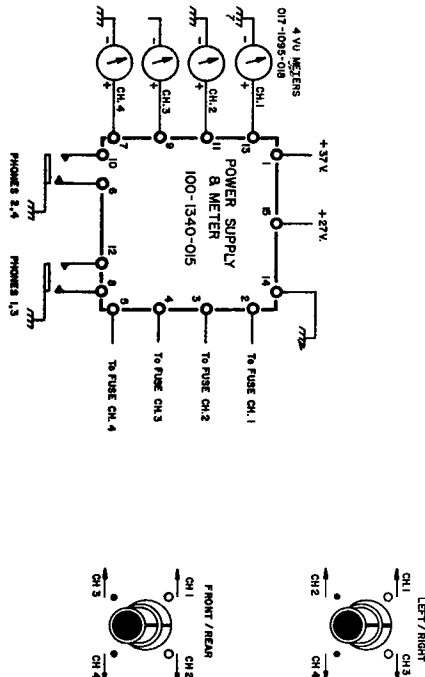

- NOTES:
1. MAIN POWER SUPPLY
 2. OUTPUT TRANSISTOR
 3. D.C. OFFSET ADJUSTMENT MUST BE ACCURATE
 4. D.C. OFFSET ADJUSTMENT MUST BE ACCURATE
 5. D.C. OFFSET ADJUSTMENT MUST BE ACCURATE
 6. D.C. OFFSET ADJUSTMENT MUST BE ACCURATE
 7. D.C. OFFSET ADJUSTMENT MUST BE ACCURATE
 8. D.C. OFFSET ADJUSTMENT MUST BE ACCURATE
 9. D.C. OFFSET ADJUSTMENT MUST BE ACCURATE
 10. D.C. OFFSET ADJUSTMENT MUST BE ACCURATE
 11. HIGHEST SERIES NUMBERS:

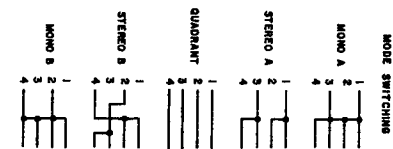
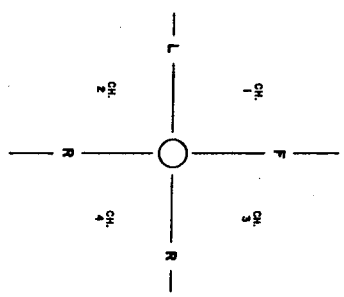

DATE	REV	BY	CHK	APP	DATE	REV	BY	CHK	APP
1970	2				1970	1			
APPROVED FOR PRODUCTION					H. H. SCOTT, INC.				
DATE: 8-4-70					CIRCUIT DIAGRAM				
REV: 2					REV: 1				
REV: 3					REV: 2				

REV	DATE	BY	CHK	APP
1	1970			
2	1970			
3	1970			

REV.	DESCRIPTION	DATE	APP.
1	ECO 3177	1-7-70	SG
2	ECO3688	6-9-71	EM
3	ECO 3799	8-17-71	SG

CIRCUIT DIAGRAM 100-1333-019

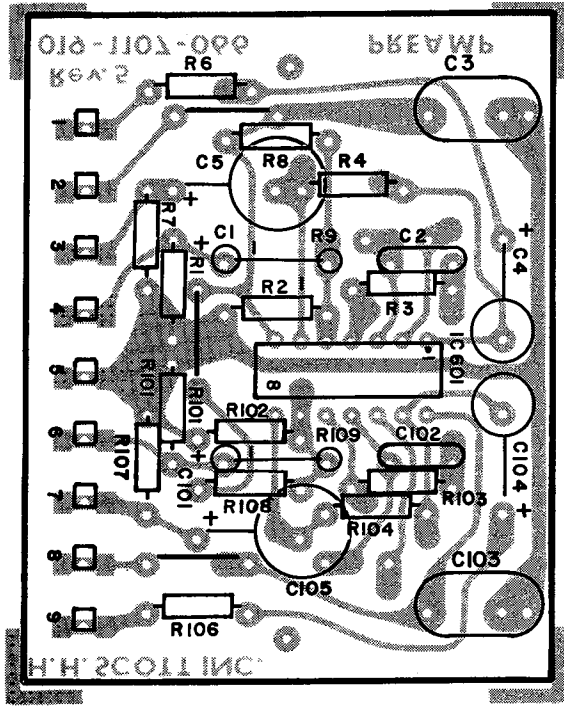

PRE AMP 019-1107-066/A REV. 1

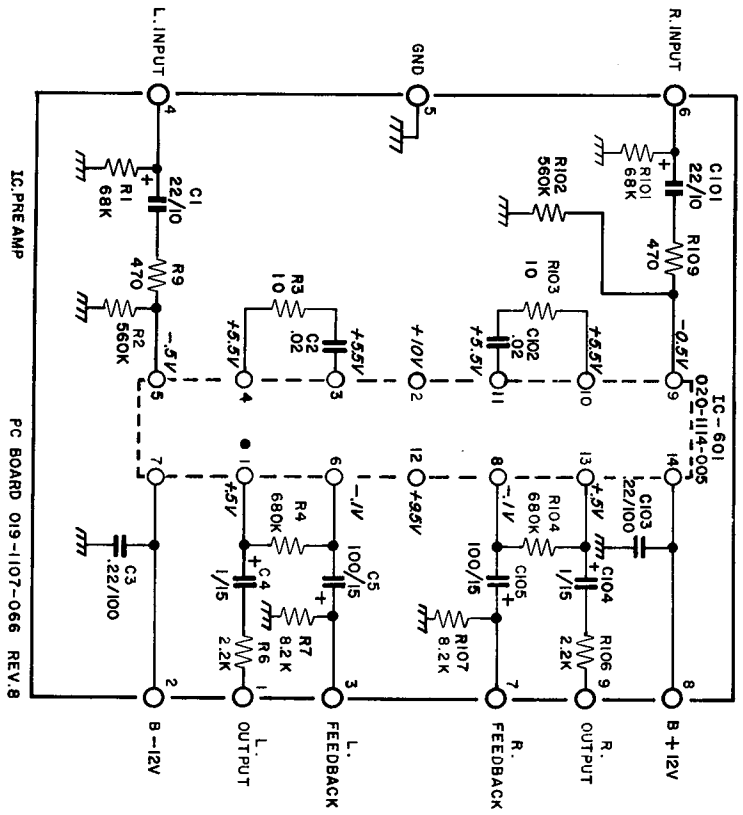

- NOTES:
1. UNLESS OTHERWISE SPECIFIED, ALL RESISTANCE IN OHMS, ±10%, 1/4 WATT, CAPACITANCE IN MICROFARADS.
 2. HIGHEST SERIES NUMBERS ARE: R9, R109, C8, C103, IC-601.
 3. CIRCLE MARK ON TOP OR INDENTATION ON LEG OF IC INDICATES PIN NO.1.
 4. VOLTAGES SHOWN DO NOT APPLY TO 2506-07.
 5. R5, R103, R8 AND R108 ARE DELETED.
 6. REFER TO COMPONENT LABEL, 019-1107-066/A
 7. UNLESS OTHERWISE SPECIFIED ALL VOLTAGES ARE DC ±15% MEASURED WITH 20KΩ/V V.O.M.

IC: PRE AMP PC BOARD 019-1107-066 REV. 8

UNLESS OTHERWISE SPECIFIED ALL DIMENSIONS ARE IN INCHES TOLERANCES ON FRACTIONS 1/16 DECIMALS .005 ANGLES 1:7		SG <i>Blithe</i> APPROVED FOR PRODUCTION		H.H. SCOTT, INC. MAYNARD, MASS.	
DRAWN	J.A.	APPROVED	ONLY	PILOT	SCALE
ENG.	B.F.T.	FOR	SAMPLE	QUOTE	IC PRE AMP
PROD.					SIZE DWG 100 1333 019
MATERIAL					C NO. 3
FINISH					SCALE 1:1 SHEET 1 OF 1 DATE 12/17/69

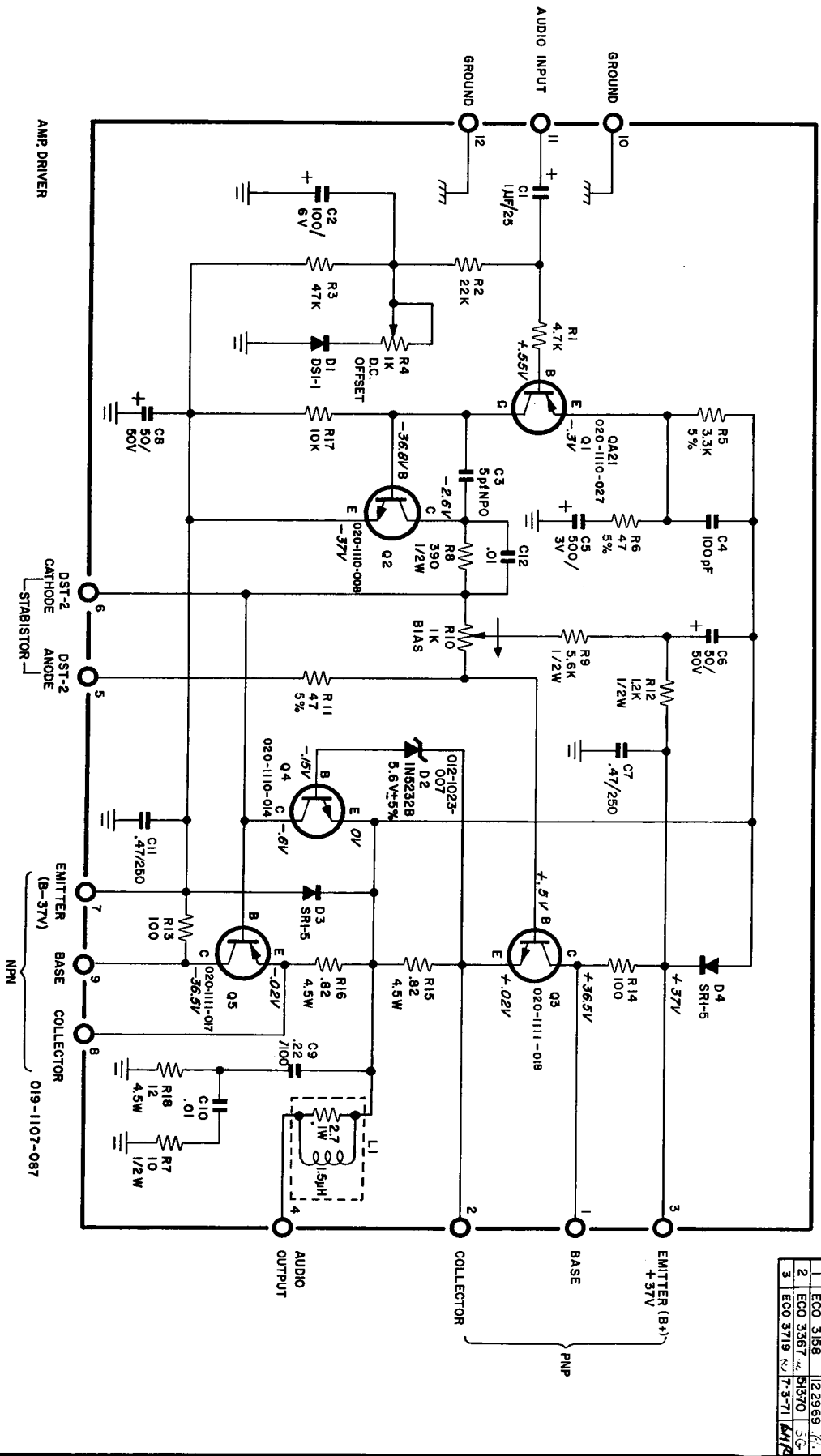

NOTES:
 1. UNLESS OTHERWISE SPECIFIED: ALL RESISTANCE IN OHMS ±10%,
 CAPACITANCE IN MFD'S, RESISTORS 1/4 WATT, AND VOLTS ARE
 D.C. ±15% MEASURED WITH 20KΩ/VOLT V.O.M.
 2. HIGHEST SERIES NUMBERS: R18, Q2, D4, Q5, L1

REV	DESCRIPTION	DATE	APP
1	ECO 3158	12/29/69	AM
2	ECO 3367	5/3/70	SG
3	ECO 3719	7-3-71	AM

H. H. SCOTT, INC.
 MAYNARD, MASS.

SIZE	DWG	NO.	SHEET	OF	DATE
	AMP DRIVER	100-1335-010	1	1	10/28/69

- Q1 ; 020-1110-027
- Q2 ; 020-1110-008 (5-010)
- 020-1110-038 (5-011)
- Q3 ; 020-1111-018
- Q4 ; 020-1110-014
- Q5 ; 020-1111-017

100-1335-011
 CIRCUIT 100-1335-010 REV.2

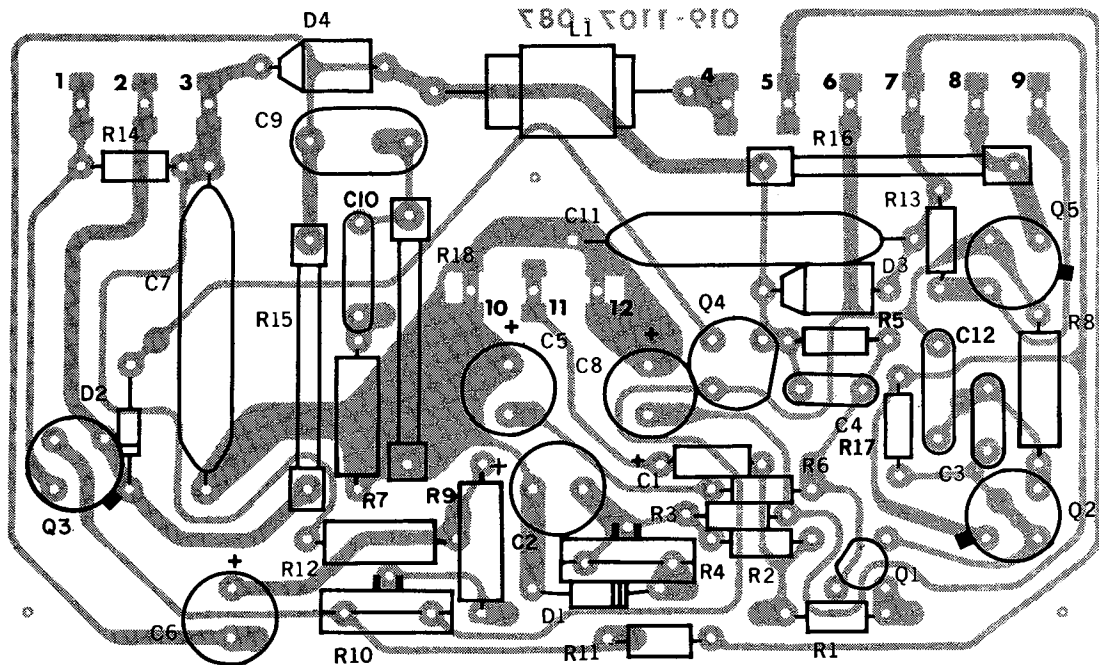

DRIVER

019-1107-087 REV. 2

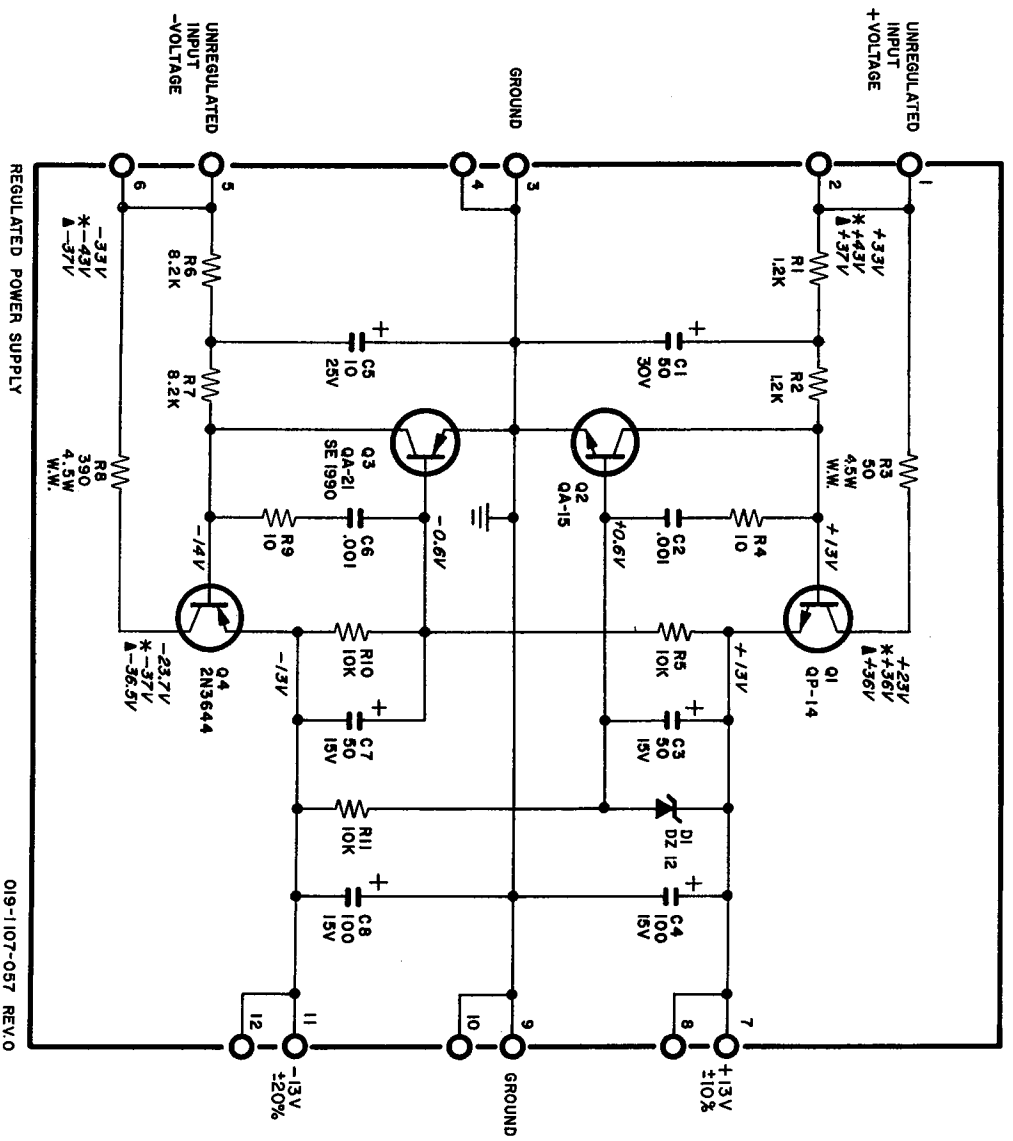

REGULATED POWER SUPPLY
019-1107-057 REV.0

NOTES:

1. UNLESS OTHERWISE SPECIFIED: ALL RESISTANCE IN OHMS ±10%, CAPACITANCE IN MFD'S, RESISTORS 1/4 WATT, AND VOLTS ARE DC. ±5% MEASURED WITH 20KΩ/VOLT V.O.M.
2. HIGHEST SERIES NUMBERS: R11, C8, D1, Q4
3. UNREGULATED INPUT VOLTAGE RANGE ±(25V TO 44V)
4. * INDICATES THE ONLY VOLTAGES WHICH CHANGE WITH 43V INPUT, (387).
5. Δ INDICATES THE ONLY VOLTAGES WHICH CHANGE WITH 37V INPUT, (499).

REVISIONS		
SYM	DESCRIPTION	DATE
1	ECO 3040	10-11-68
2	ECO 3368	10-9-70
3	ECO 3699	6-14-71

H. H. SCOTT, INC.
MAYNARD, MASS.

REGULATED POWER SUPPLY

SIZE	REV
C	3
DWG. NO.	100-1340-012
SHEET	1 OF 1
DATE	10-29-68

- Q4 020-1110-004
- Q3 020-1110-005
- Q2 020-1110-013
- Q1 020-1111-005

CIRCUIT DIAGRAM 100-1340-012

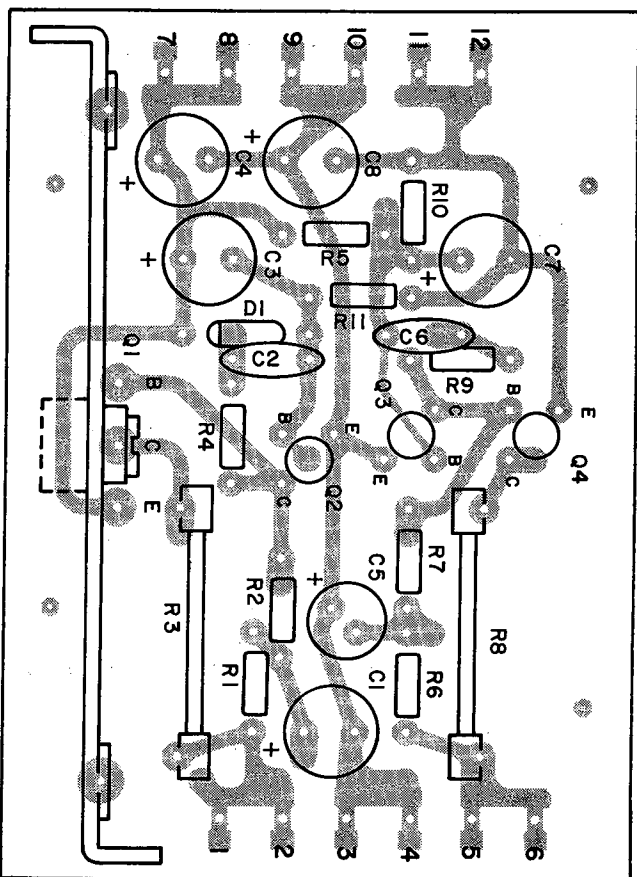

H.H.S. POWER SUPPLY

019-1107-057 REV.2

REVISIONS	
SYN	DATE

1 2 3 4 5 6 7 8 9 10

Q401, 020-1110-008
CIRCUIT DIAGRAM 100-1340-015

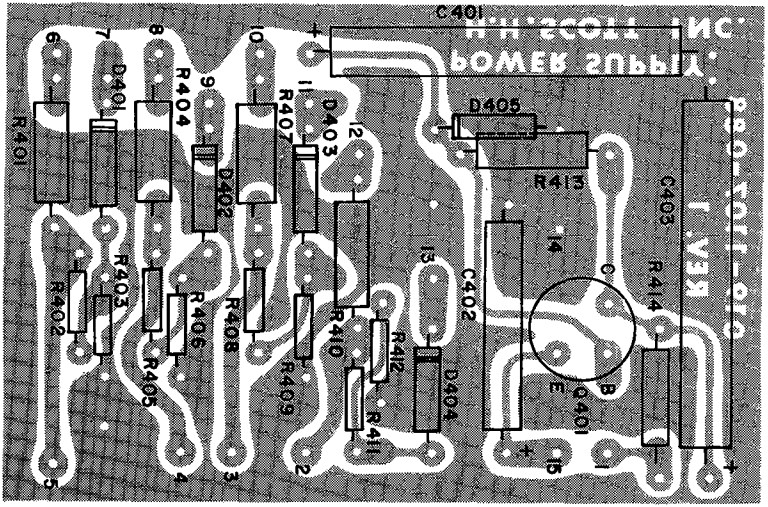

POWER SUPPLY 019-1107-088
REV. 0

- NOTES:
1. UNLESS OTHERWISE SPECIFIED; RESISTANCE IN OHMS $\pm 10\%$ 1/4 WATT, CAPACITANCE IN MFDS.
 2. HIGHEST SERIES NOS. R414, C403, D404, Q401.
 3. UNLESS OTHERWISE SPECIFIED ALL VOLTAGES ARE DC $\pm 15\%$ MEASURED WITH 20K Ω /V V.O.M.

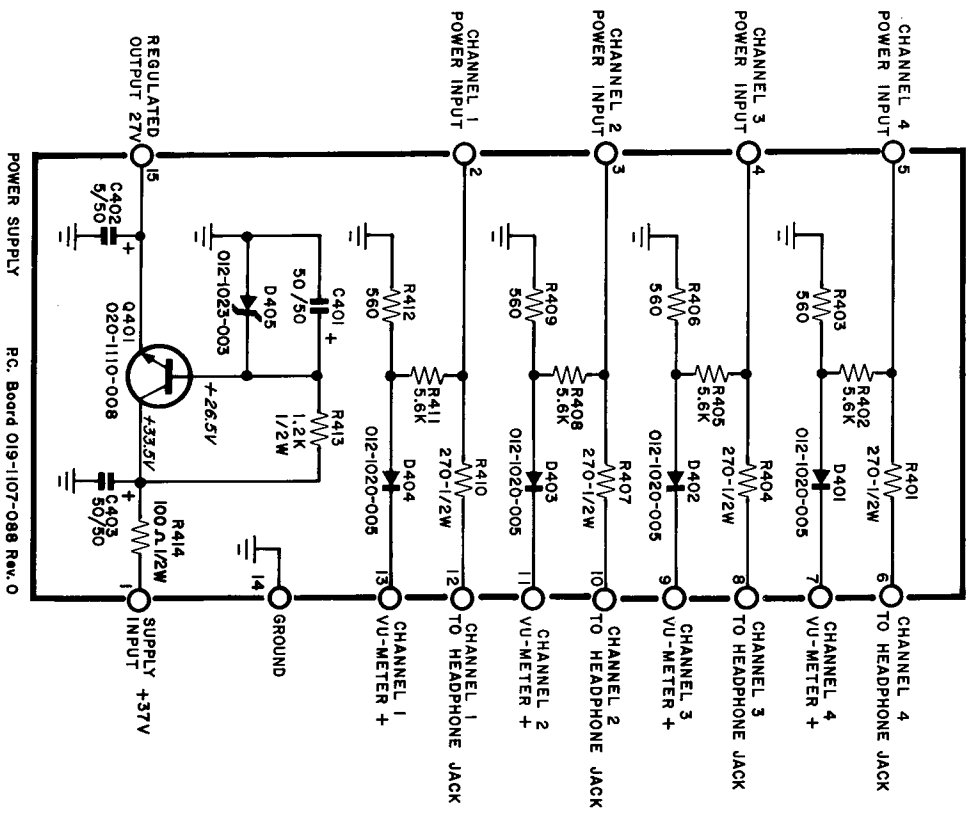

POWER SUPPLY R.C. Board 019-1107-088 Rev. 0

UNLESS OTHERWISE SPECIFIED ALL DIMENSIONS ARE IN INCHES		APPROVED FOR PRODUCTION SGT. 8/18/74 CH. REN ENG. S PROD. PROD MATERIAL:		TOLERANCES ON FRACTIONS: 1/4 DECIMALS: .005 ANGLES: 1/2°	
APPROVED ONLY FOR SAME QUOTE		APPROVED ONLY FOR SAME QUOTE		H. H. SCOTT, INC. MAYNARD, MASS.	
POWER SUPPLY / METER BD. SIZE DWG. 100-1340-015 NO. 6 REV. 0		SCALE: SHEET 1 OF 1 DATE 11-14-69		H. H. SCOTT, INC. POWER SUPPLY / METER BD. SIZE DWG. 100-1340-015 NO. 6 REV. 0	

REVISIONS			
SNL	DESCRIPTION	DATE	APPR.
1	ECO 1702	3-1-67	WJH/MS
2	ECO 1886	8-3-67	WJH/MS
3	ECO 2205	5-13-68	WJH/MS
4	ECO 3336A	5-4-70	WJH/MS

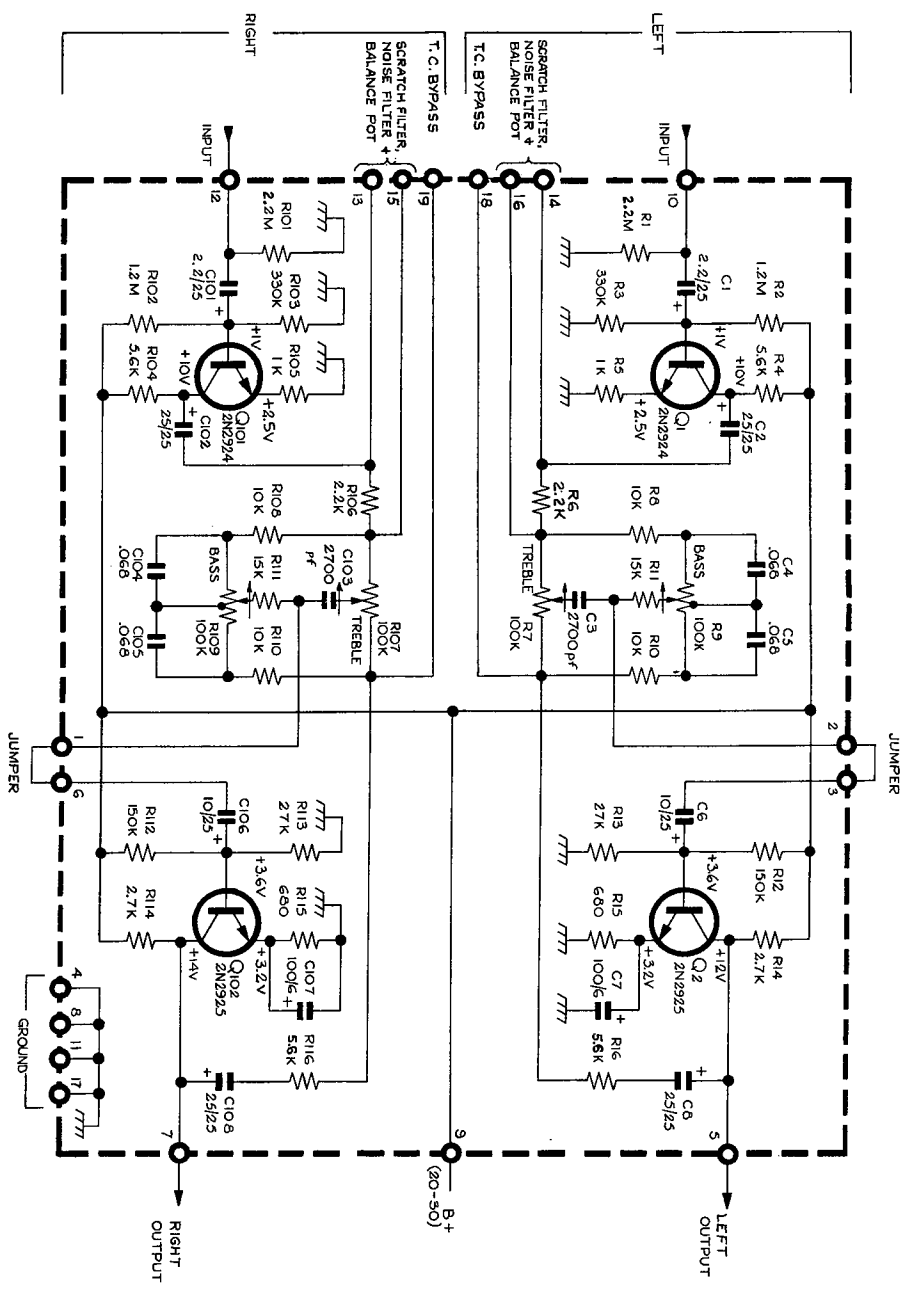

DUAL TONE CONTROL 100-1334-002

PC BOARD 019-1107-016

- NOTES:
- UNLESS OTHERWISE SPECIFIED: RESISTANCE IN OHMS CAPACITORS IN MFD'S RESISTORS 1/2WATT
 - ARROWS ON POTS INDICATE CW ROTATION
 - RIGHT & LEFT CHANNEL BASS CONTROLS ON SAME CONCENTRIC SHAFT
 - RIGHT & LEFT CHANNEL TREBLE CONTROLS ON SAME CONCENTRIC SHAFT
 - UNLESS OTHERWISE SPECIFIED ALL VALVES ARE 6X4 DC 20K A/V VOLT WITH NO SIGNAL APPLIED.

OLD P/N Z-PC-T-2

DATE	8-19-66	H.H.	H.H. SCOTT, INC., MAYNARD, MASS.
DRAGE			
CH		SCALE	CIRCUIT DIAGRAM
ENG. (REV.)	12/9/66	DRWG. SIZE	100-1334-002
PROD.		SHEET - OF -	4

Q2,Q102; 020-1110-013
Q1,Q101; 020-1110-012

CIRCUIT DIAGRAM 100-1334-011

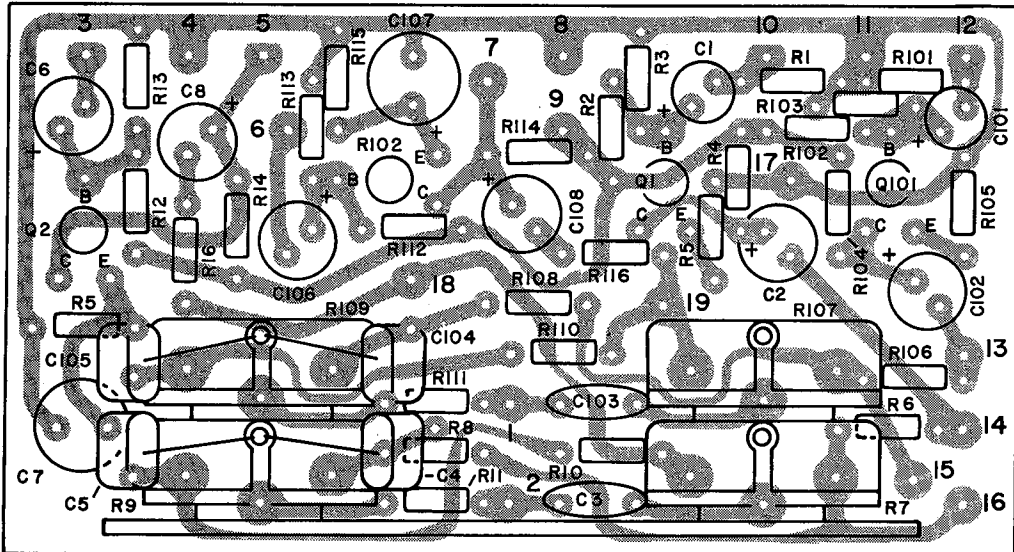

H.H.S DUAL TONE CONTROL

019-1107-016 REV.0

CIRCUIT DIAGRAM 100-1352-003

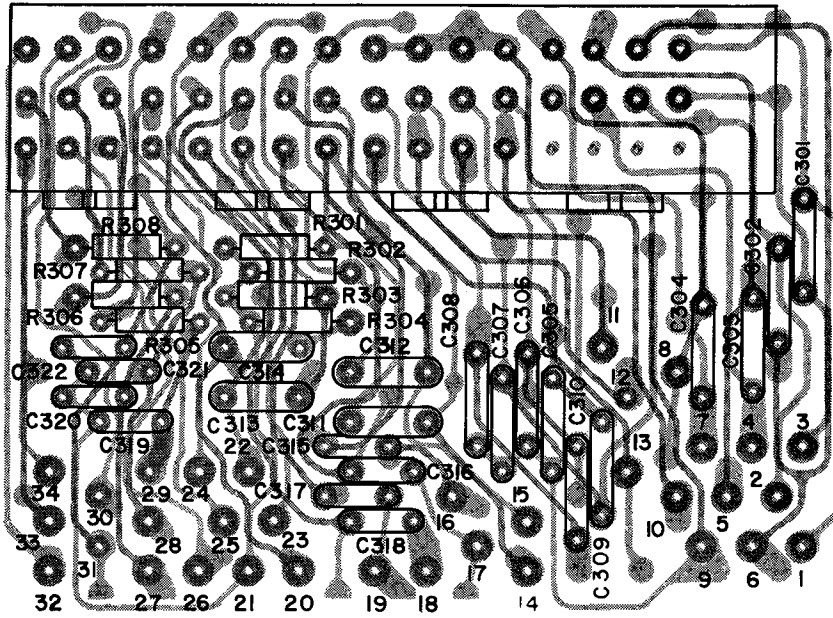

PUSH BUTTON SW.

019-1107-089 REV. I

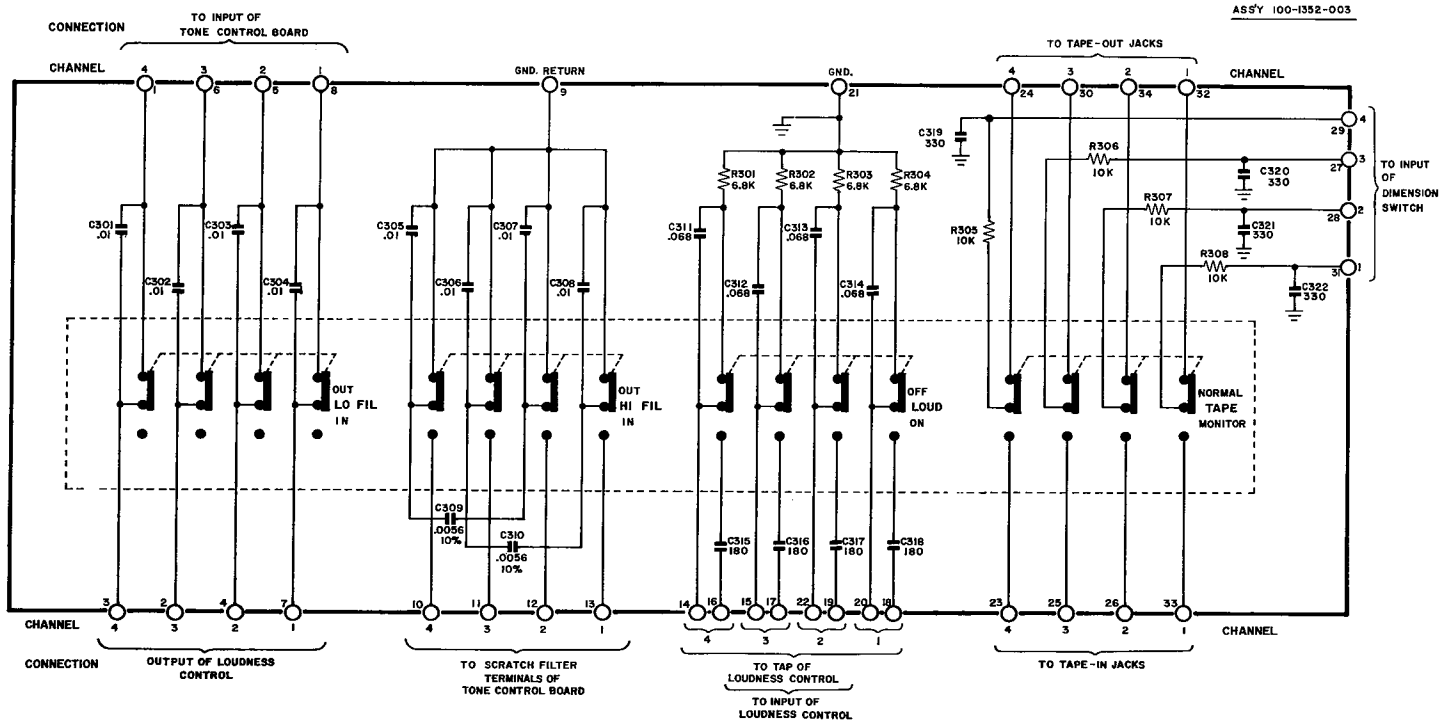

SWITCH BOARD

NOTES:
 1. UNLESS OTHERWISE SPECIFIED; RESISTANCE IN OHMS $\pm 10\%$ 1/4 WATT,
 AND CAPACITANCE IN MFD'S
 2. HIGHEST SERIES NO'S R308, C322

PC BOARD 019-1107-089

Circuit Diagram 100-1333-018 Rev.0

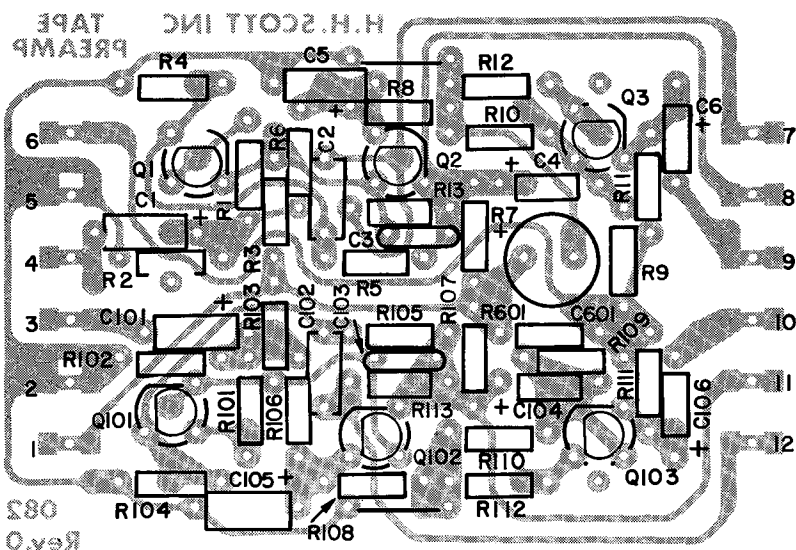

TAPE HEAD PREAMP

019-1107-082 Rev.0

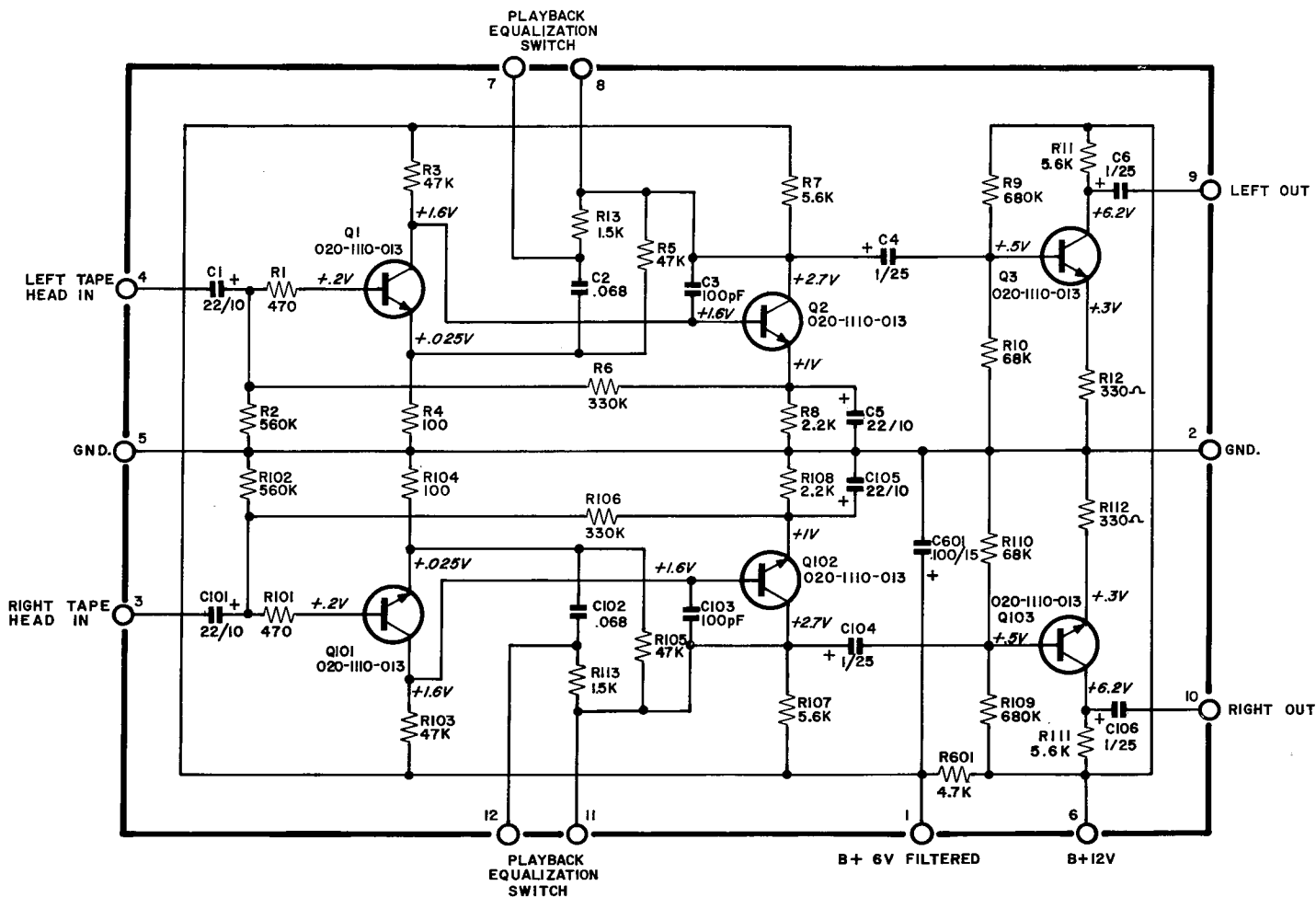

TAPE HEAD PREAMP

PC BOARD 019-1107-082 Rev.0