

ADCOM[®]
details you can hear

GDA-600

Digital-to-Analog
Converter

OWNER'S MANUAL

THE FOLLOWING PRECAUTIONS AND SAFETY INSTRUCTIONS ARE REQUIREMENTS OF UL AND CSA SAFETY REGULATIONS

Warning: To reduce the risk of fire or electric shock, do not expose this unit to rain or moisture.

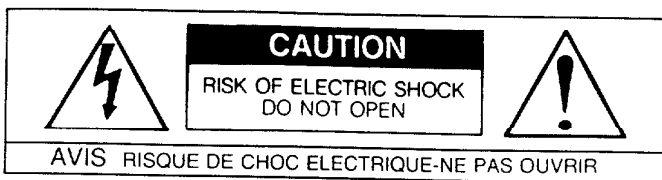

The graphic symbol of a lightning flash with an arrow point within a triangle signifies that there is dangerous voltage within the unit and it poses a hazard to anyone removing the cover to gain access to the interior of the unit **Only qualified service personnel should make any such attempt.**



The graphic symbol of an exclamation point within an equilateral triangle warns a user of the device that it is necessary to refer to the instruction manual and its warnings for proper operation of the unit



Do not place this unit on an unstable cart, stand, tripod, bracket, or table. The unit may fall, causing serious injury to a child or adult, and serious damage to the unit. Use only with a cart, stand, tripod, bracket, or table recommended by the manufacturer, or sold with the unit. Any mounting of the device should follow the manufacturer's instructions, and should use a mounting accessory recommended by the manufacturer.

Read all the safety and operating instructions before connecting or using this unit

Retain this notice and the owner's manual for future reference

All warnings on the unit and in its operating instructions should be adhered to

All operating and use instructions should be followed

Do not use this unit near water for example near a bathtub, washbowl, kitchen sink, laundry tub, in a wet basement, or near a swimming pool

The unit should be installed so that its location or position does not interfere with its proper ventilation. For example, it should not be situated on a bed, sofa, rug, or similar surface that may block the ventilation openings, or placed in a built-in installation, such as bookcase or cabinet, that may impede the flow of air through its ventilation openings

The unit should be situated away from heat sources such as radiators, heat registers, stoves, or other devices (including amplifiers) that produce heat

The unit should be connected to a power-supply outlet only of the voltage and frequency marked on its rear panel

The power-supply cord should be routed so that it is not likely to be walked on or pinched, especially near the plug, convenience receptacles, or where the cord exits from the unit.

Clean unit only as recommended in its instruction manual.

The power-supply cord of the unit should be unplugged from the wall outlet when it is to be unused for a long period of time

Care should be taken so that objects do not fall, and liquids are not spilled into the enclosure through any openings

This unit should be serviced by qualified service personnel when

- A The power cord or the plug has been damaged, or
- B Objects have fallen, or liquid has been spilled, into the unit or
- C The unit has been exposed to rain, or liquids of any kind, or
- D The unit does not appear to operate normally, or exhibits a marked change in performance, or
- E The device has been dropped, or the enclosure damaged

**DO NOT ATTEMPT SERVICING OF THIS UNIT YOURSELF.
REFER SERVICING TO QUALIFIED SERVICE PERSONNEL.**

ATTENTION

POUR PREVENIR LES CHOCS ELECTRIQUES NE PAS UTILISER CETTE FICHE POLARISEE AVFC UN PROLONGATEUR, UNE PRISE DE COURANT OU UNE AUTRE SORTIE DE COURANT, SAUF SI LES LAMES PEUVENT ETRE INSEREES A FOND SANS EN LAISSER AUCUNE PARTIE A DECOUVERT

CAUTION

TO PREVENT ELECTRIC SHOCK DO NOT USE THIS POLARIZED PLUG WITH AN EXTENSION CORD, RECEPTACLE OR OTHER OUTLET UNLESS THE BLADES CAN BE FULLY INSERTED TO PREVENT BLADE EXPOSURE

CAUTION

POWER LINES

Any outdoor antenna must be located away from all power lines

OUTDOOR ANTENNA GROUNDING

If an outside antenna is connected to your tuner or tuner preamplifier, be sure the antenna system is grounded so as to provide some protection against voltage surges and built-up static charges. Section 810 of the National Electrical Code, ANSI/NFPA No. 70-1984, provides information with respect to proper grounding of the mast and supporting structure, grounding of the lead-in wire to an antenna discharge unit, size of grounding conductors, location of antenna discharge unit, connection to grounding electrodes, and requirements for the grounding electrode.

a. Use No.10 AWG (5.3 mm²) copper, No.8 AWG (8.4 mm²) aluminum, No.17 AWG (1.0 mm²) copper-clad steel or bronze wire, or larger, as a ground wire.

b. Secure antenna lead-in and ground wires to house with stand-off insulators spaced from 4-6 feet (1.22-1.83 m) apart.

c. Mount antenna discharge unit as close as possible to where lead-in enters house.

d. Use jumper wire not smaller than No.6 AWG (13.3 mm²) copper, or the equivalent, when a separate antenna-grounding electrode is used. See NEC Section 810-21 (j)

EXAMPLE OF ANTENNA GROUNDING AS PER NATIONAL ELECTRICAL CODE INSTRUCTIONS CONTAINED IN ARTICLE 810 - RADIO AND TELEVISION EQUIPMENT

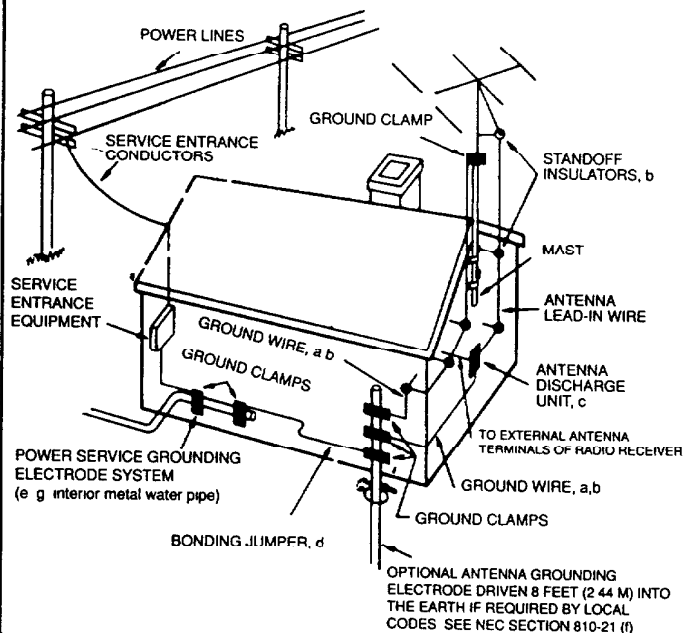

NOTE TO CATV SYSTEM INSTALLER

This reminder is provided to call the CATV system installer's attention to Article 820-22 of the National Electrical Code that provides guidelines for proper grounding and, in particular, specifies that the cable ground shall be connected to the grounding system of the building, as close to the point of cable entry as practical

INTRODUCTION

Congratulations on your decision to purchase the ADCOM GDA-600 Digital-to-Analog Converter. You've made a wise choice that will reward you with years of enjoyment.

When we began the design of the GDA-600, we specified accuracy, musicality, flexibility and cost-effectiveness as the goals of our effort.

The GDA-600 exemplifies the latest refinements in digital signal processing. Jitter reduction and conversion accuracy are addressed in particular. The analog stage benefits from ADCOM's extensive experience and proprietary linear gain amplifiers. The GDA-600 will satisfy both the audiophile and the videophile as it extracts significantly improved sound from any digital source.

In addition, compliance with stringent FCC "Rule 15" regulations assures maximum flexibility for use with a wide variety of home entertainment components.

In short, the GDA-600 is the result of meticulous implementation of proven designs supplemented by careful and extensive listening tests.

Enjoy it! And thank you again for purchasing an ADCOM component.

NOTE: This equipment has been tested and found to comply with the limits for a Class B digital device, pursuant to Part 15 of the FCC (Federal Communication Commission) Rules. These limits are designed to provide reasonable protection against harmful interference in a residential installation. This equipment generates, uses and can radiate radio frequency energy and, if not installed and used in accordance with the instructions, may cause harmful interference to radio communications. However, there is no guarantee that interference will not occur in a particular installation. If this equipment does cause harmful interference to radio or television reception, which can be determined by turning the equipment off and on, the user is encouraged to try to correct the interference by one or more of the following measures.

- 1) Reorient the receiving antenna.
- 2) Increase the separation between the equipment and the receiver.
- 3) Move the computer away from the receiver.
- 4) Connect the equipment into an outlet on a circuit different from that to which the receiver is connected.

Unauthorized circuit changes or modifications may void your right to operate this equipment.

FRONT and REAR PANELS

We carefully designed the GDA-600 with your enjoyment in mind. Take a few moments to familiarize yourself with its front and rear panels. You'll find references to the circled ID numbers throughout the rest of this manual.

GDA-600 FRONT PANEL DIAGRAM

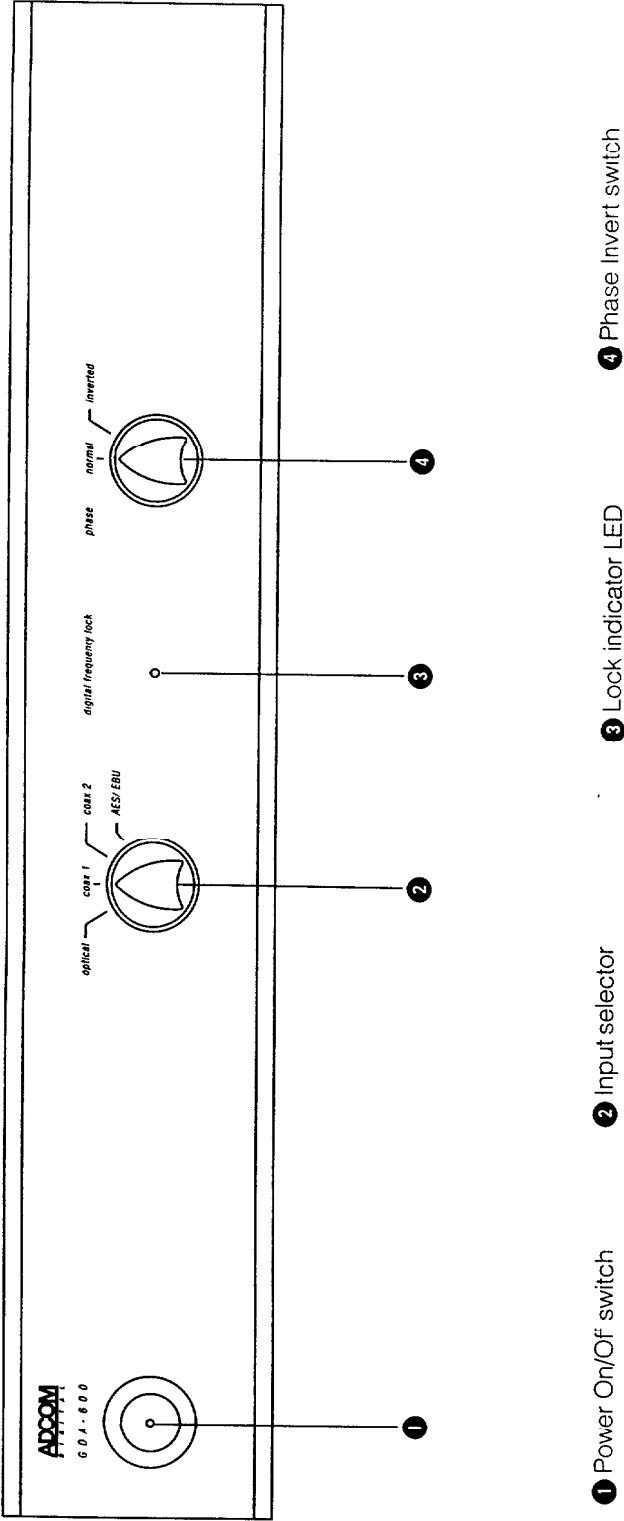

GDA-600 REAR PANEL DIAGRAM

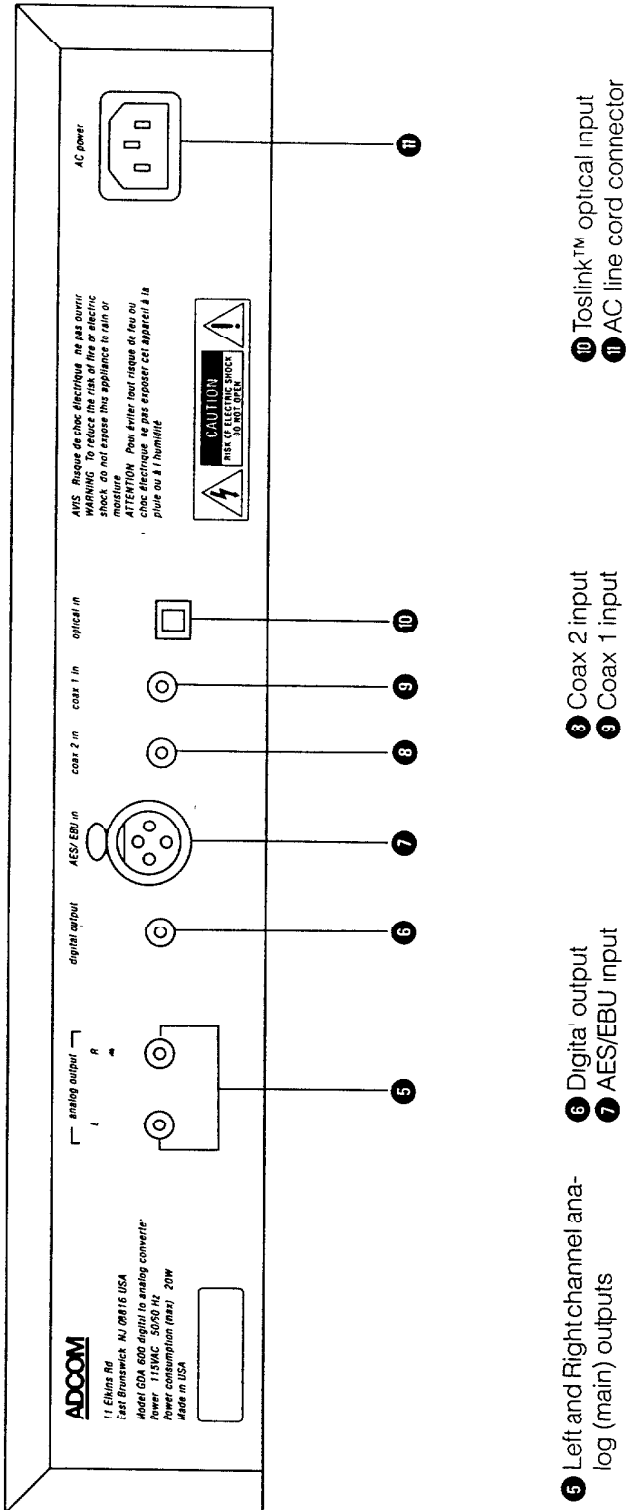

HOOK UP AND OPERATING INSTRUCTIONS

OUT OF THE BOX - - -

- 1) **UNPACKING:** Unpack the GDA-600 carefully. Put the inserts and other packing materials back in the carton and save them if possible.

As part of ADCOM's quality control procedures, your GDA-600 was carefully inspected for physical imperfections and electrical performance before it left our plant. In the event of physical damage, notify your ADCOM dealer immediately and request help in filing a written damage claim.

THE RIGHT TO A CLAIM AGAINST A COMMON CARRIER CAN BE FORFEITED IF THE CARRIER IS NOT NOTIFIED PROMPTLY IN WRITING AND IF THE SHIPPING CARTON AND PACKING MATERIALS ARE NOT AVAILABLE FOR INSPECTION. SAVE ALL PACKING MATERIALS UNTIL THE CLAIM HAS BEEN SETTLED.

The packing and carton were specifically designed to protect your GDA-600. Even though space is often at a premium in today's homes, we recommend that you save the packing materials in case you need to ship the unit anywhere in the future.

- 2) **PLACEMENT:** Select a stable, vibration-free location for the GDA-600 as close as possible to your other audio and video components. The more massive and firmly anchored the supporting surface is, the less likely you'll be to experience any problems.
- 3) **POWER OFF!:** Turn off all system components before initial installation and connection. Remember to give any power amplifiers sufficient time to fully discharge their power supplies before you begin your connections. 30 seconds after turn-off is usually sufficient. And don't plug the GDA-600 into the AC outlet yet.

CONNECTIONS

- 4) **ANALOG OUTPUTS:** Connect the GDA-600's analog (main) outputs **5** to the proper high- or line-level inputs on your system's control center. Remember to connect the left channel output to the left channel input and right to right. Most interconnect cables are color coded to help assure proper channel continuity.

We've received many questions about the sonic attributes of premium interconnect cables. We do suggest that you make sure any cable you use is a "low capacitance" design. (Most are.) Your ADCOM salesperson will be happy to make cost-effective recommendations based on individual component characteristics and system complexity.

- 5) **DIGITAL OUTPUT:** Connect this output to the **digital** input of a digital recording device. Remember that this is a serial digital connection and that both channels of information are carried by one cable.

NOTE: The GDA-600's digital output is an S/PDIF (Sony/Philips Digital Interface Format) output. Although it uses an RCA type jack, it does not have the same characteristics as an analog connection. The S/PDIF format specifies a 75 ohm transmission line and the proper interconnect cable should be specifically designed for 75 ohm data transmission. Standard or even premium grade audio cables usually do not conform to this standard. Although they can be used without fear of damage, they will not provide the reflection-free data path ideal for digital transmissions. "Digital-specific" 75 ohm interconnect cables will result in subtle but very real improvements in musical resolution and detailing. We strongly suggest that you ask your ADCOM dealer for a recommendation.

- 6) **AES/EBU INPUT:** This input **7** conforms to the **A**udio **E**ngineering **S**ociety/**E**uropean **B**roadcast **U**nion standard for professional digital data transmission. It is a premium-grade input with significant electrical and sonic advantages over other digital data formats. ADCOM regards the AES/EBU format as the most desirable high quality digital data path available.

Use this input with any high quality digital source that supports the AES/EBU format. When properly implemented, this input will provide the highest levels of data recovery.

The three pin XLR connector provides a fully shielded transmission path which effectively isolates the digital data from any external interference.

The AES/EBU standard calls for a 110 ohm transmission line. Remember that the interconnect cable is part of this line and should be a "digital-specific" 110 ohm design for minimum signal degradation

Note that the AES/EBU and S/PDIF data transmission standards specify a different line impedance. 110 ohms for AES/EBU and 75 ohms for S/PDIF. Ideally, the interconnect cables for each format should be specifically chosen to adhere to these standards

- 7) **COAX INPUTS (1 & 2)** These RCA style inputs (8 & 9) follow the S/PDIF format. Connect any digital source with an RCA style output to either of these inputs. The NOTE in Section 5 above applies equally here
- 8) **OPTICAL INPUT:** This Toslink™ input 10 is the optical equivalent of the coaxial S/PDIF inputs described in Section 7. It is provided for the convenience of owners of digital sources with a Toslink optical digital output. The Toslink format is found on many consumer CD players and DAT (Digital Audio Tape) recorders as well as videodisc players

Although a few Toslink cables use metal-shielded glass conductors, most use an optical polymer (read plastic) conductor. Treat Toslink cables carefully. Avoid sharp bends or twists when running the cable from your source to the GDA-600 as these can pinch the center conductor and drastically degrade data transmission. Also make sure that the tips of these cables are protected until they are inserted into the Toslink socket of a component. (Most manufacturers supply small plastic shields for this purpose.)

- 9) **AC LINE CORD:** This socket 11 is for the detachable AC line cord and is required by the internal AC filter/surge protector built into the GDA-600. Insert the AC cord into the GDA-600 and plug the other end of the cord into an AC socket

OPERATION

- 10) **VOLUME DOWN — POWER ON!:** Before turning on any system components, make sure that your system's main volume control is turned all the way down. Turn your system components on: sources first, then control center, then power amplifiers.

Turn the GDA-600 on by pressing the Power On/Of switch 1 on the left side of the front panel. The LED in the middle of the switch will light when the GDA-600 is On.

We strongly recommend the use of ADCOM's ACE-515 AC line enhancer/sequential switcher. In addition to providing the convenience and safety of surge protected multiple outlets and dramatically superior RF and EMI filtering, the ACE-515 simplifies system turn-on and turn-off as well. Time delay switching protects your speakers from the potentially annoying effects of power transients. Check with your ADCOM dealer for details.

- 11) **SELECT THE PROPER INPUT:** Use the 4 position **Input Selector** 2 to choose the desired input.
- 12) The **Digital Frequency Lock LED** 3 lights whenever the GDA-600 detects a useable digital source "clock" (or timing signal) at the selected input. This clock signal is not the same as digital audio data as a digital source will generally put out a clock signal whenever it is on. For example, the **Digital Frequency Lock LED** may light when a selected CD transport is turned on even though no CD is playing at the time. Conversely, the LED may not go out when you stop or pause the transport but will go out if you turn the transport off.
- 13) **PHASE INVERT SWITCH:** This switch 4 inverts the phase of the audio signal being processed by the GDA-600. This inversion takes place in the digital domain.

In most cases, leave the switch in its "normal" position. Experimentation with different sources may reveal desirable differences with the switch in the "invert" position.

A full description of the effects of phase inversion is beyond the scope of this manual. Briefly stated, proper phase more naturally reproduces transient information (the initial impact of a percussive sound or a brass fanfare) so as to "sharpen" our overall impression of the music. Phase inversion capability can correct aural problems often caused by processing errors during the original recording session. The GDA-600's phase inversion switch is also useful when other components in the playback system invert phase.

CARE AND FEEDING OF THE GDA-600

ADCOM has taken great care to assure that your GDA-600 is as flawless in appearance as it is electrically. The front panel is a heavy-gauge, high grade anodized aluminum extrusion bead blasted for durability. The chassis, rear panel and top cover are painted and baked heavy gauge steel.

If the outer cover or front panel becomes dusty or fingerprinted, please clean with a soft, lintless cloth SLIGHTLY DAMPENED with a very mild detergent solution.

DO NOT SPRAY OR USE LIQUIDS OF ANY KIND ON YOUR UNIT!

NEVER USE HARSH SCOURING POWDERS!

SERVICING

ADCOM's Customer Service Department will be happy to answer all questions pertaining to the installation and operation of your unit. In the unlikely event of difficulty, please contact us for prompt advice. If we can't help you resolve the problem immediately, we may refer you to an authorized repair agency, or authorize the return of your unit to our plant.

All written inquiries should be addressed to

ADCOM Service Department
11 Elkins Road
East Brunswick, NJ 08816
USA

Telephone inquiries are welcomed from Monday through Friday between 9 AM and 4 PM, Eastern Time.

Please call (908) 390-1130

We'll also be happy to answer FAX inquiries sent to (908) 390-9152. Please include your phone and FAX numbers so we can respond.

When inquiring about your unit, please include the serial number, the name of the dealer from whom you purchased the unit and the date of purchase.

If we ask you to return the unit to us for service, we will issue a specific Return Authorization number for your use. UNDER NO CIRCUMSTANCES SHOULD THE UNIT BE SHIPPED TO US WITHOUT PROPER AUTHORIZATION OR PACKED IN ANYTHING OTHER THAN ITS ORIGINAL PACKING.

If the original packing has been lost, discarded or damaged, we will be happy to supply a replacement at a nominal charge. Please mention your need when you call or write.

Always ship PREPAID via UPS (United Parcel Service) or other appropriate carrier. FREIGHT COLLECT SHIPMENTS WILL BE REFUSED.

DO NOT SHIP VIA PARCEL POST as the packaging may not withstand handling by our Postal Service.

GDA-600 SPECIFICATIONS

Digital

Input format	S/PDIF, AES/EBU
Input type	S/PDIF Coax (RCA x 2) S/PDIF Optical (Toslink™ x 1) AES/EBU (XLR x 1)
Input isolation	Transformer coupled
Input decoding	Crystal CS 8412 receiver
Digital output	S/PDIF Coax (RCA x 1)
Digital filter	Burr-Brown Linear Phase
Resampling rate	8x (352.8 kHz for 44.1 kHz input)
DAC type	Selected R-2R Burr-Brown PCM-63
Resolution	20 bits
Phase inversion	Digital domain (manual selection)

Analog

Frequency response	DC - 20 kHz +0, -0.5dB
THD	0.009% (20 Hz - 20 kHz, full scale) 0.002% (1 kHz, full scale)
Signal to noise ratio	106 dB (20 Hz - 20 kHz, unweighted) ≥112 dB (20 Hz - 20 kHz, "A" wtg.)
Dynamic range	98 dB
Channel-to-channel crosstalk	106 dB (20 Hz - 20 kHz) 112 dB (1 kHz)
Output voltage	2.234 V RMS (full scale)
Output impedance	77 ohms
Output type	Single ended (RCA x 2)
Output mute	Relay activated (Power, Unlock)

General

Power requirements	97 - 132 VAC, 50/60 Hz 220 - 240 VAC, 50/60 Hz
Power consumption (nominal)	15 watts @ 120 VAC
Fuse	3/8 amp, Slow blow
Dimensions	17" W x 3 1/4" H x 10 1/2" D
Shipping weight	12 lb

ADCOM
11 Elkins road
East Brunswick, NJ 08816 U S A
Telephone (908) 390-1130
Fax (908) 390 9152