



LB 1002

RTX G TRU-2

A dynamic high capacity Carpigiani machine allows you to create both high and low overrun frozen products such as Ice Cream, Gelato, Sorbet, Sherbet, Custard, Water Ice and more..Ideal for high volume Ice Cream production.



Performance and Quality Patented Hard-O-Dynamic technology achieves desired consistency with any batch size. Electronic controls automatically maintain product until extraction begins. Beater resists extreme hot and cold temperatures and includes auto-adjusting scrapers for complete extraction. Includes separate Ice Cream and Gelato beaters for both high & low overrun Frozen Desserts.



Convenience Automatic Control provides unparalleled flexibility and ease of operation. Audible alarm signals when product achieves desired consistency. Maximized extraction results in minimal flavor overlap with less frequent rinsing. Optional shelf mat designed to hold trays & tubs during extraction.



Savings Lowest power consumption in the industry while providing some of the quickest batch freezing times. Self-adjusting scraper can be replaced without needing a new beater. Air-cooling option available.



Safety Automatic defrost starts during power outages to avoid damage to beater. Rounded corners reduce risk of injury to operator. Operations are done standing up for user comfort.



Hygiene Built-in faucet with flex hose makes cleaning fast and easy. Removable extraction chute for easy cleaning. Scotch-Brite treated steel is resistant to stains and fat residues. Ask your Carpigiani Sales Representative for the "Carpi Care Kit" to best maintain equipment.



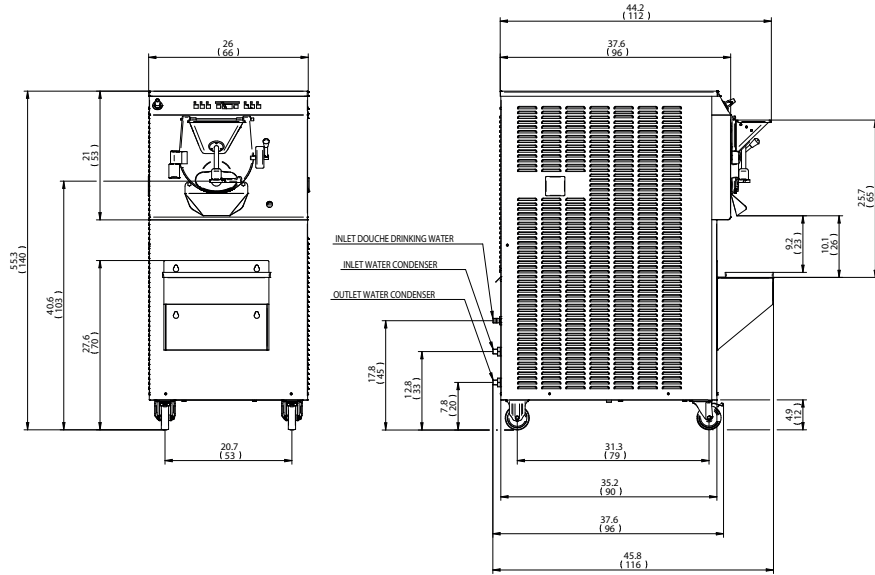

WATER

Weights	lbs.	kgs.	
Net	992	450	
Crated	1135	515	
Volume	cu. ft.	cu. m.	
Volume	64.6	1.83	
Dimensions	in.	cm.	
Width	26	66	
Depth	45.8	116	
Height	55.3	140	
Electrical	Maximum Fuse Size	Minimum Circuit Ampacity	Poles (P) Wires (W)
208-230/60/3 Water	80A	57A	3P, 3W

Specifications

Electrical

A dedicated electrical connection is required. Manufactured to be permanently connected. See the Electrical chart for the proper electrical requirements. Consult your local Carpigiani distributor for cord & receptacle specifications as local codes allow.

Beater Motor

5/10 HP

Refrigeration System

R404A

Water Cooled

Water inlets and drain connections in the rear 1/2" MPT

Cylinder Capacity

37 quarts (35 liters)

All specifications mentioned must be considered approximate; Carpigiani reserves the right to modify, without notice, all parts deemed necessary. This unit may be manufactured in other electrical characteristics and may have additional regulatory agency approvals, please consult the local Carpigiani Distributor. Check name plate for exact electrical data. * Room temperature 68 °F (20 °C).

Bidding Specs

Electrical Volt _____ Hz _____ Ph _____ Neutral _____ Yes No Cooling Air Water

Options _____



Dealer



www.bipiuci.it | printed 06/2021

an Ali Group Company



The Spirit of Excellence