



# XVL 3

P

Advanced Pump-fed floor standing twist Soft Serve Model for Ice Cream, Custard and plant based recipes.



**Performance and Quality** The Carpigiani reputation for the smoothest, creamiest soft serve in the market is proven with this powerful, versatile model. Hopper mixer accommodates any type of mix with high level of solids or water. Each side can independently accommodate different overrun and mixtures with diverse textures such as custard or yogurt one side and Sorbet on the other.



**Convenience** Hopper mixer easily snaps into place. Audible Signal alerts when refill is needed.



**Savings** Unique cylinder construction delivers better results using less electricity. Independent cylinders allow one side to be turned off saving power during low season. Water-cooled & Air Cooled versions available.



**Safety** TEOREMA guarantees facilitated assistance by providing on-line monitoring and diagnosis on a tablet, phone or PC wherever you are.



**Hygiene** Unique patented heat cleaning cycle option allows for faster and easier cleaning with less water waste. Standby mode maintains safe product temperatures in the freezing cylinder and mix hopper utilizing minimal energy during idle periods.



\*request the kits from your distributor to maintain your machine hygienically clean.

[carpigiani.com/us](http://carpigiani.com/us)

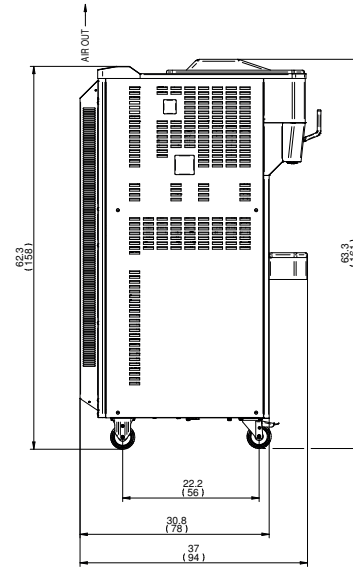
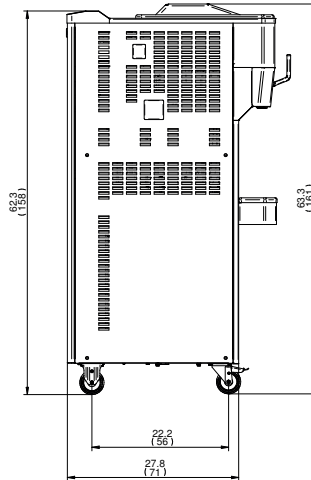
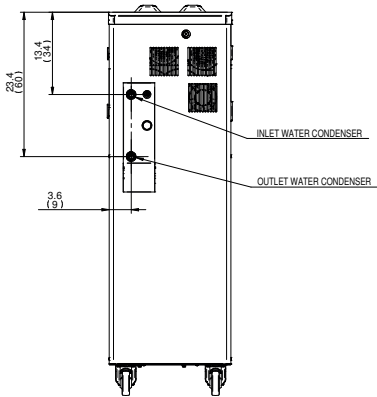

	WATER		AIR	
Weights	lbs.	kgs.	lbs.	kgs.
Net	683	310	683	310
Crated	749	340	751	341
	cu. ft.	cu. m.	cu. ft.	cu. m.
Volume	50.15	1.42	50.15	1.42
Dimensions	in.	cm.	in.	cm.
Width	20	51	20	51
Depth	34.1	87	37	94
Height	63.3	161	63.3	161
Electrical	Maximum Fuse Size	Minimum Circuit Ampacity	Poles (P) Wires (W)	
208-230/60/3 Water	35A	35A	3P, 3W	
208-230/60/3 Air	35A	35A	3P, 3W	

## Specifications

### Electrical

A dedicated electrical connection is required. Manufactured to be permanently connected. See the Electrical chart for the proper electrical requirements. Consult your local Carpigiani distributor for cord & receptacle specifications as local codes allow.

### Beater Motor

1,5 HP + 1,5 HP

### Refrigeration System

R449A

### Water Cooled

Water inlets and drain connections in the rear 1/2" MPT

### Air Cooled \*

Minimum clearance: 4" (10 cm) on both side panels and 0" (0 cm) from the rear panel for proper air circulation.

### Hopper Capacity

13.7 + 13.7 quarts (13 + 13 liters)

All specifications mentioned must be considered approximate; Carpigiani reserves the right to modify, without notice, all parts deemed necessary. This unit may be manufactured in other electrical characteristics and may have additional regulatory agency approvals, please consult the local Carpigiani Distributor. Check name plate for exact electrical data. \* Room temperature 68 °F (20 °C).

### Bidding Specs

Electrical Volt \_\_\_\_\_ Hz \_\_\_\_\_ Ph \_\_\_\_\_ Neutral  Yes  No Cooling  Air  Water

Options \_\_\_\_\_



738 Gallimore Dairy Road, Suite 113  
High Point, NC - 27265  
Toll free (800) 648 4389



Dealer

an Ali Group Company



The Spirit of Excellence