



Project:

Item Number:

Quantity:

F231-2X GRAVITY FED TWIN TWIST FLOOR MODEL WITH LARGE CAPACITY HOPPER



DESCRIPTION

Stoelting's Gravity Soft Serve Freezer dispenses two single flavors, or combines them in a twin twist. The F231-2X has 66% larger storage capacity than the standard F231. Each hopper can hold up to five gallons of mix.

This freezer is ideal in self-serve and buffet-style restaurants or any location seeking the convenience of less frequent hopper refills.

ITEMS

- F231-3812-2X** Air-Cooled, Single Phase
- F231-30912-2X** Air-Cooled, Three Phase

FEATURES

- NSF approved food grade plastic blades provide quiet operation and superior durability.
- Simplified design for quick assembly after cleaning.
- Adjust the dispense rate to meet your requirements.
- Clear door displays circulating product for merchandising appeal.
- Efficient freezing cylinder and auger design delivers a consistent uniform product with small ice crystals and a quick recovery time.
- Highly efficient auger design gently folds the entire contents of the freezing cylinder, delivering a thick, smooth, and creamy product.
- Self-closing spigot eliminates waste and ensures precise portion control.
- Long-wearing parts offer lower preventative maintenance costs.
- Organized hopper covers have compartments for all parts in the freezing cylinder. The hopper covers help with parts identification and prevent loss of parts.

IntelliTec™ Control

- Programmable and configurable through multi-line graphics display.
- Upload firmware and download statistics through a USB connection.
- Performance and error logs provide data to maximize profitability.
- Senses product consistency or temperature to customize for a wide variety of mixes.
- Standby and sleep modes conserve energy and automatically defrost product, maintaining small ice crystals and delivering a superior mouthfeel.

ADA Compliant Handles

- Flat handles 48" from ground.



Every machine includes Stoelting's White Glove Service. One call does it all – customer service, technical service, parts or warranty information, installation ,startup, sales, on-site service dispatch and much more. Available 24 hours a day, seven days a week year-round.

Continuous research leads to ongoing product improvements; therefore, these specifications are subject to change without notice and should not be used as installation specifications.

Approvals	Date

F231-2X GRAVITY FED TWIN TWIST FLOOR MODEL WITH LARGE CAPACITY HOPPER

DIMENSIONS

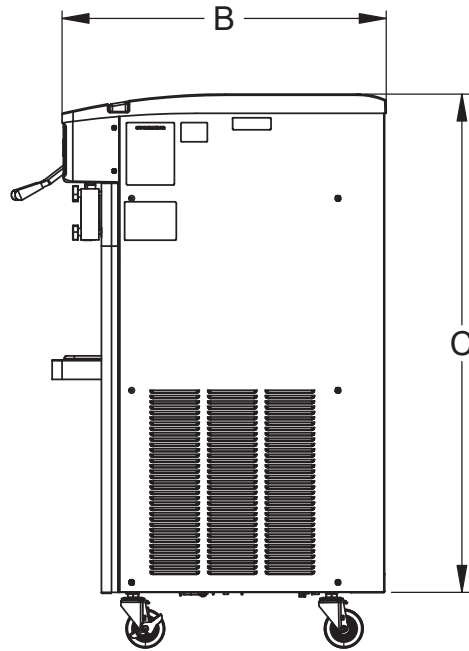
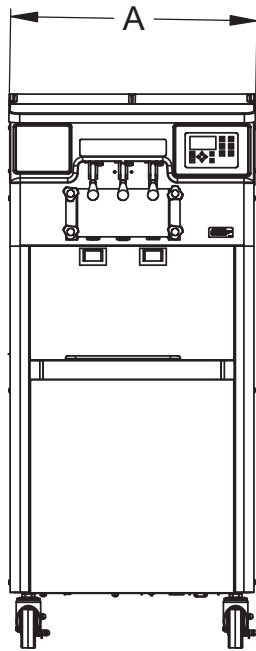

GENERAL SPECIFICATIONS

Model	Freezing Cylinder			Drive Motor (hp)	Hopper			Weight lb (kg)	Crated Weight lb (kg)	Dimensions - in (cm)		
	Capacity gallon (L)	Compressor Btu/hr	Refrigerant		Capacity gallon (L)	Compressor Btu/hr	Refrigerant			(A) Width	(C) Height	(B) Depth
F231-38I2-2X	Two 0.85 (3.22)	12,000	R-404A	Two 3/4	Two 5 (18.9)	1,300	R-134a	640 (290.2)	730 (331.1)	25-5/8 (65.2)	57-3/4 (146.5)	33-3/4 (85.8)
F231-309I2-2X		19,500										

- Requires a dedicated electrical circuit.
- Indoor use only.
- Maximum ambient temperature: 100°F (37.8°C)
- Air cooled units require 3" (7.6 cm) air space on both sides.

ITEM NUMBER SPECIFICATIONS

Item Number	Cooling	Volts	Phase	Hz	Running Amps	Cord with Plug (Included)
F231-38I2-2X	Air	208-240	1	60	13.52	NEMA 6-20P
F231-309I2-2X			3		11.52	NEMA L15-20P