



Model M202A (Ser. #0 - #25244)
OPERATORS MANUAL

Manual No. [513614](#)

Rev.5

This manual provides basic information about the machine. Instructions and suggestions are given covering its operation and care.

The illustrations and specifications are not binding in detail. We reserve the right to make changes to the machine without notice, and without incurring any obligation to modify or provide new parts for machines built prior to date of change.

DO NOT ATTEMPT to operate the machine until instructions and safety precautions in this manual are read completely and are thoroughly understood. If problems develop or questions arise in connection with installation, operation, or servicing of the machine, contact Stoelting.



stoeltingfoodservice.com

Stoelting Foodservice Equipment
502 Highway 67
Kiel, WI 53042-1600
U.S.A.

Main Tel: 800.558.5807
Fax: 920.894.7029

Customer Service: 888.429.5920
Fax: 800.545.0662
Email: foodservice@stoelting.com

© 2014 PW Stoelting, LLC

A Few Words About Safety

Safety Information

Read and understand the entire manual before operating or maintaining Stoelting equipment.

This manual provides the operator with information for the safe operation and maintenance of Stoelting equipment. As with any machine, there are hazards associated with their operation. For this reason safety is emphasized throughout the manual. To highlight specific safety information, the following safety definitions are provided to assist the reader.

The purpose of safety symbols is to attract your attention to possible dangers. The safety symbols, and their explanations, deserve your careful attention and understanding. The safety warnings do not by themselves eliminate any danger. The instructions or warnings they give are not substitutes for proper accident prevention measures.

If you need to replace a part, use genuine Stoelting parts with the correct part number or an equivalent part. We strongly recommend that you do not use replacement parts of inferior quality.



Safety Alert Symbol:

This symbol Indicates danger, warning or caution. Attention is required in order to avoid serious personal injury. The message that follows the symbol contains important information about safety.

Signal Word:

Signal words are distinctive words used throughout this manual that alert the reader to the existence and relative degree of a hazard.



The signal word "WARNING" indicates a potentially hazardous situation, which, if not avoided, may result in death or serious injury and equipment/property damage.



The signal word "CAUTION" indicates a potentially hazardous situation, which, if not avoided, may result in minor or moderate injury and equipment/property damage.

CAUTION

The signal word "CAUTION" not preceded by the safety alert symbol indicates a potentially hazardous situation, which, if not avoided, may result in equipment/property damage.

NOTE (or NOTICE)

The signal word "NOTICE" indicates information or procedures that relate directly or indirectly to the safety of personnel or equipment/property.

SAFETY WARNING:

Do not attempt to assemble or take apart any parts of the machine without making sure the refrigeration and beater switches are in the “OFF” position and the keys are removed. Serious bodily injury may result.

IMPORTANT:

In order to eliminate the custard machine as a source of bacterial contamination, it is extremely important that the following instructions be followed exactly each time the machine is disassembled for cleaning as part of nightly shutdown procedures. Ross’s makes no warranties expressed or implied as to the introduction of bacteria or other pathogens into the custard mix run through the machine. It is beyond the scope of this manual to address proper mix handling procedures.

WARNING:

NEVER USE HOT WATER ANYWHERE INSIDE MACHINE.

Standard Parts included per machine

- 1 Each Dipping Water Trough, Part #DT-0020
- 1 Each Splash Guard, Part #C-4000-14
- 4 Each Dividers for dipping well, Part #C-5000-20
- 1 Each Beater Shaft Wrench, Part #C-2000-57
- 1 Each Barrel Cleaning Brush, Part #BR-0030
- 1 Each Barrel Brush Handle, Part #BR-0035
- 4 Each 6” Casters (Standard on Water Cooled Units)
- 4 Each 6” Adjustable, Stainless Steel, Legs (Std. on Air Cooled Units)
- 1 Each Operating Manual

Not Pictured:
 Divider for Water Trough
 Barrel Brush
 Petrol-gel
 Operating Manual
 Back Seal Washer

Standard Parts included with machine, per barrel

- 1 Each Short Slide (chute), Part #C-4000-20
- 1 Each Flow Valve Assembly, Part #C-9000-58
- 1 Each Flow Control Rod, Part #C-9000-80-SV
- 1 Each Front Plate, Part #C-2000-52-SV
- 1 Each Front Gate, Part #C-2000-56
- 1 Each Beater Shaft, Part #C-9000-51
- 4 Each Wing Nuts, Part #NT-0010
- 1 Set of 8 Blades, Part #C-2000-51
- 1 Set of 8 Springs, Part #C-2000-50
- 1 Each Large O-rings, Part #624782 (for Front Plate)
- 1 Each Rear Shaft Seal, Part #SL-0010
- 1 Each Key

Extra Parts included per machine:

- 2 Each Blade, Part #C-2000-51
- 2 Each Spring, Part #C-2000-50
- 2 Each Large O-rings, Part #RG-0010 (for Front Plate)
- 2 Each Rear Shaft Seal, Part #SL-0010
- 2 Each Keys

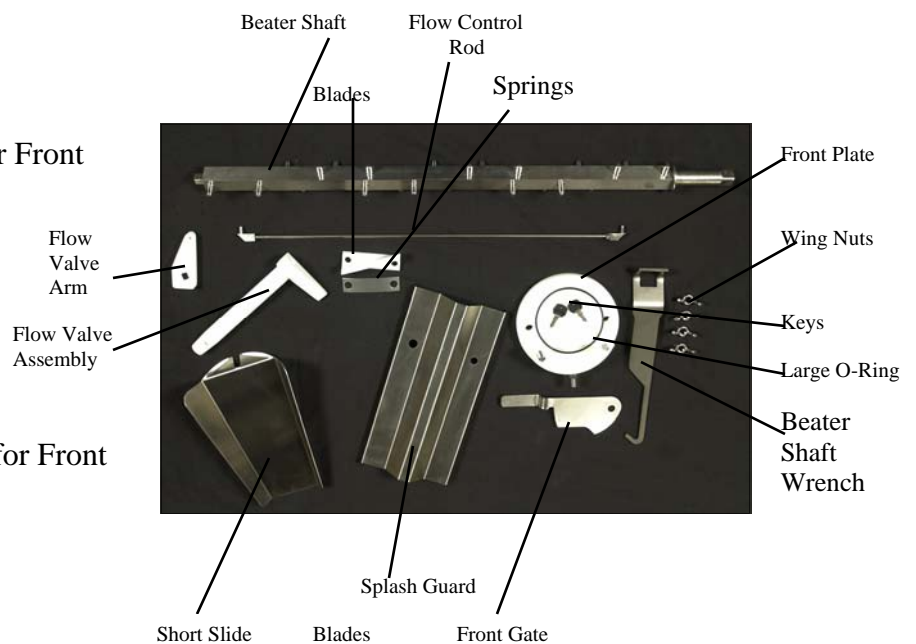

ASSEMBLY/SANITIZING

A. Initial Start

1. Make sure the refrigeration and beater switches on the front of the machine are turned "OFF" and the beater key is removed.



B. Flow Control Valve Assembly and Insertion

1. Place the white plastic flow valve in the hopper pan drain hole. Tapered portion of the tube to be inserted in the drain tube hole.
2. Place the flow valve arm on the square flow valve drive which is located at the front of the hopper pan.
3. Place one end of the flow control rod in the small hole located on the flow valve and place the other end of the rod in the small hole on the flow valve arm.
4. To adjust the flow control, turn the flow control knob clockwise to increase the flow and turn counter clockwise to decrease the flow.



C. Beater Shaft and Blade Assembly

1. Coat the rear gasket with a small amount of Petrol Gel. Place the rear gasket on the beater shaft. The gasket should be placed over the hex cut end and pushed over the round portion of the shaft until it bumps against the square of the shaft. Put a small amount of Hex Drive Anti Seize on the hex end of the beater shaft.



2. Starting on the end of the beater shaft with the square tip, place a metal spring (arched upward) over the two pins closest to the end. Place a blade on top of the spring.



3. With the spring and blade in place, slide the beater shaft into the barrel several inches with the blade facing down.



4. Put a spring and blade on the next set of pins. Push the beater shaft further into the barrel just far enough to hold the blade in place on the shaft. As you push, turn the beater shaft so the next set of pins is facing up. You will have to squeeze the blade and spring against the beater shaft in order to push the shaft into the barrel.



5. Continue adding springs and blades to the beater shaft until all 12 blades are installed. It may get more difficult to push the beater shaft into the barrel as you add springs and blades.
6. Using the beater shaft wrench, push and turn the beater shaft until it engages the drive coupling in the back of the machine. When the beater shaft engages, it will move approximately one inch further into the barrel. It will not be able to move back any further. At this point, the entire shaft assembly will be inside the barrel.



ASSEMBLY/SANITIZING

7. Install the large o-ring on the front plate .
8. Put a small amount of Petrol Gel on the inside and outside of the front bushing and install the bushing onto the end of the beater shaft.



9. Slide the front plate over the threaded studs on the front of the barrel with the front plate's hole in the bottom position. The rear of the front plate should be tight against the front of the barrel. If not, the beater shaft was not installed correctly. If the front plate is tight against the barrel, use two wing nuts to secure it in place. Tighten the wing nuts securely.



10. Slide the front gate over the threaded stud so the gate handle rests on the gate peg. If the front gate is installed properly, it will cover the custard outlet completely. Secure the front gate and safety guard with a wing nut on the threaded stud.



11. Repeat the assembly instructions on the remaining barrel(s).

D. Sanitizing

1. Put the beater key into the beater switch. Before sanitizing, make sure the refrigeration switch on the front of the machine is turned "OFF"; the front control knob is to be in the "OFF" position.



2. Remove the front gate and replace with splashguard. Secure with wing nut. The splashguard directs the water into the dipping trough.



3. Pour one to two gallons (four to eight liters) of approved sanitizer into the hopper pan. The solution should be cold. Do not exceed 100° Fahrenheit (38° Celsius).

4. Wash the sides of the hopper pan and the inside of the hopper pan cover with a clean towel saturated with the sanitized solution.

5. Turn the flow knob to position number "2" to allow sanitizer to lubricate the barrel. After one or two seconds, turn the beater switch on.



6. The sanitizer will flush through the barrel, against the splashguard and into the dipping well. (Note: Follow the manufacturer's sanitizing instructions for proper surface contact and time requirement.)

7. After all of the sanitizer has run through the barrel, turn "OFF" the beater switch and turn the flow control to the off position. Remove the splashguard and replace with the front gate. Close the front gate.



8. Repeat the process on the remaining barrel(s). The machine is now ready to operate.

MACHINE OPERATION

A. System Startup

1. Verify that the flow control knob, the refrigeration, and beater switches are in the “OFF” positions.



2. Turn on the Hopper Refrigeration.
3. Pour mix into the hopper pan. (Note: If using rerun mix, use at least 50% fresh mix to 50% rerun mix.)
4. Turn the beater switch “ON”.
5. Turn the flow control knob to the number “1 1/2” for approximately 3 seconds. Turn the knob back to the “OFF” position. This allows custard to mix to flush the sanitizer from the barrel to avoid instant freezing of the sanitizer in the barrel.
6. Place the custard slide on the threaded stud beneath the front plate and secure firmly with a wing nut. Aim the custard slide into a dipping cabinet or other suitable container for dipping.
7. Open the front gate.
8. Within several seconds, a few ounces of liquid mix and sanitizer will flow out of the custard outlet and into the dipping well. Discard this mix.
9. Turn the refrigeration switch on and wait approximately 2 minutes for a chatter noise.



10. Set the flow control knob to “1/2-1” position until frozen custard is seen at the custard outlet. Increase the mix by turning the flow control knob to gain the desired custard texture.



Note: If a “growling” noise comes from the machine during this procedure, it may be an indication that there is not enough mix entering the barrel. Increase the flow slightly by adjusting the flow control knob on the front of the machine. Keep in mind that there are several minutes lag time between the increased mix flow and the elimination of any “growling” noises.

11. Continue to run the mix into the bucket until it reaches the desired quantity.

B. Hold Cycle During Operation

1. Adjust the flow control knob to the “OFF” position. Wait approximately 1 minute.
2. Turn the refrigeration switch to the “Hold”.
3. When the frozen custard stops flowing, turn the beater switch to the “OFF” position and REMOVE KEY. Note: This should take approximately 2 minutes.
4. Clean out excess frozen custard from the custard outlet on the front plate to prevent dripping.
5. Replace key.
6. Close the front gate.
7. Remove custard slide.

C. Resuming Production During Operation

1. Turn the beater switch “ON”.
2. Turn the refrigeration switch “ON”.
3. Wait for a chatter noise, approximately 1 minute. Turn the flow control knob to the number “1-1 1/2” position.
4. Open the front gate completely.
5. When the custard appears, adjust the flow control knob to gain the desired custard texture.
6. Continue to run the mix into the dipping cabinet until you have the amount that you need.



MACHINE OPERATION

D. Preparing for Shutdown (hopper empty)

Removal of Remaining Custard in the Barrel when no mix is in the Hopper

1. Turn refrigeration switch to “Off”
2. Let machine rest for approx. 20 minutes. This allows the barrel enough time to warm before removing remaining custard.
3. Turn the beater switch is “ON”.
4. Run remaining custard through the barrel.
5. Turn the beater switch to “OFF” position.
6. Close the front gate and remove the custard slide.

E. Preparing for Shutdown (mix in hopper)

Removal of Remaining Custard in the Barrel when mix is still in the Hopper

1. Turn “OFF” the refrigeration switch.
2. Let machine rest for approx. 20 minutes. This allows the barrel enough time to warm before draining the remaining mix from the hopper.
3. Take a sanitized bucket and place it at the opening of the front plate.
4. Turn the flow control to “4”. This allows the mix to drain into the barrel and then to your sanitized bucket.

IMPORTANT: In order to eliminate the custard machine as a source of bacterial contamination, it is extremely important that the following instructions be followed exactly each time the machine is disassembled for cleaning as part of nightly shutdown procedures. Ross’s makes no warranties expressed or implied as to the introduction of bacteria or other pathogens into the custard mix run through the machine. It is beyond the scope of this manual to address proper mix handling procedures.

CLEANING AND DISASSEMBLY

A. Cleaning

1. Remove the front gate and install the splashguard.
2. Make a cleaning solution of 1½ to 2 gallons (4-8 liters) of cold water and the correct amount of cleaning solution. Do not exceed 100 degrees Fahrenheit (38 degrees Celsius).
3. Pour the cleaning solution into the hopper pan. Wash down the sides and bottom of the hopper pan to dilute remaining mix.
4. Turn the flow control valve to the number “2” position to allow sanitizer into the barrel.
5. Turn the beater switch to “ON” and run the cleaning solution through the barrel.

Make sure the refrigeration switch is in the “OFF” position.

6. Repeat the procedure until all mix residue is gone and the hopper pan is clean.
7. Turn the beater switch to the “OFF” position and remove the key.
8. Properly dispose of the cleaning solution.

SAFETY WARNING: Do not attempt to remove the front plate, or beater shaft without first removing the key from the beater switch. Serious bodily injury may result.

B. Disassembly

1. Remove key
2. Remove the front gate and front plate for washing. Remove the o-ring from the front plate. Remove front bushing from beater shaft.



3. Lay the washed parts out on a sanitized counter for air drying. With the beater shaft wrench, pull the beater shaft partially out of the barrel by grabbing behind the first blade. Continue to pull the beater shaft forward and remove each blade and spring and place in a container for cleaning.



CAUTION: Be careful not to scratch the inside of the barrel with the beater shaft.

4. Remove the Rear Gasket and wipe the lubricant off the hex end of the beater with a clean towel.



5. Remove the flow control rod and the flow control valve assembly.



6. Take all parts to the cleaning area for washing. Add sufficient hot water and cleaning solution to cover all of the parts. Let soak for five minutes. Make sure mix is removed from all small, hard to clean areas of the parts, including o-ring grooves.
7. While the parts are soaking, use a cleaning solution and barrel brush to clean inside barrel.

8. Wrap a clean towel soaked with cleaning solution around a barrel brush and run the brush and towel through the barrel until it is clean.



CLEANING AND DISASSEMBLY

9. Make sure to clean the drip pan that is located at the rear of the machine in the access panel. Clean out any custard in the pan.



IMPORTANT: Failure to follow these cleaning procedures exactly, each and every night, may result in eventual bacterial contamination of the frozen custard product and health and legal problems for the purchaser of this equipment and the restaurant patrons

10. Clean the front mounting plates with a towel.
11. Clean the sheet metal on the entire machine. Use stainless cleaner and polish on the sheet metal to maintain the machine's appearance. Do not use stainless cleaner on areas where mix or frozen custard is used.
12. Return to the sink and wash each part. Place in a rinse tank and then a sanitizing tank with a proper dilution of an approved sanitizer.

NEVER USE
HOT WATER ANYWHERE
INSIDE THE MACHINE!



502 Highway 67
Kiel, WI 53042

Phone: 800-558-5807
Fax: 920-894-7029
www.frozencustard.com
www.stoelting.com

SAFETY

SAFETY WARNING:

Do Not attempt to assemble or take apart any parts of the machine without making sure the refrigeration and beater switches are in the “OFF” position and the keys are removed. Serious bodily injury may result.

IMPORTANT:

In order to eliminate the custard machine as a source of bacterial contamination, it is extremely important that the following instructions be followed exactly each time the machine is disassembled for cleaning as part of nightly shutdown procedures. Ross’s makes no warranties expressed or implied as to the introduction of bacteria or other pathogens into the custard mix run through the machine. It is beyond the scope of this manual to address proper mix handling procedures.

WARNING:

Never use HOT water anywhere inside the machine.

WARNING:

Refrigeration must be OFF when the water is present in the barrel or hopper.



ROSS & TELME WARRANTY

1. **Scope:**

Stoelting, LLC warrants to the first user (the "Buyer") that the freezing cylinders, hoppers, compressors, drive motors, speed reducers, beaters and agitator of Stoelting Ross and Telme product line will be free from defects in materials and workmanship under normal use and proper maintenance appearing within two (2) years, and that all other components of such equipment manufactured by Stoelting will be free from defects in material and workmanship under normal use and proper maintenance appearing within twelve (12) months after the date that such equipment is originally installed.

2. **Disclaimer of Other Warranties:**

THIS WARRANTY IS EXCLUSIVE; AND STOELTING HEREBY DISCLAIMS ANY IMPLIED WARRANTY OF MERCHANTABILITY OR FITNESS FOR PARTICULAR PURPOSE.

3. **Remedies:**

Stoelting's sole obligations, and Buyer's sole remedies, for any breach of this warranty shall be the repair or (at Stoelting's option) replacement of the affected component at Stoelting's plant in Kiel, Wisconsin, or (again, at Stoelting's option) refund of the purchase price of the affected equipment, and, during the first twelve (12) months of the warranty period, deinstallation/reinstallation of the affected component from/into the equipment. Those obligations/remedies are subject to the conditions that Buyer (a) signs and returns to Stoelting, upon installation, the Checklist/Warranty Registration Card for the affected equipment, (b) gives Stoelting prompt written notice of any claimed breach of warranty within the applicable warranty period, and (c) delivers the affected equipment to Stoelting or its designated service location, in its original packaging/crating, also within that period. Buyer shall bear the cost and risk of shipping to and from Stoelting's plant or designated service location.

4. **Exclusions and Limitations:**

This warranty does not extend to parts, sometimes called "wear parts", which are generally expected to deteriorate and to require replacement as equipment is used, including as examples but not intended to be limited to o-rings, auger seals, auger support bushings and drive belts. All such parts are sold

AS IS.

Further, Stoelting shall not be responsible to provide any remedy under this warranty with respect to any component that fails by reason of negligence, abnormal use, misuse or abuse, use with parts or equipment not manufactured or supplied by Stoelting, or damage in transit.

THE REMEDIES SET FORTH IN THIS WARRANTY SHALL BE THE SOLE LIABILITY STOELTING AND THE EXCLUSIVE REMEDY OF BUYER WITH RESPECT TO EQUIPMENT SUPPLIED BY STOELTING; AND IN NO EVENT SHALL STOELTING BE LIABLE FOR ANY INCIDENTAL OR CONSEQUENTIAL DAMAGES, WHETHER FOR BREACH OF WARRANTY OR OTHER CONTRACT BREACH, NEGLIGENCE OR OTHER TORT, OR ON ANY STRICT LIABILITY THEORY.

Installation Guide

Step 1 Running Line Sets:

* If the freezer is water-cooled, proceed to **Step 2 Running Electrical Connections**.

* Line sets are not supplied with the freezer.

* The line sets can be installed prior to receiving the custard freezer.

1) An air-cooled freezer requires a remote condensing unit and line set for each freezing cylinder. The line sets must be 3/8" for the liquid line and 7/8" for the suction line (The M202 suction line needs 5/8"). When running the line sets, each 10' of *vertical* rise, install a p-trap in the suction line. For every *horizontal* line set run, pitch the suction line towards the compressor to assist with oil returning back to the compressor.

2) After the line set is installed, perform a thorough leak test. Malfunctions of the equipment due to leaks in the line set are not covered by the Stoelting/Ross warranty.

3) Insulate the suction line with a minimum of 3/8" wall thickness or the wall thickness required by local code. In humid areas, use thicker insulation. In areas that are exposed to extreme temperatures, insulate the liquid line to prevent excessive sub cooling or heating of the liquid refrigerant. Fasten all lines securely along ceilings, walls and roofs. Avoid creating any type of kink in the lines. The Stoelting/Ross warranty does not cover malfunctions or capacity issues with equipment caused by kinks in the line sets.

4) Use good piping practices when installing line sets. Seal the ends of the line sets during installation to prevent exposure to the atmosphere and foreign objects. Blow the lines out with dry nitrogen to remove any debris that might be in the line sets. When running line sets through a wall or roof, mark the lines to eliminate confusion as to which line set is running to which cylinder.

Example: Mark the liquid and suction lines with the respective cylinder number. Facing the front of the freezer, cylinders are numbered left to right.

5) When brazing the joints, purge dry nitrogen through the lines to minimize oxidation of copper inside of the lines. The Stoelting/Ross warranty does not cover problems with the refrigeration system that are caused by oxidized material in the lines.

Step 2 Running Electrical Connections:

1) The freezer requires a separate electrical connection for each freezing cylinder. Refer to the nameplate on the freezer for proper electrical supply. Each freezing cylinder has its own electrical system and condenser so if one cylinder fails, the other cylinder will still be operational.

*An air-cooled freezer needs **two** circuits for each freezing cylinder, one for the remote condensing unit and one for the freezing cylinder.

*A water-cooled freezer needs one circuit for each freezing cylinder.

2) The electrical boxes are located behind the lower front panel. Labels indicate which cylinder each electrical box powers. No pigtailed are supplied with the freezer or condensing unit.

3) If the condensing unit is on the roof or ground, a quick disconnect box needs to be installed to provide power.

4) Do not turn on the power to the freezer or the condensing unit until the refrigeration lines have been connected and the system has been charged with refrigerant. Label the circuit breakers with information regarding which cylinder and condensing unit the breaker is designated for to prevent confusion if power ever needs to be shut off.

5) When connecting power to the freezer, run the line under the freezer and through the bottom of the electrical box. Remove the electrical box cover by loosening the four screws. The screws do not have to be removed. Connect the power to the 4-circuit terminal strip. The 4-circuit terminal strip is labeled L1, L2, L3, and GND. After connections are made, place the cover on the electrical box, but do not tighten the cover (for single-phase freezers the cover can be tightened). The electrical box may need to be accessed when checking for proper rotation of the motor.

Step 3 Plumbing Connections:

1) On water-cooled freezers, the water inlet is a standard garden hose connection and the water outlet is 5/8" OD copper tubing. The connections are located at the back of the freezer. Remove the rear panel to access the connections. Run the plumbing under the freezer frame. Water-cooled freezers use approximately 3 gallons of 75°F water per minute while in use (the M202 uses 2 gallons per minute). The freezer does not use any water when not in use.

2) The freezer is equipped with a dipping trough that requires a water inlet line and a drain line. The water inlet has a 5/16" OD brass female connector (the M202 female connector is 1/4" OD). Solder a 5/16" line to the water valve inlet using silver solder (the M202 requires a 1/4" line). Install a shutoff valve in the water inlet line. The drain connection is 1-1/2". Run a drain line from the trough to a drain on the floor. Leave enough slack in the drain line so that the lower front panel can be easily removed for service.

3) If the freezer is equipped with the hopper faucet option, run the hopper faucet tubing to the dipping trough inlet and install a T. This will supply water needed for the hopper faucet and the water valve for the dipping trough.

Step 4 Receiving and Installing Remote Condensing Units:

* The remote condensing units may be sent prior to delivery of the freezer.

* The freezer requires one remote condensing unit per cylinder.

1) Upon arrival, check the entire remote condenser units for any damage that may have occurred during transit. With the method of packaging used, the remote condensers should arrive in excellent condition. **The carrier is responsible for all damage in transit, whether visible or concealed.** Do not pay the freight bill until the remote condenser units have been checked for damage. Have the carrier note any visible damage on the freight bill. If concealed damage or a shortage is found later, advise the carrier within 10 days and request inspection. The customer must place a claim for damages and/or shortages in shipment with the carrier. Stoelting cannot make any claims against the carrier.

2) Remove cardboard covering off the condensing units.

3) Place the condensing units in their predetermined location, either on the roof or on the ground. A crane or forklift will be needed if the units will be placed on a roof. The condensing units weigh approximately 200 lbs. each.

4) Using ratchet with a 1/2" socket, remove the two lag bolts that secure the condensing unit to the pallet.

5) Place the condensing units on 4" x 4" treated wood or similar material so that the units are not sitting directly on the ground or the roof. Secure the condensing units to the 4" x 4" using lag bolts. Adhere to all local, state, and federal codes governing this type of installation. Some areas have specific "hurricane-proof" requirements for roof installations. Allow at least 2 feet of clearance on the air intake and discharge sides of the condensers. Do not set the condensers so that one is blowing air directly into the other condensing unit. The ideal set up is to have all the condensing units set in a row. See example diagram.

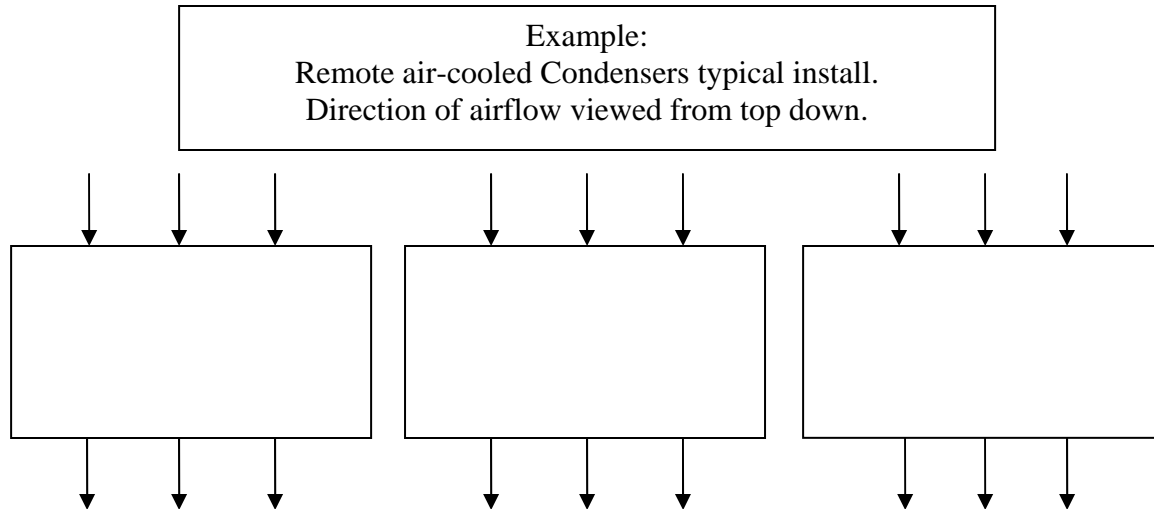

6) Use an Allen wrench to open the shut off valves and release some of the nitrogen charge in the condensing unit. The shut off valves are located on the outside of the condensing unit. If no nitrogen is present then the unit needs to be leak checked prior to connecting the refrigeration lines.

7) Braze the suction line and liquid line from the line sets to the condensing unit. When brazing, wrap the shut off valve with a cold wet rag and make sure that the valve is fully open. If valve is not wrapped, damage to the valve may result. When installing the suction line, angle it towards the condensing unit so that oil can flow back towards the compressor.

8) Use good piping practices. Keep pipes as clean as possible. Do not let any debris or copper shavings get inside system otherwise the refrigeration valves may not work properly.

Step 5 Receiving the Custard Freezer:

- 1) Upon arrival, check the entire freezer for any damage that may have occurred during transit. With the method of packaging used, the freezer should arrive in excellent condition. **The carrier is responsible for all damage in transit, whether visible or concealed.** Do not pay the freight bill until the freezer has been checked for damage. Have the carrier note any visible damage on the freight bill. If concealed damage or a shortage is found later, advise the carrier within 10 days and request inspection. The customer must place a claim for damages and/or shortages in shipment with the carrier. Stoelting cannot make any claims against the carrier.
- 2) Remove the top of the crate using a hammer or pry bar.
- 3) Remove the eight lag bolts from the freezer using a 1/2" ratchet. Remove the front and rear crate walls.
- 4) Remove the four lag bolts located inside the left and right crate walls using 1/2" ratchet. Remove the left and right crate walls.
- 5) Remove the plastic wrapping on the freezer. Remove the lower front and back panel on the freezer.
- 6) Remove the four lag bolts located inside freezer on the frame with a 9/16" ratchet. Remove the two lag bolts that hold the skid together with a 9/16" socket.
- 7) If the freezer has the shipping casters or if it is water-cooled, the casters will be in a box located in the hopper pan. A set of casters includes two casters with locks and two casters without locks. Screw the casters into the threaded holes and tighten them using a pair of channel locks. After installing the casters, knock out bottom 4" x 4" of the freezer skid.
 - * If the freezer does not come with casters, install the stainless steel legs. The legs are located in the hopper pan on top of the freezer. After installing the legs, use a pallet jack to move freezer into place.
- 8) Put front and back panels on the freezer.

Step 6 Setting In Place and Making Freezer Connections:

- 1) Roll the freezer into the desired location. Leave adequate space around the freezer for the removal of service panels. Remove the left, right, back and lower front service panels.
 - * After the refrigeration lines are connected, air-cooled freezers cannot be moved.
- 2) Use a pallet jack or floor jack to lift the front of the freezer, remove the two shipping casters with a pair of channel locks, and install the stainless steel legs. Make sure the legs are adjusted all the way in, and screw two of the legs into the frame. Secure them tightly using channel locks. Repeat with the back of the freezer.
 - * If the freezer is water-cooled, casters are standard with freezer.
- 3) Accurate leveling is necessary to ensure proper operation. Place a bubble level on top of the freezer at each corner to check for level condition. If adjustment is necessary, level the freezer by turning the bottom part of each leg or caster in or out.

To finish installing a water-cooled freezer, proceed to **Step 7 Running product and setting pressures for the custard freezer.**

5) Connect the refrigeration lines from the line sets to the freezer. Access the freezer from the left or right service panel. The refrigeration system has a charge of dry nitrogen. Use caution when connecting the lines. Connect the suction line first then connect the liquid line. Run the refrigeration lines under the freezer. There is approximately 6” of clearance between freezer and the floor. The stainless steel legs are adjustable and can raise the freezer up to 7” off the floor if necessary. Wrap the suction solenoid in a cold wet rag when soldering to prevent damage to the solenoid. Also, be aware of the electrical conduit inside custard freezer while soldering the refrigeration lines. A liquid line dryer is supplied with the freezer and should be the last connection made in the system. Use good piping techniques to keep the system clean. Do not leave the lines open and exposed for a long period.

5) After finishing the refrigeration connections, connect power to the freezer. Refer to **Step 2 Running Electrical Lines** for the proper procedures. Check the rotation of the beater shaft. When looking at the freezer from the front, the shaft needs to turn counterclockwise. If the shaft is turning the wrong direction, shut off power to the cylinder and switch the L1 and L3 wires. Check rotation again to verify the shaft is rotating counterclockwise. Once verified, tighten the screws on the electrical box cover.

*If the freezer is single phase and the beater shaft rotation is clockwise, then complete one of the following procedures. Check rotation after each procedure.

- A) Change programming on variable speed drive to reverse motor.
- B) Change the T1 and T3 output leads going to the motor from the drive.
- C) Change the leads inside the motor electrical box.

6) Check the refrigeration systems for leaks. When pressurizing the system, turn the refrigeration switch to hold position to energize the suction solenoid. Also, make sure that the shut off valves are open on the remote condensing unit. Check the refrigeration system with a minimum of 100 psi. Make sure the system will hold the pressure for a minimum of 2 hours.

7) After the leak check, connect a vacuum pump to the system and evacuate it to 500 microns for a minimum of 1 hour. Make sure the suction solenoid and the shut off valves on the condensing unit are opened. Perform a standing vacuum test. If the vacuum deteriorates and continues to rise there is a leak. Find it, repair it, and repeat the evacuation procedure until the freezer passes a standing vacuum test. While the refrigeration system is under a vacuum, insulate the suction line. Insulation is needed up to the shut off valve on the condensing unit. Use 3/8” tube insulation or insulation required by local code.

8) Use good refrigeration practices to charge the system with the required charge (see below). Make sure the suction solenoid is energized and that the shut off valves are open.

Model	Hopper Charge	Air-Cooled Charge per cylinder	Water-Cooled Charge per cylinder
CC101	16 oz of R-134a	24 lbs of R-404a	10 lbs of R-404a
CC202	18 oz of R-134a	24 lbs of R-404a	10 lbs of R-404a
CC303	19 oz of R-134a	24 lbs of R-404a	10 lbs of R-404a
CC404	20 oz of R-134a	24 lbs of R-404a	10 lbs of R-404a
M202	N/A	20 lbs of R-404a	8 lbs of R-404a

*Air-cooled freezers do not ship with refrigerant and require refrigerant to be supplied on site. Water-cooled freezers are factory charged. The hoppers for air-cooled and water-cooled freezers are factory charged.

*The charge for air-cooled freezers is sufficient for up to a 50 ft. line set. If the line set is longer, add 1 lb. of refrigerant for every 10 ft. of additional line (up to 150 ft. total).

Step 7 Running product and setting pressures for the custard freezer:

* Complete the **Custard Freezer Start-Up and Training Checklist** located with the spare parts kit or in the back of this manual and send it to Stoelting.

1) Remove all spare parts from the hopper before running product. Unwrap the parts and check for damage. Refer to the list in the manual to make sure no parts are missing. The cylinders need to be under a load to set the pressures. If custard is not available, RV antifreeze can be used as an alternative. Mix the RV antifreeze in a concentration of 1 part antifreeze to 1 part water. If RV antifreeze is used, the pressures will need to be rechecked when custard mix is available. The RV antifreeze will indicate that the system is functioning correctly.

2) Disassemble, clean and sanitize each freezing cylinder. Refer to the manual for proper instructions.

3) After assembling and sanitizing the freezer, add custard mix to the hopper. Follow the instructions in the manual to start freezing the custard (run one cylinder at a time to set the pressures). Connect gauges to the suction line and the discharge line. When product starts coming out of the faceplate, locate the low pressure gauge on the front of the freezer and set the AXV to 30 psi. Remove the white plastic cap from the AXV and turn the valve counterclockwise to decrease the pressure or clockwise to increase the pressure. Turn the valve 1/4 turn at a time and wait at least 1 minute before making another adjustment. Connect a gauge to the suction line at the compressor and make sure the pressure is 25 psi. Adjust the crankcase pressure regulator (CPR) if the pressure is not correct. Remove threaded brass cap on the front of the CPR and adjust the valve with a 5/16" Allen wrench. Connect a gauge to the suction line at the hopper and adjust the hopper AXV to 55 psi.

4) Check the faceplate to see if the custard is at the desired texture and temperature. The standard normal serving temperature of frozen custard coming out of the freezer is 18°-22°F.

5) Set the pressures for the remaining cylinders.

* If the freezer is water-cooled, the discharge pressure was already set at the factory. Run custard mix through the freezer to double-check and fine-tune the discharge pressure for the particular mix being used.

* The remote condenser unit has a head pressure control set for a minimum of 255 psi.

* Chocolate and vanilla mixes run differently. Usually the pressures in the chocolate cylinder will need to be set slightly lower than the pressures in the vanilla cylinder. Custard mixes that use an extract flavoring will also run differently. Try different pressure settings by adjusting the AXV. Adjust the pressure setting between 28-32 psi (the freezer will not operate correctly if the AXV is set lower than 28 psi).

6) If the freezer is equipped with the lemon ice option, set the lemon ice AXV. The lemon ice option is designated for one cylinder (right cylinder). With the system still running product, turn the lemon ice switch on. The AXV is located behind the cylinder in front of the freezer. Set the lemon ice AXV for 40 psi.

7) When testing is done, take the cylinders apart and clean the custard freezer. Refer to operations manual under shutdown and disassembly.

Trouble Shooting Guide for the Ross Frozen Custard Machine and Dipping Cabinet

Ross Custard Machine Problem and Possible Solutions

Custard is running to cold or Blades chatter during running:

- 1) First increase the flow; machine needs to run for at least a minute before you see a change in the product. Average flow setting while running custard is 1.5 to 2.
- 2) Hopper pan is low or out of mix.
- 3) Check to see if flow valve is plugged.
- 4) The refrigeration system for that barrel set to cold for the mix. Call Ross service department and we can help over the phone to adjust setting properly.
- 5) Check the belts on the motor to make sure they are not loose and slipping.
- 6) Blades may be worn. The blades need to be replaced annually.

Custard is running too soft:

- 1) First decrease the flow setting; machine needs to run for at least a minute before you see a change in the product. Decrease flow setting until you reach the desired texture. Average flow setting while running custard is 1.5 to 2.
- 2) Check to see if the flow valve is plugged.
- 3) No electrical power to the refrigeration condensing unit, need to check the main breaker for the condensing unit.
- 4) The refrigeration system for that barrel is set to warm for the mix. Contact Ross service department and a technician can help adjust system properly.
- 5) Condenser on remote unit is blocked and will need to be cleaned out.
- 6) For water-cooled models check to make sure that water was not shut off to the machine.
- 7) Refrigeration system not functioning correctly.

Beater freezes up in the hold cycle:

- 1) Custard was not cleared out of barrel when going from run mode to the hold cycle mode.
- 2) Motor needs to remain on when turning refrigeration switch from run to hold for at least 2 minutes before shutting the motor off otherwise the barrel will freeze up in the hold cycle.
- 3) Ranco temperature control (located on your service side on machine) is set to cold for the hold cycle; refer to the operating manual for proper settings.
- 4) Refrigeration system not functioning correctly.

Hold cycle not running:

- 1) Make sure the refrigeration switch is on the hold cycle mode.
- 2) Ranco temperature control (located on your service side on the machine) is set to warm. Need to refer to the operating manual for the proper setting.
- 3) Main circuit breaker for the refrigeration unit is tripped and needs to be reset.
- 4) Check that the electrical plug for that barrel is still plugged in to the outlet on the wall.

- 5) Condenser for remote unit is blocked and needs to be cleared.
- 6) For water-cooled machines check that the water supply was not turned off to the machine.
- 7) Refrigeration system not functioning correctly.

Beater motor freezes up in the run mode:

- 1) Hopper pan is out of mix.
- 2) Check that flow valve is not plugged.
- 3) Running the flow setting to low and need to increase the flow setting.
- 4) Check the belts to make sure they are not loose and slipping. Tighten if necessary.
- 5) Do not shut motor off while running custard. Barrel will freeze up instantly.
- 6) Refer to **Custard is running to cold** section in this trouble shooting guide.

Beater motor does not function:

- 1) Push the beater motor reset button located on your service side on the machine.
- 2) Check that machine is not unplugged from the outlet on the wall.
- 3) Main circuit breaker for that barrel is tripped and needs to be reset.

Custard stored in hopper is too cold:

- 1) Ranco temperature control (located on the service side on the machine) is set to cold. Refer to the operating manual for proper settings.
- 2) Refrigeration system is not functioning correctly.

Custard stored in hopper is too warm:

- 1) Make sure the hopper switch is on.
- 2) Ranco temperature control (located on the service side of the machine) is set to warm. Refer to the operating manual for proper settings.
- 3) If there is no display on the Ranco temperature control then need to check that hopper is plugged into the wall outlet. If plug is ok then need to check the main breaker for the outlet on the wall and reset if tripped.
- 4) Check condenser coil on the hopper-condensing unit (located inside machine under the beater motors) and clean with a soft brush or condenser coil cleaner if there is dust. After cleaning let run for 1 hour to see if temperature drops on thermostat.
- 4) Refrigeration system not functioning correctly.

Ross Dipping Cabinet Problem and Possible Solutions

Custard stored in cabinet too cold:

- 1) Ross Manufacturing recommends running enough custard to cover a 2-hour period. Custard stored in cabinet longer than 2 hours has a tendency to become to firm in the cabinet.
- 2) Refer to the operating manual for proper temperature settings. The Ranco temperature control will be located on some models in the front; on other models it will be located on the back of the cabinet. Allow at least 1 hour before you will see any change in the product and temperature.
- 3) Refrigeration system not functioning correctly.

Custard stored in cabinet too warm:

- 1) Refer to operating manual for proper temperature settings. After adjusting temperature allow cabinet to run for 1 hour before any change in product or temperature.
- 2) If light is not on when switch is on then need to check that dipping cabinet is still plugged into outlet. If it is need to check main breaker for that particular outlet and reset if tripped.
- 3) Check condenser coil (located inside cabinet, need to remove front or rear panel to access) for dust build up. If dust is present use a soft brush or condenser coil cleaner and remove dust build up. After cleaning condenser allow cabinet to run for 1 hour before you will see any change in the product or temperature change on the display.

Dipping Cabinet not cooling at all:

- 1) Check and see if light is on by the switch. If no light on check that unit is plugged into the wall and check that cord is not cut. Also need to check that the breaker for that outlet has not tripped. If the breaker has tripped then reset and check dipping cabinet if it is running.
- 2) Check condenser coil and make sure not plugged with dust, if it is need to clean and try running again.
- 3) Refrigeration system not functioning correctly and need to contact service technician at Ross Manufacturing for assistance.

***This is just a guideline to help you reduce the down time of the machine and for having to try and schedule a service technician to look at your machine. If you need any assistance with the machine after following this guideline call Ross manufacturing and speak with a service technician before calling a local refrigeration company. The Ross service technician will be able to help you further and whether or not you need to have a local technician look at the machine. Ross Manufacturing can be reached at our toll free # 1-888-339-4429, for after hour or weekends a service technician can be reached by calling the toll free number, the answering machine will direct you to a number of the service technician's on call.**

Typical Machine Settings

Note: Please use these settings as guidelines. Each machine may vary and should be set up for highest efficiency, best quality, and preferred product texture. Space has been provided for inputting the final settings after set up

Hopper Temperature Control

(Location within machine)

Note: Temperature settings may be adjusted for your particular requirements.

Ranco ETC 111000- One stage controller:

	<u>Factory Settings</u>	<u>Your Settings</u>
F/C:	F	_____
Temp:	38	_____
Diff:	1 degree	_____
Mode:	CL	_____

Hold Cycle Temperature Control

Note: Temperature setting may be adjusted for your particular settings.

Stage #1

	<u>Factory Settings</u>	<u>Your Settings</u>
F/C:	F	_____
Temp:	38	_____
Diff 1:	1 degree	_____
Mode:	CL	_____

Barrel Expansion Valve Adjustment

(Location within Machinery Section)

Note: Each machine and mix formulation have differing freezing points Therefore each machine must be adjusted for a particular mix. You may adjust each automatic expansion valve for your own particular setting and desired firmness.

Automatic Expansion Valve: *Original Factory Setting 32 PSIG*
Typical pressure setting for most custard mixes: 28-30 PSIG

Automatic Expansion Valve for Lemon Ice: *Original Factory Setting* 40 PSIG
Typical pressure settings for Lemon Ice: 40 PSIG

Your final valve setting for Custard_____

Your Final valve setting for Lemon Ice_____

Note: each machine will differ slightly in preferred setting.

Condensing Unit Settings: Air Cooled Units

(Location on each condensing unit)

Danfoss Head Pressure Control: Adjustable at 255 PSIG

High Pressure Safety Cut-Out: Non Adjustable at Approx. 350 PSIG

Low Pressure Safety Cut-Out: Cut-In 20 PSIG

Cut-Out 0 PSIG

Fan Cycling Controls: Non Adjustable at 180 PSIG

Crankcase Pressure Regulator 27 PSIG

PREVENTATIVE MAINTENANCE

Stoelting recommends following this preventative maintenance schedule to keep the freezer clean and operating properly.

WEEKLY

CLEAN INSIDE OF FREEZER

Remove all side panels and clean the inside of the freezer. Wipe any custard that may have dripped onto the inner panels with a damp soapy towel. Wash the drain tray.

CLEAN REAR SHAFT SUPPORT BUSHING

Remove the rear support bushing by unscrewing it. Remove the o-ring and examine it. Replace the o-ring if it is cracked or worn. Wash the bushing and lubricate the o-ring with Petrol-Gel.

CHECK FOR SHAFT ALIGNMENT

It is important to keep the auger shaft aligned at all times. There are a few early indications that the shaft is out of alignment. Make sure there are no metal shavings under the bearing. Inspect the rear coupling for wear. Check the front door plate for wear from the front bushing. If the shaft is out of alignment, the freezer may be making a lot of noise.

Contact Stoelting Customer Service for an alignment kit if you suspect that the auger shaft is out of alignment.

QUARTERLY

REPLACE BARREL PARTS

Follow the Parts Replacement Schedule to keep the freezer operating properly.

CLEAN CONDENSER COILS (AND FILTERS IF APPLICABLE)

The coils on the hopper, dipping cabinet and remote condenser need to be cleaned to ensure proper airflow. Use compressed air to clean the condensers. Blow the air in the opposite direction of the normal airflow. If the condenser has a filter, remove it and vacuum or brush clean. Rinse the filter with clean water and allow it to dry before replacing it on the condenser.

ANNUALLY

REPLACE BARREL PARTS ACCORDING TO REPLACEMENT SCHEDULE

Follow the Parts Replacement Schedule to keep the freezer operating properly.

DRIVE BELT WEAR AND TENSION

Inspect the drive belts for wear. Check for wear marks from the belts rubbing on the pulley.

Press firmly on the belts. When tension is properly adjusted, the belt will depress the approximate width of the belt with the pressure of a finger. If an adjustment is necessary, loosen the bolts holding the motor to the frame and push the motor downward. Use a 5' long 2x4 as a lever to get the proper tension, and then tighten the bolts.

LUBRICATE BEARINGS AND MOTORS

The pillow block bearings and the motors have grease fittings. Use a grease gun with Shell Alvania RL2, Texaco Multifak 2, or equivalent as lubrication. Add enough grease on the bearings so that a small amount appears on the drive shaft. The motor requires a small amount of grease. Apply one compression of the grease gun to the grease fitting on the motor. Wipe all fittings clean after lubricating.

M202 PARTS REPLACEMENT SCHEDULE

Part Description & Part Number	3 Months	Annually	Qty.
Front Wear Bushing #C-2000-40	X		2
Large O-Ring #624782	X		2
Double Lip Shaft Seal #SL-0010	X		2
KO Dirt Blaster Condenser Cleaner BL-0030	X		1
Blades C-2000-51		X	16

***To order the replacement parts please contact Stoelting Customer Service at 800-558-5807**

Revised 7-30-07

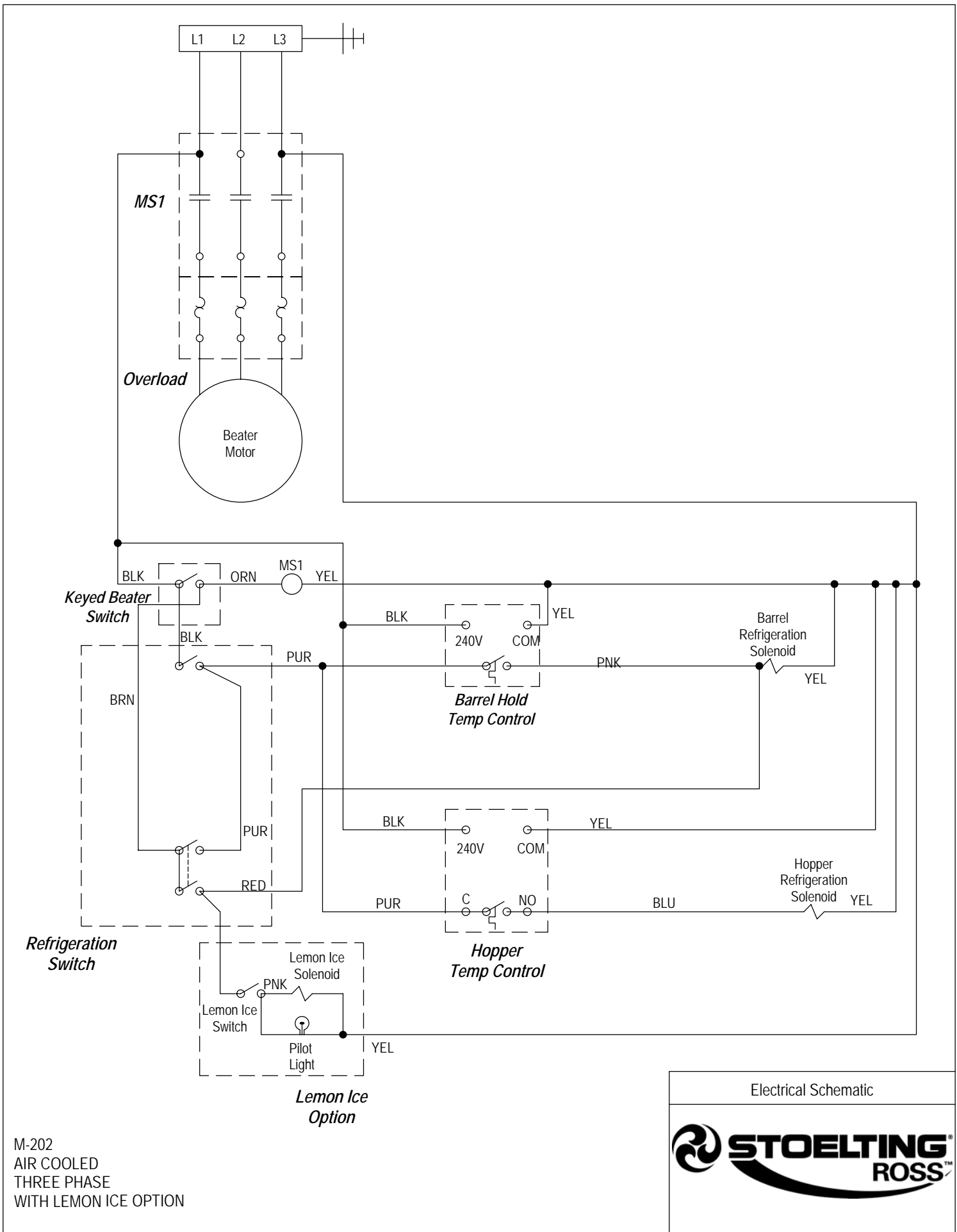

M-202
 AIR COOLED
 THREE PHASE
 WITH LEMON ICE OPTION

Electrical Schematic



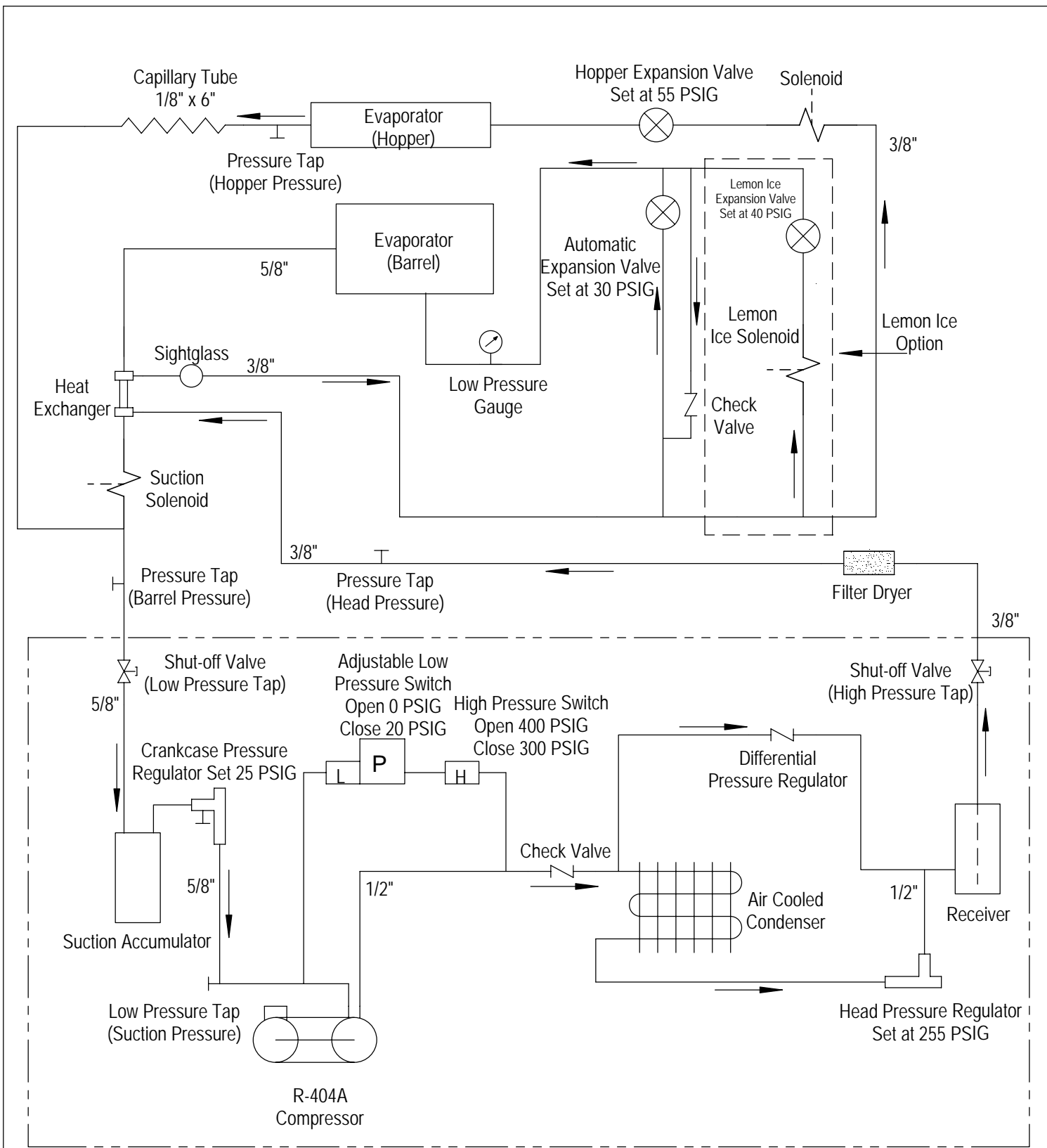

*Remote Air Cooled
Condensing Unit*

Refrigeration Schematic

**STOELTING
ROSS**

M-202
AIR COOLED

Custard Freezer Start-Up and Training Checklist



FOODSERVICE EQUIPMENT
502 Hwy 67
Kiel WI 53042

Distributor Instructions: Complete this form, obtain customer comments and signature and send to:

IMPORTANT: THIS SHEET MUST BE COMPLETED AND MAILED, FAXED, OR EMAILED WITHIN 30 DAYS OF START-UP BY THE DISTRIBUTOR OR END-USER TO STOELTING IN ORDER TO REGISTER THE UNIT UNDER WARRANTY. IF WE DO NOT RECEIVE IT, WE CANNOT PROCESS FUTURE WARRANTY CLAIMS.

NOTE: A separate form must be submitted for each individual freezer.

A	BUYER INFORMATION	FREEZER INFORMATION (See freezer I.D. plate)	
	Installed at (business name): _____	Model No. _____	Serial No. _____
	Contact person: _____	Check one:	Check one:
	Address: _____	<input type="checkbox"/> 115 volts	<input type="checkbox"/> single phase
City: _____	<input type="checkbox"/> 208 volts	<input type="checkbox"/> three phase	
State: _____ Zip: _____ Phone: () _____	<input type="checkbox"/> 230 volts	<input type="checkbox"/> air-cooled	
DISTRIBUTOR INFORMATION	APPOINTMENT SCHEDULES		
Business Name: _____	Check-out/start-up scheduled for: ___/___/___ at ___AM/PM		
Account Number: _____	Appointments arranged by: _____		
AUTHORIZED SERVICE COMPANY (IF DIFF. THAN DISTR.)	with (buyer contact): _____		
Business Name: _____	NOTE: Before leaving for appointment, phone to see that:		
Address: _____	<input type="checkbox"/> electrical complete		
City: _____	<input type="checkbox"/> water & drain complete (water-cooled)		
State: _____ Zip: _____ Phone: () _____	<input type="checkbox"/> mix, cones, cups, syrup, etc. available		
	<input type="checkbox"/> trainee personnel available		

B	CHECK-OUT START-UP CHECKLIST (Each column represents a freezing cylinder)					
	<p>1 2 3 4 (Check a column for each freezing cylinder)</p> <p><input type="checkbox"/> <input type="checkbox"/> <input type="checkbox"/> <input type="checkbox"/> Proper voltage, phase, breaker (check against nameplate)</p> <p><input type="checkbox"/> <input type="checkbox"/> <input type="checkbox"/> <input type="checkbox"/> Proper wire size per local code</p> <p><input type="checkbox"/> <input type="checkbox"/> <input type="checkbox"/> <input type="checkbox"/> High or unstable leg to L-2 (3-phase only)</p> <p><input type="checkbox"/> <input type="checkbox"/> <input type="checkbox"/> <input type="checkbox"/> Freezer level, front-to-back and side-to-side</p> <p><input type="checkbox"/> <input type="checkbox"/> <input type="checkbox"/> <input type="checkbox"/> Parts and accessories kit complete</p> <p><input type="checkbox"/> <input type="checkbox"/> <input type="checkbox"/> <input type="checkbox"/> Nuts, bolts, screws, electrical tight</p> <p><input type="checkbox"/> <input type="checkbox"/> <input type="checkbox"/> <input type="checkbox"/> Drive belt tension/no lubricant leaks/check pulley and set screws</p> <p><input type="checkbox"/> <input type="checkbox"/> <input type="checkbox"/> <input type="checkbox"/> Auger rotating counterclockwise</p> <p><input type="checkbox"/> <input type="checkbox"/> <input type="checkbox"/> <input type="checkbox"/> Checked pressures on high side, suction side and barrel.</p> <p><input type="checkbox"/> <input type="checkbox"/> <input type="checkbox"/> <input type="checkbox"/> Refrigeration level during operation (clear sight glass)</p> <p><input type="checkbox"/> <input type="checkbox"/> <input type="checkbox"/> <input type="checkbox"/> Checked alignment</p>	Actual Settings	1	2	3	4
		Supply Voltage	_____	_____	_____	_____
		Head Pressure	_____	_____	_____	_____
		Suction Pressure	_____	_____	_____	_____
		Barrel Pressure	_____	_____	_____	_____
			1 2 3 4			
		<input type="checkbox"/> <input type="checkbox"/> <input type="checkbox"/> <input type="checkbox"/>	<input type="checkbox"/> Checked low pressure switch settings.			
		<input type="checkbox"/> <input type="checkbox"/> <input type="checkbox"/> <input type="checkbox"/>	<input type="checkbox"/> Locked thermostat settings.			
		<input type="checkbox"/> <input type="checkbox"/> <input type="checkbox"/> <input type="checkbox"/>	<input type="checkbox"/> Water lines flushed before connection (W/C)			
		<input type="checkbox"/> <input type="checkbox"/> <input type="checkbox"/> <input type="checkbox"/>	<input type="checkbox"/> Proper water and drain size (W/C)			
		<input type="checkbox"/> <input type="checkbox"/> <input type="checkbox"/> <input type="checkbox"/>	<input type="checkbox"/> Proper clearance for air circulation (A/C Remote)			

B	TRAINING CHECKLIST	
	<p>Check off as completed:</p> <p><input type="checkbox"/> Reviewed Owner's Manual with trainees.</p> <p><input type="checkbox"/> Reviewed Operator's Safety Precautions in Owner's Manual</p> <p><input type="checkbox"/> Reviewed Warranty Shown in Owner's Manual</p> <p><input type="checkbox"/> Disassemble, wash all parts, sanitize, lubricate & assemble.</p> <p><input type="checkbox"/> Sanitize and start-up.</p> <p>Note: Sanitizing must be done immediately before starting freezer.</p> <p><input type="checkbox"/> Check product temperature _____ °F, overrun _____</p> <p><input type="checkbox"/> Shutdown and cleaning procedure.</p>	<p><input type="checkbox"/> Check for auger seal, bearing & flight wear each time the freezer is cleaned.</p> <p><input type="checkbox"/> Point out where Service Information Decal/Label is placed by the Distributor or Service Contractor.</p> <p><input type="checkbox"/> Key points: minimum mix level in hopper, etc.</p> <p><input type="checkbox"/> Explain how foam in the hopper can prevent the low mix light from illuminating.</p> <p><input type="checkbox"/> Discuss returning included survey if they choose.</p>

B	<p>Training conducted by:</p> <p>Name: _____ Date: ___/___/___</p> <p>Check one: <input type="checkbox"/> Distributor <input type="checkbox"/> Authorized Service Agency</p>	<p>LIST OF TRAINEES - Name of Trainees -</p> <p>_____</p> <p>_____</p> <p>_____</p>
	<p>Inspection/Checkout done by:</p> <p>Name: _____ Date: ___/___/___</p> <p>Check one: <input type="checkbox"/> Distributor <input type="checkbox"/> Authorized Service Agency</p>	<p>SIGNATURE REQUIRED</p> <p>Inspection, check-out and operator training has been performed on the above freezer. I have read and understand the warranty shown in the Owner's Manual.</p> <p>x _____</p> <p>Signature, Buyer/Manager/Supervisor Date</p>