



- TASTE THE DIFFERENCE -

MODEL SLX400E

These slim line soft serve machines produce the best tasting highest quality frozen dessert. Offer your guests smooth creamy consistent yogurt, ice cream, custard or sorbet! The 22" wide footprint allows for more units in a smaller space. The perfect yogurt shop freezer is great for adding flavors to ice cream shops, too! Great for QSRs, retirement villages and hospital cafeterias.

The Electro Freeze Advantage

- **Innovative Solutions** providing the Best product quality in the industry.
- **Meets ADA Specifications** for self service applications
- **Precision dual Smart control** monitors Temperature and Consistency to provide superior taste and quality.
- **Multi-function LED display** with manager smart tools.
- **Superior low temp refrigeration** system provides Best in class production and product quality
- **Compact design** with a small foot print.
- **Twist feature** will dispense two separate flavors or equal combinations of both.
- **Self-closing handles** eliminate waste
- **Patented auger** gently blends reducing agitation and maintaining product quality and consistency.
- **Durable polymer**, long wearing nonreversible blades offer lower maintenance costs and better product quality
- **Simple to operate** and easy to clean
- **Experience Tells** Electro Freeze has been manufacturing quality frozen treat machines since 1929. Superior engineering, product innovations, sturdy construction, quality craftsmanship and dependable performance are Electro Freeze hallmarks.

SOFT SERVE FREEZER GENESIS SERIES™ featuring

**Virtual Quality
Management System™**



**Let VQM help manage your frozen
dessert business more effectively.**

SLX400E Soft Serve Freezer

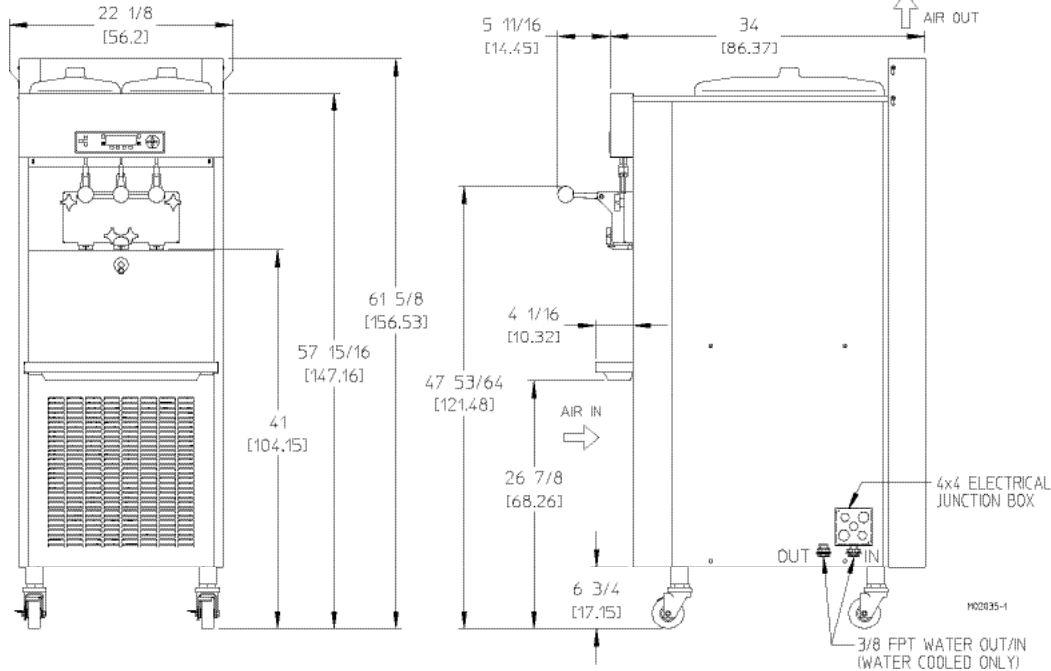

MODEL SLX400E SPECIFICATIONS

Due to continual product improvements all specifications are subject to change without notice.

Weights	lbs.	kgs.
Net	470	213
Crated	568	257
	cu.ft.	cu.m.
Volume	58.42	1.65
Dimensions	in.	cm
Width	22-1/8	56.20
Depth	30-1/8	76.52
Height	60-11/16	154.15

Electrical	Total Amps	Maximum Fuse Size	NEMA Plug Type
208-230/60/1 Air	16	20	6-20P
208-230/60/1 Water	16	20	6-20P
	Total Amps	kW	Poles (P) Wires (W)
220-240/50/1 Air	15.0	3.1	2P 3W
220-240/50/1 Water	15.7	3.2	2P 3W

Electrical characteristics other than above available on request from factory or local distributor. Check nameplate for exact electrical data.

Bidding Spec

Electrical: Volt _____ Hz _____ Ph _____
 Cooling: _____ Neutral _____ Yes _____ No
 Options: _____

Electrical

One dedicated electrical connection is required. 60 Hertz units connects to a standard NEMA 6-20R receptacle. See electrical chart for the proper requirement. Consult your local electrical codes for cord and receptacle specifications.

Beater Motor

Two, 1 hp.

Refrigeration Systems

One, 6,900 Btuh. R404a.
 Separate Hopper Refrigeration, One, 500 Btuh, R134a.
 Btuh may vary depending on compressor used.

Air Cooled

6" (15.2 cm) air space required on rear panel for proper air circulation and be open on the top.

Mix Hopper Capacity: two - 12 quarts (11.4 liters) each
Freezing Cylinder Capacity: two - 2.7 quarts (2.6 liters) each

Certified and/or listed by:



*UL listed and listed by Underwriters Laboratories under Canadian National Standard C22.2 No. 120-13

**Selected voltages only. Contact H.C. Duke to verify agency needs.

Authorized Distributor