



MB

Dual Temperature Mini Bunker Cooler and Freezer

500 S. Falkenburg Road
Suite 200 | Tampa, FL 33619
800.441.4014 | 813.870.0340
www.excellenceindustries.com

The company reserves the right to change the design and/or specifications of these products without notice. Printed in the USA.
Current version 02.21

KEY ASPECTS

SPECIAL FEATURES:

- Painted steel interior
- Cold wall evaporator
- Baskets include 2 dividers each
- Casters standard, front locking
- Environmentally friendly hydrocarbon refrigerant

OPTIONS:

- LED light bar
- Lock & key
- Graphics

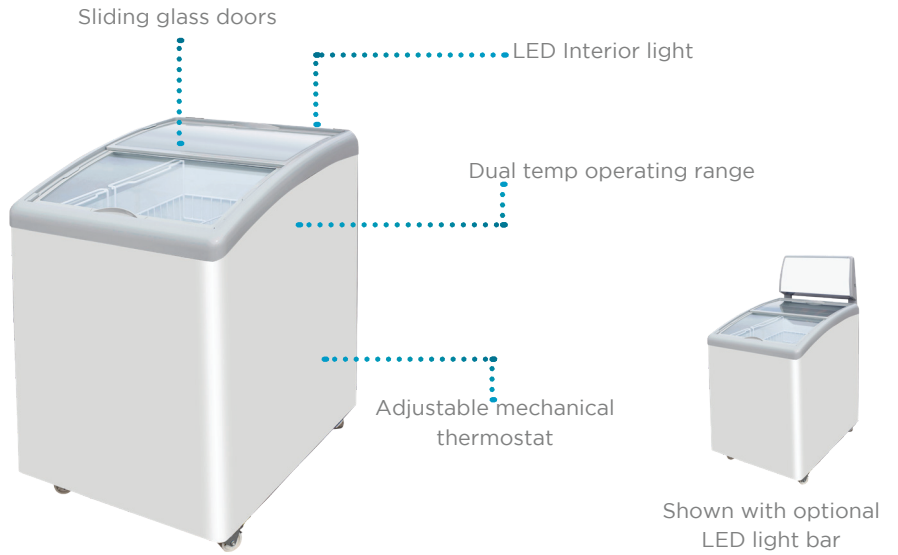

Complies with 2017 DOE standards for commercial cooler and freezer

TECHNICAL SUMMARY

| MODEL | SIZE | | | | ELECTRICAL | REFRIGERATION | | | OTHER | | |
|---------|--|------------|-------------------|--------------------------|------------------|---------------|---------------|-------------|---------------|-------------------|--------------------|
| | Dimensions (inches)* Width x Depth x Height | Cubic Feet | Net Weight (lbs.) | Shipping Weight (lbs.)** | Voltage/Hz/Phase | Running Amps | Compressor HP | Refrigerant | Temperature | Number of baskets | Container Quantity |
| MB-2HCD | 23 x 27 3/8 x 33 1/2 | 4.8 | 97 | 105 | 115/60/1 | 1.0 | 1/9 | R-600a | -5°F to +40°F | 2 | 168 |

*Dimensions are all nominal lengths

**Does not include weight of pallet when needed

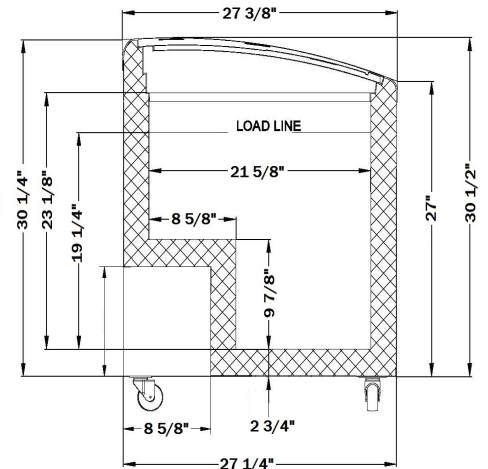
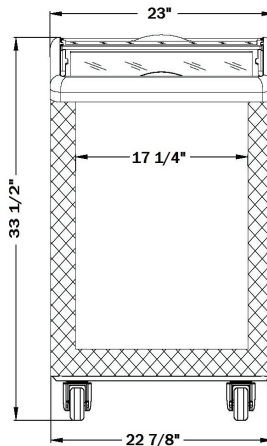

Optional light bar adds 11 3/8"



500 S. Falkenburg Road
Suite 200 | Tampa, FL 33619
800.441.4014 | 813.870.0340
www.excellenceindustries.com
ver. 02.21