



**LB 502**

**9024**

Codice Macchina  
Machine Code  
Code Machine  
Machinencode  
Código de Máquina

LISTA DEI RICAMBI  
LIST OF SPARE PARTS  
LISTE DES PIECES DE RECHANGE  
ERSATZTEIL-LISTE  
LISTA DE REPUESTOS





Via Emilia, 45  
40011 Anzola dell'Emilia (BO)  
Italy

☎ +39 051 6505111

📠 +39 051 732178

🌐 <http://www.carpigiani.com>

#### **CARPIGIANI**

Tutti i diritti riservati

Nessuna parte di questo manuale può essere riprodotta, memorizzata in un sistema di archiviazione o trasmessa a terzi in qualsiasi forma o con qualsiasi mezzo, senza una preventiva autorizzazione scritta di CARPIGIANI.

CARPIGIANI si riserva il diritto di apportare in qualsiasi momento e senza preavviso, modifiche e miglioramenti ai suoi prodotti allo scopo di elevarne costantemente la qualità, pertanto anche questa pubblicazione può essere soggetta a modifiche.

#### **CARPIGIANI**

All rights reserved

Neither the whole of this document nor any individual portion thereof may be reproduced, stored on an electronic filing system or transmitted to third parties in any form thereof any means, without the prior written consent of CARPIGIANI.

The technical data contained in this document is indicative and not binding, insofar as CARPIGIANI reserves the right to make modifications and improvements to its products at any time in order to enhance the quality thereof.

#### **CARPIGIANI**

Tous droits réservés

Il est interdit de procéder à la reproduction intégrale ou partielle de ce document, à sa mise en mémoire dans un système d'archives ou à sa transmission à des tiers sous quelque forme que ce soit sans l'auto-

risation écrite préalable de CARPIGIANI.

Les données techniques contenues dans ce document sont fournies à titre indicatif et non contraignant, dans la mesure où CARPIGIANI se réserve le droit d'apporter à tout moment des modifications et des améliorations à ses produits pour en élever constamment la qualité.

#### **CARPIGIANI**

Alle Rechte vorbehalten

Das vorliegende Handbuch bzw. Teile davon dürfen nicht ohne vorherige schriftliche Genehmigung der Fa. CARPIGIANI nachgedruckt, in Speichersystemen abgelegt oder in beliebiger Form und mit beliebigen Mitteln an Dritte weitergegeben werden.

Die Fa. CARPIGIANI behält sich das Recht vor, in Sinne der laufenden Steigerung der Qualität jederzeit und ohne Ankündigung Änderungen und Verbesserungen an ihren Produkten vorzunehmen. Daher kann auch die vorliegende Veröffentlichung Änderungen unterliegen.

#### **CARPIGIANI**

Todos los derechos reservados

Ninguna parte de esta publicación puede ser reproducida, almacenada o transmitida de ninguna forma, no por ningún medio, sin la previa autorización escrita por parte de CARPIGIANI.

Los datos técnicos contenidos en este documento son indicativos y no constituyen compromiso, ya que CARPIGIANI se reserva el derecho de realizar en cualquier momento modificaciones y mejoras en sus productos con el objeto de incrementar constantemente su calidad.

# INDICE GENERALE GENERAL INDEX INDEX GÉNÉRAL ALLGEMEINES VERZEICHNIS ÍNDICE GENERAL

## ITALIANO

INTRODUZIONE.....	5
COME CONSULTARE IL MANUALE .....	7
INDICE DEI GRUPPI FUNZIONALI.....	10
TAVOLE RICAMBI.....	12

## ENGLISH

INTRODUCTION.....	5
HOW TO USE THIS MANUAL .....	7
INDEX OF MACHINE GROUPS AND ASSEMBLIES .....	10
SPARE PARTS ILLUSTRATIONS.....	12

## FRANÇAIS

INTRODUCTION.....	6
COMMENT UTILISER CE MANUEL.....	7
INDEX DES GROUPES FONCTIONNELS DE LA MACHINE .....	10
TABLEAU DES PIÈCES DE RECHANGE.....	12

## DEUTSCH

EINLEITUNG.....	6
NACHSCHLAGEN DES HANDBUCHS .....	7
VERZEICHNIS DER FUNKTIONSBAUGRUPPEN .....	10
ERSATZTEILTAFELN .....	12

## ESPAÑOL

INTRODUCCIÓN .....	6
CÓMO CONSULTAR EL MANUAL .....	7
ÍNDICE DE LOS GRUPOS FUNCIONALES DE LA MAQUINA.....	10
TABLAS Y RECAMBIOS.....	12

# INTRODUZIONE INTRODUCTION INTRODUCTION EINLEITUNG INTRODUCCIÓN

## ITALIANO

### Come consultare il MANUALE PARTI DI RICAMBIO:

Il Manuale Parti di Ricambio è costituito da Tavole grafiche e da Tabelle.

#### Tavole grafiche:

- Le tavole riportano il disegno esploso dei gruppi principali della macchina.
- La suddivisione delle tavole è identificata nella "TAV. 00".
- Ogni particolare di ricambio è identificato da un numero di posizione, i numeri di posizione posti in un riquadro identificano i particolari di ricambio consigliati.

#### Tabelle:

- Le tabelle riportano i Numeri di Posizione, la Descrizione, il Codice del particolare e la versione della macchina.
- Nel caso in cui lo stesso numero di posizione sia riportato più volte, ma associato a codici differenti, è necessario, all'atto dell'ordine, specificare la matricola della macchina in possesso del cliente, al fine di identificare il codice del particolare da fornire.

Per ordinare uno o più particolari di ricambio identificare sulla "TAV. 00" la tavola in cui è rappresentato il gruppo macchina in cui è presente il particolare, identificare quindi sulla tavola il particolare ed il relativo numero di posizione, quindi ricercare sulle tabelle il numero di posizione ed il corrispondente codice.

## ENGLISH

### How to consult the SPARE PARTS MANUAL:

The Spare Parts Manual is made up of Drawing Plates and Tables.

#### Drawing Plates:

- The plates contain the exploded views of the main units comprising the machine.
- The subdivision of the plates is listed on "TAV. 00".
- Each spare parts item is identified by a position number, position numbers found in a box indicate the spare parts items recommended.

#### Tables:

- The tables list the Position numbers, Descriptions, the Codes for items and the machine version.
- When the same position number appears more than once, but is also associated with different codes, specify the serial number of the customer's machine when ordering for the purpose of identifying the code for the item to be supplied.

To order one or more spare part items, identify the plate on "TAV. 00" representing the machine unit on which the item is located. Locate the item on the plate and the corresponding position number as well. Then use the position number to locate the corresponding code on the table.

## FRANÇAIS

### Comment consulter le LIVRET DES PIÈCES DÉTACHÉES:

Le livret des Pièces Détachées se compose de Planches et de Tableaux.

#### Planches:

- Les planches illustrent la vue éclatée des groupes principaux de la machine.
- La "TAV. 00" illustre la subdivision des différentes planches.
- Chaque pièce détachée est identifiée par un numéro de repère; les numéros de repère en encadré identifient les pièces détachées conseillées.

#### Tableaux:

- Les tableaux indiquent les Numéros de repère, la Désignation des pièces, les Codes des pièces en question et la version de la machine.
- Si la même numéro de repère indiqué plusieurs fois mais qu'il est associé à des codes différents, lors de la commande il faut préciser le numéro de série de la machine; cela permettra d'identifier le code de la pièce à fournir.

Pour commander une ou plusieurs pièces détachées, repérer sur la "TAV. 00" la planche représentant le groupe dont fait partie la pièce, ensuite identifier la pièce en question sur la planche ainsi que son numéro de repère, puis rechercher sur les tableaux le numéro de repère et le code y relatif.

## DEUTSCH

### Hinweise für die Konsultation des ERSATZTEILHANDBUCHES:

Das Ersatzteillandbuch besteht aus graphischen Abbildungen und Tabellen.

#### Graphische Abbildungen:

- Die Abbildungen umfassen die Detailzeichnung der Hauptaggregate der Maschine
- Die Aufgliederung der Abbildungen ist in „TAV. 00“ angegeben.
- Jedes Ersatzteildetail ist mit einer Positionsnummer identifiziert; die eingerahmten Positionsnummern identifizieren die empfohlenen Ersatzteildetails.

#### Tabellen:

- In den Tabellen sind die Positionsnummern, die Beschreibung, der Code des Teils aufgelistet und die Maschine Version.
- Ist dieselbe Positionsnummer mehrmals in Zusammenhang mit anderen Code angegeben, muß bei der Bestellung die Maschinenummer angegeben werden, um den Code des zu liefernden Ersatzteils ausfindig machen zu können.

Um eines oder mehrere Ersatzteile zu bestellen, anhand der „TAV. 00“ die Abb. feststellen, in der das Maschinenaggregat dargestellt ist, für das das Teil bestimmt ist; anhand dieser Abb. dann das Ersatzteil und die entspr. Positionsnummer identifizieren und schließlich in den Tabellen die Positionsnummer und den entspr. Code suchen.

## ESPAÑOL

### COMO CONSULTAR EL MANUAL DE PIEZAS DE REPUESTO:

Manual Piezas de Repuesto está formado por Tablas gráficas y por Cuadros

#### Tablas gráficas:

- Las tablas indican el dibujo expuesto individualmente en todos sus particulares (tridimensional) de los grupos principales de la máquina.
- La subdivisión de las tablas está identificada en la "TAV. 00".
- Cada pieza de repuesto se identifica por un número de posición, los números de posición colocados en un recuadro identifican las piezas de repuesto aconsejadas.

#### Cuadros:

- Los Cuadros indican los Números de Posición, la Descripción, el Código de la pieza y la versión de la máquina.
- En el caso de que el mismo número de posición esté indicado más de una vez, pero asociado a códigos diferentes, es necesario, en el momento del pedido, especificar la matrícula de la máquina que posee el cliente, con el fin de identificar el código de la pieza que hay que suministrar.

Al hacer el pedido de una o más piezas de repuesto, identificar en la "TAV. 00" la tabla en la que está representado el grupo máquina en donde se halla la pieza, por consiguiente identificar en la tabla la pieza y el relativo número de posición, después buscar en los cuadros el número de posición y el correspondiente código.

## COME CONSULTARE IL MANUALE HOW TO USE THIS MANUAL COMMENT UTILISER CE MANUEL NACHSCHLAGEN DES HANDBUCHS CÓMO CONSULTAR EL MANUAL

### ITALIANO

- Nella figura di pagina 10 individuare il gruppo funzionale dove può essere la parte desiderata e di conseguenza individuare la tavola inerenti al gruppo scelto.
- Nelle pagine seguenti procedere alla ricerca della tavola seguendo la progressione numerica.
- Cercare infine la parte desiderata e memorizzarne codice e descrizione.

### ENGLISH

- In the figure shown on page 10, identify the functional group which is likely to contain the part you are looking for.
- Once the title has been found, keep in mind the part number and search the illustration following the numerical sequence.
- Locate the desired spare part and keep in mind its part number and description.

### FRANÇAIS

- Dans la figure illustrée en page 10, repérer le groupe fonctionnel qui pourrait contenir la pièce recherchée.
- Une fois le titre repéré, mémoriser le numéro de code et procéder à la recherche de l'illustration en suivant la progression des codes.
- Chercher la pièce souhaitée et en mémoriser le code et la désignation.

### DEUTSCH

- In der Abbildung auf Seite 10 die Funktionsbaugruppe, in der sich das gewünschte Teil befinden kann, und somit die Tafel der entsprechenden Baugruppe feststellen
- Auf den Folgeseiten die Tafel anhand der laufenden Nummerierung ausfindig machen
- Schließlich das gewünschte Teil suchen und die zugehörige Teilenummer und Beschreibung notieren.

### ESPAÑOL

- En la figura en la página 10 halle el grupo funcional donde puede encontrarse la pieza deseada.
- Una vez hallado el título, tome nota del número de código y proceda con la búsqueda de la tabla según la progresión numérica.
- Al final, halle la pieza deseada y memorice su código y descripción.





**INDICE DEI GRUPPI FUNZIONALI DELLA MACCHINA  
INDEX OF MACHINE GROUPS AND ASSEMBLIES  
INDEX DES GROUPES FONCTIONNELS DE LA MACHINE  
VERZEICHNIS DER FUNKTIONSBAUGRUPPEN DER MASCHINE  
ÍNDICE DE LOS GRUPOS FUNCIONALES DE LA MAQUINA**



**CARPIGIANI**

---

GRUPPI FUNZIONALI  
FUNCTIONAL GROUPS  
GROUPES FONCTIONNELS  
FUNKTIONSBAUGRUPPEN  
GRUPOS FUNCIONALES

NUMERO TAVOLA  
TABLE NUMBER  
NUMÉRO DE TABLE  
TAFEL NR.  
NÚMERO DE TABLA

**00**

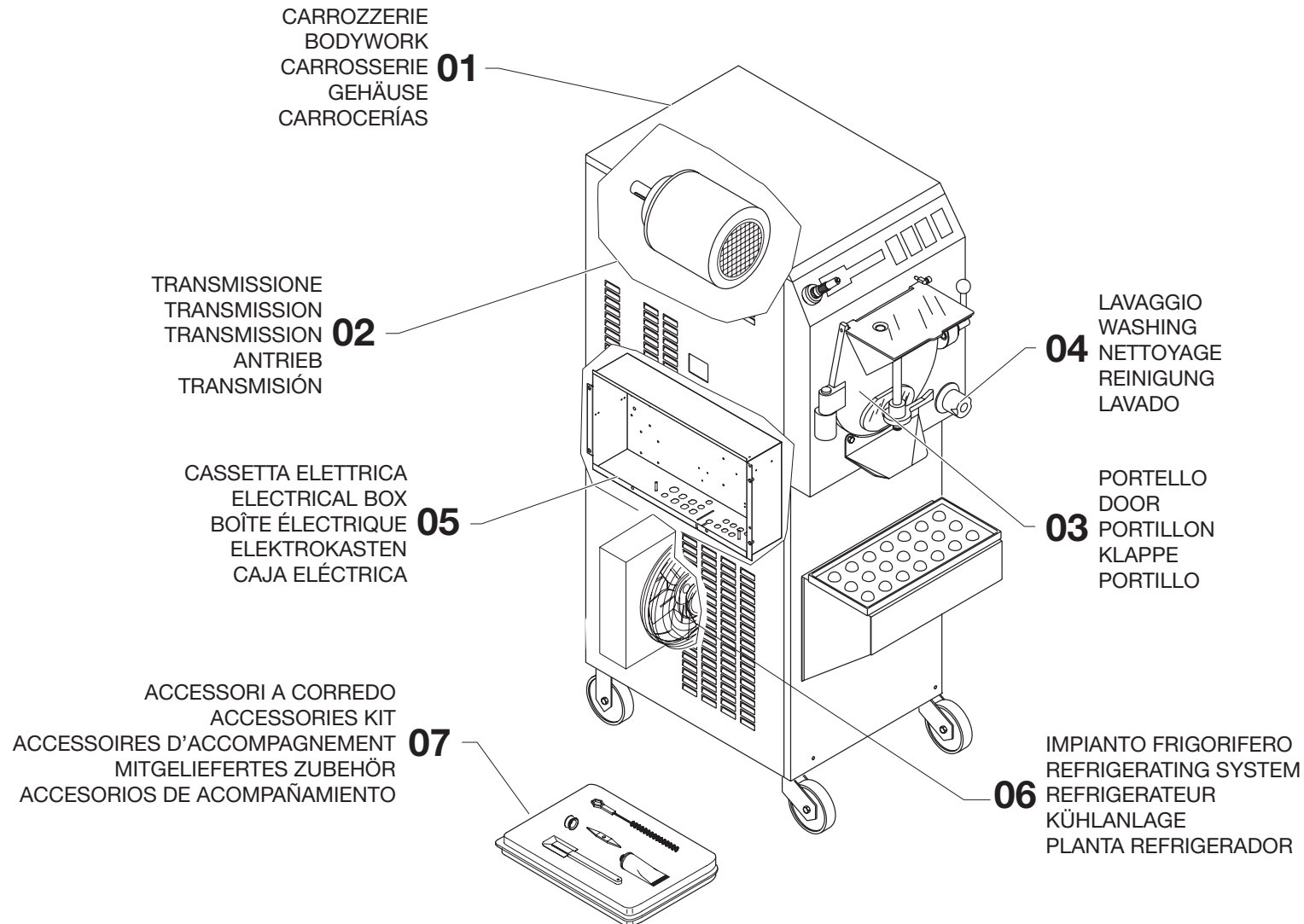

**TAVOLE RICAMBI  
SPARE PARTS TABLES  
TABLEAU DES PIÈCES DE RECHANGE  
ERSATZTEIL-ÜBERSICHTEN  
TABLAS Y RECAMBIOS**



**CARPIGIANI**

---

CARROZZERIE  
BODYWORK  
CARROSSERIE  
GEHÄUSE  
CARROCERÍAS

NUMERO TAVOLA  
TABLE NUMBER  
NUMÉRO DE TABLE  
TAFEL NR.  
NÚMERO DE TABLA

**01**

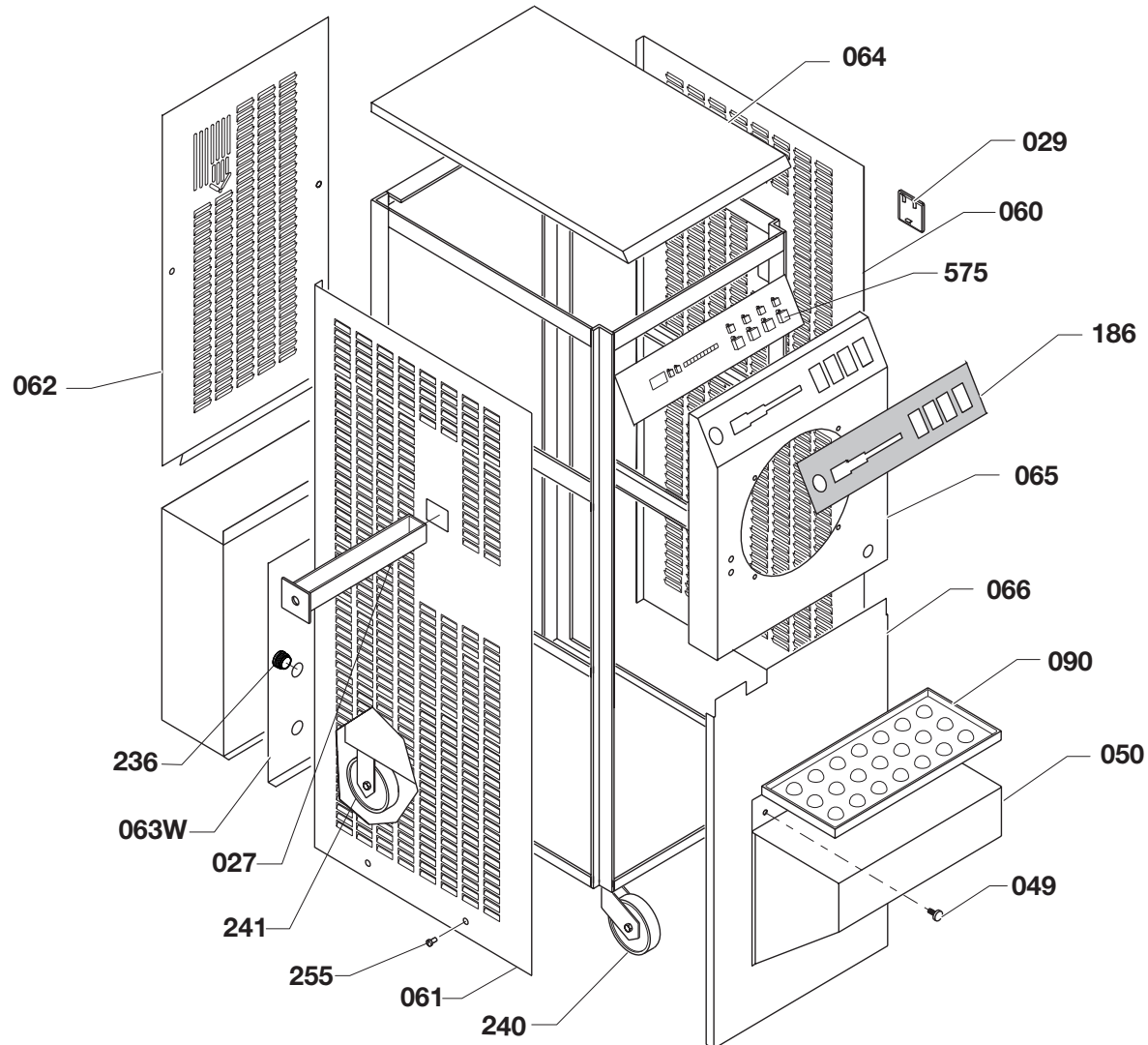

TRANSMISSIONE  
TRANSMISSION  
TRANSMISSION  
ANTRIEB  
TRANSMISIÓN

NUMERO TAVOLA  
TABLE NUMBER  
NUMÉRO DE TABLE  
TAFEL NR.  
NÚMERO DE TABLA

**02**

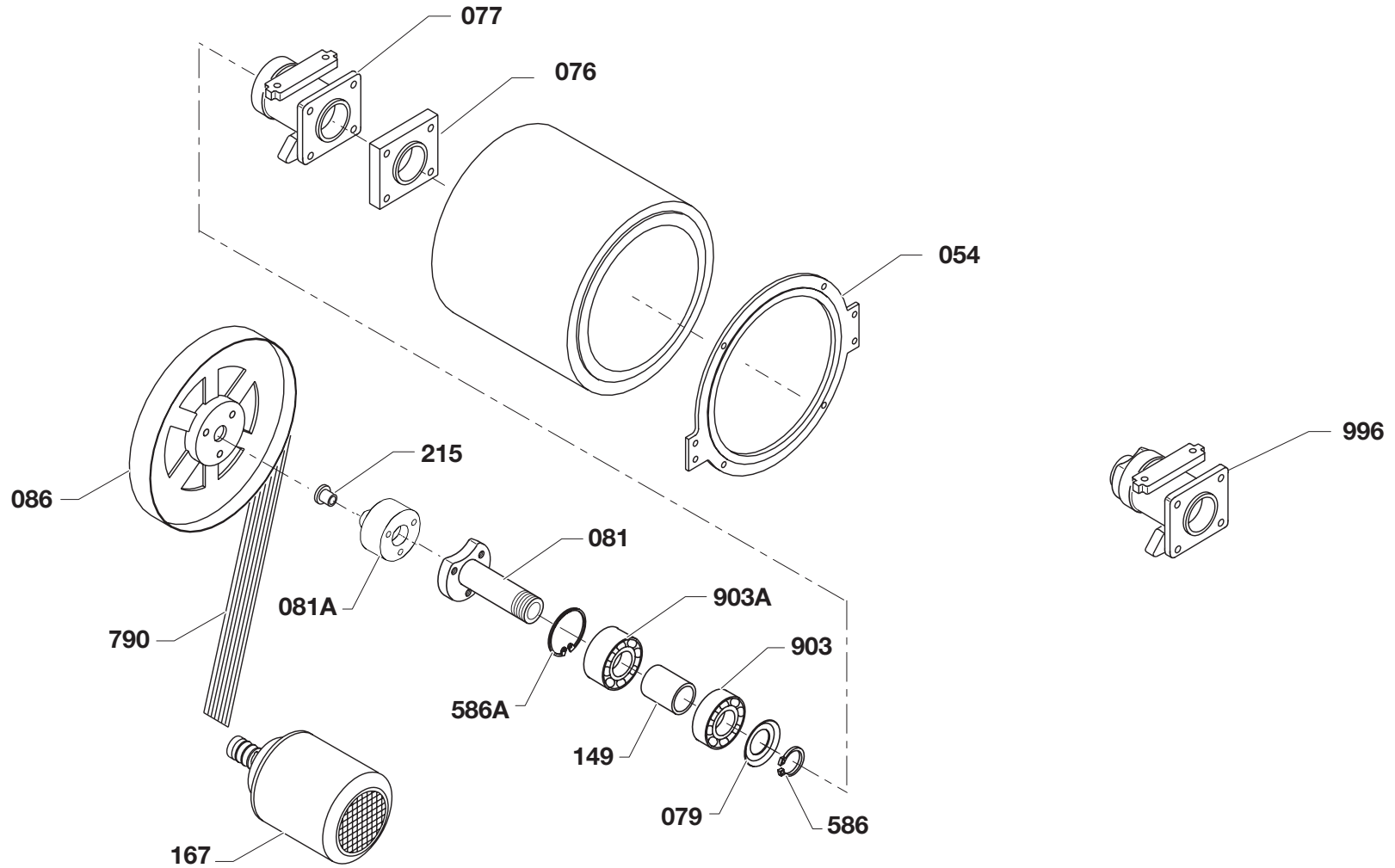

PORTELLO  
DOOR  
PORTILLON  
KLAPPE  
PORTILLO

NUMERO TAVOLA  
TABLE NUMBER  
NUMÉRO DE TABLE  
TAFEL NR.  
NÚMERO DE TABLA

**03**

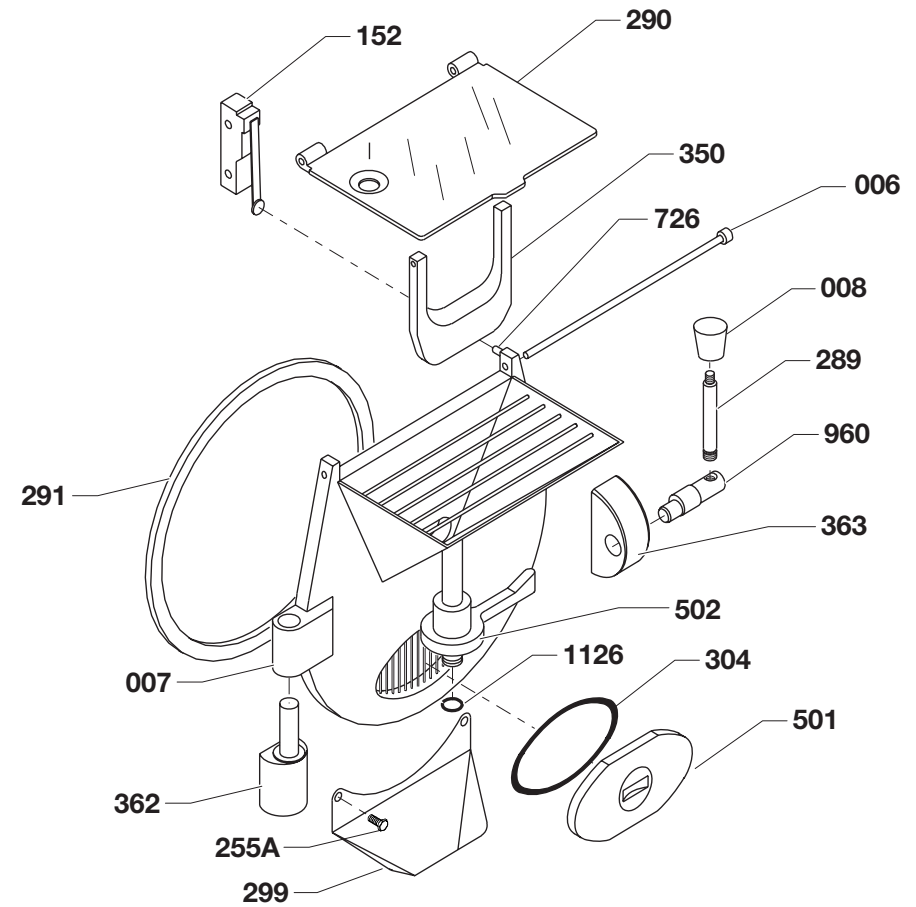
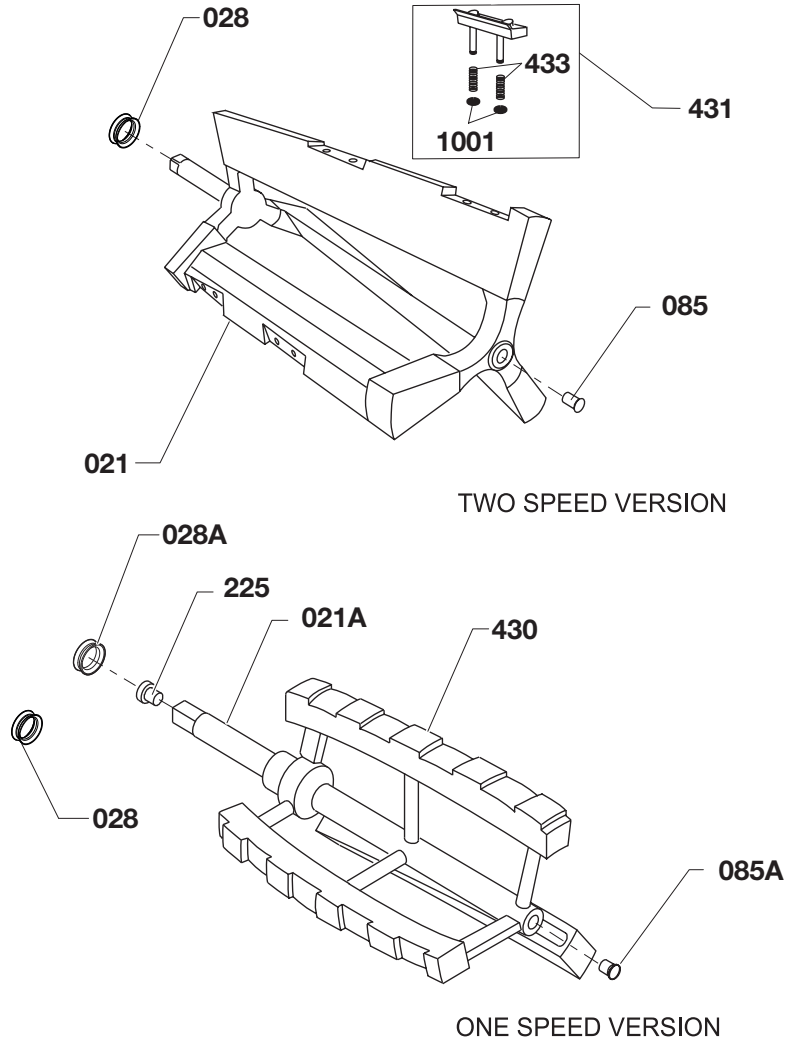

LAVAGGIO  
WASHING  
NETTOYAGE  
REINIGUNG  
LAVADO

NUMERO TAVOLA  
TABLE NUMBER  
NUMÉRO DE TABLE  
TAFEL NR.  
NÚMERO DE TABLA

**04**

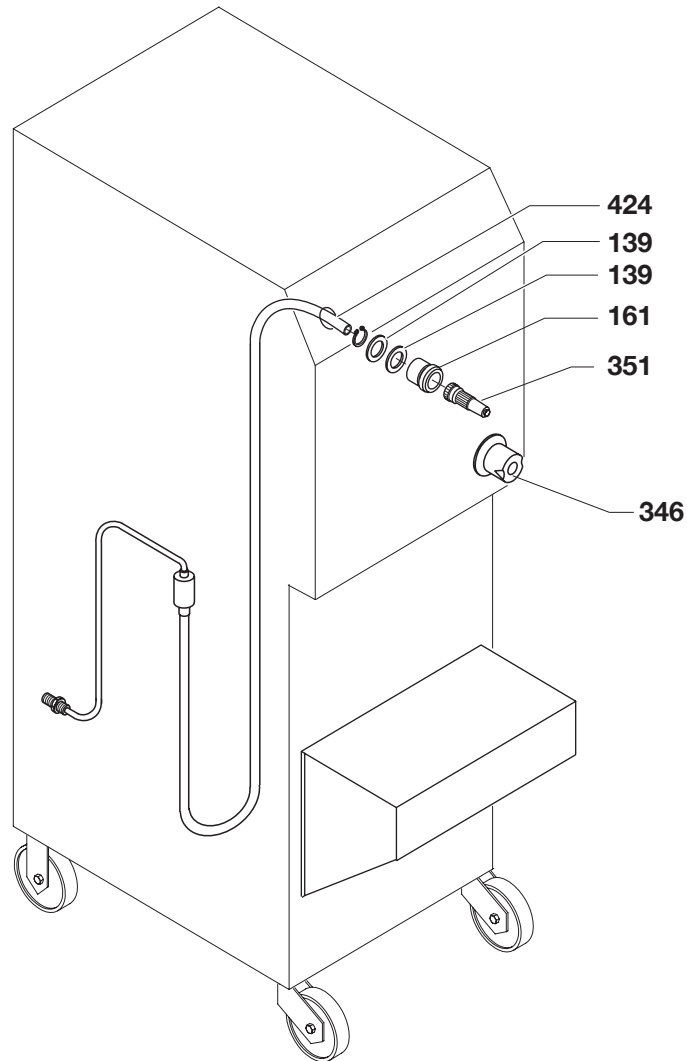

CASSETTA ELETTRICA  
ELECTRICAL BOX  
BOÎTE ÉLECTRIQUE  
ELEKTROKASTEN  
CAJA ELÉCTRICA

NUMERO TAVOLA  
TABLE NUMBER  
NUMÉRO DE TABLE  
TAFEL NR.  
NÚMERO DE TABLA

**05**

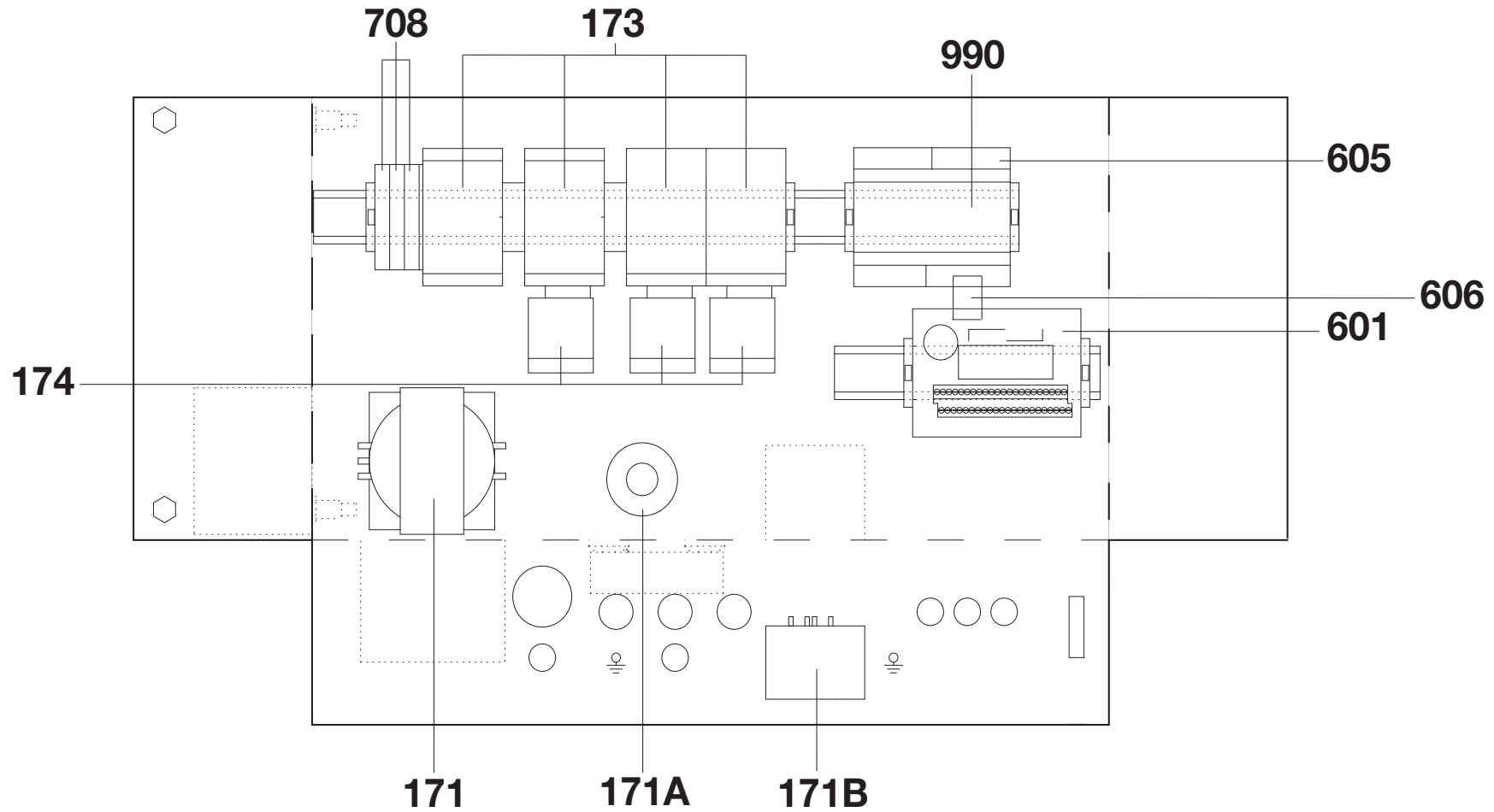



IMPIANTO FRIGORIFERO  
REFRIGERATING SYSTEM  
REFRIGERATEUR  
KÜHLANLAGE  
PLANTA REFRIGERADOR

NUMERO TAVOLA  
TABLE NUMBER  
NUMÉRO DE TABLE  
TAFEL NR.  
NÚMERO DE TABLA

**06**

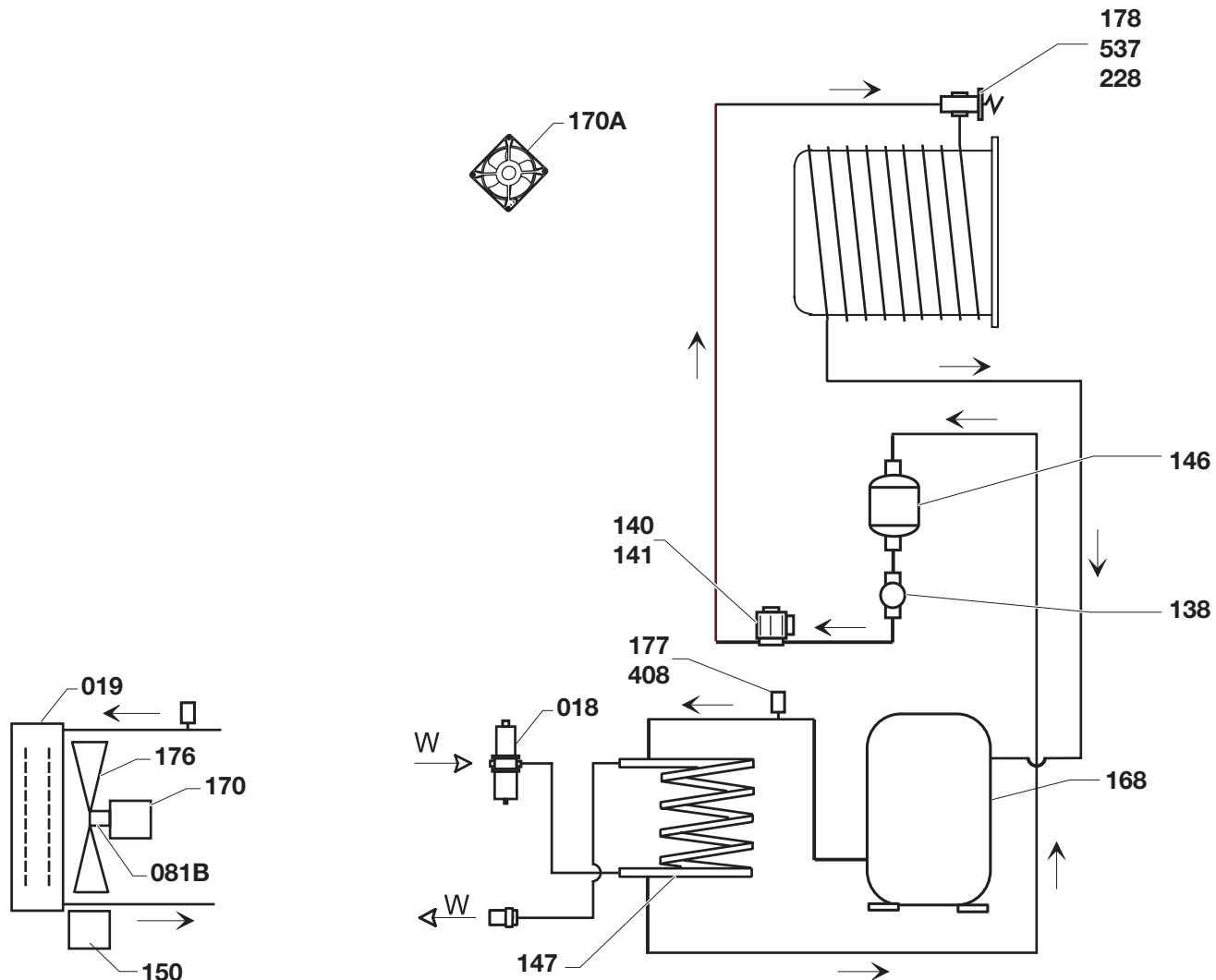

ACCESSORI A CORREDO  
ACCESSORIES KIT  
ACCESSOIRES D'ACCOMPAGNEMENT  
MITGELIEFERTES ZUBEHÖR  
ACCESORIOS DE ACOMPAÑAMIENTO

NUMERO TAVOLA  
TABLE NUMBER  
NUMÉRO DE TABLE  
TAFEL NR.  
NÚMERO DE TABLA

**07**

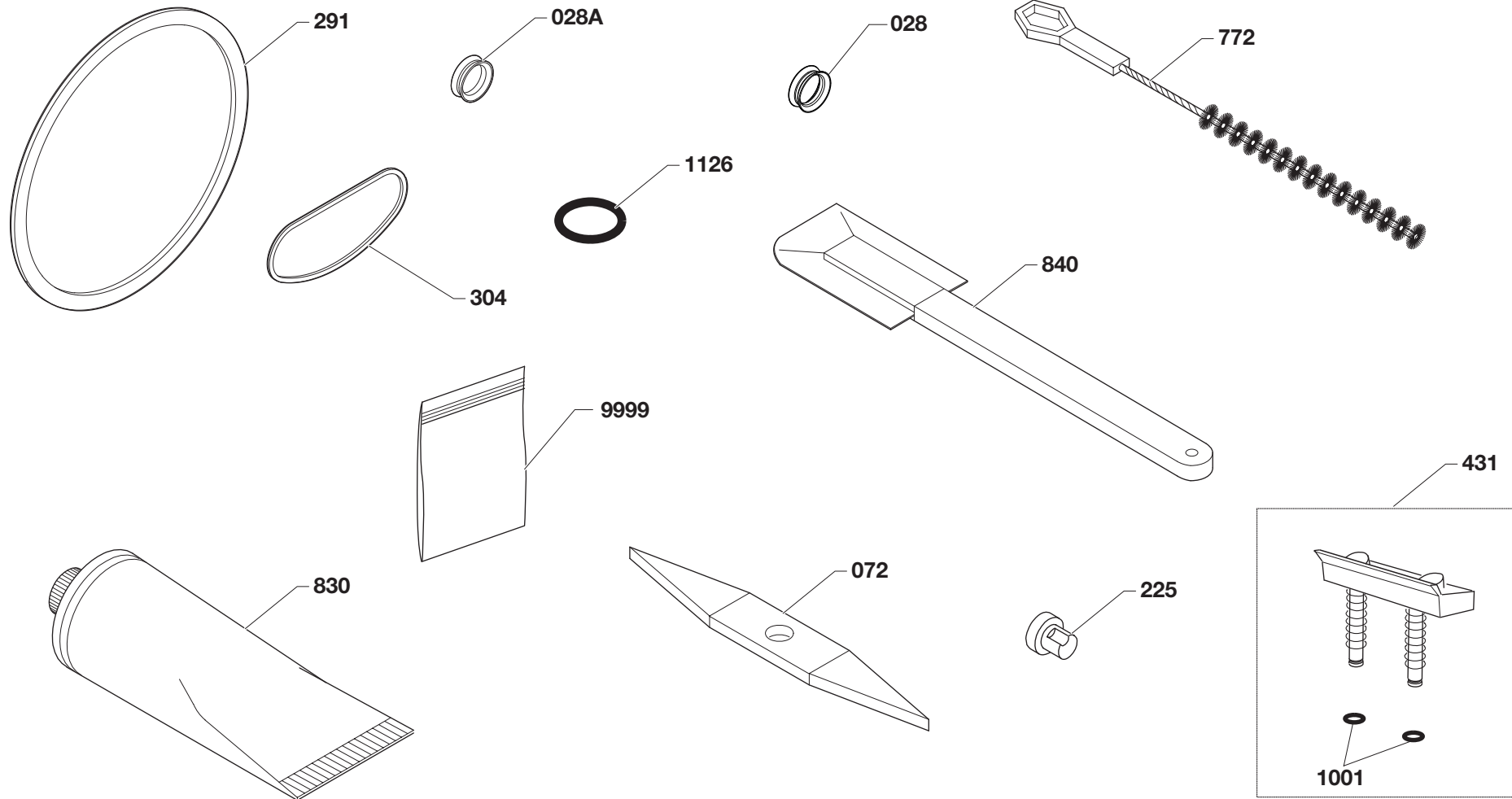

POS	CODE	IT	EN	DE	ES	FR
006	IC155161190	PERNO COPERCHIO BOCCA PORTELLO C/POMELLO	PIN-LID DOOR W/KNOB HAND	STIFT AUSLASSÖFFNUNG TÜR M.GRIFFKNOPF	PERNO TAPA BOCA PUERTA C/ POMO	BROCHE COUV. GOUPILLE PORT. AVEC POMMEAU
007	IC118130200	PORTELLO	DOOR	FRONTTÜR	PUERTA	PORTILLON
007	IC118130760	PORTELLO	DOOR	FRONTTÜR	PUERTA	PORTILLON
008	IC510300289	IMPUGNATURA ELESA 1.622/40-M8 RAL 9010	KNOB-HAND ELESA 1.622/40-M8 RAL 9010	GRIFF ELESA 1.622/40-M8 RAL 9010	EMPUÑADURA ELESA 1.622/40-M8 RAL 9010	POIGNEE ELESA 1.622/40-M8 RAL 9010
018	IC581800119	VALVOLA ACQUA 3/8"DANFOSS WVO10 003N6212	VALVE-WATER 3/8" DANFOSS WVO10 003N6212	WASSERVENTIL3/8"DANFOSS WVO10 003N6212	VÁLVULA AGUA3/8"DANFOSS WVO10 003N6212	SOUPAPE A EAU3/8"DANFOSS WVO10 003N6212
018	IC581800120	VALVOLA ACQUA 3/4"DANFOSS WVO20 003N6232	VALVE-WATER 3/4"DANFOSS WVO20 003N6232	WASSERVENTIL 3/4"DANFOSS WVO20 003N6232	VÁLVULA AGUA 3/4"DANFOSS WVO20 003N6232	SOUPAPE A EAU 3/4"DANFOSS WVO20 003N6232
019	IC131165100	CONDENSATORE ARIA ECO D55978	CONDENSER-AIR ECO D55978	LUFTKONDENSATOR ECO D55978	CONDENSADOR AIRE ECO D55978	CONDENSEUR A AIR ECO D55978
021	IC142050560	AGITATORE	DASHER	RÜHRWERK	AGITADOR	AGITATEUR
021A	IC142050420	AGITATORE 3E	DASHER 3E	RÜHRWERK 3E	AGITADOR 3E	AGITATEUR 3E
027	IC102159340	CASSETTINO SGOCCIOLO L=450	DRAWER DRIP L=450	ABTROPFKASTEN L=450	CAJETÍN GOTELO L=450	TIROIR EGOUITTOIR L=450
028	IC177120060	PREMISTOPPA AGITATORE HYTREL	SEAL-DRIVE SHAFT BEATER	STOPFBÜCHSE RÜHRWERK	PRENSAESTOPA AGITADOR	PRESSE ETOUPE AGITATEUR
028A	IC177120280	PREMISTOPPA AGITATORE SILICONE	SEAL-DRIVE SHAFT BEATER	STOPFBÜCHSE RÜHRWERK	PRENSAESTOPA AGITADOR	PRESSE ETOUPE AGITATEUR
028A	IC177120620	PREMISTOPPA AGITATORE GOMMA NERA	SEAL-DRIVE SHAFT BEATER (BLACK)	STOPFBÜCHSE RÜHRWERK	PRENSAESTOPA AGITADOR	PRESSE ETOUPE AGITATEUR
029	IC102164510	COPERCHIO FORO CASSETTINO BIANCO	COVER-DRAWER DRIP WHITE	DECKEL ÖFFNUNG ABTROPFKASTEN WEIß	TAPA ORIFICIO CAJETÍN BLANCO	COUVERCLE OUVERTURE TIROIR BLANC
049	IC171102830	BOTTONE ARRESTO MENSOLA	STUD SHELF MTG	ANSCHLAGKNOPF KONSOLE	BOTÓN PARA DETENCIÓN REPISA	GOUJON BLOCAGE CONSOLE
050	IC102132390	MENSOLA	SHELF	KONSOLE	REPISA	ETAGERE
054	IC158-000581	GUARNIZIONE ANTERIORE	RING CYL FRONT	DICHTUNG VORN	JUNTA DELANTERA	JOINT AVANT
060	IC102350490	LAM.LATERALE DX	PANEL-SIDE RIGHT	SEITENBLECH RECHTS	CHAPA LATERAL DERECHA	TOLE LATÉRALE DROITE
061	IC102360490	LAM.LATERALE SX	PANEL-SIDE LEFT	SEITENBLECH LINKS	CHAPA LATERAL IZQUIERDA	TOLE LATÉRALE GAUCHE
062	IC102115030	LAM.POSTERIORE SUPERIORE	PANEL-UPPER REAR	BLECH HINTEN OBEN	CHAPA TRASERA SUPERIOR	TOLE ARRIERE SUPERIEURE
063W	IC102119890	LAM.POSTERIORE INFERIORE W*1	PANEL-LOWER REAR WATER COOLED	BLECH HINTEN UNTEN WASSERKOND.	CHAPA TRASERA INF. AGUA	TOLE ARRIERE INF. EAU
064	IC102084380	LAM.SUPERIORE*1	PANEL-TOP	BLECH OBEN	CHAPA SUPERIOR	TOLE SUPERIEURE
065	IC102066730	LAM.FRONTALE SUPERIORE	PANEL-UPPER FRONT - LB502s, LABOs, & EfS	FRONTBLECH OBEN	CHAPA FRONTAL SUPERIOR	TOLE FRONTALE SUPERIEURE
066	IC102070430	LAM.FRONTALE INFERIORE*1	PANEL-LOWER FRONT	FRONTBLECH UNTEN	CHAPA FRONTAL INFERIOR	TOLE FRONTALE INFERIEURE
072	IC193010060	ESTRATTORE OR	EXTRACTOR O-RING	O-RING AUSHEBER	EXTRACTOR OR	EXTRACTEUR JOINTS TORIQUES
076	IC158210140	GUARNIZIONE MOVIMENTO POSTERIORE	GASKET REAR	DICHTUNG HINTERANTRIEB	JUNTA MOVIMIENTO TRASERO	JOINT DEPLACEMENT ARRIERE
077	IC164110130	SUPPORTO MOVIMENTO POSTERIORE	HOUSING BEARING & SHAFT	LAGERBOCK	SOPORTE MOVIMIENTO TRASERO	SUPPORT MOUVEMENT ARRIERE
079	IC158120040	ANELLO	RING	RING	ANILLO	JOINT
081	IC157155050	MOZZO	HUB §	NABE	CUBO	MOYEU - RTX 2060 COMP TOP
081A	IC157165130	MOZZO PULEGGIA D.90 X 52,5	HUB-AXIAL SHEAVE DIA.90 X 52,5	NABE RIEMENSCHLEIBE D.90 X 52,5	CUBO POLEA D.90 X 52,5	MOYEU POULIE D.90 X 52,5
081B	IC587110101	MOZZO DAYTON 2A564 D.INT.1/2"	HUB-DAYTON 2A564 D.INT.1/2"	NABE DAYTON 2A564 D.INT.1/2"	CUBO DAYTON 2A564 D.INT.1/2"	MOYEU DAYTON 2A564 D.INT.1/2"
085	IC155230330	PASTIGLIA ALBERO AGITATORE	PAD ANTI-FRICTION-FIT'S IC142060980	BELAG	PASTILLA	PASTILLE
085A	IC155230120	PASTIGLIA ALBERO AGITATORE	PAD ANTI-FRICTION	BELAG	PASTILLA	PASTILLE
086	IC153105010	PUL.ASS.45 J 390 95	SHEAVE AXIAL 45 J 390 95	RIEMENSCHLEIBE AXIAL	POLEA AXIAL	POULIE AXIAL
086	IC153105120	PUL.ASS.45 J 500 95	SHEAVE AXIAL 45 J 500 95	RIEMENSCHLEIBE AXIAL	POLEA AXIAL	POULIE AXIAL
090	IC158255820	APPOGGIO VASCHETTA PER MENSOLA	SUPPORT-PAN SHELF	SCHALENAUFNAHME F. KONSOLE	APOYO CUBETAS PARA REPISA	SUPPORT BACS POUR CONSOLE
138	IC581500121	SPIA LIQUIDO DANFOSS SGP 10 ODS x ODM	SIGHT GLASS DANFOSS SGP 10 ODS x ODM	SIGHT GLASS DANFOSS SGP 10 ODS x ODM	PILOTO LIQUIDO DANFOSS SGP 10 ODS x ODM	TEMOIN LIQUIDE DANFOSS SGP 10 ODS x ODM
139	IC173122400	ROSETTA PIANA 24 40 3,6 NYLON	WASHER-FLAT 24 40 3,6 NYLON	FLACHSCHEIBE 24 40 3,6 NYLON	ARANDELA PLANA 24 40 3,6 NYLON	RONDELLE PLATE 24 40 3,6 NYLON
140	IC581-001072	CORPO VALV.SOL.DANFOSS EVR 6 032L6238	BODY VALVE SOLENOID DANFOSS EVR 6	GEHÄUSE MAGNETVENTIL DANFOSS EVR 6	CUERPO VÁLVULA SOLENOIDE DANFOSS EVR 6	CORPS SOUPAPE SOLENOIDE DANFOSS EVR 6
141	IC581201042	BOBINA SOLEN.DANFOSS 24V-50/60 018F8270	COIL-DANFOSS 24V-50/60 018F8270	MAGNETSPULE DANFOSS 24V-50/60 018F8270	BOBINA SELENOIDE 24V-50/60 018F8270	BOBINE SOLENOIDE 24V-50/60 018F8270
146	IC581400115	FILTRO DANFOSS DML 163S 023Z4842	FILTER DRYER DANFOSS DML 163S 023Z4842	FILTER DANFOSS DML 163S 023Z4842	FILTRO DANFOSS DML 163S 023Z4842	FILTRE DANFOSS DML 163S 023Z4842
147	IC584200123	CONDENSATORE W HPCR 1167 TR 3/4"GAS	CONDENSER-WATER HPCR 1167 TR 3/4"GAS	WASSERKONDENSATOR HPCR 1167 TR 3/4"GAS	CONDENSADOR AGUA HPCR 1167 TR 3/4"GAS	CONDENSEUR A EAU HPCR 1167 TR 3/4"GAS
147	IC584200131	CONDENSATORE W WIELAND 846.10443 3/4"GAS	CONDENSER-WATER WIELAND 846.10443 3/4"	WASSERKONDENSATOR WIELAND 846.10443 3/4"	CONDENSADOR AGUA WIELAND 846.10443 3/4"	CONDENSEUR A EAU WIELAND 846.10443 3/4"
149	IC158155200	DISTANZIALE	SPACER	DISTANZSTÜCK	DISTANCIADOR	ENTRETOISE
150	IC574300101	COND.EL.MARCIA 5µF 370V NORME UL	CAPACITOR 5µF 370V "UL"	ELEKTR.KONDENSATOR 5µF 370V "UL"	CONDENSADOR ELÉCTRICO 5µF 370V "UL"	CONDENSEUR ELECTRIQUE 5µF 370V "UL"
152	IC133-002540	MICRO FRONTALE COMPLETO	MICROSWITCH-FRONT ASSEMBLY	MIKROSCHALTER-FRONTAL KOMPL.	MICROINTERRUPTOR FRONTAL COMPLETO	MICRO-INTERRUPTEUR FRONTAL COMPLET
161	IC157135090	BOCCOLA PASSATUBO 097207001	BUSHING	LEITUNGSDURCHFÜHRUNGSBUCHSE	CASQUILLO PASATUBO	DOUILLE PASSE-TUBE
167	IC193014010	KIT MOT.+PUL. IC552113010 IC153152370	KIT-MOT.+SHEAVE IC552113010 IC153152370	SATZ-MOT.+RIEM.IC552113010 IC153152370	KIT-MOT.+POLEA IC552113010 IC153152370	KIT-MOT.+POUL. IC552113010 IC153152370
167	IC193014336	KIT MOT.+PUL. IC551717542 IC153170680	KIT-MOT.+SHEAVE IC551717542 IC153170680	SATZ-MOT.+RIEM.IC551717542 IC153170680	KIT-MOT.+POLEA IC551717542 IC153170680	KIT-MOT.+POUL. IC551717542 IC153170680
167	IC193014353	KIT MOT.+PUL. IC552119311 IC153151910	KIT-MOT.+SHEAVE IC552119311 IC153151910	SATZ-MOT.+RIEM.IC552119311 IC153151910	KIT-MOT.+POLEA IC552119311 IC153151910	KIT-MOT.+POUL. IC552119311 IC153151910
167	IC193014357	KIT MOT.+PUL. IC551713043 IC153170900	KIT-MOT.+SHEAVE IC551713043 IC153170900	SATZ-MOT.+RIEM.IC551713043 IC153170900	KIT-MOT.+POLEA IC551713043 IC153170900	KIT-MOT.+POUL. IC551713043 IC153170900
167	IC193014459	KIT MOT.+PUL. IC551713072 IC153170900	KIT-MOT.+SHEAVE IC551713072 IC153170900	SATZ-MOT.+RIEM.IC551713072 IC153170900	KIT-MOT.+POLEA IC551713072 IC153170900	KIT-MOT.+POUL. IC551713072 IC153170900
167	IC193014460	KIT MOT.+PUL. IC552113010 IC153152350	KIT-MOT.+SHEAVE IC552113010 IC153152350	SATZ-MOT.+RIEM.IC552113010 IC153152350	KIT-MOT.+POLEA IC552113010 IC153152350	KIT-MOT.+POUL. IC552113010 IC153152350
167	IC193014461	KIT MOT.+PUL. IC552119340 IC153170010	KIT-MOT.+SHEAVE IC552119340 IC153170010	SATZ-MOT.+RIEM.IC552119340 IC153170010	KIT-MOT.+POLEA IC552119340 IC153170010	KIT-MOT.+POUL. IC552119340 IC153170010
167	IC193014462	KIT MOT.+PUL. IC551713043 IC153171180	KIT-MOT.+SHEAVE IC551713043 IC153171180	SATZ-MOT.+RIEM.IC551713043 IC153171180	KIT-MOT.+POLEA IC551713043 IC153171180	KIT-MOT.+POUL. IC551713043 IC153171180
168	IC561132840	C.COPELAND ZF13K4E-PFV-251 208230/60/1	C.COPELAND ZF13K4E-PFV-251 208230/60/1	K.COPELAND ZF13K4E-PFV-251 208230/60/1	C.COPELAND ZF13K4E-PFV-251 208230/60/1	C.COPELAND ZF13K4E-PFV-251 208230/60/1
168	IC561202733	C.BRISTOL L63A183DBDA 208230/60/3	COMPR.BRISTOL L63A183DBDA 208230/60/3	KOMPR.BRISTOL L63A183DBDA 208230/60/3	COMPR.BRISTOL L63A183DBDA 208230/60/3	COMPR.BRISTOL L63A183DBDA 208230/60/3
168	IC561222814	C.FRASCOLD F5-24 POE 200346/5060/3	COMPR.FRASCOLD F5-24 POE 200346/5060/3	KOMPR.FRASCOLD F5-24 POE 200346/5060/3	COMPRES.FRASCOLD F5-24 POE 200346/5060/3	COMPR.FRASCOLD F5-24 POE 200346/5060/3
168	IC561222911	C.FRASCOLD F7-28 POE 230400/50/3	COMPR.FRASCOLD F7-28 POE 230400/50/3	KOMPRESS.FRASCOLD F7-28 POE 230400/50/3	COMPRESOR FRASCOLD F7-28 POE 230400/50/3	COMPR.FRASCOLD F7-28 POE 230400/50/3
170	IC551710372	M.G.EL.5KCP29LG5858S 208230/60/1	MOTOR-FAN G.EL.5KCP29LG5858S 208230/60/1	MOTOR G.EL.5KCP29LG5858S 208230/60/1	MOTOR G.EL.5KCP29LG5858S 208230/60/1	MOTEUR G.EL.5KCP29LG5858S 208230/60/1
170	IC552-000178	M.VENT.EBM A6E500-AJ05-04 230/5060/1	MOTOR-FAN EBM A6E500-AJ05-04 230/5060/1	MOTORLÜFT.EBM A6E500-AJ05-04 230/5060/1	MOTOR VENT.EBM A6E500-AJ05-04 230/5060/1	MOTEUR EBM A6E500-AJ05-04 230/5060/1
170A	IC552290152	M.NMB 5915PC-23T-B30 230/5060/1	MOTOR-FAN NMB 5915PC-23T-B30 230/5060/1	MOTORLÜFT.NMB 5915PC-23T-B30 230/5060/1	MOTOR VENT.NMB 5915PC-23T-B30 230/5060/1	MOTEUR VEN.NMB 5915PC-23T-B30 230/5060/1
171	IC574100325	TRAS.F.1~ 75VA TA-1-81142 STANDARD	TRANSFORMER 1~ 75VA TA-1-81142 STANDARD	TRANSFORMATOR 1~ 75VA TA-1-81142	TRANSFORMADOR 1~ 75VA TA-1-81142	TRANSFORMATEUR 1~ 75VA TA-1-81142

POS	CODE	IT	EN	DE	ES	FR
171	IC574100328	TRASF.1~ 100VA 0-24/8,5-0-8,5/0-12	TRANSFORMER 1~ 100VA 0-24/8,5-0-8,5/0-12	TRANSFORMAT.1~ 100VA 0-24/8,5-0-8,5/0-12	TRANSFORMAD.1~ 100VA 0-24/8,5-0-8,5/0-12	TRANSFORMAT.1~ 100VA 0-24/8,5-0-8,5/0-12
171	IC574100338	TRASF.1~ 150VA 208-230/24V DONGAN	TRANSFORMER 1~ 150VA 208-230/24V DONGAN	TRANSFORMATOR 1~ 150VA 208-230/24V	TRANSFORMADOR 1~ 150VA 208-230/24V	TRANSFORMATEUR 1~ 150VA 208-230/24V
171A	IC574100302	TRASF.AMP.SIRIO 152050 RAPP.1/1000	TRANSFORMER SIRIO 152050 1/1000 \$	TRANSFORMATOR SIRIO 152050 1/1000	TRANSFORMADOR AMP. SIRIO 152050 1/1000	TRANSFORMATEUR AMP. SIRIO 152050 1/1000
171A	IC574100349	TRASF.AMP.CR MAGNETICS CR8450 1/1000 cUL	TRANSFORMER CR MAGNETICS CR8450 1/1000 c	TRANSFORMATOR CR MAGNETICS CR8450 1/1000	TRANSFORMADOR AMP. CR MAGNETICS CR8450	TRANSFORMATEUR AMP. CR MAGNETICS CR8450
171B	IC574100304	TRASF.1~ 30VA 24V/10,5-0-10,5/0-12	TRANSFORMER 1~ 30VA 24V/10,5-0-10,5/0-12	TRANSFORMAT.1~ 30VA 24V/10,5-0-10,5/0-12	TRANSFORMAD.1~ 30VA 24V/10,5-0-10,5/0-12	TRANSFORMAT.1~ 30VA 24V/10,5-0-10,5/0-12
173	IC571100172	CONTATTORE SCHNEIDER LC1 D12 B7 24V"UL"	CONTACTOR SCHNEIDER LC1 D12 B7 24V"UL"	SCHÜTZ SCHNEIDER LC1 D12 B7 24V"UL"	CONTACTOR SCHNEIDER LC1 D12 B7 24V"UL"	CONTACTEUR SCHNEIDER LC1 D12 B7 24V"UL"
173	IC571100174	CONTATTORE SCHNEIDER LC1 D18 B7 24V	CONTACTOR SCHNEIDER LC1 D18 B7 24V	SCHÜTZ SCHNEIDER LC1 D18 B7 24V	CONTACTOR SCHNEIDER LC1 D18 B7 24V	CONTACTEUR SCHNEIDER LC1 D18 B7 24V
173	IC571100176	CONTATTORE SCHNEIDER LC1 D25 B7 24V"UL"	CONTACTOR SCHNEIDER LC1 D25 B7 24V"UL"	SCHÜTZ SCHNEIDER LC1 D25 B7 24V"UL"	CONTACTOR SCHNEIDER LC1 D25 B7 24V"UL"	CONTACTEUR SCHNEIDER LC1 D25 B7 24V"UL"
173	IC571100177	CONTATTORE SCHNEIDER LC1 D32 B7 24V"UL"	CONTACTOR SCHNEIDER LC1 D32 B7 24V"UL"	SCHÜTZ SCHNEIDER LC1 D32 B7 24V"UL"	CONTACTOR SCHNEIDER LC1 D32 B7 24V"UL"	CONTACTEUR SCHNEIDER LC1 D32 B7 24V"UL"
174	IC571200175	TERMICO SCHNEIDER LRD 10 (4,0÷6,0)	THERMAL RELAY LRD 10 (4,0÷6,0)	THERMORELAIS LRD 10 (4,0÷6,0)	RELÉ TÉRMICO LRD 10 (4,0÷6,0)	RELAIS TERMIQUE LRD 10 (4,0÷6,0)
174	IC571200176	TERMICO SCHNEIDER LRD 12 (5,5÷8,0)	THERMAL RELAY LRD 12 (5,5÷8,0)	THERMORELAIS LRD 12 (5,5÷8,0)	RELÉ TÉRMICO LRD 12 (5,5÷8,0)	RELAIS TERMIQUE LRD 12 (5,5÷8,0)
174	IC571200177	TERMICO SCHNEIDER LRD 14 (7,0÷10)	THERMAL RELAY LRD 14 (7,0÷10)	THERMORELAIS LRD 14 (7,0÷10)	RELÉ TÉRMICO LRD 14 (7,0÷10)	RELAIS TERMIQUE LRD 14 (7,0÷10)
174	IC571200179	TERMICO SCHNEIDER LRD 21 (12,0÷18,0)	THERMAL RELAY LRD 21 (12,0÷18,0)	THERMORELAIS LRD 21 (12,0÷18,0)	RELÉ TÉRMICO LRD 21 (12,0÷18,0)	RELAIS TERMIQUE LRD 21 (12,0÷18,0)
174	IC571200180	TERMICO SCHNEIDER LRD 22 (16,0÷24,0)	THERMAL RELAY LRD 22 (16,0÷24,0)	THERMORELAIS LRD 22 (16,0÷24,0)	RELÉ TÉRMICO LRD 22 (16,0÷24,0)	RELAIS TERMIQUE LRD 22 (16,0÷24,0)
174	IC571200181	TERMICO SCHNEIDER LRD 32 (23,0÷32,0)	THERMAL RELAY LRD 32 (23,0÷32,0)	THERMORELAIS LRD 32 (23,0÷32,0)	RELÉ TÉRMICO LRD 32 (23,0÷32,0)	RELAIS TERMIQUE LRD 32 (23,0÷32,0)
176	IC133119010	VENTOLA COMPLETA D.500	BLADE FAN ASSY DIA.500	LAUFRAD KOMPL. D.500	ASPA COMPLETA D.500	VENTILATEUR COMPLETE D.500
177	IC583100134	PRESSOST.CC80 22/29 061F113000	CUT OUT PRESSURE CC80 22/29 061F113000	DRUCKSCHALTER CC80 22/29 061F113000	PRESOSTATO CC80 22/29 061F113000	PRESSOSTAT CC80 22/29 061F113000
178	IC581101054	VALV.TERM.TES2 MOP 30 06823438	VALVE-THERMOSTATIC TES2 MOP 30 06823438	THERMOSTATVENTIL TES2 MOP 30	VÁLVULA TERMOSTÁTICA TES2 MOP 30	DETENDEUR THERMOSTATIQUE TES2 MOP 30
186	IC192107600	DECALC.FRONTALE LABOTRONIC DGT LUNGA	DECAL-FRONT LABOTRONIC DGT	AUFKLEBER FRONTSEITE LABOTRONIC DGT	CALCOMANÍA FRONTAL LABOTRONIC DGT	DECALCOMANIE FRONTALE LABOTRONIC DGT
186	IC192113130	DECALC.FRONTALE LB 502	DECAL-FRONT LB 502	AUFKLEBER FRONTSEITE LB 502	CALCOMANÍA FRONTAL LB 502	DECALCOMANIE FRONTALE 502
186	IC192113480	DECALC.FRONTALE LB 502 BRUSTER'S	DECAL-FRONT LB 502 BRUSTER'S	AUFKLEBER FRONTSEITE LB 502 BRUSTER'S	CALCOMANÍA FRONTAL LB 502 BRUSTER'S	DECALCOMANIE FRONTALE 502 BRUSTER'S
186	IC192113560	DECALC.FRONTALE LB 502 HANDEL'S	DECAL-FRONT LB 502 HANDEL'S	AUFKLEBER FRONTSEITE LB 502 HANDEL'S	CALCOMANÍA FRONTAL LB 502 HANDEL'S	DECALCOMANIE FRONTALE 502 HANDEL'S
186	IC192114790	DECALC.FRONTALE LB 502 COLD STONE	DECAL-FRONT LB 502 COLD STONE	AUFKLEBER FRONTSEITE LB 502 COLD STONE	CALCOMANÍA FRONTAL LB 502 COLD STONE	DECALCOMANIE FRONTALE 502 COLD STONE
186	IC192115360	DECALC.FRONTALE LB 502 MAGGIE MOOS	DECAL-FRONT LB 502 MAGGIE MOOS	AUFKLEBER FRONTSEITE LB 502 MAGGIE MOOS	CALCOMANÍA FRONTAL LB 502 MAGGIE MOOS	DECALCOMANIE FRONTALE 502 MAGGIE MOOS
215	IC173135120	TAPPO CHIUSURA FORO MOZZO	PLUG-HUB	VERSCHLUSSSTOPFEN NABENÖFFNUNG	TAPÓN CIERRE ORIFICIO CUBO	BOUCHON FERMETURE TROU MOYEU
225	IC173135060	TAPPO TENUTA	PLUG-SEAL	DICHTSTOPFEN	TAPÓN ESTANQUEIDAD ECOWIP	BOUCHON D'ETANCHÉITE
228	IC589-002532	COPERTURA VALV.TERMOSTATICA	COVER-THERMOSTATIC VALVE	DECKEL THERMOSTATVENTIL	CUBIERTA VÁLVULA TERMOSTÁTICA	COUVERCLE SOUPAPE THERMOST.
236	IC588300356	TAPPO KAPSTO GPN 320 GL30	PLUG-KAPSTO GPN 320 GL30	STOPFEN KAPSTO GPN 320 GL30	TAPÓN KAPSTO GPN 320 GL30	BOUCHON KAPSTO GPN 320 GL30
240	IC591000213	RUOTA GIREV.D.100 NYLON BIANCO C/FRENO	CASTER-W/BRAKE DIA.100 WHITE NYLON	DREHBARES RAD D.100 NYLON WEIß + BREMSE	RUEDA GIRATORIA D.100 NYLON BLANCO+FRENO	ROUE PIVOTANTE D.100 NYLON BLANC + FREIN
241	IC591000113	RUOTA FISSA D.100 NYLON BIANCO	CASTER-W/O BRAKE DIA.100 WHITE NYLON	FESTSTEHENDES RAD D.100 NYLON WEIß	RUEDA FIJA D.100 NYLON BLANCO	ROUE FIXE D.100 NYLON BLANC
255	IC511528510	VITE TCCI M 5X 10 DIN85 A2	HEXAGON SOCKET HEAD CAP SCREW M3x10	SCHRAUBE M 5X 10 DIN85 A2	TORNILLO M 5X 10 DIN85 A2	VIS M 5X 10 DIN85 A2
255A	IC171100470	VITE CHIUSURA FORI FRONTALI	SCREW-SEALING FRONT HOLES	VERSCHLUSSSCHRAUBE BOHRUNGEN FRONTS.	TORNILLO CIERRE ORIFICIOS FRONTALES	VIS FERMETURE TROUS FRONTALS
289	IC151560160	LEVA COMANDO ECCENTRICO	HANDLE CAMLOCK	EXZENTERHEBEL	PALANCA MANDO EXCÉNTRICA	LEVIER COMMANDE EXCENTRIQUE
290	IC158261470	COPERCHIO BOCCA PORTELLO	LID-DOOR	DECKEL TÜROFFNUNG	TAPA BOCA PUERTA	COUVERCLE GOUPILLE PORTILLON
290	IC158262180	COPERCHIO BOCCA PORTELLO	LID-DOOR	DECKEL TÜROFFNUNG	TAPA BOCA PUERTA	COUVERCLE GOUPILLE PORTILLON
291	IC158200090	GUARNIZIONE PORTELLO	GASKET DOOR	TÜRDICHTUNG	JUNTA PUERTA	JOINT PORTILLON
299	IC102167150	SGOCCIOLIO	TRAY-DRIP	TROPFBLECH	GOTEO	EGOUTTOIR
299	IC102167410	SGOCCIOLIO	TRAY-DRIP	TROPFBLECH	GOTEO	EGOUTTOIR
304	IC158200710	GUARNIZIONE PORTELLINO SCARICO GELATO	SEAL-DOOR DISPENSE	DICHTUNG EISAUSLASSKLAPPE	JUNTA PUERTA SALIDA HELADO	JOINT PORTILLON SORTIE CREME GLACEE
346	IC589100204	RUBINETTO 3/8 ART.174 SATINATO	TAP-WATER 3/8 ART.174 GLAZED	WASSERHAHN 3/8 ART.174	GRIFO AGUA 3/8 ART.174	ROBINET EAU 3/8 ART.174
350	IC158262190	PORTELLO CHIUSURA BOCCA	DOOR-LOCK DOOR	VERSCHLUSSKLAPPE TÜROFFNUNG	PUERTA CIERRE BOCA PUERTA	PORTILLON FERMETURE GOULOTTE PORTILLON
351	IC157220690	TERMINALE TUBO EROGAZIONE ACQUA	NOZZLE-WATER	ENDSTÜCK WASSERABGABEROHR	TERMINAL TUBO DISTRIBUCIÓN AGUA	BORNE TUBE DISTRIBUTION EAU
362	IC164100230	SUPPORTO PORTELLO	HINGE-DOOR	HALTERUNG FRONTTÜR	SOPORTE PUERTA	SUPPORT PORTILLON
363	IC164100240	SUPPORTO ECCENTRICO	SUPPORT-CAM DOOR	EXZENTERHALTERUNG	SOPORTE EXCÉNTRICO	SUPPORT EXCENTRIQUE
408	IC581300525	VALVOLA DI SERVIZIO COMPLETA	VALVE-SERVICE ASSEMBLY	BETRIEBSVENTIL KOMPL.	VÁLVULA SERVICIO COMPLETA	SOUPAPE SERVICE COMPLETE
424	IC589110031	TUBO DOCCIA MONOFORO MF 3/8" L=2M	HOSE-FLEXIBLE 3/8" MALE/FEMALE 2m-6FOOT	SCHLAUCH 3/8" AUSSENGEW./INNENGEW. 2m	TUBO FLEXIBLE 3/8" MACHO/HEMBRA 2m	TUBE FLEXIBLE 3/8" MALE/FEMELLE 2m
430	IC680402144	ALETTA L=390 STP	SCRAPER-390mm	FLÜGEL 390mm	ALETA 390mm	AILETTE 390mm
431	IC141125690	PLACCA AUTOREGOLANTE SA	SCRAPER SELF ADJUSTING SA	ABSTREIFER SELBSTREGELND SA	PLACA AUTORREGULADORA SA	PLAQUE AUTOREGULATRICE SA
433	IC178101240	MOLLA C 1,125 8,4 43 7,1	SPRING C 1,125 8,4 43 7,1	FEDER C 1,125 8,4 43 7,1	MUELLE C 1,125 8,4 43 7,1	RESSORT C 1,125 8,4 43 7,1
501	IC118125050	PORTELLINO SCARICO GELATO	DOOR-DISPENSE	EISAUSLASSKLAPPE	BOCA DE SALIDA HELADO	PORTILLON EVACUATION GLACES
502	IC161150090	ECCENTRICO PORTELLO SCARICO	HANDLE DISPENSE DOOR	EXZENTER ABLASSKLAPPE	EXCÉNTRICA PORTILLA DESCARGA	EXCENTRIQUE PORTILLON EVACUATION
537	IC581110614	ORIFICO DANFOSS N° 04 068-2084	ORIFICE DANFOSS N° 04 068-2084	ÖFFNUNG DANFOSS N° 04 068-2084	ORIFICIO DANFOSS N° 04 068-2084	ORIFICE DANFOSS N° 04 068-2084
575	IC573800580	PULSANT.MOD.LABO DGT + FERRITE	PUSH-BUTTON PANEL LABO DGT W/FERRITE	TASTATUR LABO DGT MIT FERRIT	BOTONERA LABO DGT CON FERRITA	CLAVIER LABO DGT AVEC FERRITE
586	IC519000145	ANELLO EL.SIC.45 UNI7435 C70	RING-RETAINING DIA.45 UNI7435 C70	SEEGERRING 45 UNI7435 C70	ANILLO ELÁSTICO 45 UNI7435 C70	JOINT ELASTIQUE 45 UNI7435 C70
586A	IC519000285	ANELLO EL.SIC.85 UNI7437 C70	RING-RETAINING DIA.85 UNI7437 C70	SEEGERRING 85 UNI7437 C70	ANILLO ELÁSTICO 85 UNI7437 C70	JOINT ELASTIQUE 85 UNI7437 C70
601	IC573800145	SCHEDA 5 RELE'C/BEEP MOPRO R&D	ELECTRONIC BOARD-5 RELAY+BEEP MOPRO R&D	ELEKTRONISCHE KARTE 5 RELAIS+BEEP MOPRO	PLACA ELECTRÓNICA 5 RELÉ+BEEP MOPRO R&D	CARTE ELECTRONIQUE 5 RELAIS+BEEP MOPRO
605	IC573700194	CENTRAL.MOPRO PTC (130°) NTC R&D	ELECTRONIC BOARD MOPRO PTC(130°)NTC R&D	ELEKTRONISCHE STEUERUNG PTC(130°)NTC R&D	CENTRALITA ELECTRÓNICA MOPRO PTC (130°)	CENTRALE ELECTRONIQUE MOPRO PTC(130°)NTC
606	IC577400503	CAVO FLAT SFT DGT 0,3m	WIRE-FLAT SFT DGT 0,3m	FLACHKABEL SFT DGT 0,3m	CABLE PLANO SFT DGT 0,3m	CÂBLE PLAT SFT DGT 0,3m
708	IC576200225	FUSIBILE 2A 250V IR10,000A UL-CSA	FUSE 2A 250V IR10,000A UL-CSA	SCHMELZSICHERUNG 2A 250V IR10,000A ULCSA	FUSIBLE 2A 250V IR10,000A UL-CSA	FUSIBLE 2A 250V IR10,000A UL-CSA
708	IC576200226	FUSIBILE 3,5A 250V IR10,000A UL-CSA	FUSE 3,5A 250V IR10,000A UL-CSA	SCHMELZSICHERUNG 3,5A 250V IR10,000A UL-	FUSIBLE 3,5A 250V IR10,000A UL-CSA	FUSIBLE 3,5A 250V IR10,000A UL-CSA
708	IC576200287	FUSIBILE OMEGA SF 5X20 F 4A 250V	FUSE OMEGA SF 5X20 F 4A 250V	SCHMELZSICHERUNG OMEGA SF 5X20 F 4A 250V	FUSIBLE OMEGA SF 5X20 F 4A 250V	FUSIBLE OMEGA SF 5X20 F 4A 250V
708	IC576200288	FUSIBILE OMEGA SF 5X20 F 5A 250V	FUSE OMEGA SF 5X20 F 5A 250V	SCHMELZSICHERUNG OMEGA SF 5X20 F 5A 250V	FUSIBLE OMEGA SF 5X20 F 5A 250V	FUSIBLE OMEGA SF 5X20 F 5A 250V
708	IC576200293	FUSIBILE OMEGA ST 5X20 T 1,25A 250V	FUSE OMEGA ST 5X20 T 1,25A 250V	SCHMELZSICHERUNG ST 5X20 T 1,25A 250V	FUSIBLE OMEGA ST 5X20 T 1,25A 250V	FUSIBLE OMEGA ST 5X20 T 1,25A 250V

POS	CODE	IT	EN	DE	ES	FR
708	IC576200297	FUSIBILE OMEGA ST 5X20 T 2A 250V	FUSE OMEGA ST 5X20 T 2A 250V	SCHMELZSICHERUNG ST 5X20 T 2A 250V	FUSIBLE OMEGA ST 5X20 T 2A 250V	FUSIBLE OMEGA ST 5X20 T 2A 250V
726	IC155161180	PERNO COMANDO MICRO	PIN-MICROSWITCH	BETÄTIGUNGSTIFT MIKROSCHALTER	PERNO MANDO MICRO	BROCHE COMMANDE MICRO
772	IC599100115	SCOVOLINO D. 15X350	BRUSH FINE DIA. 15X350	REINIGUNGSBÜRSTE D. 15X350	ESCOBILLA D. 15X350	ECOUVILLON D. 15X350
790	IC531300148	CINGHIA POLY V 1752 J69 30N	BELT POLY V 1752 J69 30N	RIEMEN POLY V 1752 J69 30N	CORREA POLY V 1752 J69 30N	COURROIE POLY V 1752 J69 30N
790	IC531300156	CINGHIA POLY V 1613 L63,5 16N	BELT POLY V 1613 L63,5 16N	RIEMEN POLY V 1613 L63,5 16N	CORREA POLY V 1613 L63,5 16N	COURROIE POLY V 1613 L63,5 16N
790	IC531300161	CINGHIA POLY V 1841 L72,5 16N	BELT POLY V 1841 L72,5 16N	RIEMEN POLY V 1841 L72,5 16N	CORREA POLY V 1841 L72,5 16N	COURROIE POLY V 1841 L72,5 16N
830	IC743000104	TUBETTO CARPILUBE BATCH FREEZERS g.113	TUBE-CARPILUBE BATCH FREEZERS g.113 §	TUBE-CARPILUBE BATCH FREEZERS g.113	TUBO CARPILUBE BATCH FREEZERS g.113	TUBE CARPILUBE BATCH FREEZERS g.113
840	IC178-000283	SPATOLA PULIZIA	SPATULA	SPATEL	PALETA	SPATULE
903	IC521111300	CUSCINETTO RIV 3209-2RS1	BEARING RIV 3209-2RS1	KUGELLAGER RIV 3209-2RS1	RODAMIENTO RIV 3209-2RS1	COUSSINET RIV 3209-2RS1
903A	IC521111337	CUSCINETTO RIV 6209-2RS1	BEARING RIV 6209-2RS1	KUGELLAGER RIV 6209-2RS1	RODAMIENTO RIV 6209-2RS1	COUSSINET RIV 6209-2RS1
960	IC161130110	ECCENTRICO CHIUSURA PORTELLO	CAM LOCK DOOR	EXZENTER TÜRVERSCHLUSS	EXCÉNTRICA CIERRE PUERTA	EXCENTRIQUE FERMETURE PORTILLON
990	IC573810105	FLASH EPROM VER.LABOSD05.BIN	FLASH EPROM VER.LABOSD05.BIN	FLASH EPROM VER.LABOSD05.BIN	FLASH EPROM VER.LABOSD05.BIN	FLASH EPROM VER.LABOSD05.BIN
990	IC573810130	FLASH EPROM VER.LABOSD12.BIN	FLASH EPROM VER.LABOSD12.BIN	EPROM	EPROM	EPROM
990	IC573810256	FLASH EPROM VER.LABOSD11.BIN	FLASH EPROM VER.LABOSD11.BIN	FLASH EPROM VER.LABOSD11.BIN	FLASH EPROM VER.LABOSD11.BIN	FLASH EPROM VER.LABOSD11.BIN
996	IC157080290	MOVIMENTO POSTERIORE CONDOTTO COMPLETO	ASSEMBLY SHAFT DRIVE	GETRIEBENE NABE KPL.	MOVIMIENTO TRASERO CONDUCCIDO COMPLETO	DEPLAC.ARR.CONDUIT COMPLET
1101	IC541000101	OR 1,78 2,9 NBR70 693/72 2012	O-RING 1,78 2,9 NBR70 693/72 2012	O-RING 1,78 2,9 NBR70 693/72 2012	JUNTA TÓRICA 1,78 2,9 NBR70 693/72 2012	JOINT TORIQ. 1,78 2,9 NBR70 693/72 2012
1126	IC541000126	OR 2,62 13,95 NBR70 693/72 3056	O-RING 2,62 13,95 NBR70 693/72 3056	O-RING 2,62 13,95 NBR70 693/72 3056	JUNTA TOR. 2,62 13,95 NBR70 693/72 3056	JOINT TOR. 2,62 13,95 NBR70 693/72 3056
9999	IC193-010254	CARPICARE KIT LABO XPL-XPL/P-DGT	CARPICARE KIT LABO XPL-XPL/P-DGT	CARPICARE KIT LABO XPL-XPL/P-DGT	CARPICARE KIT LABO XPL-XPL/P-DGT	CARPICARE KIT LABO XPL-XPL/P-DGT
9999	IC193014335	KIT LABO/LB COPERCHI PORTELLO	KIT-LABO/LB-DOOR LID AND GUARD SPLASH	SATZ-LABO/LB-DECKEL FÜR FRONTTÜR	KIT-LABO/LB TAPA PARA PUERTA	KIT-LABO/LB COUVERCLE POUR PORTILLON
9999	IC193014420	KIT VENTOLA+MOZZO 587-002230 587110101	KIT-FAN BLDE+HUB 587-002230 587110101	SATZ LAUFRAD+ NABE 587-002230 587110101	KIT ASPA+CUBO 587-002230 587110101	KIT VENTILATEUR+MOYEU 587-002230 5871101



**CARPIGIANI GROUP**

Via Emilia, 45

40011 Anzola dell'Emilia (BO) Italy

tel.+39 051 6505111

☎ +39 051 732178

🌐 <http://www.carpigiani.com>