



ItalCart P

Case Features:

- Pozzetti-Style of ItalCart!
- Stainless Steel Frame
- Two Large Back Wheels and One Front Wheel for Easy Movement
- Each Cart Can Be Customized With Your Colors and Branding
- *Optional Electrical: 115V / 1Phase/60Hz/15 Amp (Must be specified upon ordering)



Plug Type

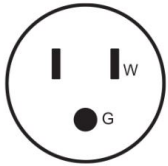

5-15P

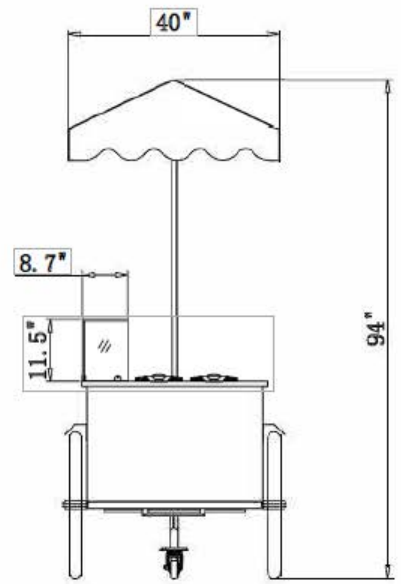
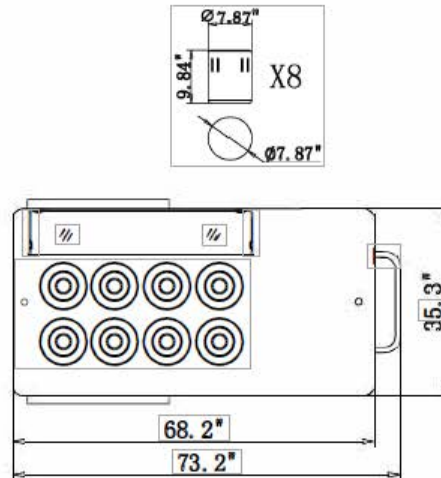
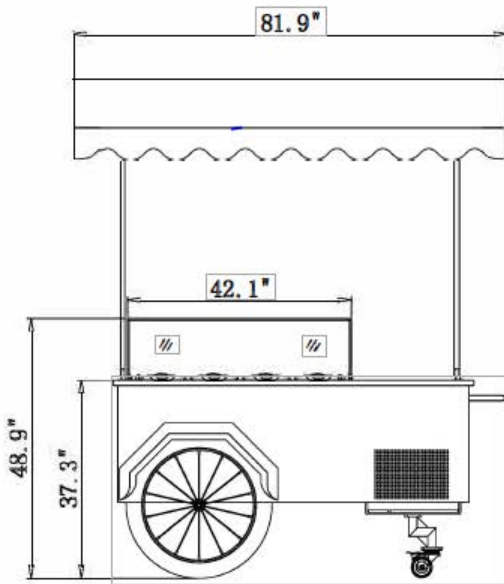

DISPLAY CASES

Model	Carapinas	Width	Depth	Height	Electrical Requirements
ItalCartP	8	82"	40"	94"	220V/1Phase/60Hz/10 Amp