



EURO

Flat Lid Display Freezer and
Ice Cream Freezer

KEY ASPECTS

SPECIAL FEATURES:

- Five popular sizes
- Dual condensing system
- Environmentally friendly hydrocarbon refrigerant

OPTIONS:

- 3 section hanging baskets
- Wide range thermostat
- Lid lock
- 3 gallon can holders

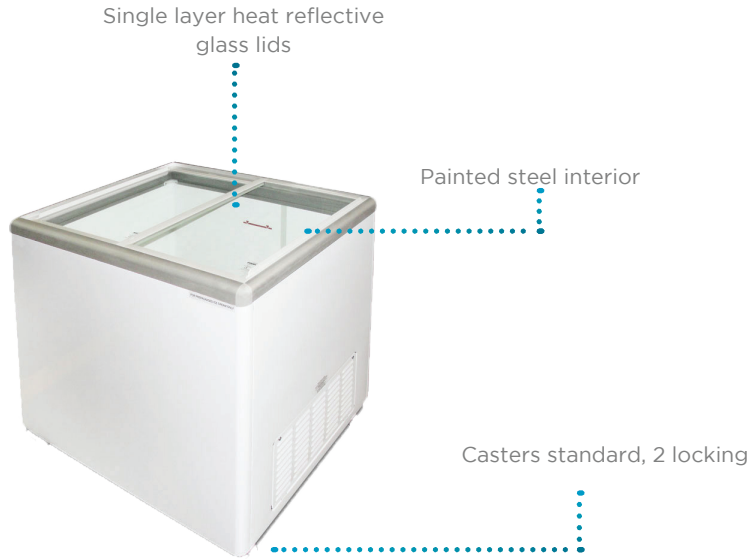

Complies with 2017 DOE standards for commercial freezer and ice cream freezer

TECHNICAL SUMMARY

MODEL	SIZE				ELECTRICAL		REFRIGERATION			OTHER		
	Dimensions (inches)* Width x Depth x Height	Cubic Feet	Net Weight (lbs.)	Shipping Weight (lbs.)**	Voltage/Hz/Phase	Running Amps	Compressor HP	Refrigerant	Temperature	Capacity 3 Gallon Cans	No. of Optional Baskets	Container Quantity
EURO-5HC	24 5/8 x 24 5/8 x 33 7/8	5.0	110	120	115/60/1	1.2	1/5	R-290	-15°F to +25°F	4/2	2	153
EURO-8HC	33 3/8 x 24 5/8 x 33 7/8	7.5	121	140	115/60/1	1.2	1/5	R-290	-15°F to +25°F	4/2	3	129
EURO-10HC	39 5/8 x 24 5/8 x 33 7/8	9.6	136	157	115/60/1	1.4	1/4	R-290	-15°F to +25°F	6/4	4	102
EURO-13HC	47 1/2 x 24 5/8 x 33 7/8	12.5	163	174	115/60/1	1.3	1/4	R-290	-15°F to +25°F	8/6	5	84
EURO-16HC	59 3/8 x 24 5/8 x 33 7/8	15.5	183	197	115/60/1	1.5	1/4	R-290	-15°F to +25°F	10/8	6	72

*Dimensions are all nominal lengths

**Does not include weight of pallets when needed

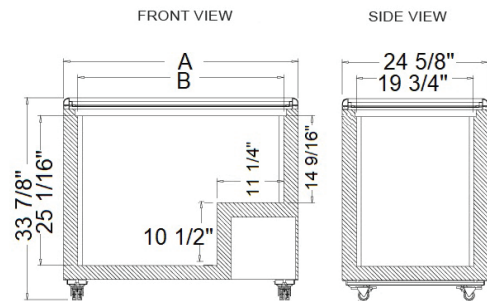

	A	B
EURO-5HC	24 5/8"	19 3/4"
EURO-8HC	33 3/8"	28 1/2"
EURO-10HC	39 5/8"	34 3/4"
EURO-13HC	47 1/2"	42 5/8"
EURO-16HC	59 3/8"	54 1/2"