



Flavor Rail Cabinets

Perfect preservation of product quality and flavor...continuous failure-free operation that virtually eliminates maintenance...absolute minimum of operating costs...these are the advantages offered by Nelson's superior design and construction which can only be measured over long periods in terms of service and value. Since 1898, the industry's finest equipment for the protection of quality and flavor in ice cream and frozen foods. Now, with the lowest prices on the internet, see Nelson for the best deals on ice cream dipping equipment. For a serious Ice Cream Business, experienced or start-up, you need a Nelson Dipping Cabinet



SPECIFICATIONS: One piece 22 ga. 304 stainless steel, all corners welded (no corner pieces or raw edges, ever), Galvanized steel reinforced sub-top beneath the stainless top, Anti-condensate heater wires on galvanized sub-top to prevent condensation on cabinet top, 24 ga stainless steel interior. Optional 22 ga. 304 stainless steel exterior, Copper tubing cold wall type evaporator attached to liner wall, Forced air condensing unit (clog free design on all BD models) on glide-out base for efficient operation and built-in applications, Base of cabinet to be constructed of 16 ga. Galvanized steel, Poured-in place urethane foam insulation with a minimum "K" factor of .13, Lids to be stainless steel top with poured urethane foam insulation and hinged in the center with rubber handles, Cabinet to be equipped with a 7-ft power cord, 3 wire, grounded, dead front construction, Unit NSF & ETL approved.

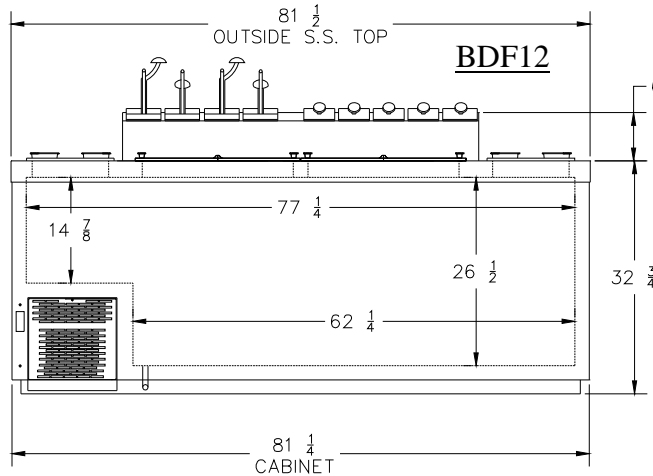
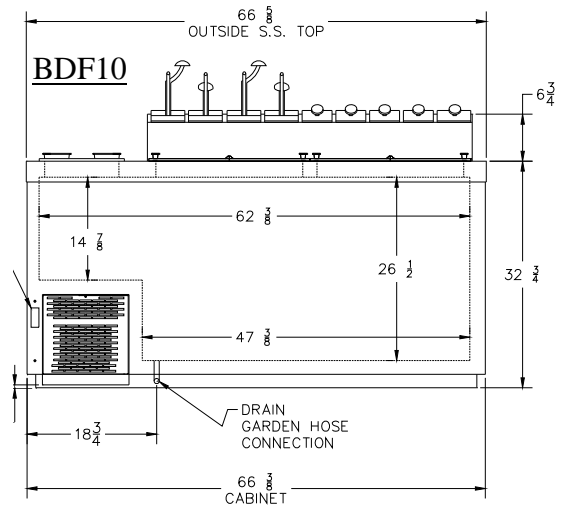
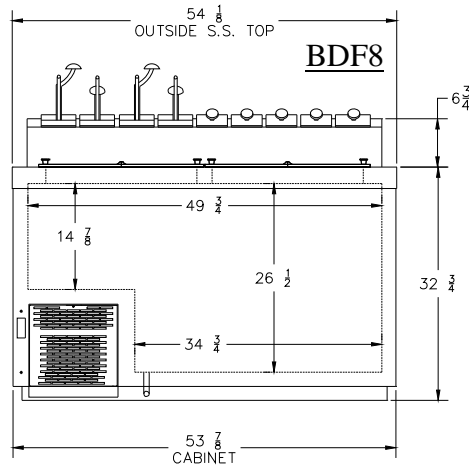
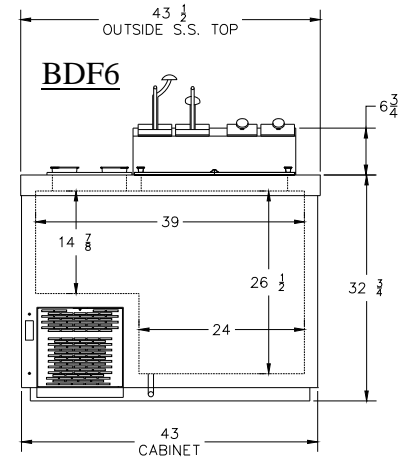
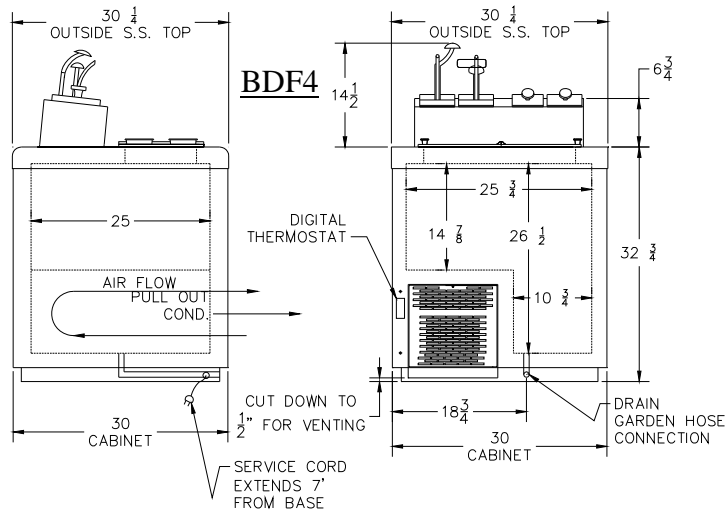

| Specifications | BDF4 | BDF6 | BDF8 | BDF10 | BDF12 |
|----------------|--------|--------|--------|--------|--------|
| SHIP WT. | 260 | 325 | 345 | 370 | 430 |
| CuFt FREEZER | 7.5 | 13 | 17.5 | 23 | 28 |
| TOTAL TUBS | 7 | 13 | 19 | 25 | 33 |
| Refridgerant | R290 | R290 | R290 | R290 | R290 |
| COMPRESSOR | 1/3 HP | 1/3 HP | 1/3 HP | 1/3 HP | 1/2 HP |
| AMPS | 8 | 8 | 8 | 8 | 11 |
| ELECTRIC | 115 v. | 115v. | 115v | 115v | 115v |

Optional Pump, Jar & Ladle Kits are available and sold as kits or individually. The BDF Series have insulation in the jar rack and receives cold air from the freezer to hold 42-52 degrees. The JR Models have no insulation in the jar rack and holds the ambient temperature.

Flavor Rail cabinets are finished with a white baked enamel finish or an optional stainless exterior.