

dipperwell

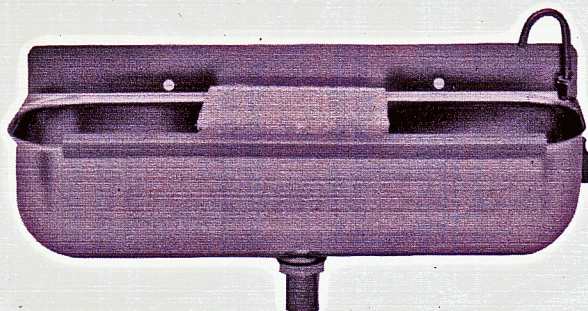

PWV-16

STAINLESS STEEL HEAVY 304 GAUGE - WATER VALVE - VINYL COVERED EDGE - REMOVABLE STAINLESS STEEL WIRE SPONGE HOLDER - ONE PIECE

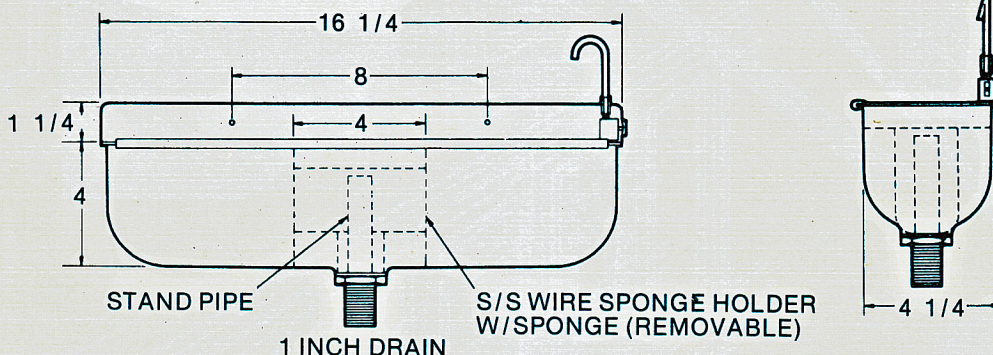

NOTE: ALL DIMENSIONS SHOWN ARE IN INCHES

FOUNTAINETTE SPECIFICATIONS

MODEL	P408	P608	P808	P2-2P4F	P2-4P2F	P400S	P800S	P100S	P30S
Use on Standard Model Ice Cream Cabinets	4DF, 6DF, 8DF, 10DF, 14DF	6DF, 10DF, 14DF	8DF, 10DF, 14DF	All Models	All Models	4DF, 6DF, 8DF, 10DF, 14DF	8DF, 10DF, 14DF	Free Standing	Free Standing
COMPONENTS									
Chocolate Pump & Jar	1	1	1	1	1	1	1	1	—
Regular Syrup Pump & Jar	1	2	2	1	3	1	2	1	—
Fruit Jar w/ cover & attached stainless steel ladle	2	3	6	4	2	2	6	2	3
Lids	1	1	2	—	—	—	—	—	—
Type	Sliding	Sliding	Sliding	—	—	—	—	—	—
Spoon Holder	1	1	1	—	—	—	—	—	—
DIMENSIONS (inches)									
Overall	24 x 25 1/2	35 1/2 x 25 3/4	48 x 25 3/4	12 1/2 x 25 1/2	12 1/2 x 25 1/2	24 1/2 x 11 1/2	47 3/4 x 11 1/2	19 1/2 x 9 1/2	15 x 9 1/2
Height of Back	9 1/2	9 1/2	9 1/2	9 1/2	9 1/2	7 1/2	7 1/2	7 1/2	7 1/2
Height to top of Chocolate Pump	13 3/4	13 3/4	13 3/4	15 1/2	15 1/2	12 1/2	12 1/2	13 1/2	13 1/2
SHIPPING WEIGHT (LBS.)	36	55	75	31	31	28	50	26	18
CUSTOM FOUNTAINETTES AVAILABLE Send Specification for Quotation									

WESTERN PIONEER SALES CO.

406 East Colorado Street Glendale, California 91205

(213) 245-7281