



HFF

Heavy Duty Storage Freezer

KEY ASPECTS

SPECIAL FEATURES:

- Interior/exterior shells made of heavy gauge high grade steel
- Efficient cold wall refrigeration system
- Environmentally friendly hydrocarbon refrigerant

OPTIONS:

- Graphics
- Locking bar
- Casters



Complies with 2017 DOE standards for commercial ice cream freezer with solid doors

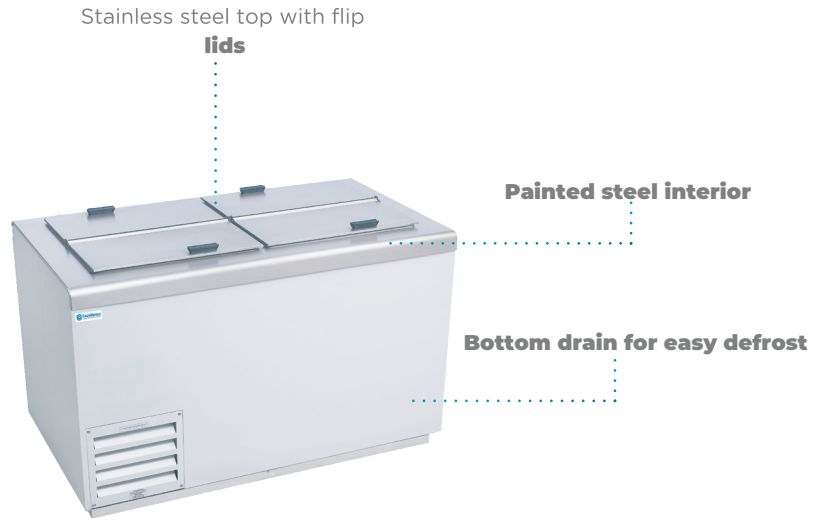

TECHNICAL SUMMARY

MODEL	SIZE Dimensions (inches) Width x Depth x Height	SIZE			ELECTRICAL			REFRIGERATION			OTHER	
		Cubic Feet	Net Weight (lbs.)	Shipping Weight (lbs.)**	Voltage/Hz/Phase	Running Amps	Max KWh/24hr	Compressor HP	Refrigerant	Temperature	3 Gallon can capacity/ Total Facings	Container Quantity
HFF-2HC	31 1/2 x 30 1/2 x 33 3/4	5.0	116	159	115/60/1	2.5	3.3	1/5	R-290	-14° to +6°F	4/3	110
HFF-4HC	30 3/4 x 30 1/2 x 33 3/4	7.9	168	194	115/60/1	3.3	3.1	1/5	R-290	-14° to +6°F	7/5	56
HFF-8HC	54 1/4 x 30 1/2 x 33 3/4	17.2	248	275	115/60/1	6.7	7.3	1/3	R-290	-14° to +6°F	21/12	44
HFF-12HC	80 3/4 x 30 1/2 x 33 3/4	27.6	350	357	115/60/1	6.8	7.3	1/3	R-290	-14° to +6°F	39/21	28

**Does not include weight of pallets when needed

