

# Blast & Shock 5

BLAST CHILLERS & SHOCK FREEZER



**Blast and shock quickly for a safe food!**

To preserve food products and to ensure its safety and quality.

Perfect for:



- gelato
- pastry & bakery
- catering



## ADVANTAGES AND STRENGTHS

- core temperature probe
- time chill or temperature chill
- automatic hot gas defrost
- self contained condensing unit
- reversible door
- preset gelato program
- electronic control
- 99 program capability
- HACCP memory with date, temperature and chilling cycles
- R404A refrigerant used

### Capacity

Trays 16" x 24" x 2,5"	5	1,3 Gallons Pans 6,5" x 14,2" x h 4,2"	6	Trays Pitch 2,7"
44 lbs		26,5 lbs		
194°F -> 37,4°F		194°F -> 0°F		



Control panel

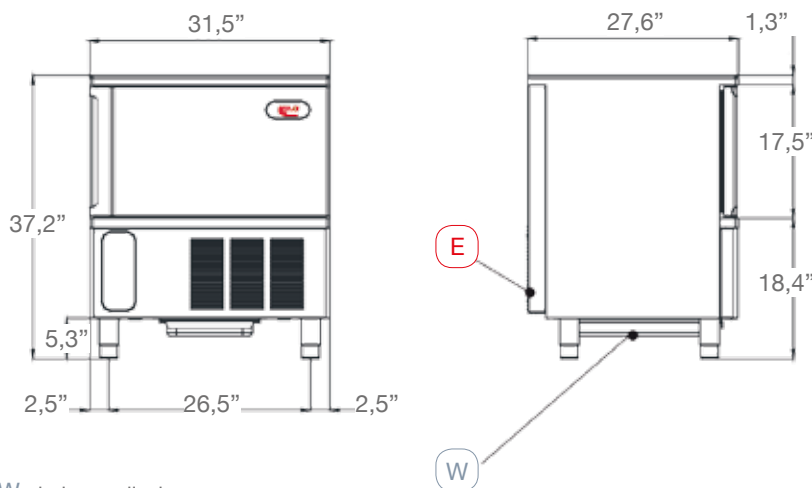

W drainage discharge

E electrical cable supply

### Technical features

Power supply	220-230V/1N/60Hz
Code number	BS 5
Outside length	31,5"
Height	37,2"
Depth	27,6"
Capacity 16"x24"x2,5"	5
Compressor	HERMETIC 1HP
Refrigeration power 14-113°F	1516 W
Refrigeration Fluid	1100 G - R404A
Output chilling (194-37,4°F)	44 lbs
Output freezing (194-0°F)	26,5 lbs
Electronic card	YES
Absorbed power	1050 W - 4,5 A
Weight net	238 lbs
Crate dimensions	29,9"x 34,3"x 42,5"
Crate weight	271 lbs



**Headquarter BRAVO SPA**  
Montecchio Maggiore - Vicenza, Italy  
Ph. 0039.0444.707.700

**BRAVO NORTH AMERICA INC.**  
810 Tyvola Road, Suite 130, Charlotte, NC 28217  
Ph.: (+1) 980 237 2474

info@bravo.it  
bravo.it

info@bravonorthamerica.com  
bravonorthamerica.com