



ZR432-2P

ZR400 Series Wireless Combination Smoke and Heat Detector (POLAR

General

The ZR432-2P is a wireless, POLAR WHITE addressable multisensor capable of operating in optical, temperature or multisensor, optical/heat modes.

Fast response to a wide range of fires

Designed to provide the earliest response to a wide range of fire types in locations where hard wiring is not an option, ZR432-2 detectors combine optical smoke sensing and thermal monitoring to provide an accurate warning of fire. Smoke sensing may be isolated for areas where ambient smoke may exist at certain times of the day, or used on a day night basis in premises where heat only is required whilst the building is occupied.

Detector control

The ZR432-2 detector is controlled from the main control panel via a loop wired radio interface module allowing both wireless and hardwired devices to be seamlessly located and controlled from the same wiring loop. Every wireless device controlled through the radio loop module, is assigned its own IDENT address with which the main control panel communicates, providing the same system facilities as directly wired devices.

System operation

Temperature and smoke sensitivity may be set by a selection of switches located in the base of the ZR432-2. Calibration and self-testing are carried out automatically.

Removal or replacement of an incorrect sensing devices are identified by the system and details displayed at the main control panel. Sophisticated auto contamination adjustment compensates for any long-term drift in performance caused by dirt entering the sensing chamber.

For ease of removal, ZR432-2 detectors plug into the radio base by a simple twist and lock action.

Certification

The ZR432-2 temperature response meets the requirements of European Standard EN54 Part 5 (settable to class A or class B), with smoke sensitivity complying with EN54 Part 7. The ZR432-2 is approved to EN54:5, EN54:7 and EN54:25, and carries CPD certification.



Standard Features

- No external aerials
- Dual battery supply
- Full device status monitoring – power sources, head removal and device tamper
- Senses both smoke and heat

ZR432-2P

ZR400 Series Wireless Combination Smoke and Heat Detector (POLAR)

Specifications

Model No.	ZR432-2P
Specification	EN54:5/7/25
Description	Radio Multisensor (Optical/Heat)
Approval	CPD Certified
Operating frequency	868 MHz
Compatibility	All ZP addressable systems via RLM
Mounting	Surface mount
Area coverage*	Smoke element - <100m ² Heat element - < 50m ²
Monitoring	Continuously self-checking
Detection principle	Smoke element - Photoelectric light scatter Heat element - Thermistor
Addressing method	Unique address embedded
Indication	Red alarm LED
Operating voltage	3 VDC
Power supply	Batteries in base
Application	Indoors
IP rating	IP32
Temperature range	
Operating	-10°C to +60°C
Storage	-20°C to +70°C
Humidity range (noncondensing)	10% to 95% RH
Material	Moulded ABS
Dimensions (dia x h)	106 mm x 75 mm (including base)
Colour	Polar White
Weight	350 g (including base & batteries)

* Subject to local regulations

Ordering Information

Part No.	Description
ZR432-2P	ZR400 Series Wireless Combination Smoke and Heat Detector (POLAR WHITE)

Comsec Protection Systems.

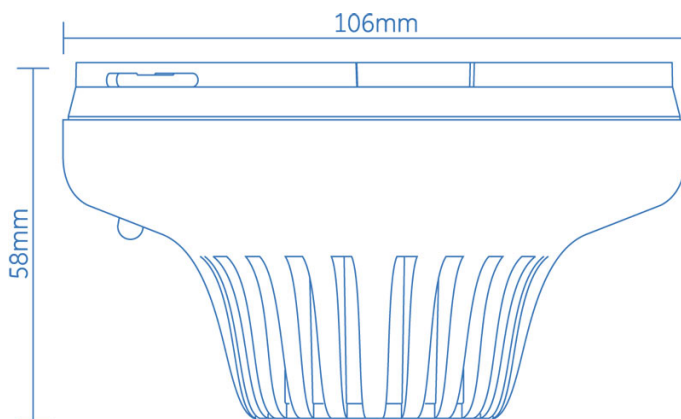

963-02

