

Orbis

I.S. Heat Detector



Technical data

All data is supplied subject to change without notice. Specifications are typical at 24 V, 23°C and 50% RH unless otherwise stated.

Detection principle	Measurement of heat by means of a thermistor.
Sampling frequency	Once every two seconds
Supply voltage	14 V dc to 28 V dc
Supply Wiring	Two wire supply, polarity sensitive
Polarity reversal	Not allowed
Power up time	< 20 seconds
Minimum 'detector active' voltage	12 V
Power-up surge current at 24 V	105 µA
Average quiescent current at 24 V	80 µA
Alarm load	325 Ω in series with a 1.0 V drop
Minimum holding voltage	5 V
Minimum voltage to light alarm LED	6 V
Alarm reset voltage	< 1 V
Alarm reset time	One second
Alarm indicator	Integral indicator with 360° visibility
Remote output LED (-) characteristic	4.7 kΩ connected to negative supply
Operating and storage temperature	-40°C to +70°C Operating temperature is restricted by the intrinsic safety gas classification. Class T5: -40°C to +45°C Class T4: -40°C to +60°C The detector must be protected from conditions of condensation or icing.
Humidity (no condensation or icing)	0% to 98% RH
Effect of atmospheric pressure on optical sensor	Insensitive to pressure
Effect of wind speed	Unaffected by wind
Designed to IP Rating	IP23D
Standards & approvals	EN54-5, CPD, LPCB, MED, LR, DNV-GL, BV, ABS, CCS, KRS, VdS, BOSEC, IECEX, ATEX, PESO, SBSC and FG
BASEEFA Certification	Bas06ATEX0007X
Dimensions	100 mm diameter x 42 mm height 100 mm diameter x 50 mm height in base
Weight	70 g detector 130 g detector with base
Materials	Housing: White flame-retardant polycarbonate Terminals: Nickel plated stainless steel

Product overview

Product	Orbis I.S. Heat Detector	Oris I.S. Heat Detector with flashing LED
	Part No.	Part No.
Class A1R	ORB-HT-51145-APO	ORB-HT-51146-APO
Class A1S	ORB-HT-51157-APO	ORB-HT-51158-APO
Class A2S	ORB-HT-51147-APO	ORB-HT-51148-APO
Class BR	ORB-HT-51149-APO	ORB-HT-51150-APO
Class BS	ORB-HT-51151-APO	ORB-HT-51152-APO
Class CR	ORB-HT-51153-APO	ORB-HT-51154-APO
Class CS	ORB-HT-51155-APO	ORB-HT-51156-APO

Approvals



Note: Not all detector variants have VdS or SBSC approval. This can be checked at www.apollo-fire.co.uk

Product information

The Orbis Intrinsically Safe (I.S.) Heat Detector range incorporates seven heat detector classes to suit a wide variety of operating conditions in which smoke detectors are unsuitable.

36 Brookside Road, Havant | Tel: +44 (0)23 9249 2412 | Email: sales@apollo-fire.com
Hampshire, PO9 1JR, UK. | Fax: +44 (0)23 9249 2754 | Web: www.apollo-fire.co.uk



A HALMA COMPANY

© Apollo Fire Detectors Limited 2017



The European Standard EN 54-5 classifies heat detectors to the highest ambient temperature in which they can safely be used without risk of false alarm.

The classes are identified by the letters A to G (Class 1 is subdivided into A1 and A2). In addition to the basic classification, detectors may be identified by a suffix to show that they are rate-of-rise (suffix R) or fixed (static) temperature (suffix S) types. All heat detectors in the Orbis I.S. range are tested as static or rate-of-rise detectors and are classified as A1R, A1S, A2S, BR, BS, CR and CS.

Operation

Orbis I.S. Heat Detectors have an open-web casing which enables air to flow freely across a thermistor which measures the air temperature every two seconds. A microprocessor stores the temperatures and compares them with pre-set values to determine whether a fixed upper limit - the alarm level - has been reached. In the case of rate-of-rise detectors the microprocessor uses algorithms to determine how fast the temperature is increasing.

Static heat detectors respond only when a fixed temperature has been reached. Rate-of-rise detectors also have a fixed upper limit but they also measure the rate of increase in temperature. A fire might thus be detected at an earlier stage than with a static detector so that a rate-of-rise detector is to be preferred to a static heat detector unless sharp increases of heat are part of the normal environment in the area protected by the heat detector

Where to use heat detectors

Heat detectors are used in applications where smoke detectors are unsuitable. Smoke detectors are used whenever possible since smoke detection provides earlier warning of fire than heat detection.

Heat detectors should be used if there is a danger of nuisance alarms from smoke detectors.

Choosing the correct class of heat detector

Heat detectors have a wide range of response characteristics and the choice of the right type for a particular application may not always seem straightforward. It is helpful to understand the way that heat detectors are classified as explained earlier and to memorise a simple rule: use the most sensitive heat detector available consistent with avoiding false alarms.

In the case of heat detectors it may be necessary to take an heuristic approach, i.e., trial and error, until the best solution for a particular site has been found. The flowchart will help in choosing the right class of heat detector.

If the fire detection system is being designed to comply with BS 5839-1 heat detectors should be installed at heights of less than 12 metres with the exception of Class A1 detectors, which can be installed at heights of up to 13.5 metres.

EMC Directive 2014/30/EU

The Orbis I.S. Heat Detector complies with the essential requirements of the EMC Directive 2014/30/EU, provided that it is used as described in this datasheet.

A copy of the Declaration of Conformity is available from the Apollo website: www.apollo-fire.co.uk

Conformity of the Orbis I.S. Heat Detector with the EMC Directive, does not confer compliance with the directive on any apparatus or systems connected to them

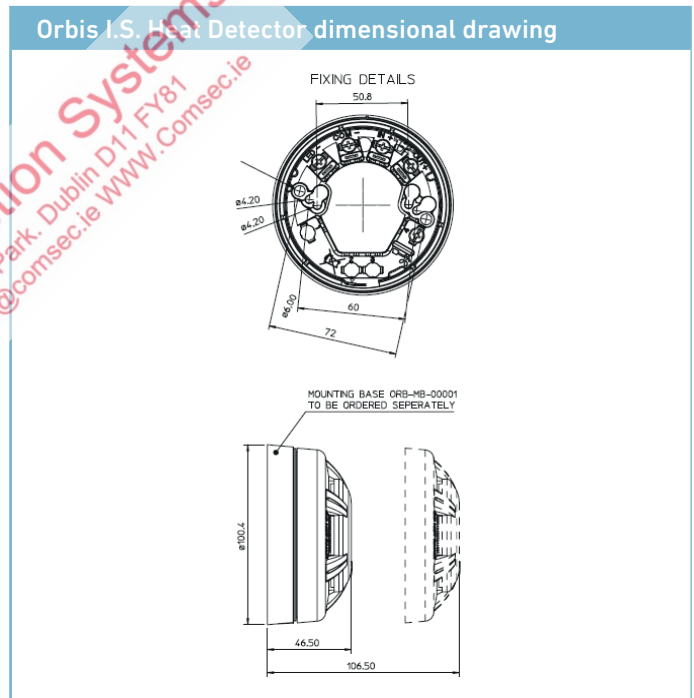
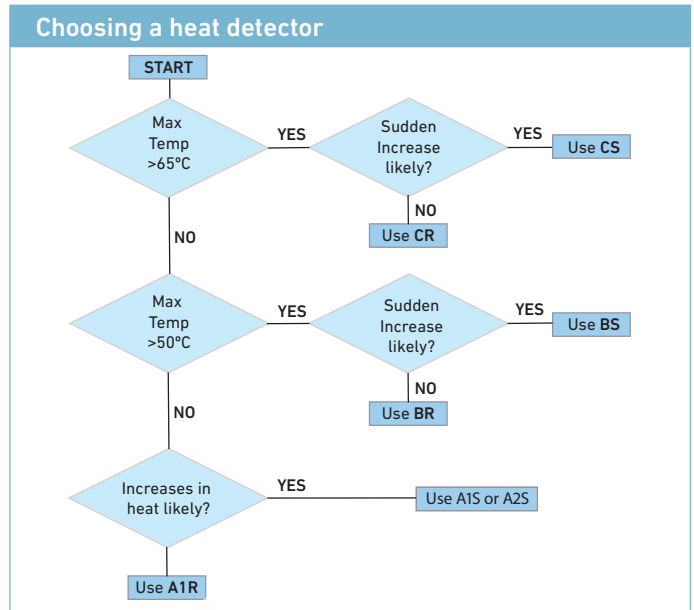

Construction Products Regulation 305/2011/EU

The Orbis I.S. Heat Detector complies with the essential requirements of the Construction Products Regulation 305/2011/ EU.

A copy of the Declaration of Performance is available from the Apollo website: www.apollo-fire.co.uk

Marine Equipment Directive 2014/90/EU

The Orbis I.S. Heat Detector complies with the essential requirements of the Marine Equipment Directive 2014/90/EU.

ATEX Directive 2014/34/EU

The Orbis I.S. Heat Detector complies with the essential requirements of the ATEX Directive 2014/34/EU.

Orbis detectors: LED status

Feature	Description	Red LED status	Yellow LED status
StartUp™	Confirms that the detectors are wired in the correct polarity	Flashes once per second	No Flash
FasTest™	Maintenance procedure, takes just four seconds to functionally test and confirm detectors are functioning correctly	Flashes once per second	No flash
DirtAlert™	Shows that the drift compensation limit has been reached	No flash	Flashes once per second in StartUp (Stops flashing when StartUp finishes)
SensAlert™	Indicates that the sensor is not operating correctly	No flash	Flashes every four seconds (Flashes once per second in StartUp)
Normal operation	At the end of StartUp and FasTest (without flashing LED as standard)	No flash	No flash
Flashing LED version	Detectors red LED flashes in normal operation (at the end of FasTest)	Flashes every four seconds	No flash

Comsec Protection Systems.
 26 Stadium Business Park, Dublin D11 FY81
 Tel +353 1 8853008 Email info@comsec.ie WWW.Comsec.ie

This page has intentionally been left blank

Comsec Protection Systems.
26 Stadium Business Park, Dublin D11 FY81
Tel +353 1 8853008 Email info@comsec.ie www.comsec.ie