



XP95 Sounder VAD Base

FUNCTION

The XP95[®] Sounder Visual Alarm Device (VAD) Bases incorporates a standard mounting base with a loop-powered sounder VAD. It is used to signal a fire alarm in enclosed areas.

The XP95 Sounder VAD Base can be used either with a detector fitted or with a cap for operation as a stand-alone alarm device. The XP95 Sounder VAD Bases are supplied with a built-in isolator.

FEATURES

The product offers:

- Two volume ranges 55–75dB(A) and 75–91dB(A)
- EN54-23 Compliant Category O. VAD
- EN54-3 Compliant Sounder
- VAD flash rate of 0.5Hz
- Synchronisation of 'alert' and 'evacuate' tones
- Individual and group addressing
- Unique acoustic self-test
- Unique VAD self-test
- Built in Isolator
- Complies with NEN2575 (45681-706), DIN0833 and DIN33404 (45681-707)



Part no 45681-705 - XP95 Sounder VAD Base with Isolator



INVESTOR IN PEOPLE

A HALMA COMPANY



Assessed to ISO 9001:2008
LPCB Cert No. 010



Certificate No. 010
See www.RedBookLive.com



Assessed to ISO 14001:2004
Certificate number EMS 010

© Apollo Fire Detectors Limited 2016

36 Brookside Road, Havant,
Hampshire, PO9 1JR, UK.

Tel: +44 (0)23 9249 2412
Fax: +44 (0)23 9249 2754

Overseas offices: America China Germany



0832

Email: sales@apollo-fire.com
Web: www.apollo-fire.co.uk

The low volume range is useful in areas such as hospitals where a fire alert is initially intended to warn staff only. The sounder is set to the high range for general use.

Synchronisation of tones ensures the integrity of the signal—tones from different sounders do not merge into one signal that could be mistaken for a different tone.

Group addressing is a simple method of alerting an entire area or group of rooms without delay.

For systems requiring isolators at every point the built-in isolator saves installation time and cost.

The acoustic self-test means that the sounder listens to itself when it is switched on. If no sound is detected a fault signal is transmitted when the sounder is polled.

The VAD self test is achieved by means of an LED monitoring circuit. If the LEDs do not draw current when the Sounder VAD Base has been switched on a fault signal is transmitted when the device is next polled.

ELECTRICAL CONSIDERATIONS

The Sounder VAD Base is loop-powered so needs no external power supply. It operates at 17–28V DC and is polarity-sensitive.

tone frequency and volume control

The tone frequency of the sounders, together with sound pressure levels, is published in a separate document, PP2203 available from Apollo.

ADDRESSING

The XP95 Sounder VAD Base responds to its own individual address set with a DIL switch. It also responds both to a group address, set by means of a 4-segment DIL switch and to a synchronisation address which is embedded in the unit.

Addresses 1 to 111 are used exclusively for individual addresses; addresses 112 to 126 are used for group addressing. Any Sounder VAD Bases on a loop may be freely assigned to a group. The address for any group *must* be chosen from the range 112–126.

Addresses 112–126 *may* be used as individual addresses but *only* if the 4-segment DIL switch

is not used ie, group addressing is disabled. If the 4-segment DIL switch were set to any number other than the default 127, a pre-set analogue value of 4 would be transmitted to indicate a fault.

The XP95 Sounder VAD Bases are normally polled by the individual address. If more than one Sounder VAD Base is activated it is possible for the sounders to be synchronised with each other.

GROUP ADDRESSING

It may be desirable, in alarm conditions, to switch more than one Sounder VAD Base simultaneously. To enable this, devices may be controlled as a group and given a group address which is common to all Sounder VAD Bases in the group. When a device recognises its group address, it will process the output bits but it will not return any data to the control panel on that address. If it is required to confirm the status of the outputs of devices under group address control it is necessary to interrogate all devices in the group at their individual addresses.

SELF TEST

An important safety feature has been incorporated into the Sounder VAD Bases: when it is switched on it tests itself by checking the actual sound output and flash operation. If no sound is detected within 5 seconds of the Sounder VAD Bases being switched on it will transmit an analogue value of 1 (= sounder fault) when it is next polled. If no current is drawn by the LEDs an analogue value of 2 (= VAD fault) is transmitted. If neither element is operating an analogue value of 3 (= Sounder and VAD fault) is transmitted on the next polling.

This feature can also be used during commissioning or periodical maintenance testing. Simply activate the Sounder VAD for at least 5 seconds and check the control panel for a fault signal. If none is received, the Sounder VAD Base is working properly.

PROTOCOL COMPATIBILITY

The Sounder VAD Bases will operate only with compatible control equipment using the Apollo XP95 or Discovery protocol. The features of the Sounder VAD Base are available only when it is connected to a control panel with the appropriate software.

SYNCHRONISATION

It is possible to synchronise the sound and flash outputs of all Sounder VAD Bases connected to a loop. Other alarm devices, including the 100dB Sounder, the Integrated Base Sounder, the Intelligent Base Sounder, the Sounder Control Unit and the loop-powered VAD, may also be synchronised.

This method of synchronisation depends on the design and configuration of the control panel. Further information should be sought from the manufacturer of the panel.

MECHANICAL CONSTRUCTION

The Sounder VAD Base is moulded in polycarbonate and has stainless steel contacts that accept solid or stranded cables of up to 2.5mm².

PROTOCOL USAGE

Output Bits	
2	Group Mode
1	Alert Tone
0	Evacuate Tone
Interrupt	No
Analogue Value	
Quiescent	16
Group Address	4
Conflict	
SNDR and VAD Fail	3
VAD Fail	2
Sounder Fail	1
Input Bits	
2	Group Mode Confirmed
1	Alert Confirmed
0	Evacuate Confirmed
Flag Setting	
XP95 Flag	Yes
Alarm Flag	No

TECHNICAL DATA

Operating voltage	17–28V DC
Protocol pulses	5-9V
Current consumption at 24VDC	
Quiescent	350µA
Switch-on surge	1.2mA for 1 sec
Activated	14mA
VAD frequency	0.5Hz
IP rating	IP21C
Sounder Output (45681-705/706)	
High tone setting volume - nominally 75dB (A) to 91dB (A) (Complies with EN54-3)	
Low tone setting volume - nominally 55dB(A) to 75dB(A)	
Sounder Output (45681-707)	
High tone setting volume - nominally 65 to 85dB (A) (Complies with EN54-3)	
Low tone setting volume - nominally 50 to 65dB(A)	

DIMENSIONS AND WEIGHT

Part no	Description	Dimension & Weight
45681-705	XP95 Sounder VAD Base with Isolator (white flash)	115 x 38mm 168g
45681-706	XP95 Slow whoop Sounder VAD Base with Isolator (white flash)	
45681-707	XP95 Sounder VAD Base DIN with Isolator (white flash)	
45681-292	White Cap	100 x 9mm 20g
45681-293	Red Cap	

Notes

1. The Sounder VAD Base is certified to EN54-3 when it is used in the higher volume range.
2. The lower volume range does not comply with EN54-3 and should not be used as part of an alarm application.

The purpose of the lower volume range is to provide a warning in specific cases such as hospital staff stations.

3. The Sounder VAD Base is a Type A device, ie, for indoor use only.
4. The isolating circuit of the Sounder VAD Bases is certified to EN54-17.
5. For information on isolating circuits see publication PP2090 available on request from Apollo.

DIMENSIONAL DRAWING

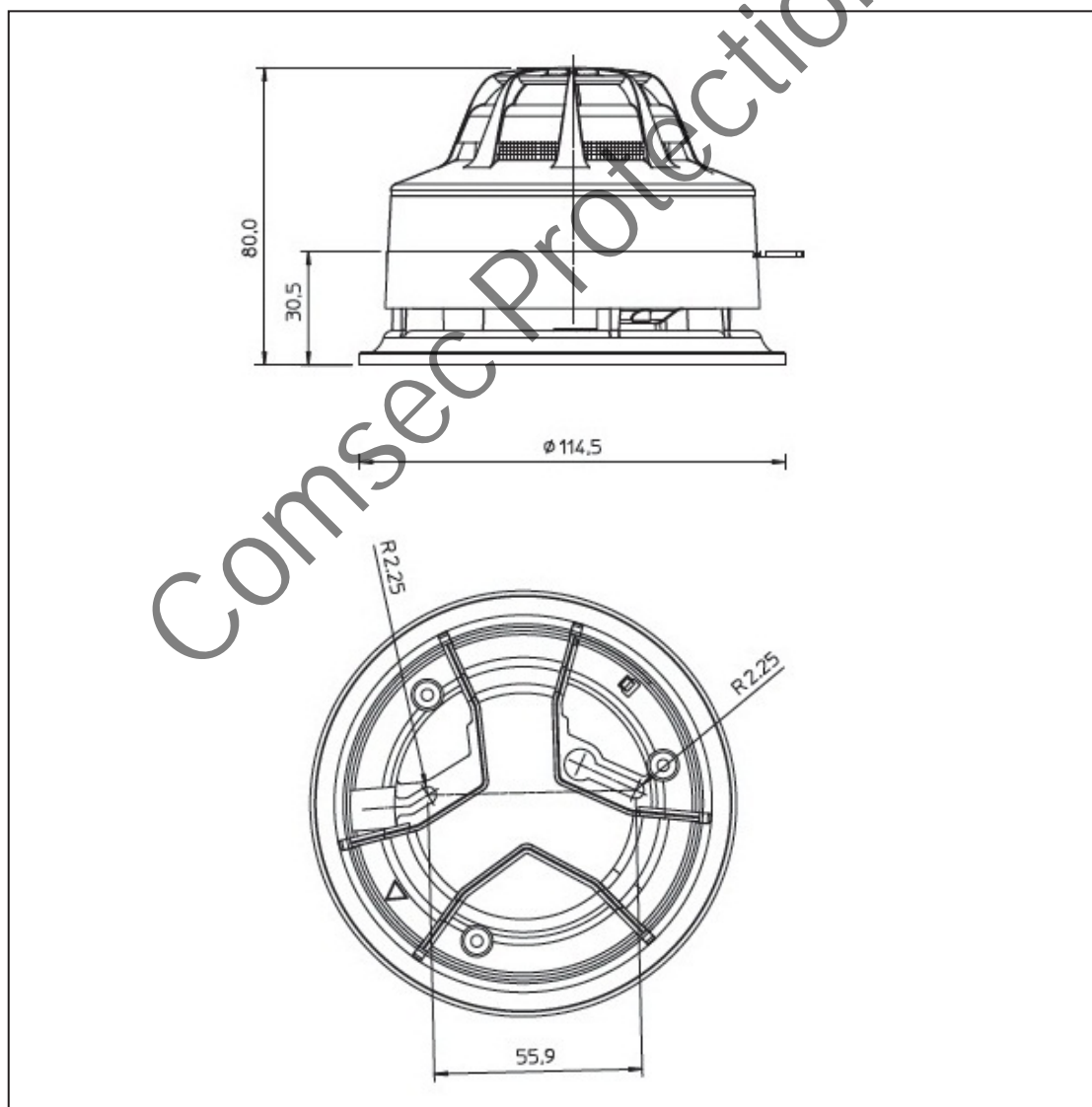

COVERAGE DIAGRAM

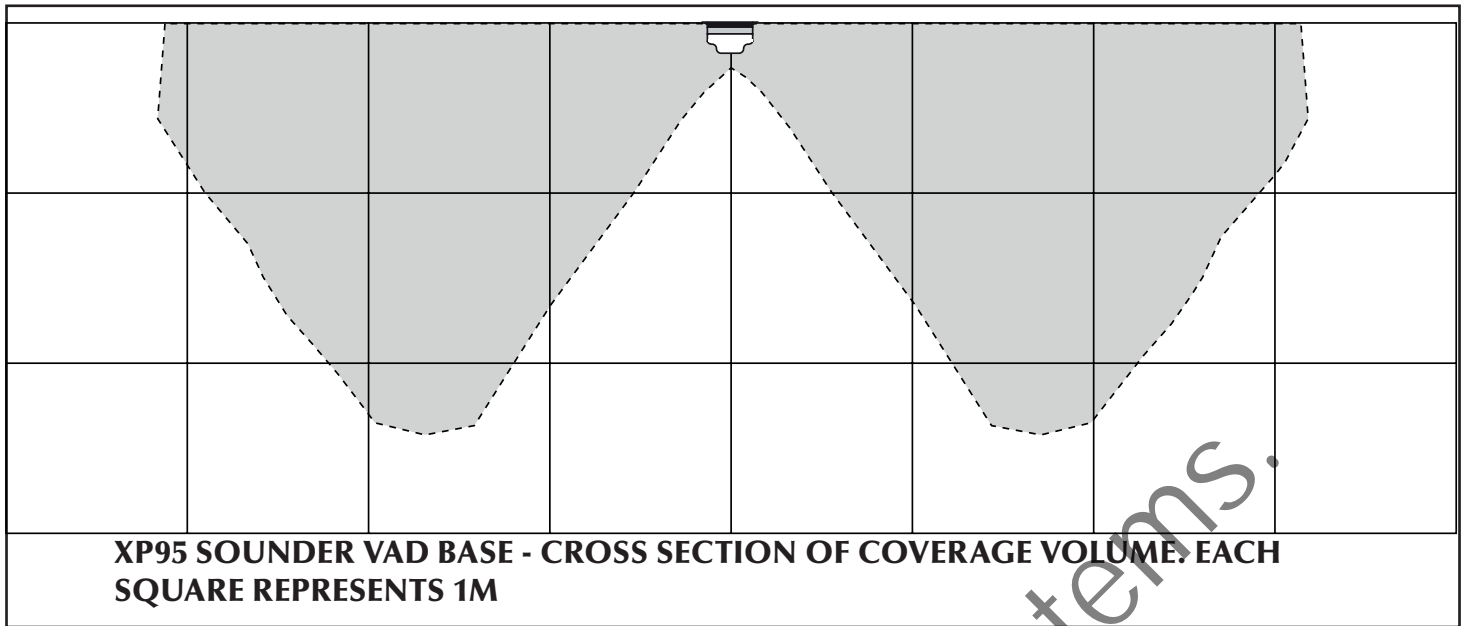

Comsec Protection Systems.