

3.

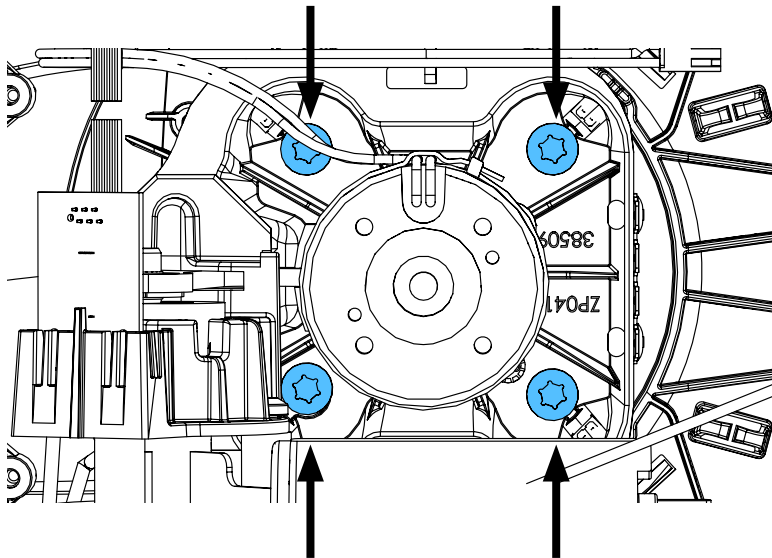

4.

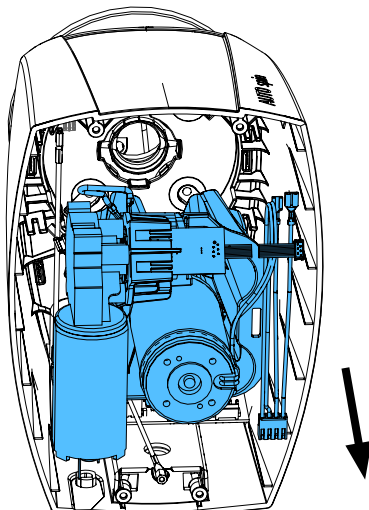

5.

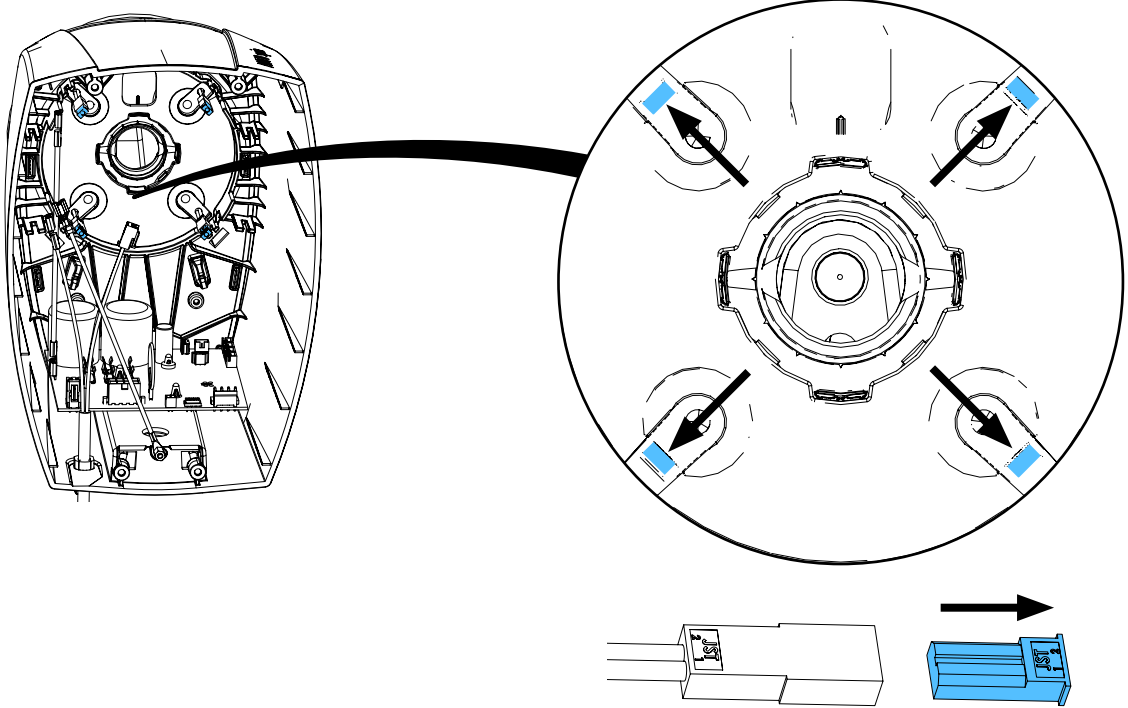

6.

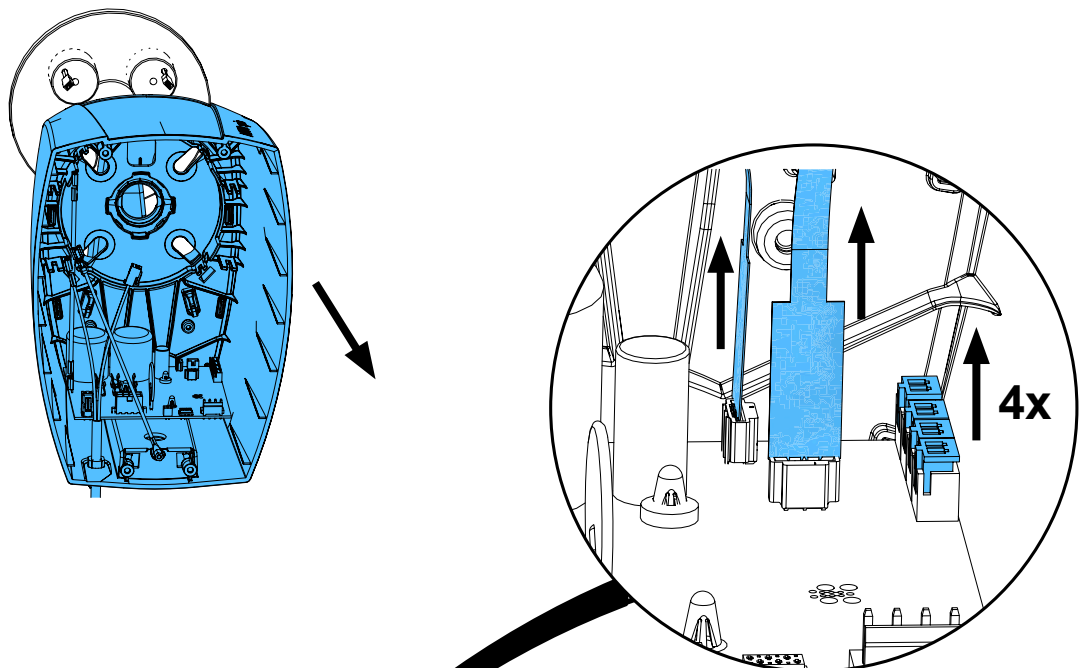

7.

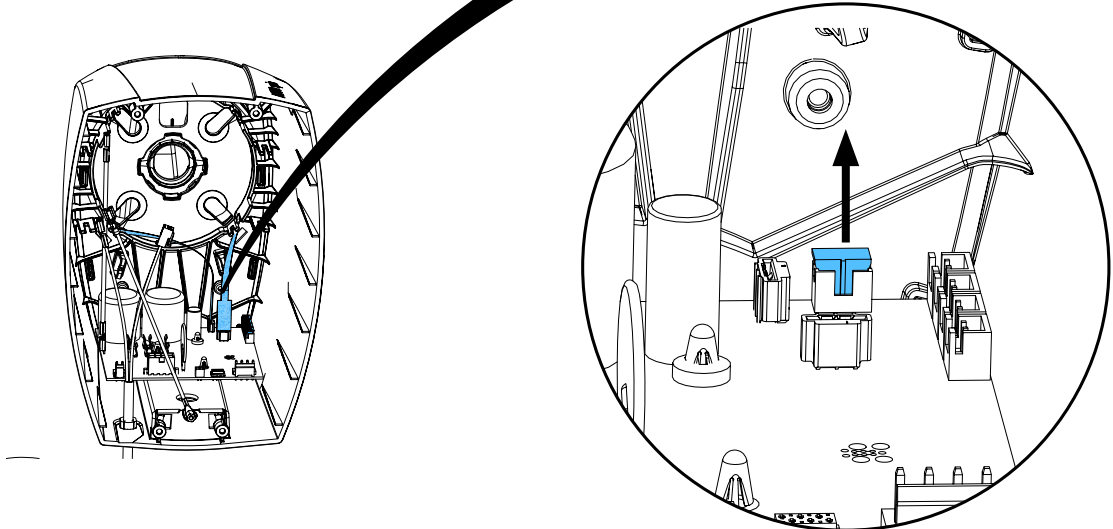

8.

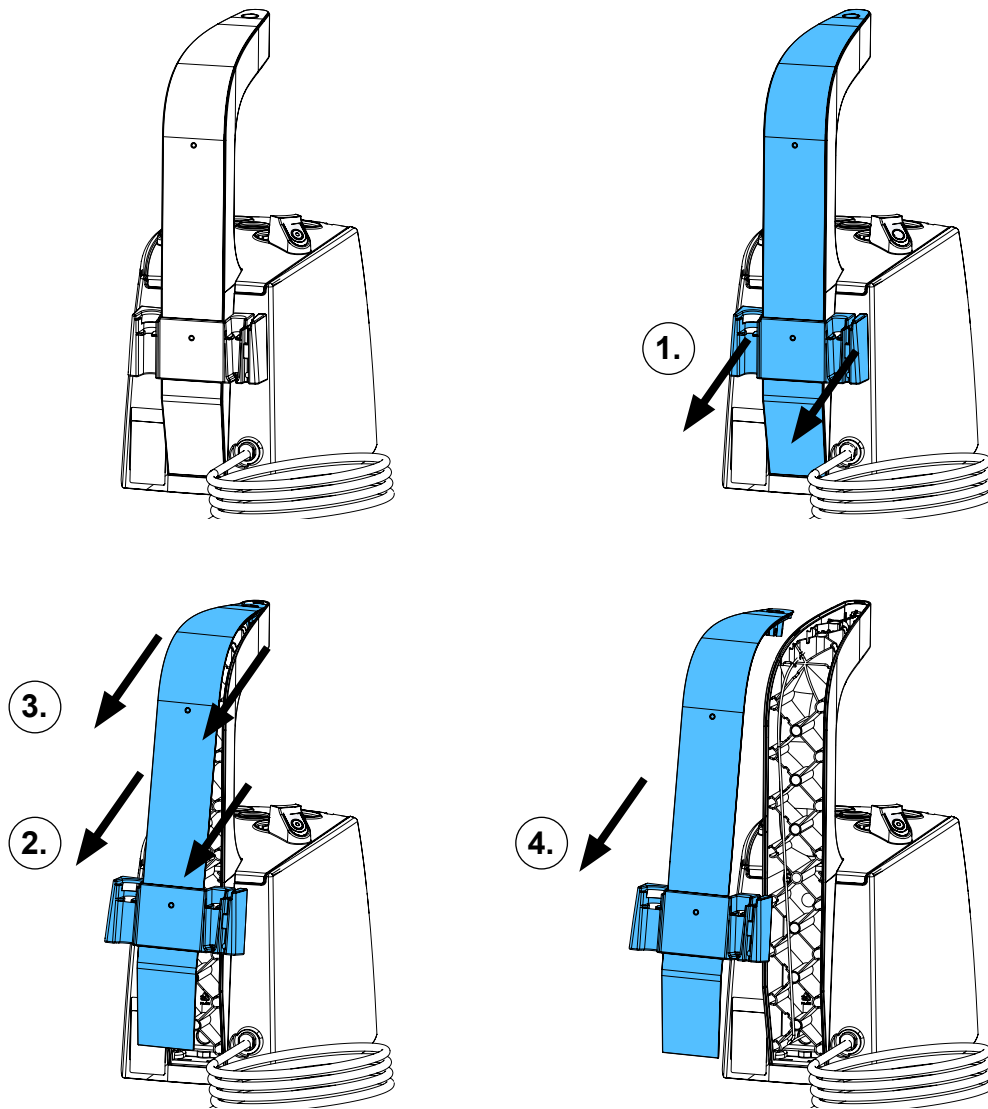

9.

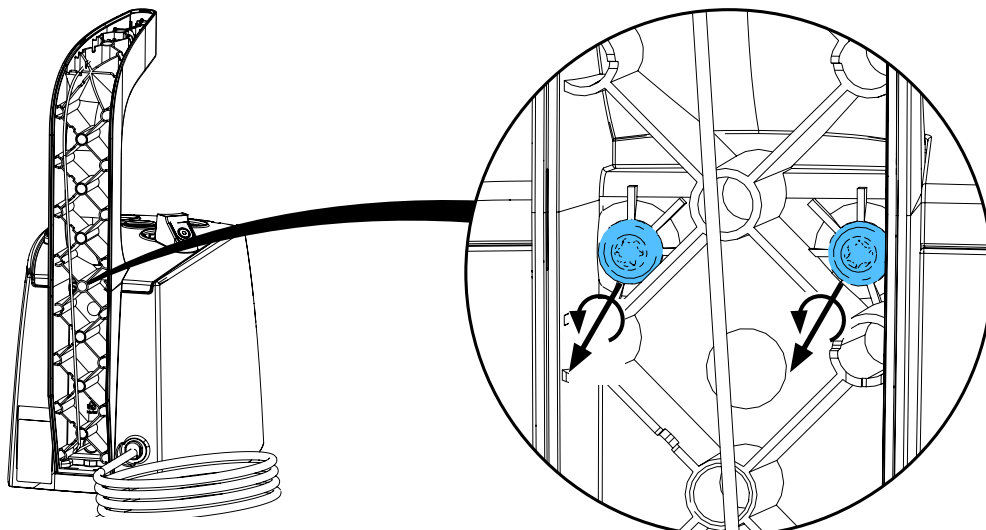

10.

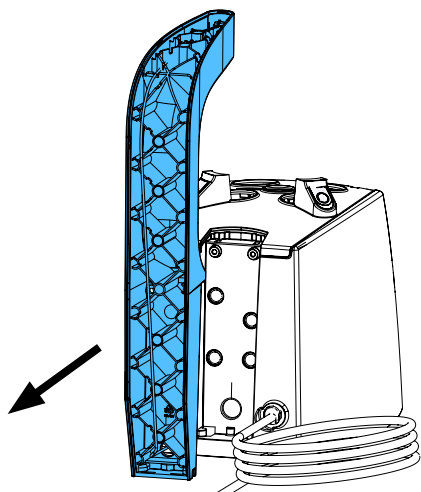

11.

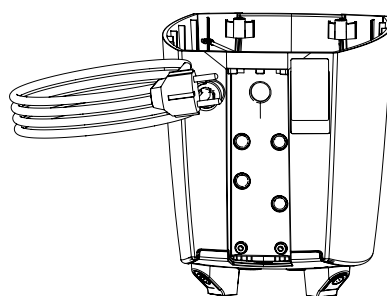
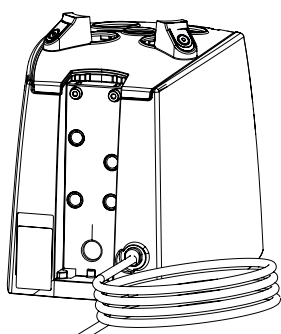

12.

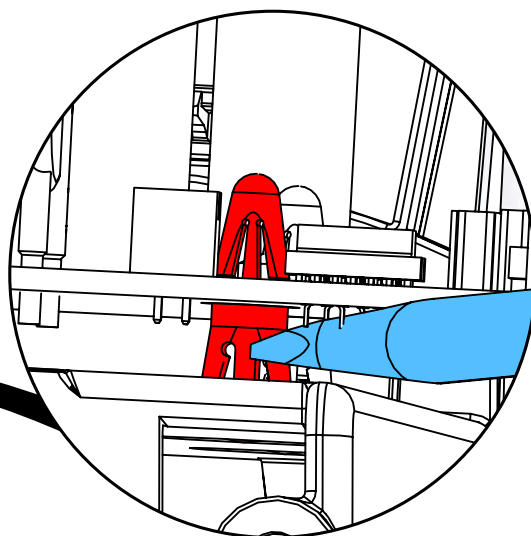
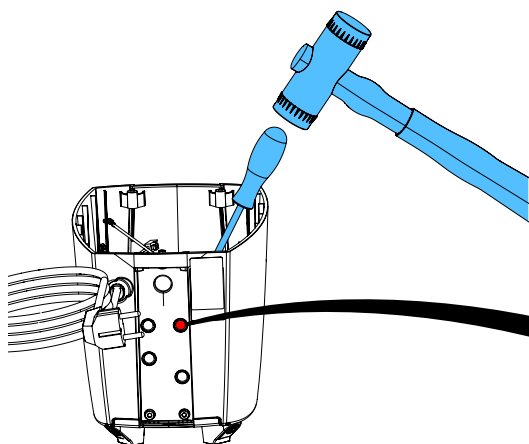

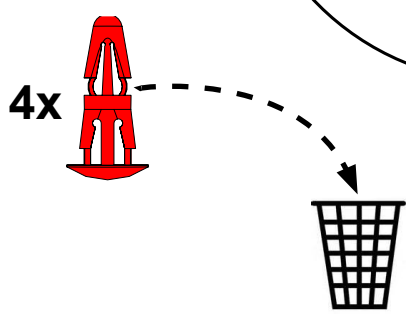
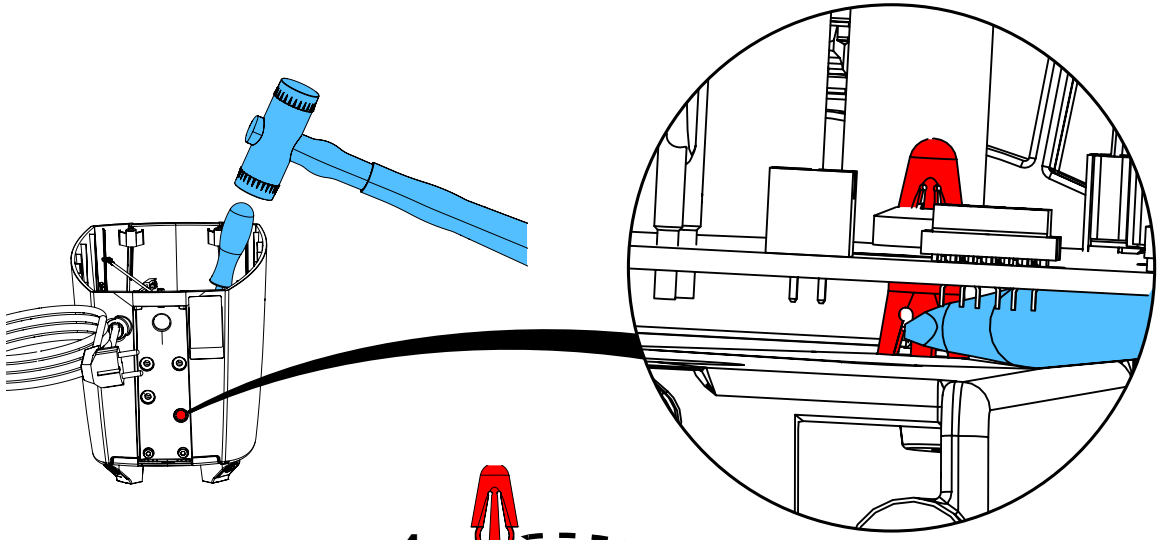
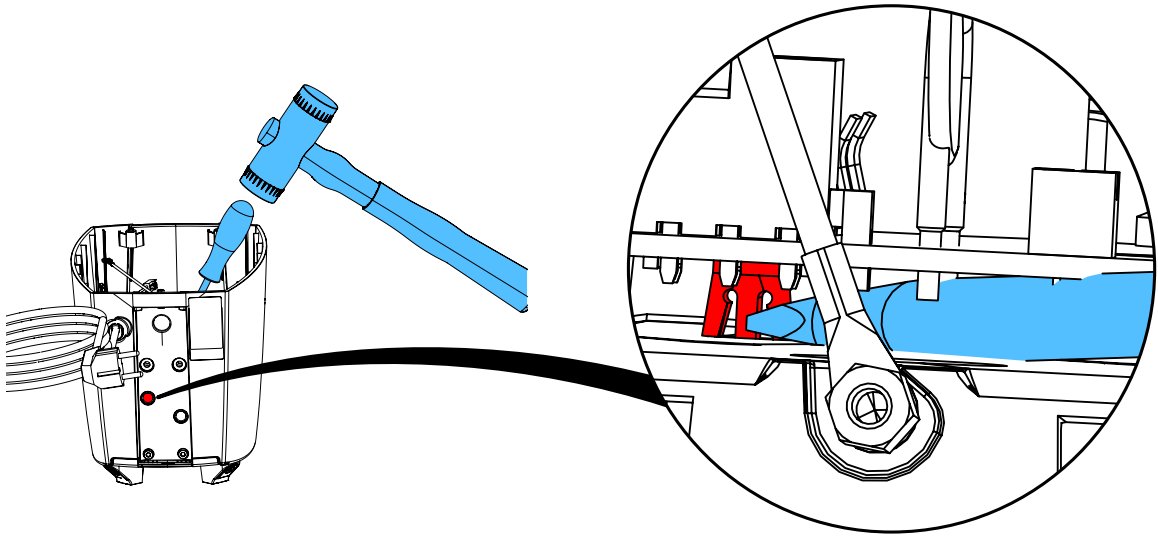
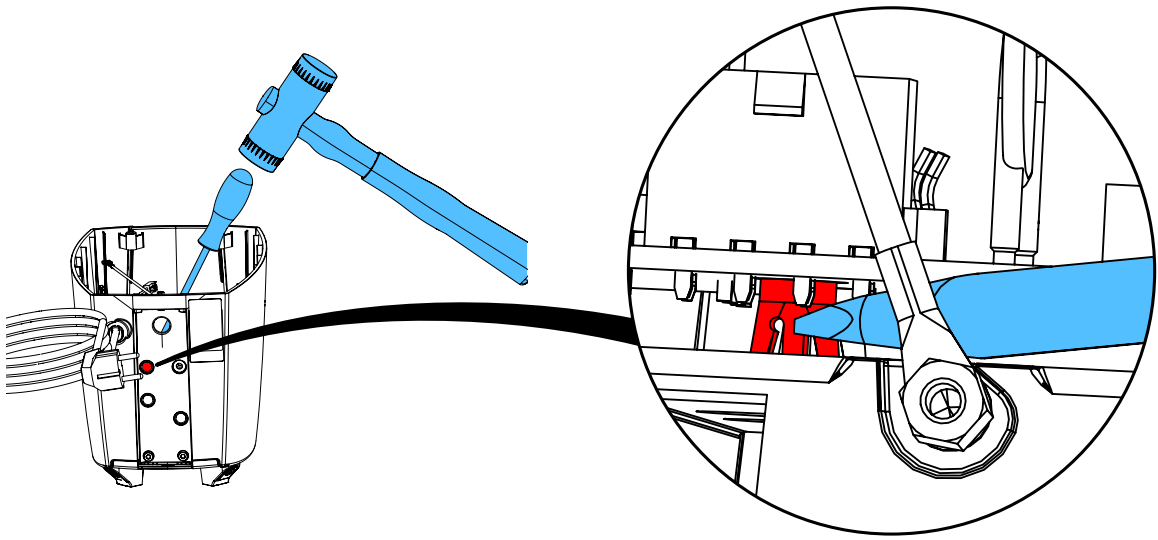

13.

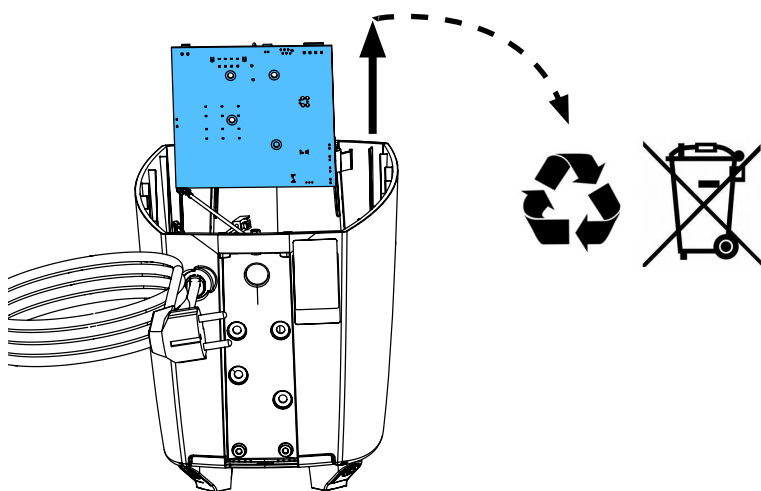

14.

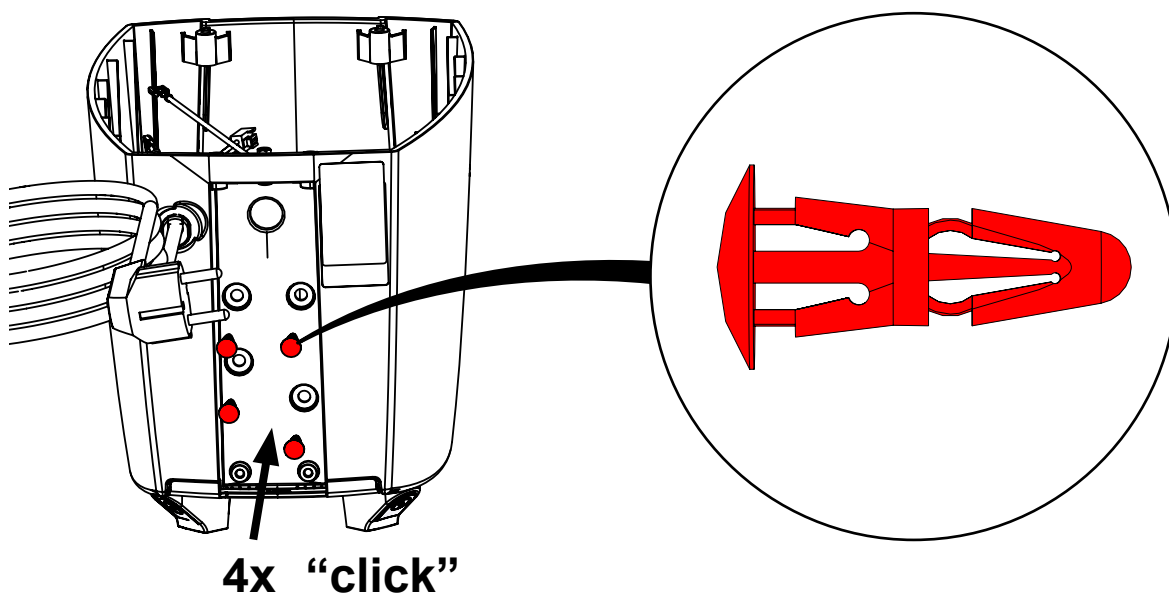

15.

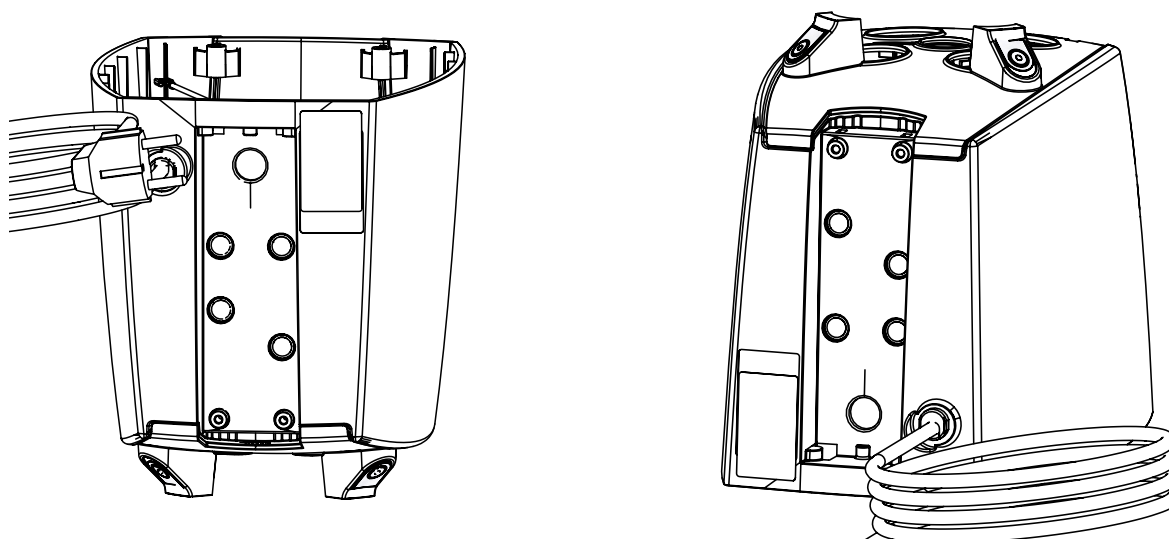

16.

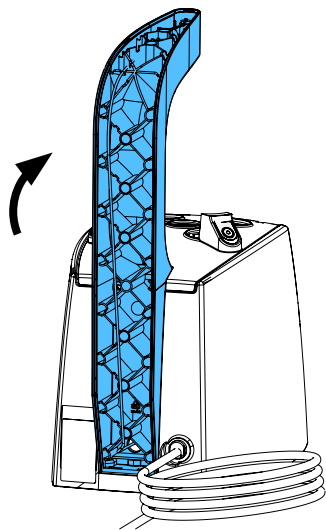
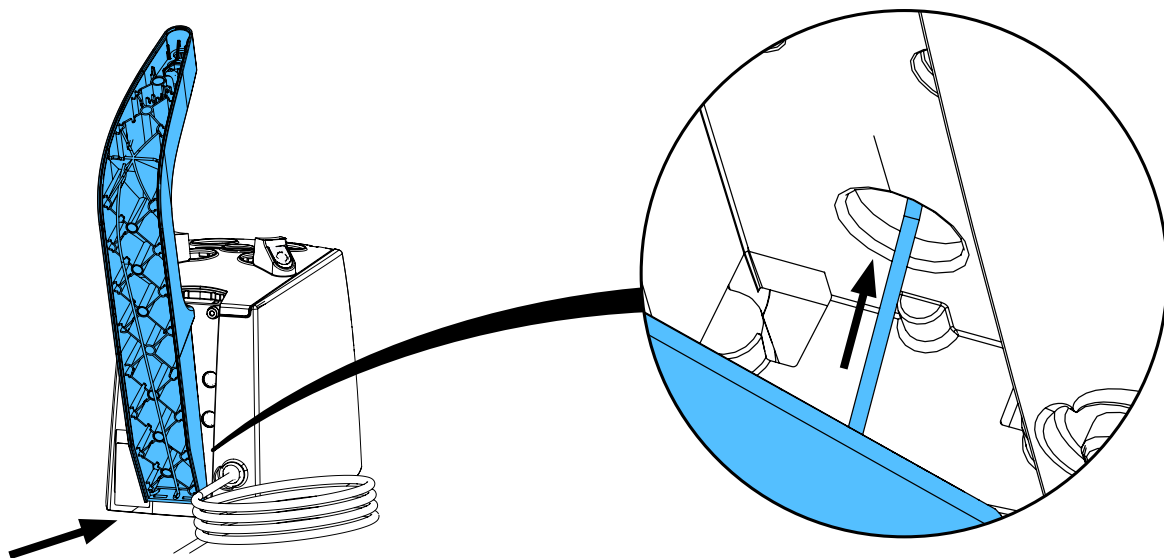

17.

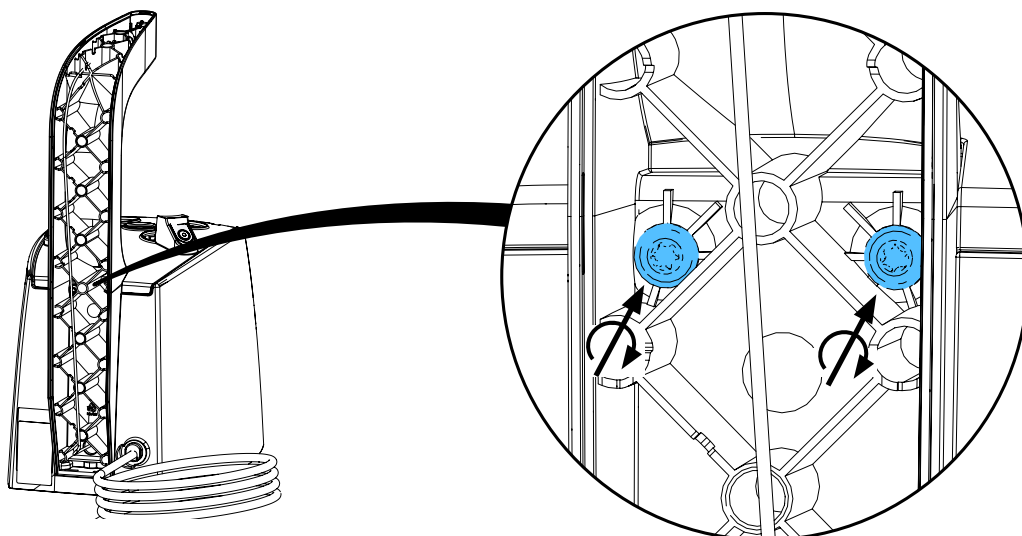

1,2 - 1,4 Nm

18.

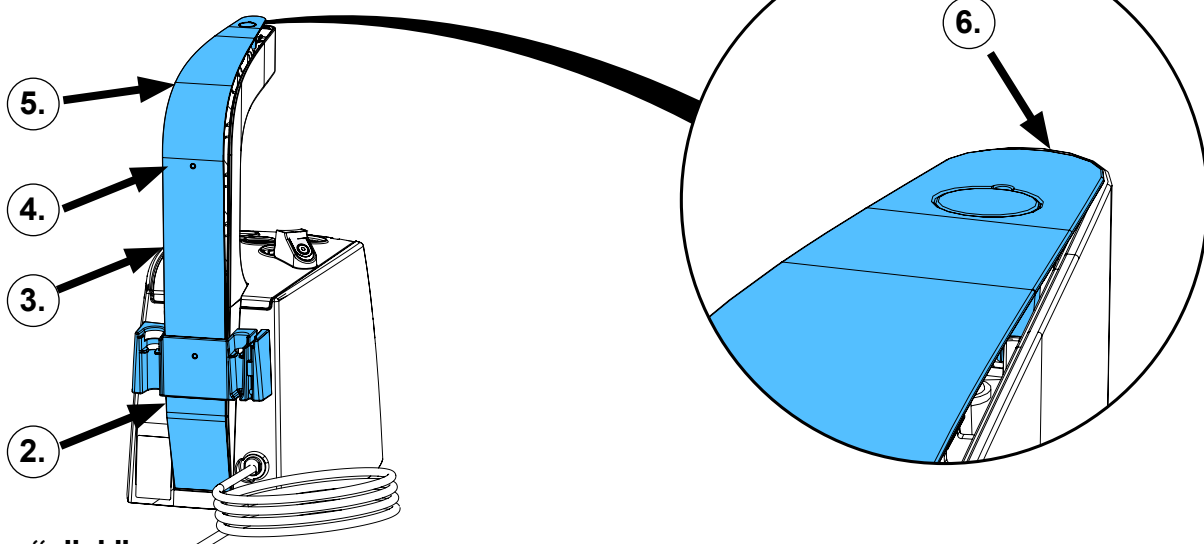
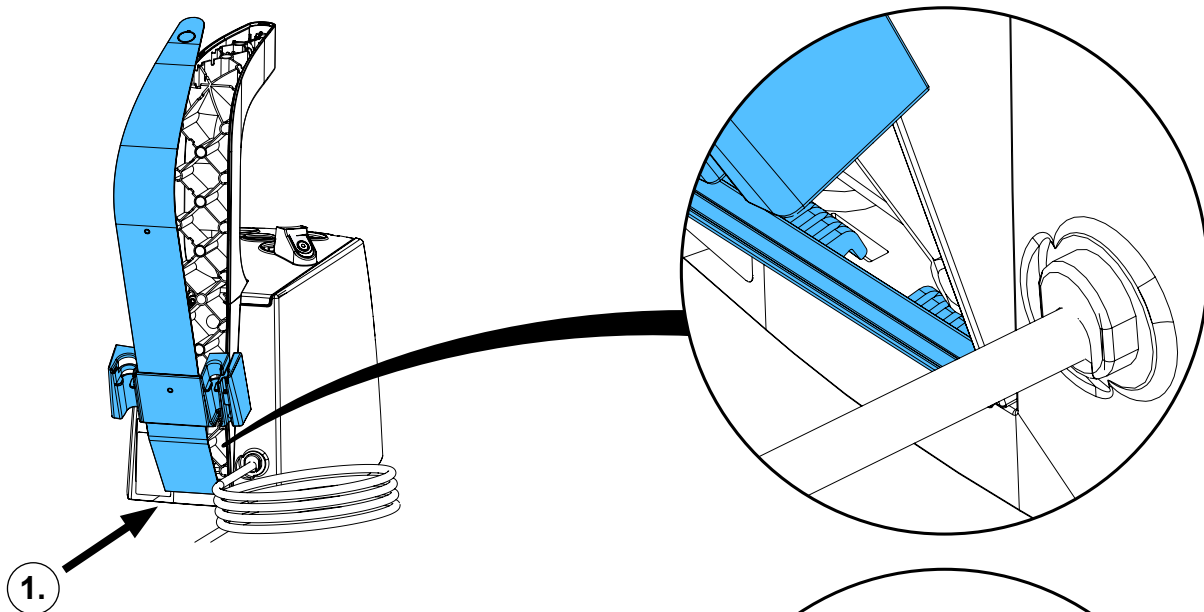

“click”

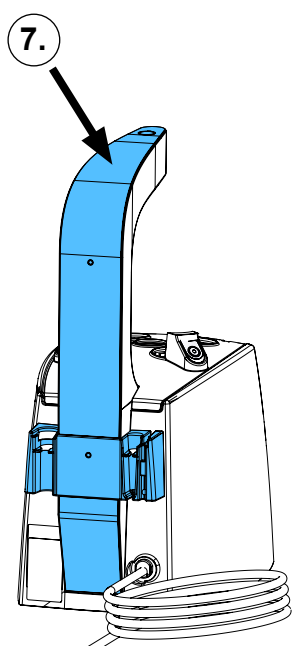

19.

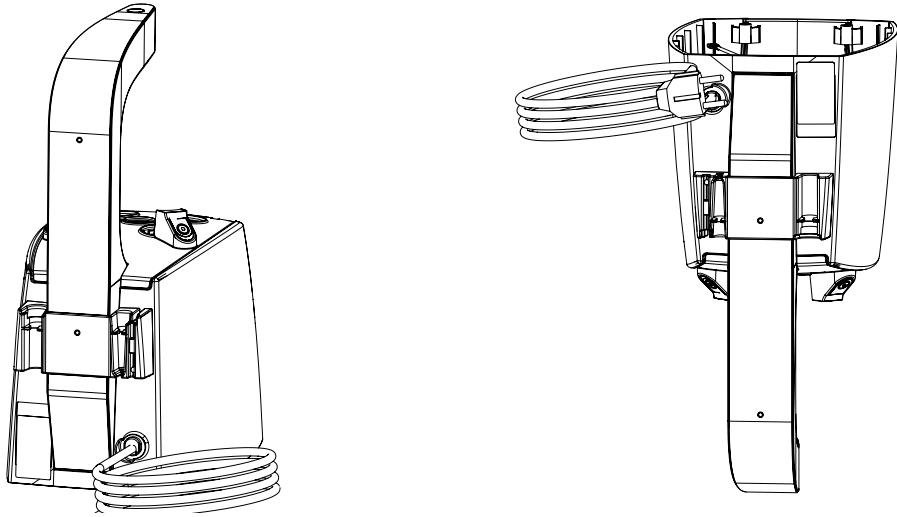

ESD

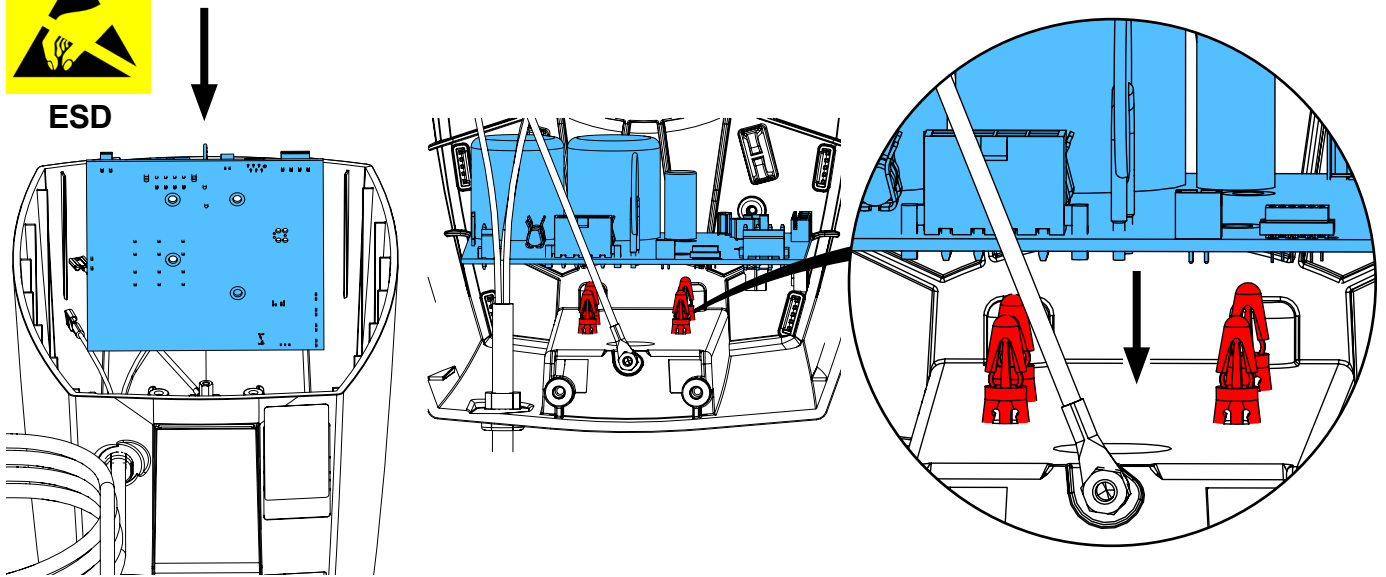

20.

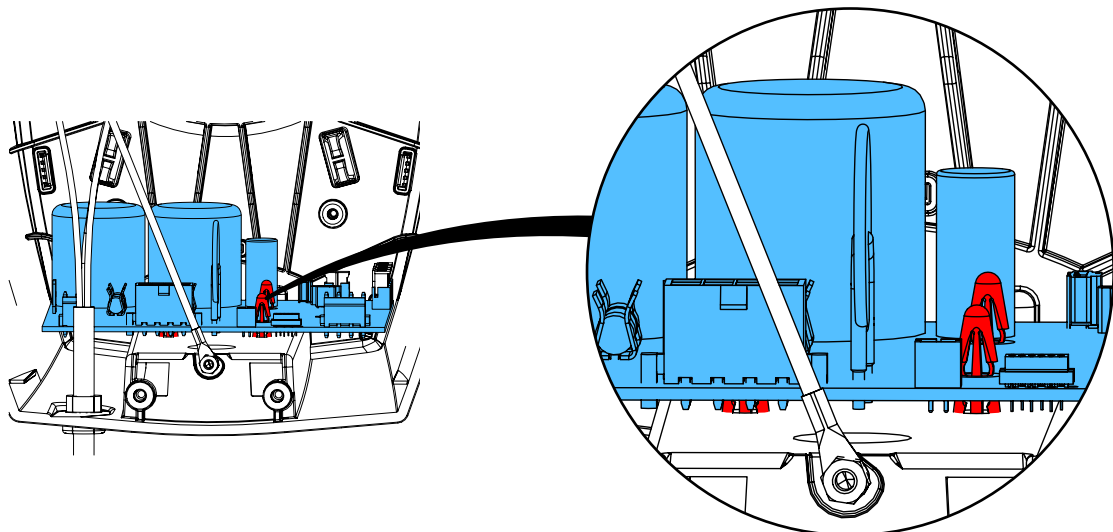

4x "click"

21.

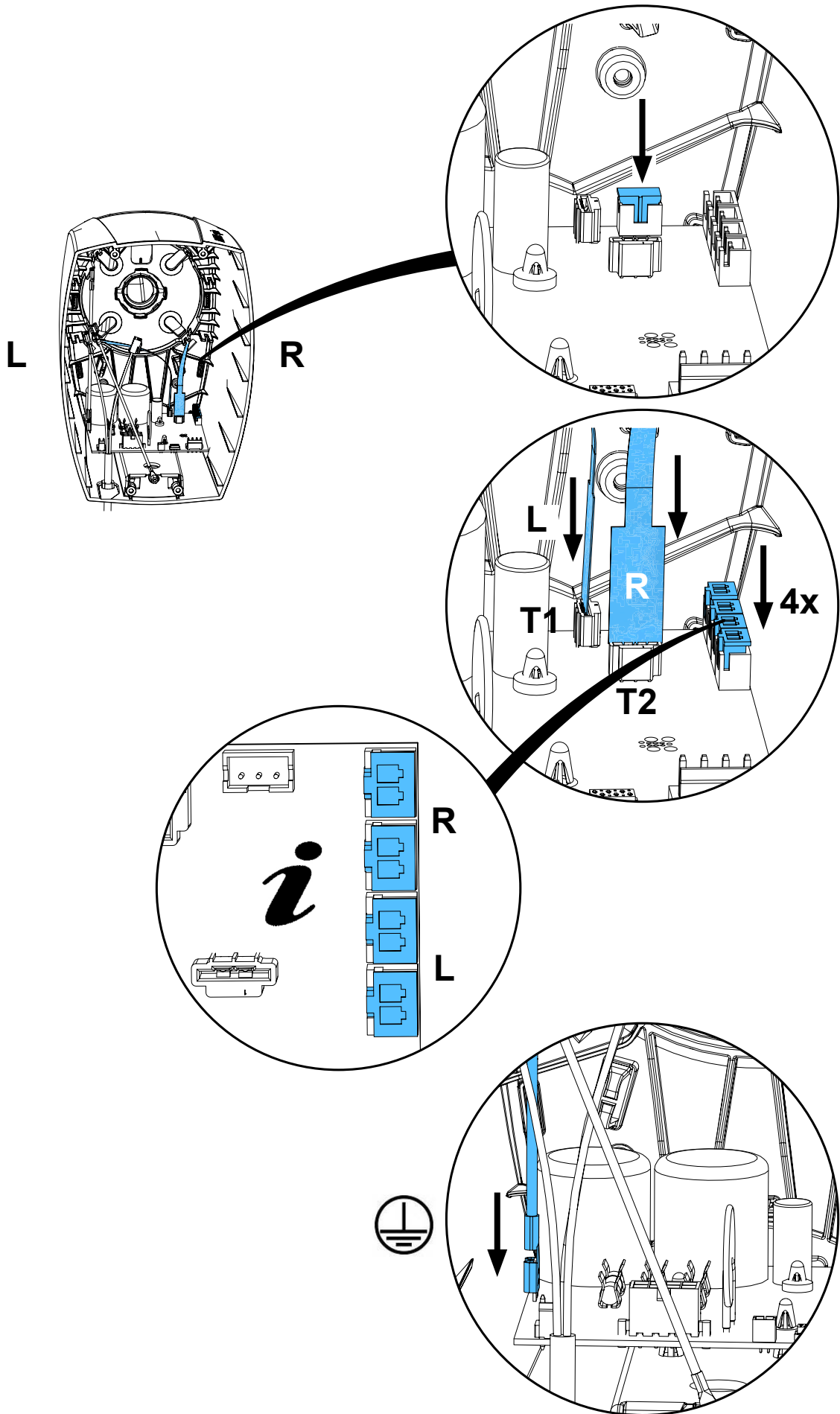

22.

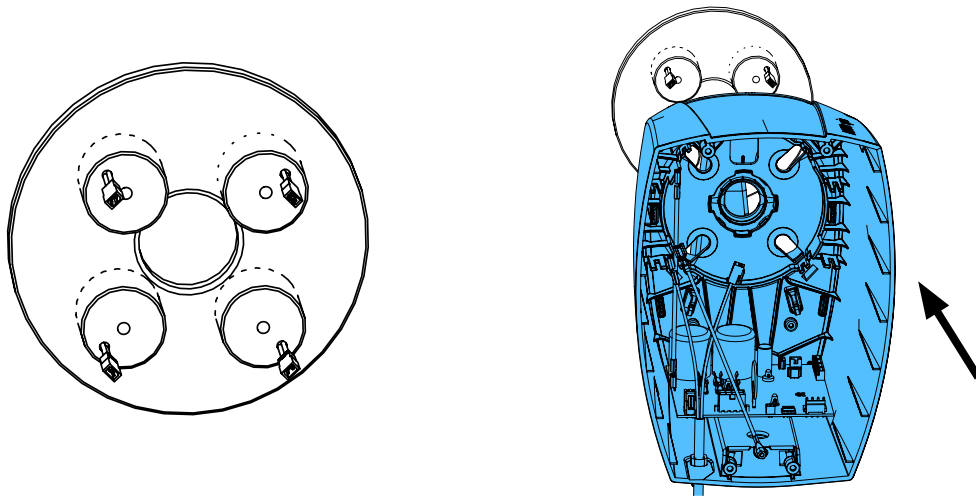

23.

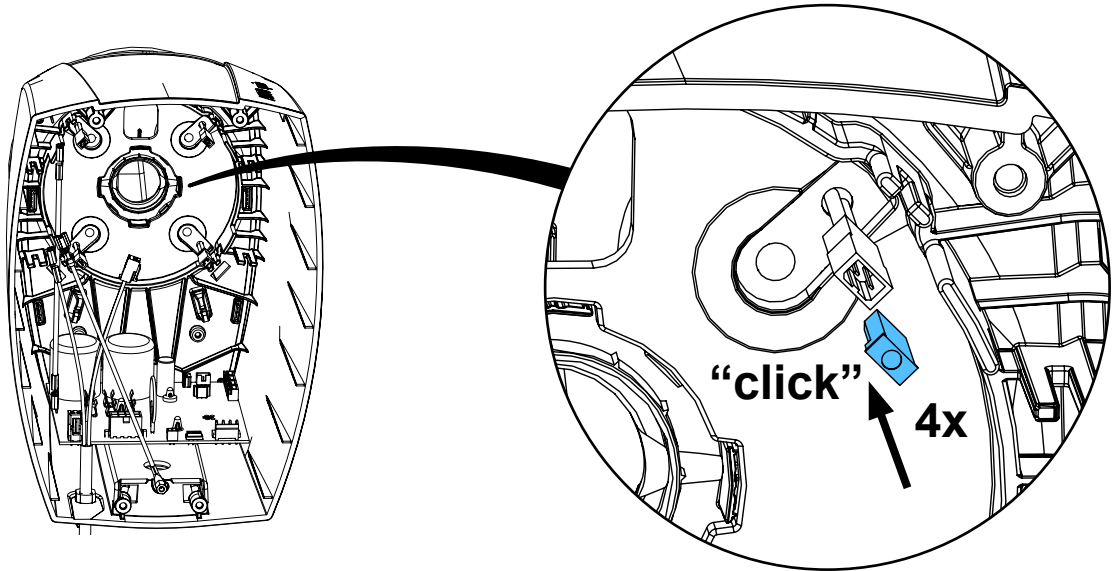

24.

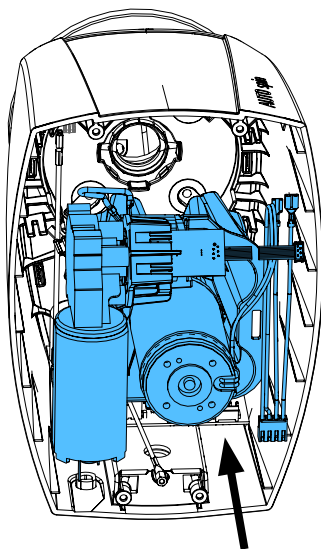

25.

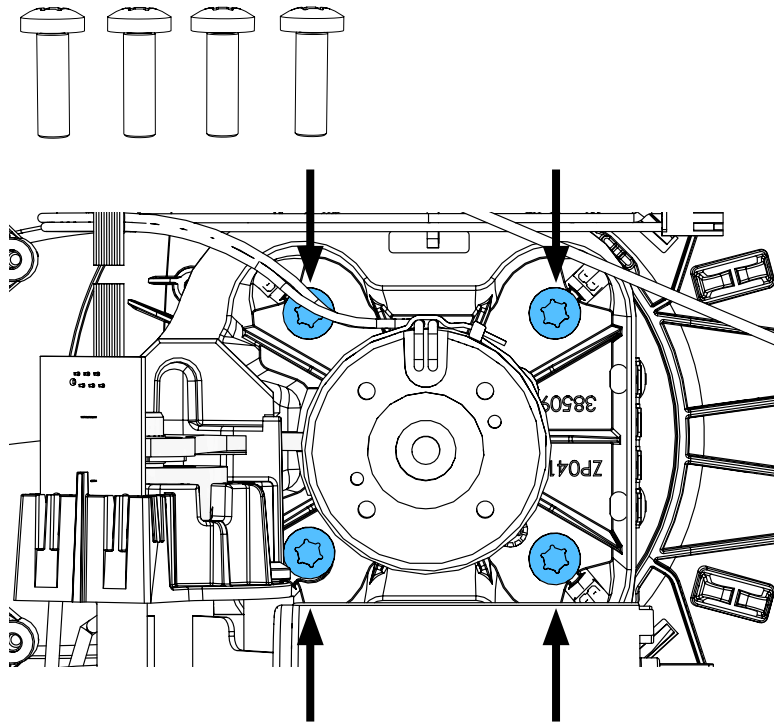

4x
2,5 - 3,0 Nm

26.

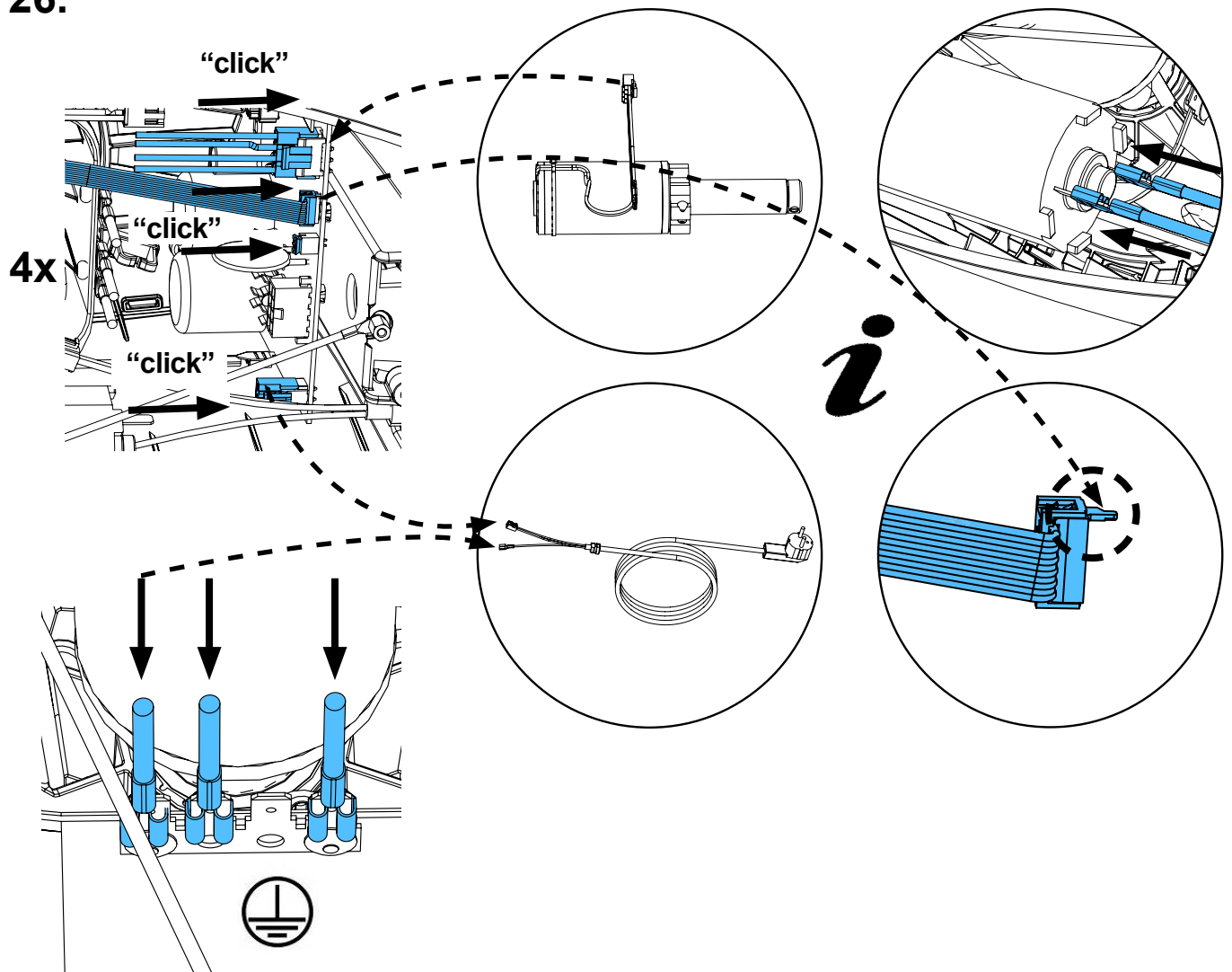

27.

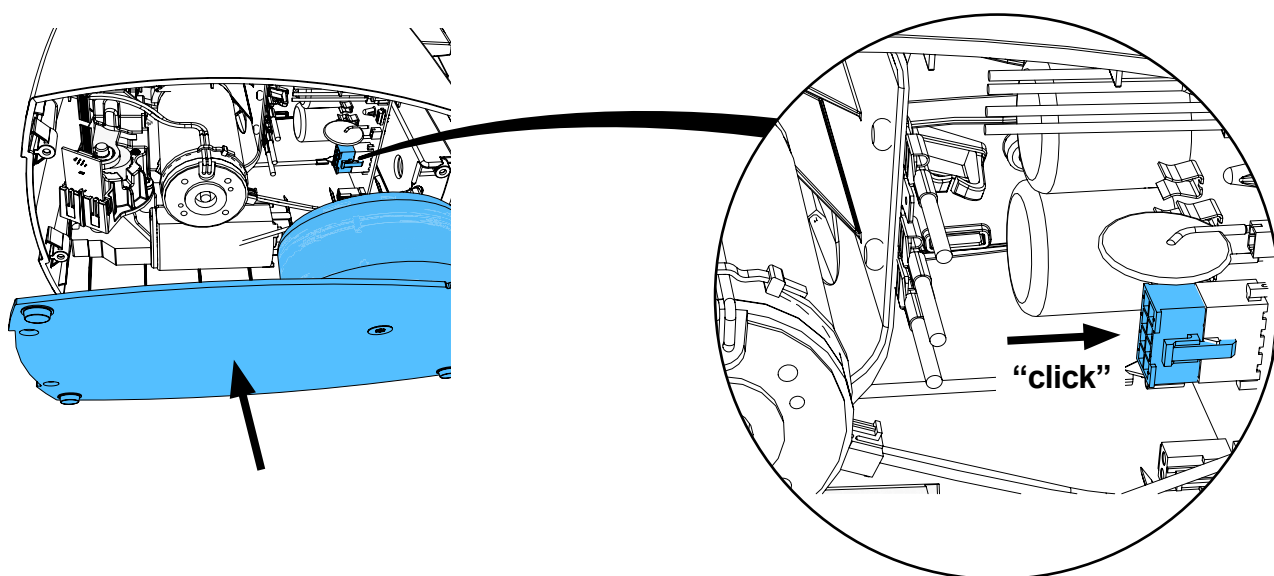

28.

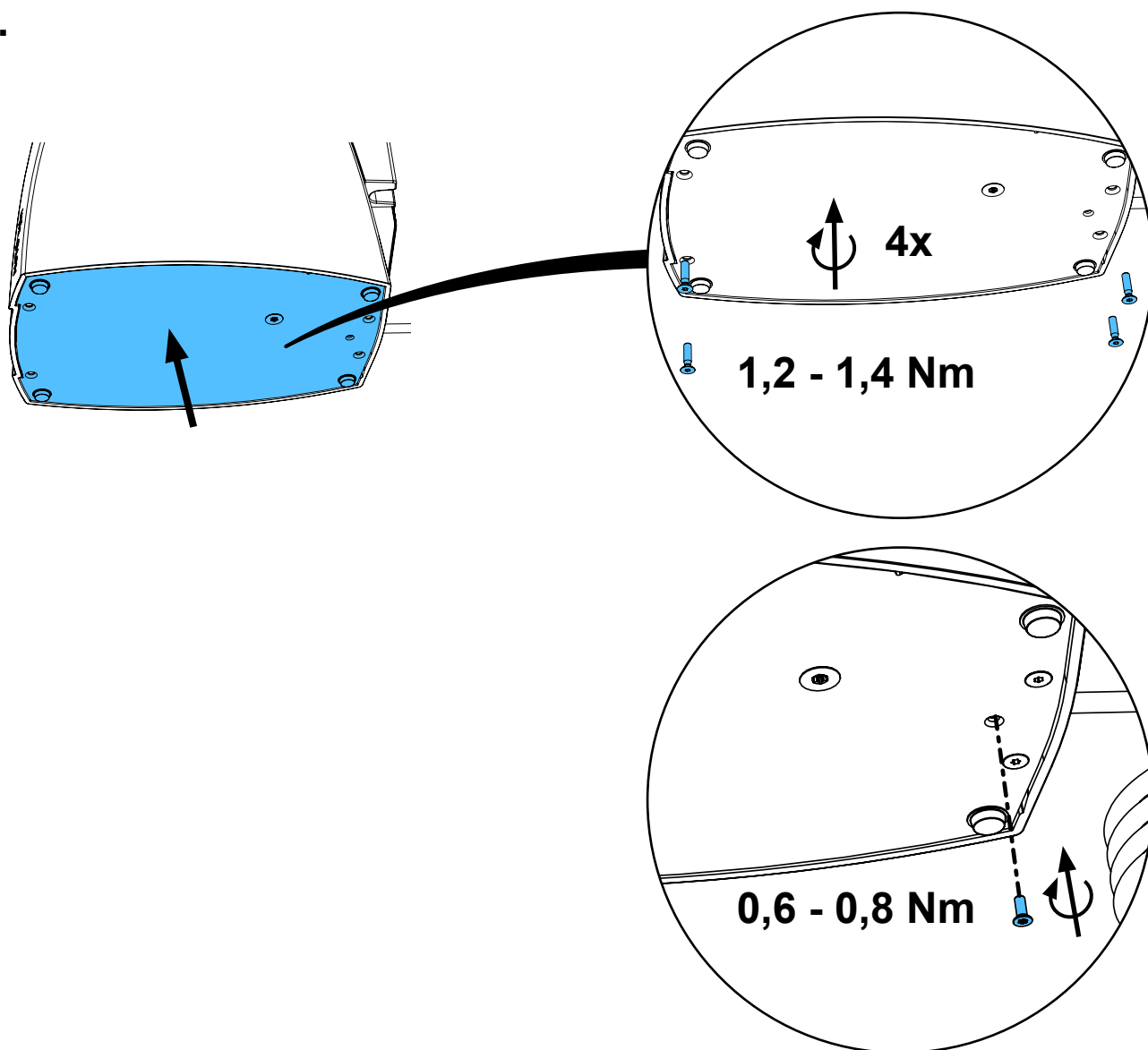

29.



Schutzleiterprüfung durchführen: siehe am Ende der „Service Instructions“.

Performing the protective conductor test: see at the end of the “Service instructions”.

Pour vérifier le conducteur de protection: voir à la fin des “Instructions de service”.

Per la verifica del conduttore di terra: vedere alla fine delle “Istruzioni di servizio”.

Realizar la prueba del conductor de protección: véase al final de las “Instrucciones de servicio”.

Выполнить проверку защитного провода: см. в конце „Инструкции по обслуживанию“.



30.

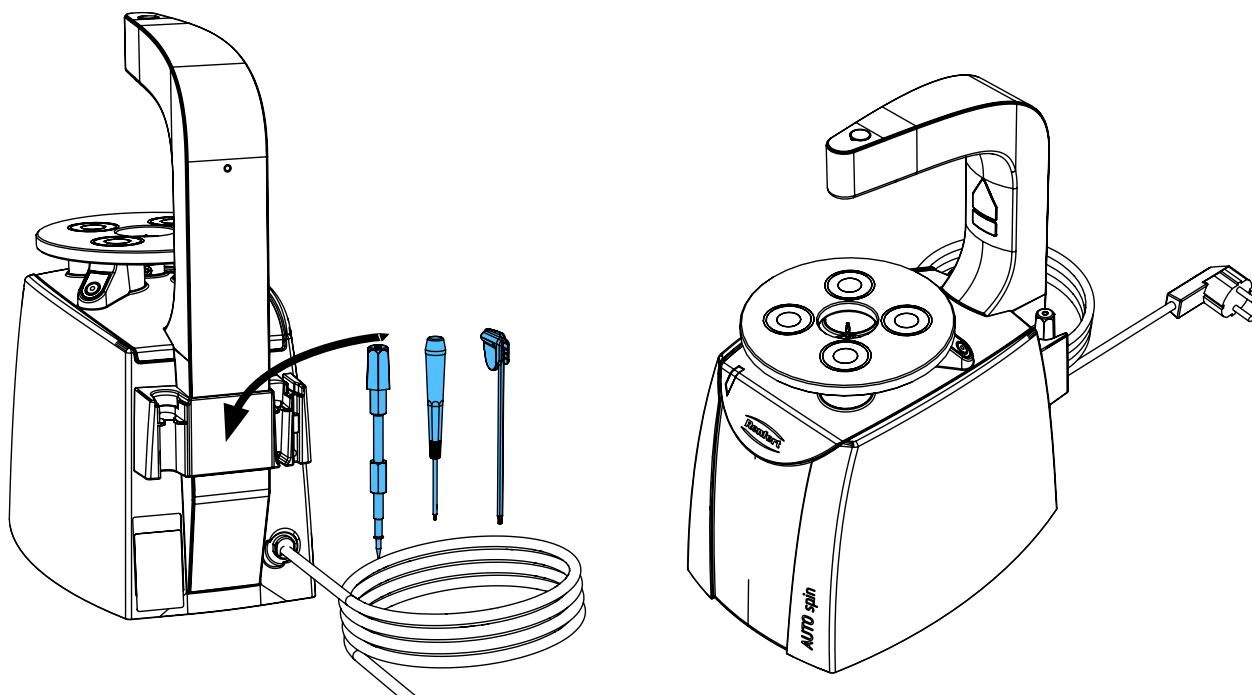



making work easy

90003 7702

Ringkerntrafo • Toroidal core transformer • Transformateur toroidal • Trasforma-
tore a nucleo toroid • Transformador toroidal • Тороидальный трансформатор

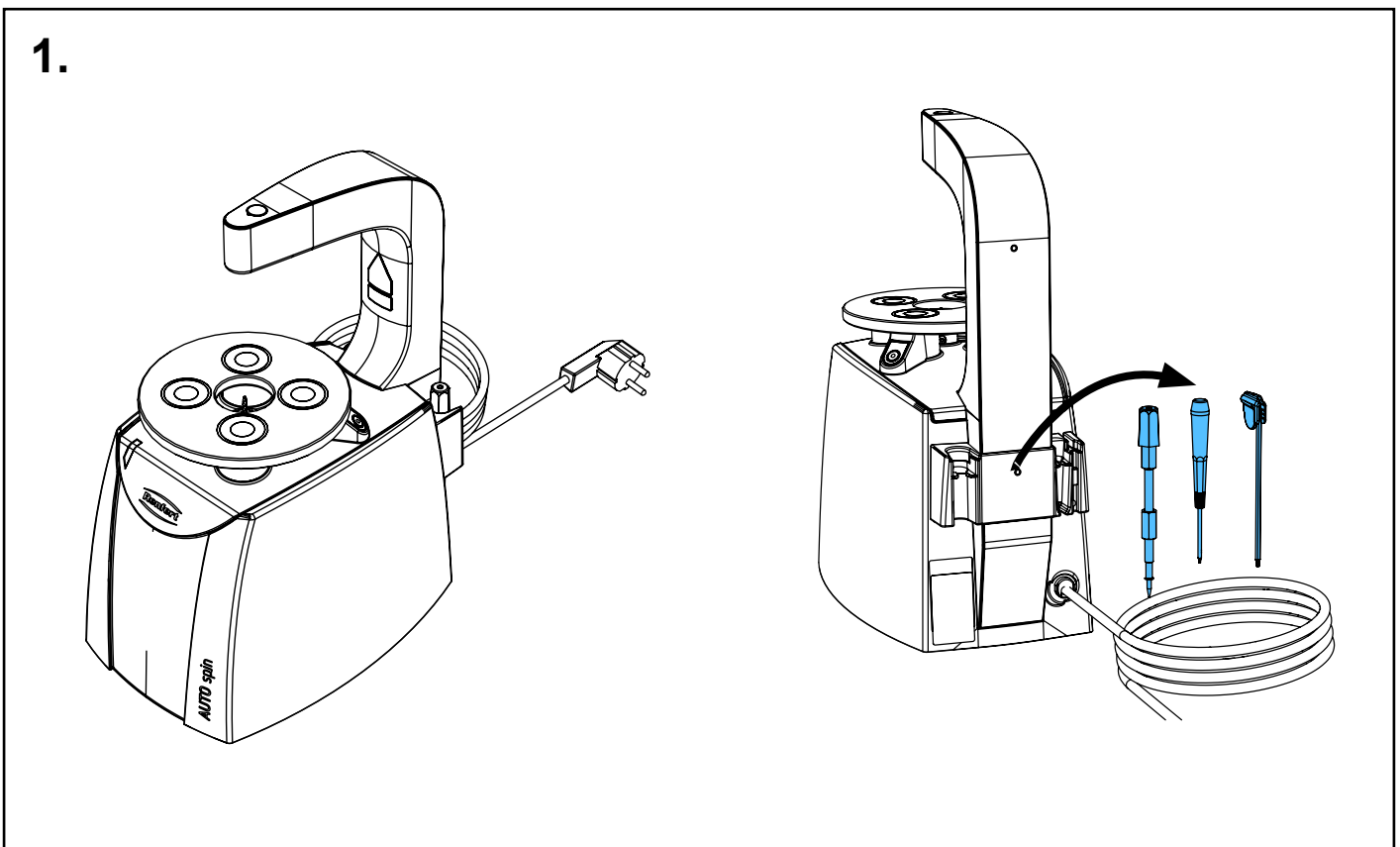
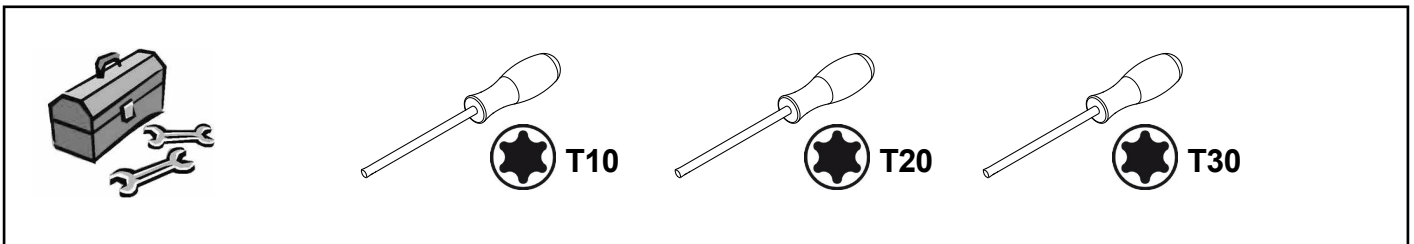
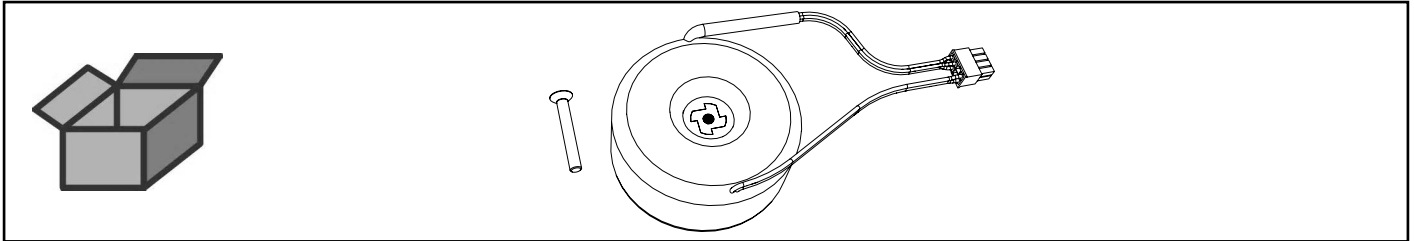

2.

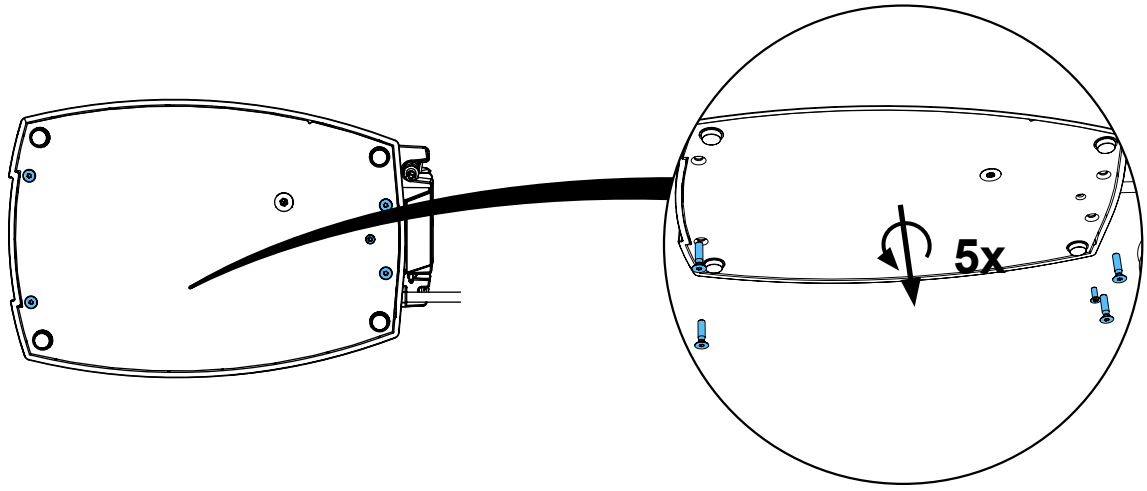

3.

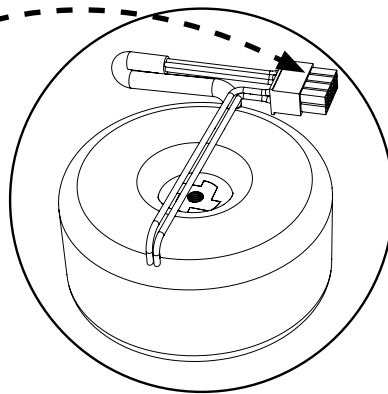
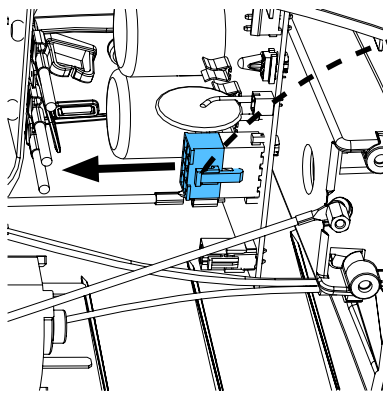
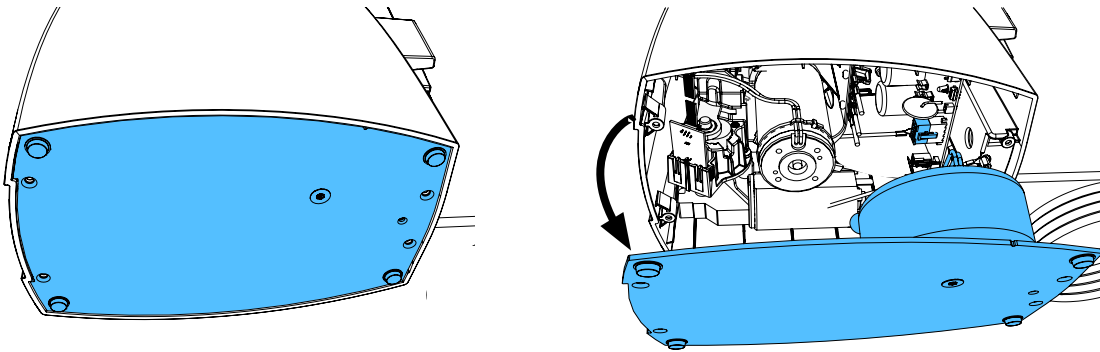

i

4.

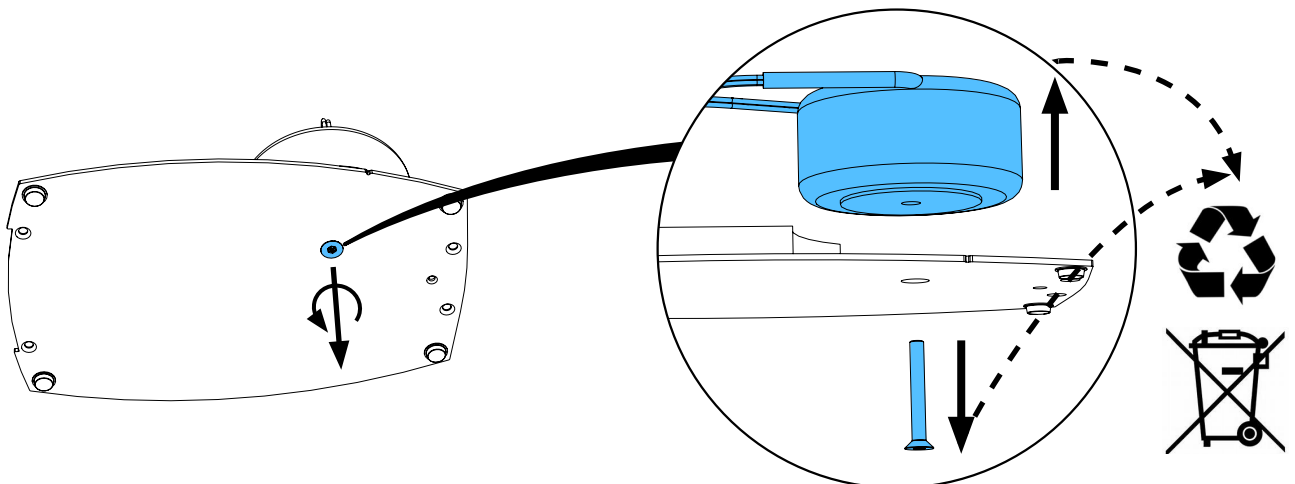

5.

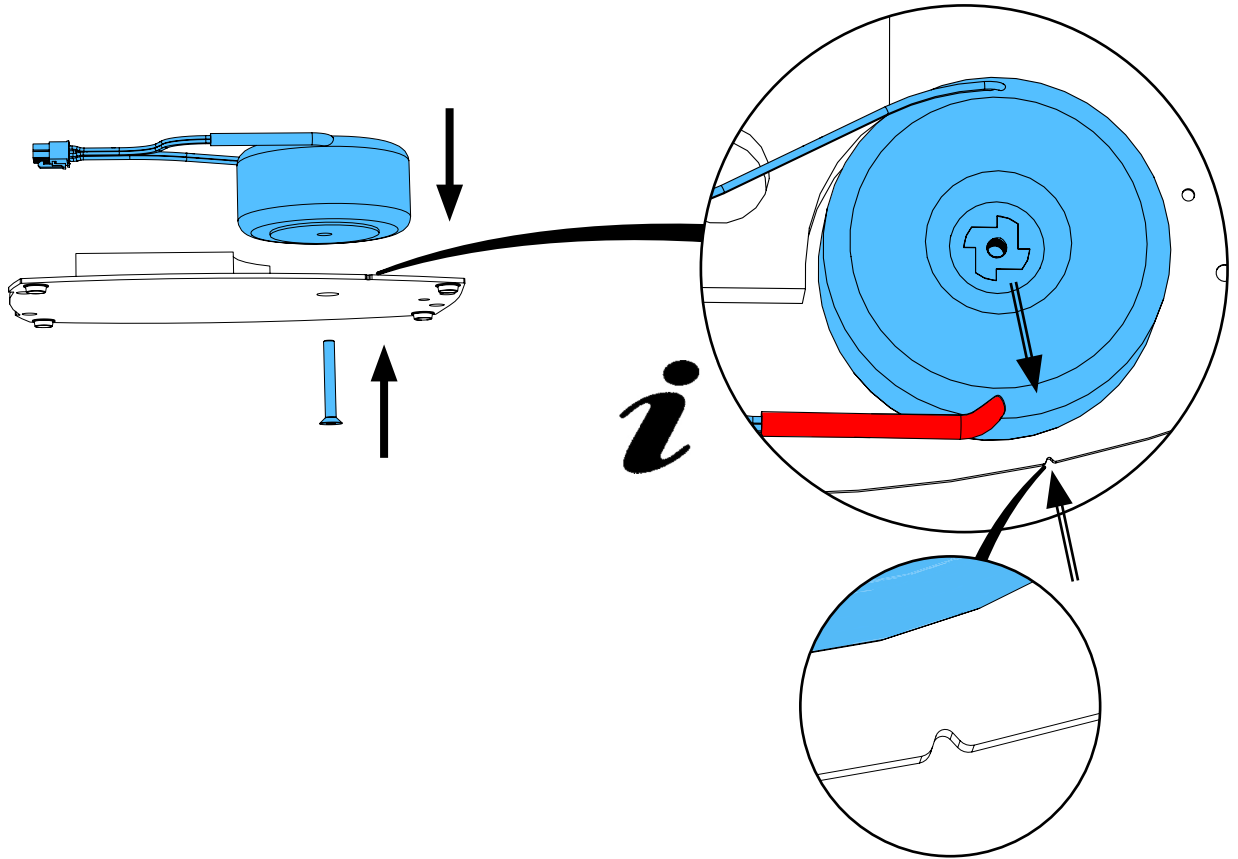

6.

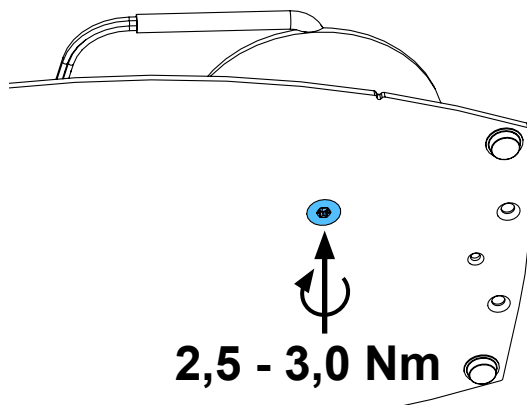

7.

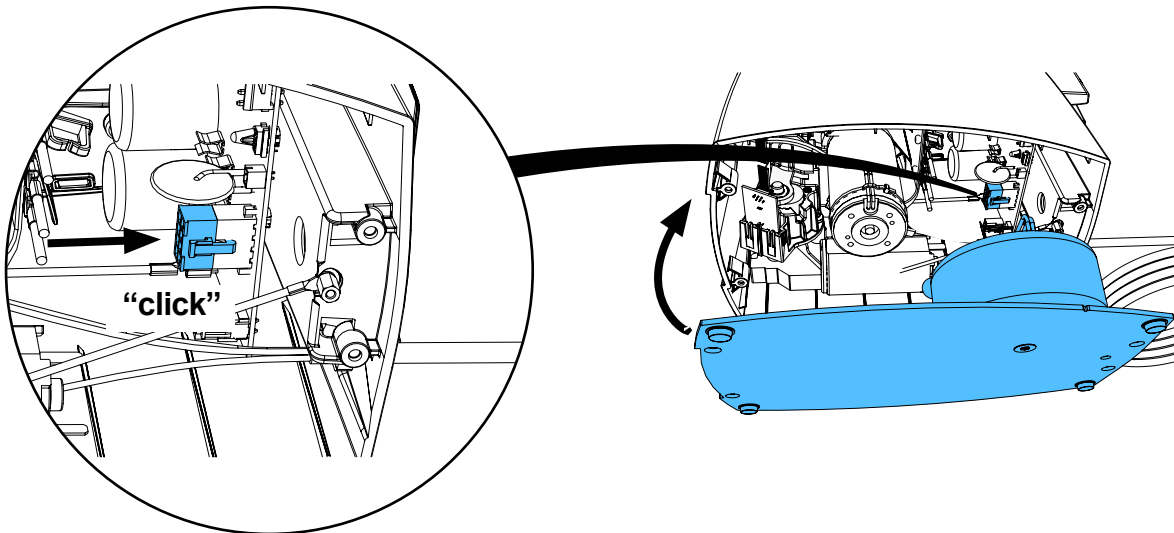

8.

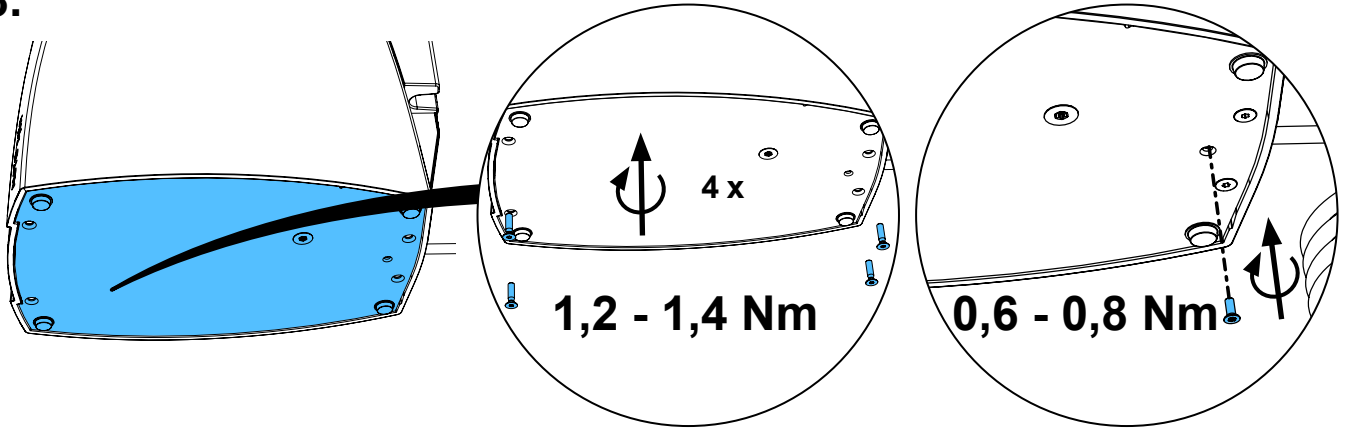

9.



Schutzleiterprüfung durchführen: siehe am Ende der „Service Instructions“.

Performing the protective conductor test: see at the end of the “Service instructions”.

Pour vérifier le conducteur de protection: voir à la fin des “Instructions de service”.

Per la verifica del conduttore di terra: vedere alla fine delle “Istruzioni di servizio”.

Realizar la prueba del conductor de protección: véase al final de las “Instrucciones de servicio”.

Выполнить проверку защитного провода: см. в конце „Инструкции по обслуживанию“.



10.

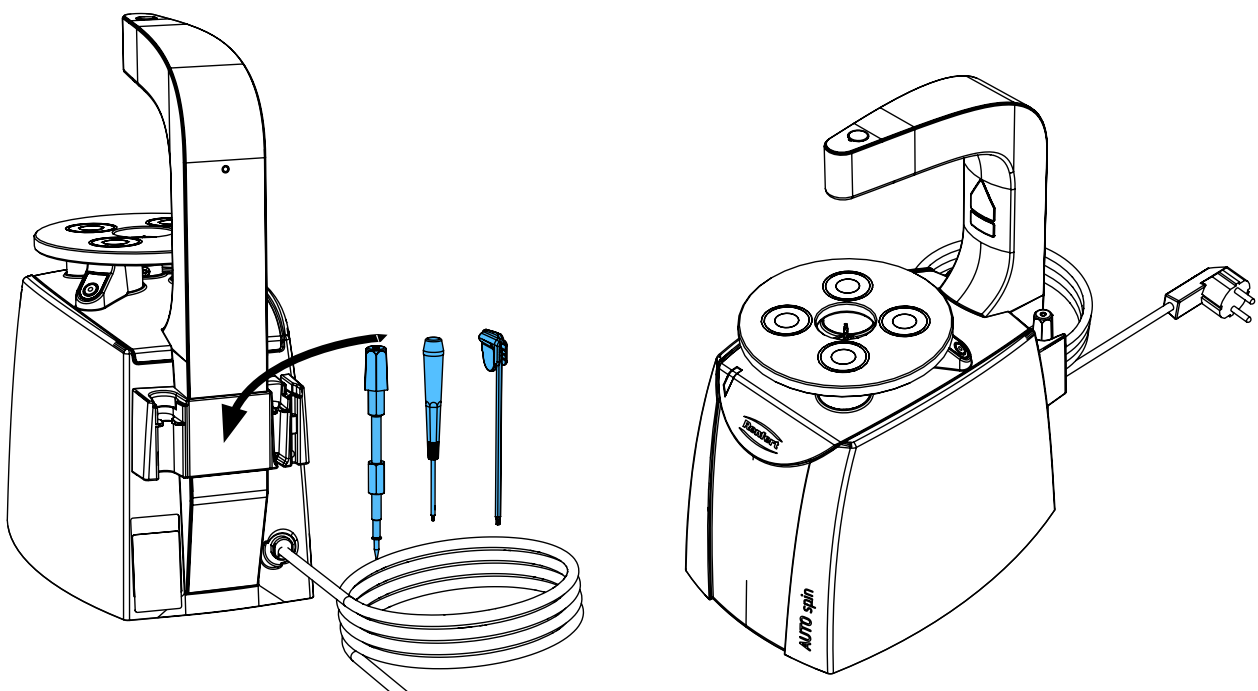



Montageanleitung • Assembly Instruction • Instruction d'installation
Istruzioni l'istallazione • Instrucciones de montaje • Руководство по
монтажу

making work easy

90002 1620

Magnettisch kpl. • Magnetic table cpl. • Table magnétique cpl. • Ripiano magnetico cpl. • Mesa magnética cpl. • Магнитный столик в комплекте

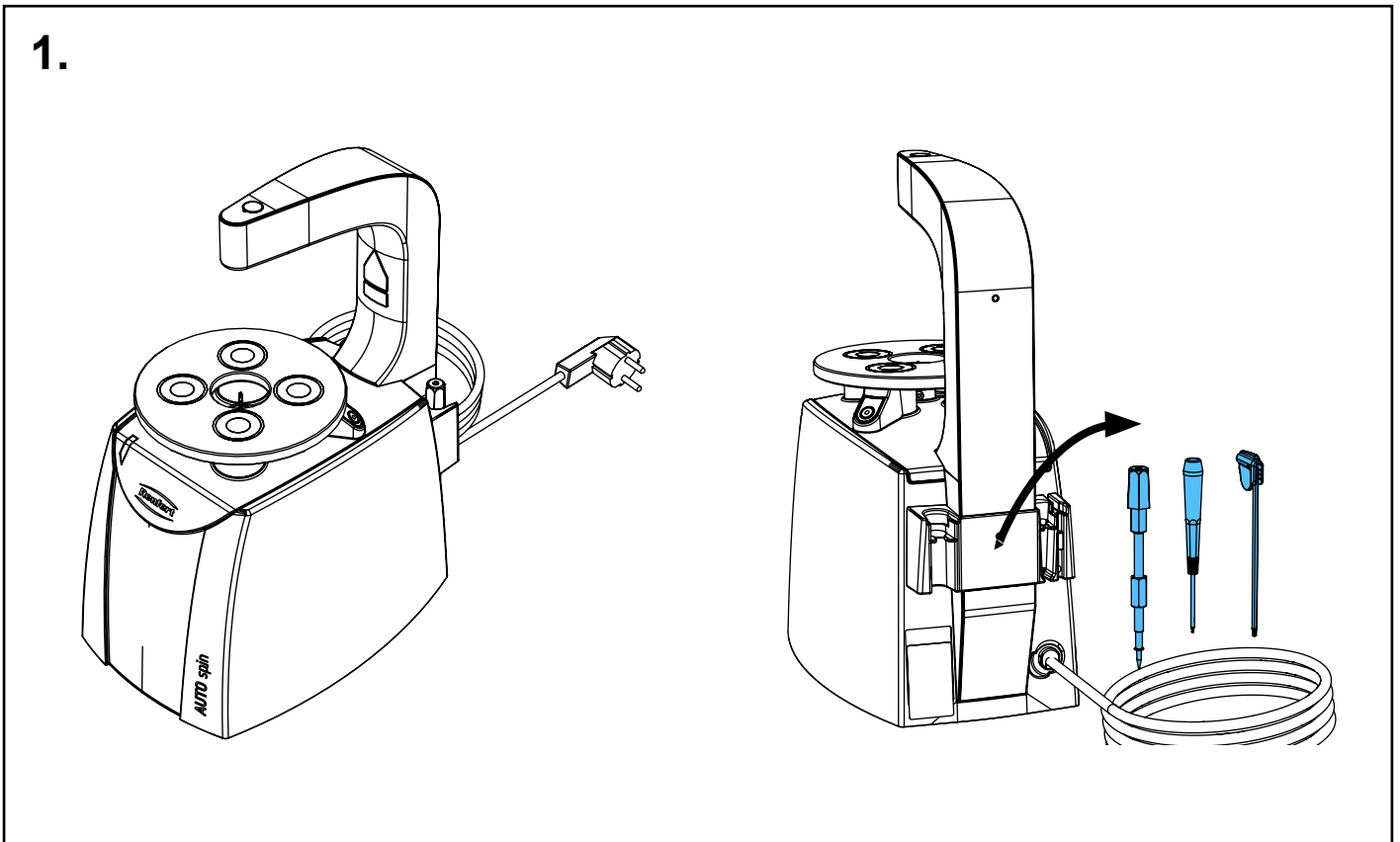
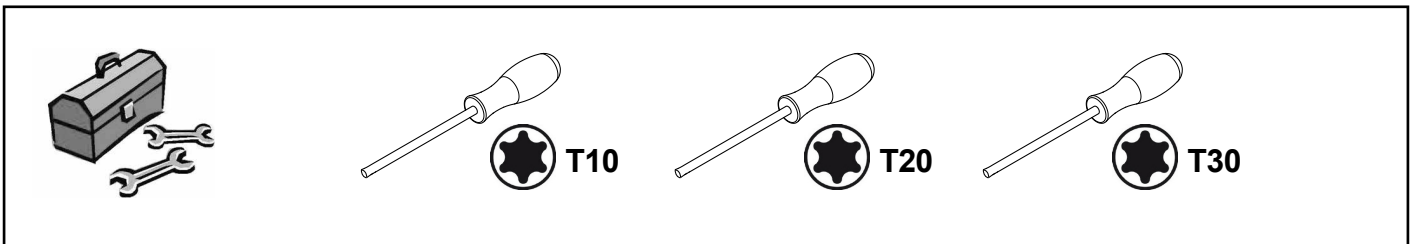
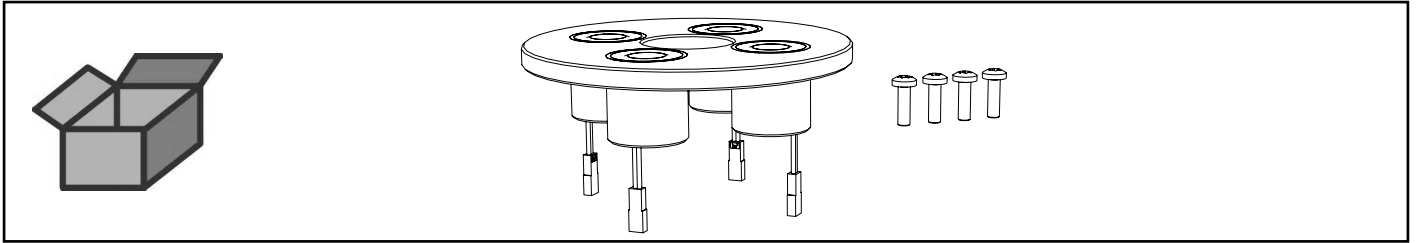

2.

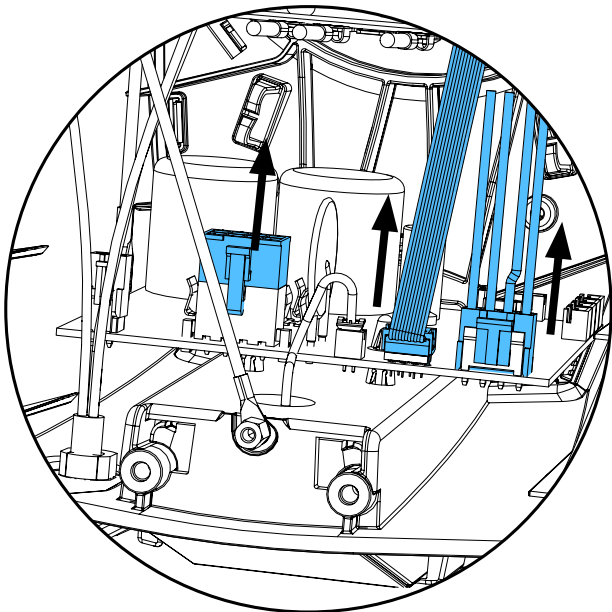
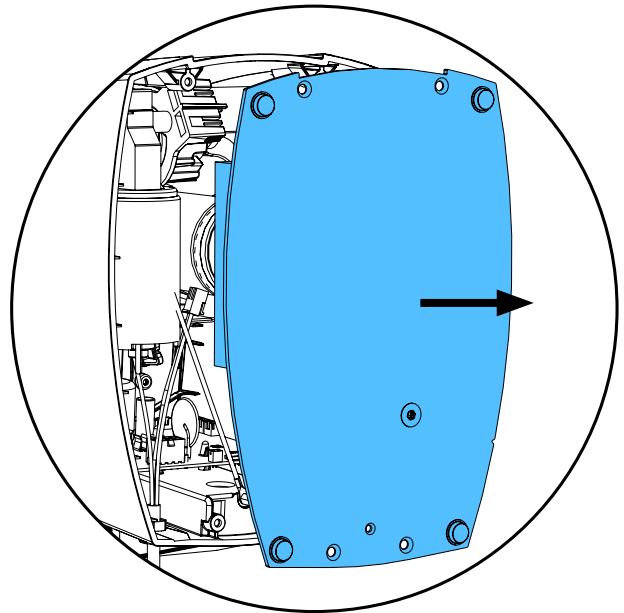
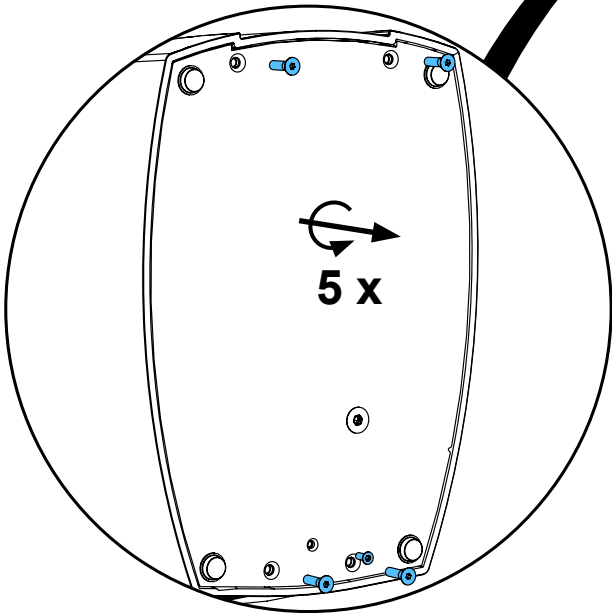
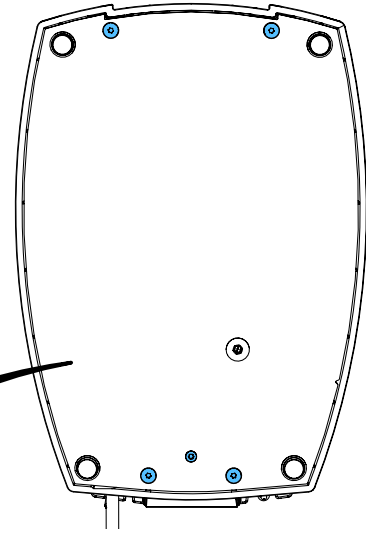
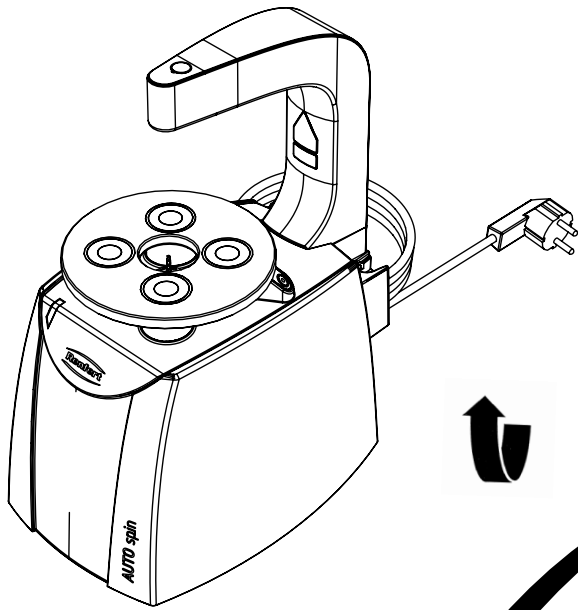

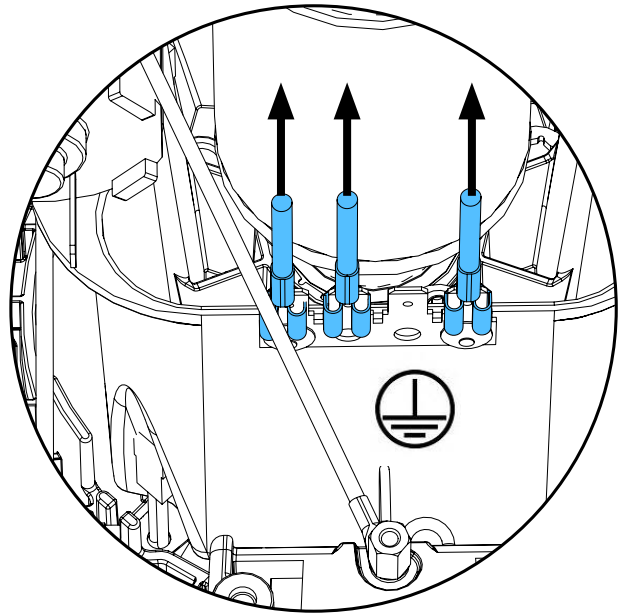
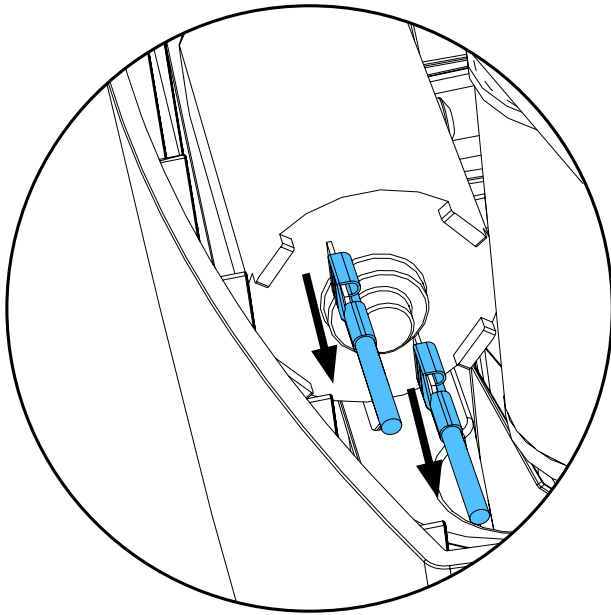

3.

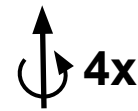
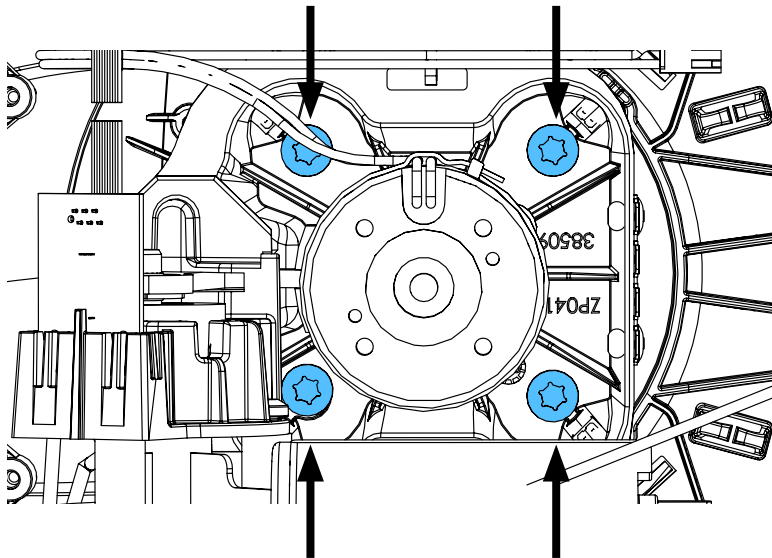

4.

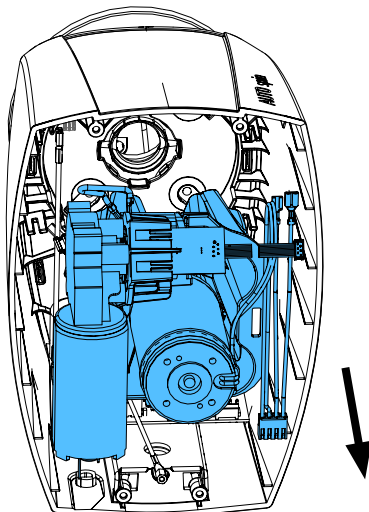

5.

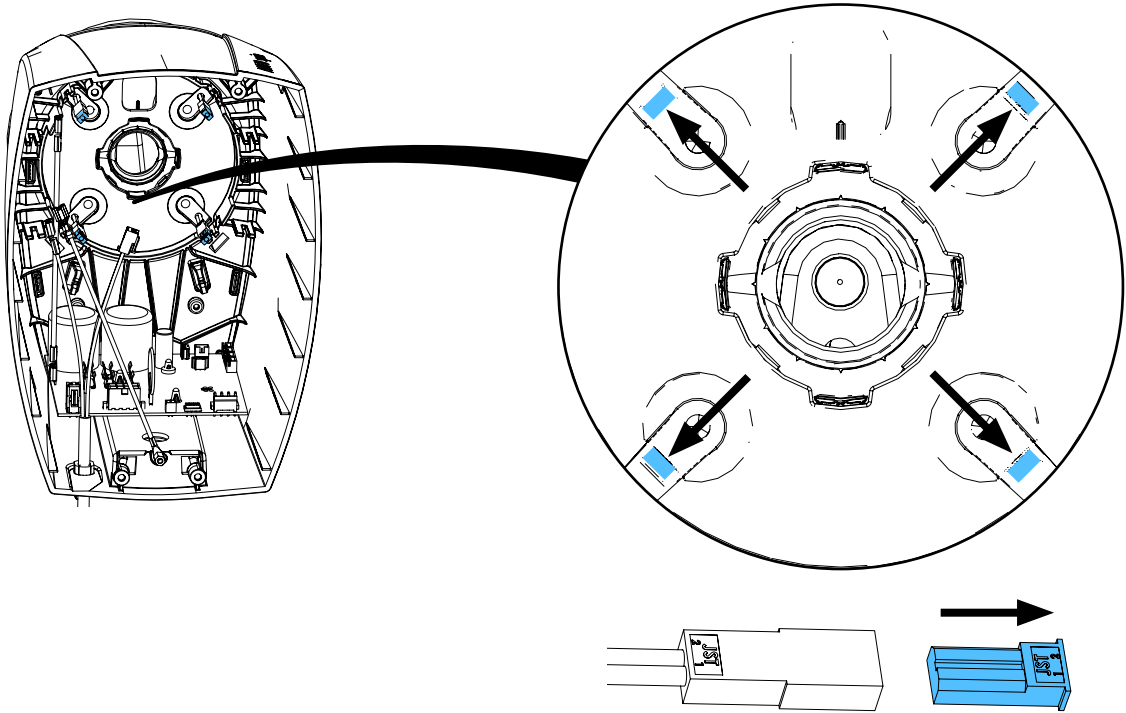

6.

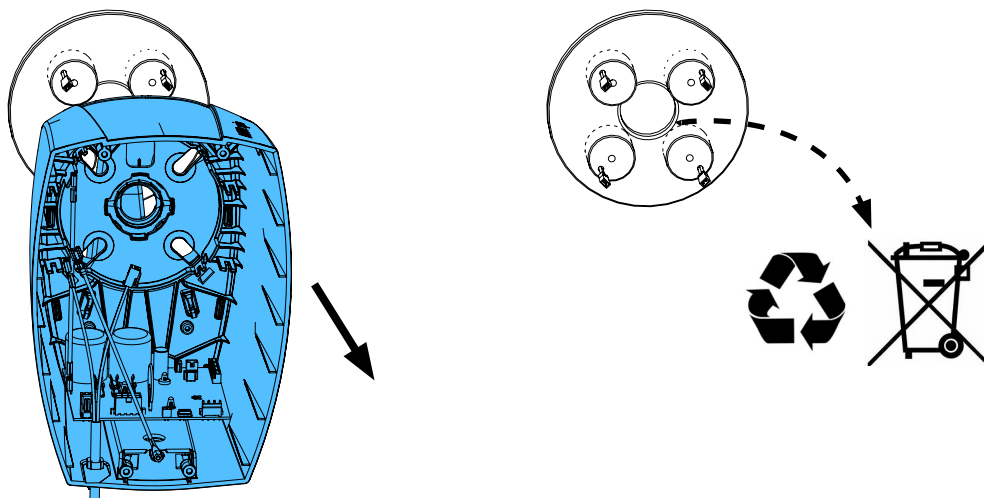

7.

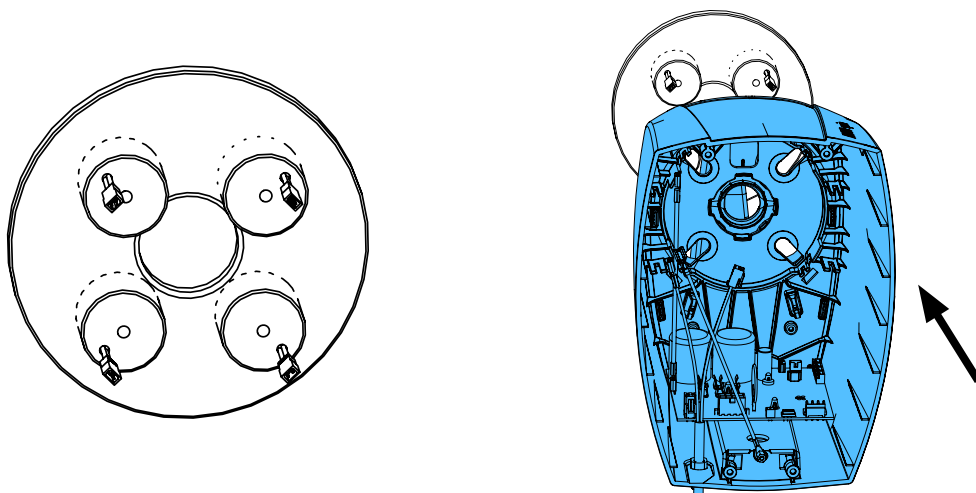

8.

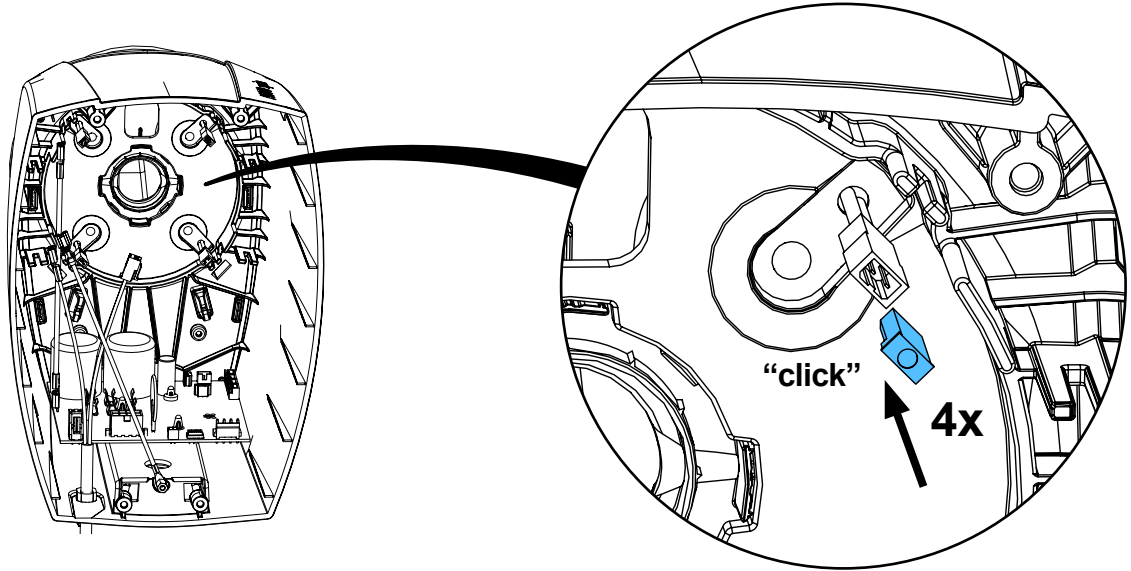

9.

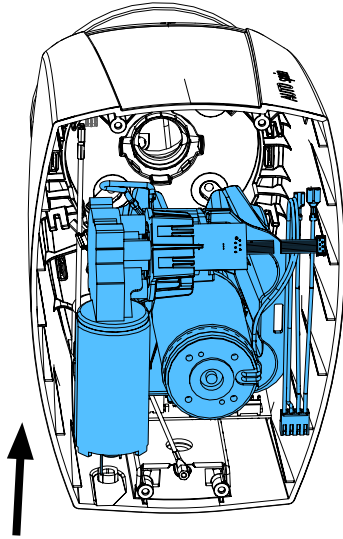

10.

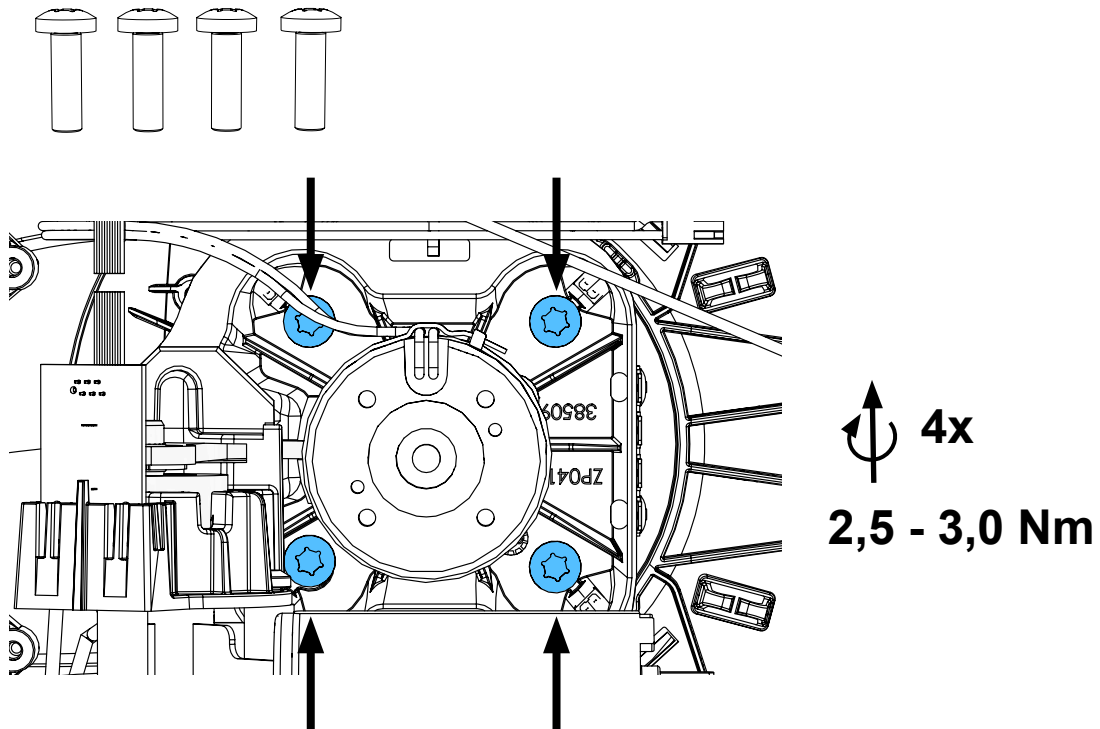

11.

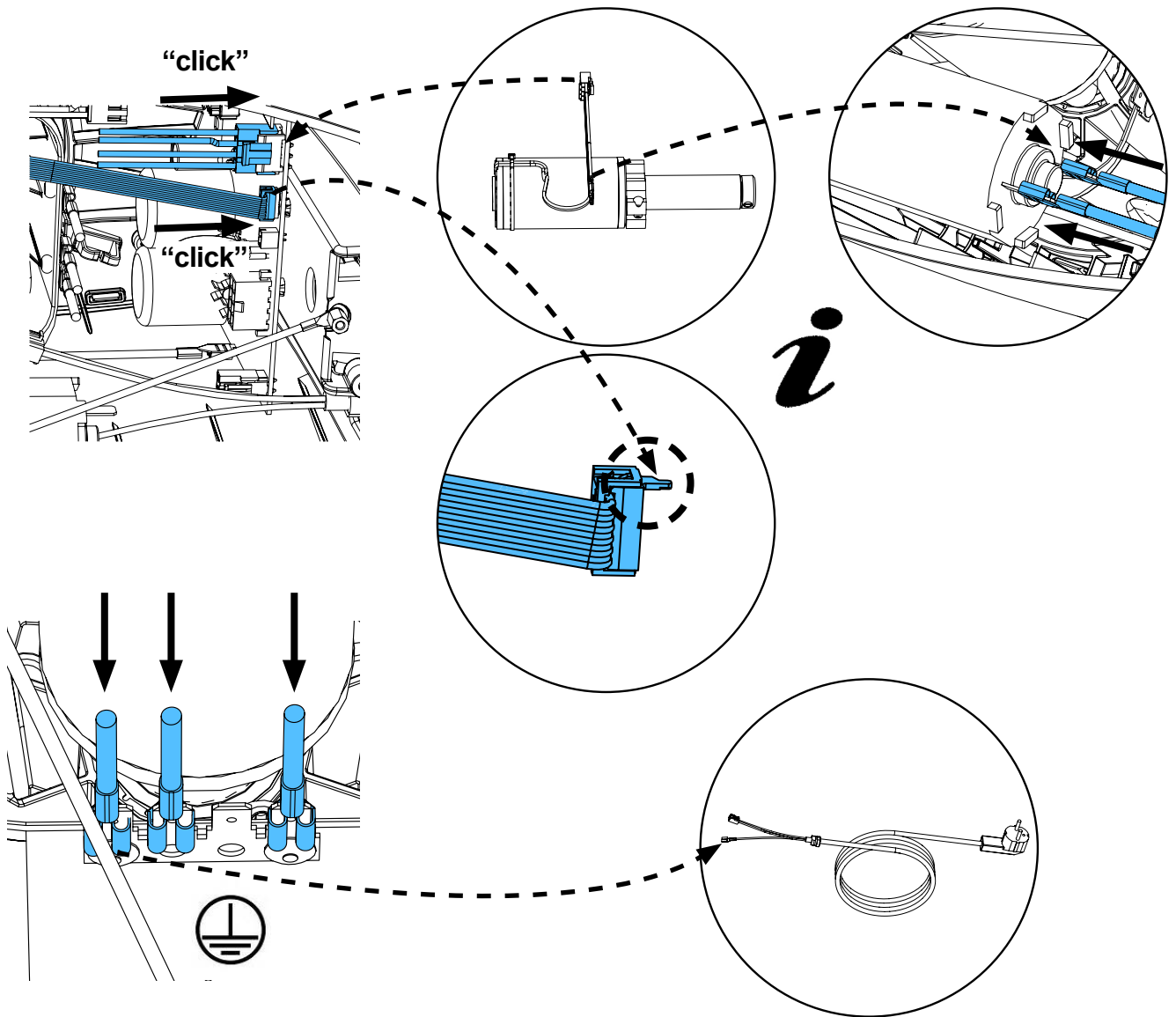

12.

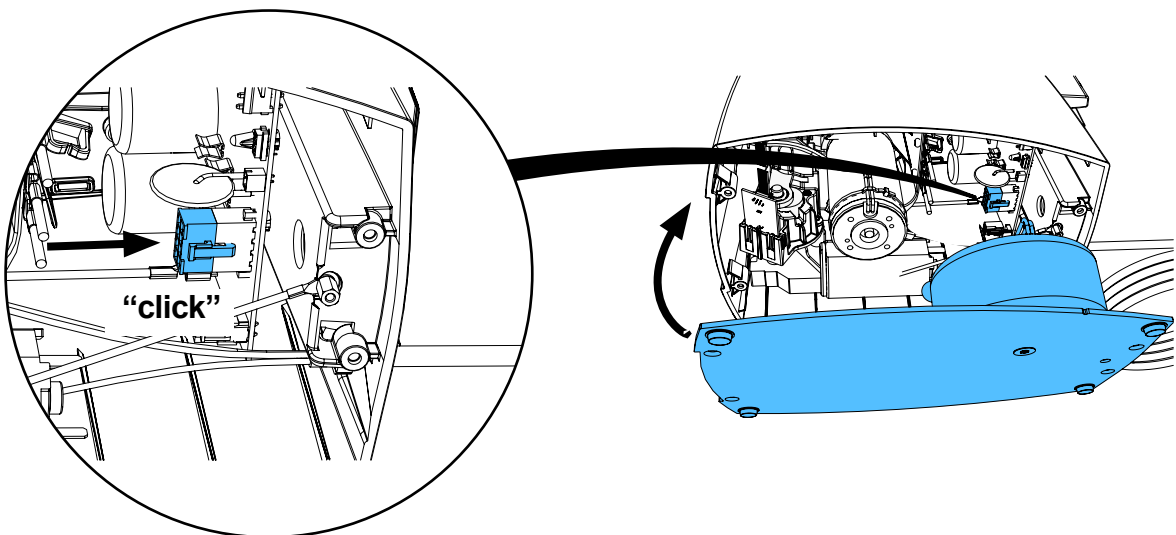

13.

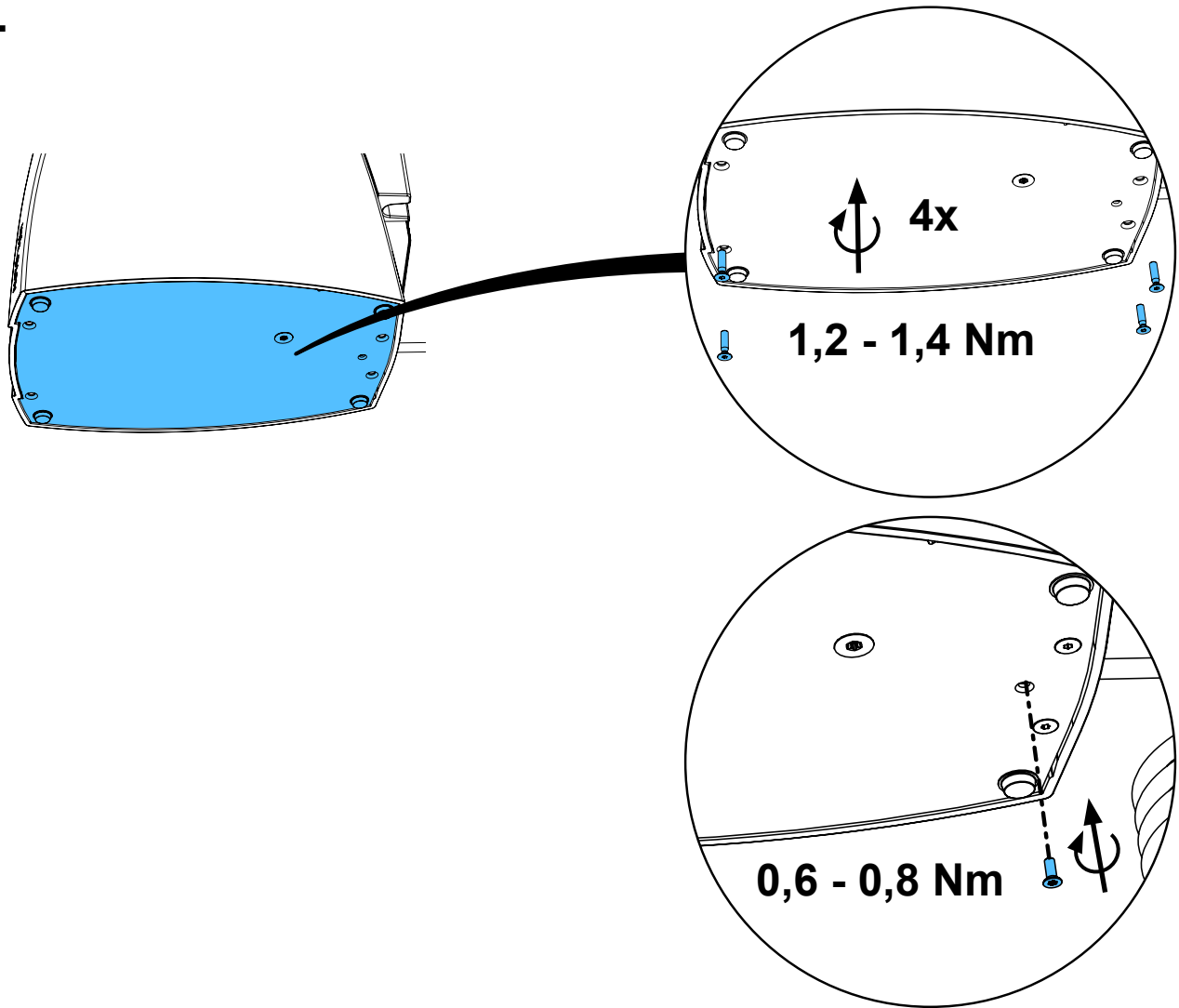

14.



Schutzleiterprüfung durchführen: siehe am Ende der „Service Instructions“.

Performing the protective conductor test: see at the end of the “Service instructions”.

Pour vérifier le conducteur de protection: voir à la fin des “Instructions de service”.

Per la verifica del conduttore di terra: vedere alla fine delle “Istruzioni di servizio”.

Realizar la prueba del conductor de protección: véase al final de las “Instrucciones de servicio”.

Выполнить проверку защитного провода: см. в конце „Инструкции по обслуживанию“.



15.

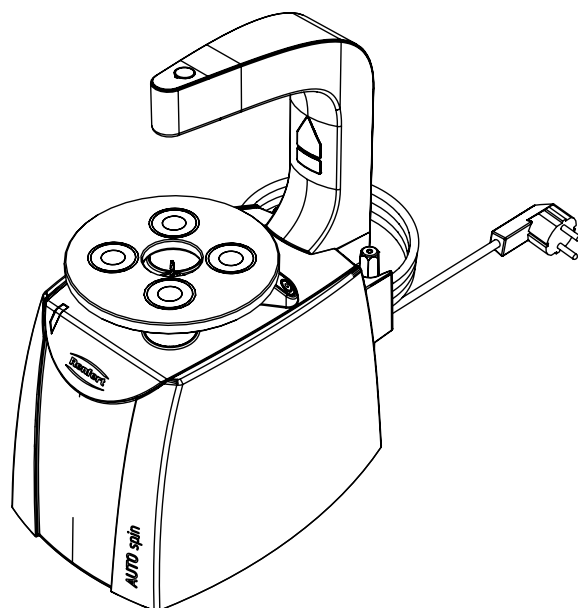
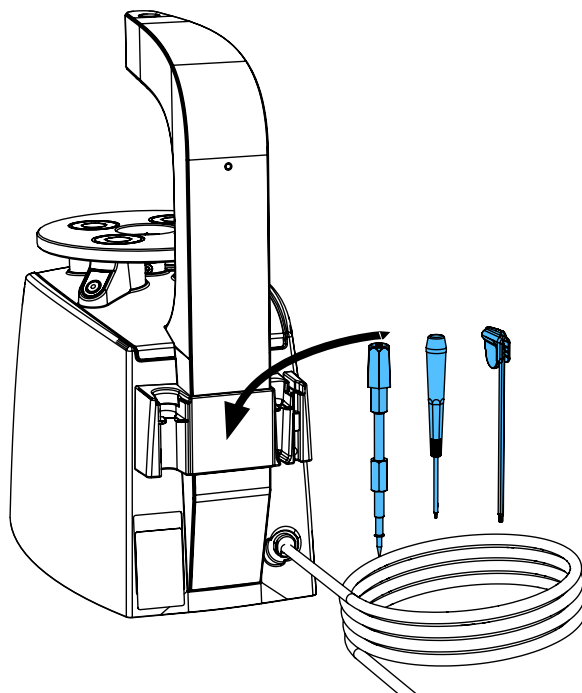



making work easy

90003 7794

Bedienfolie • Operating foil • Feuille de commande • Lamina di comando • Lámi-
na de mando • Плёнка для панели управления

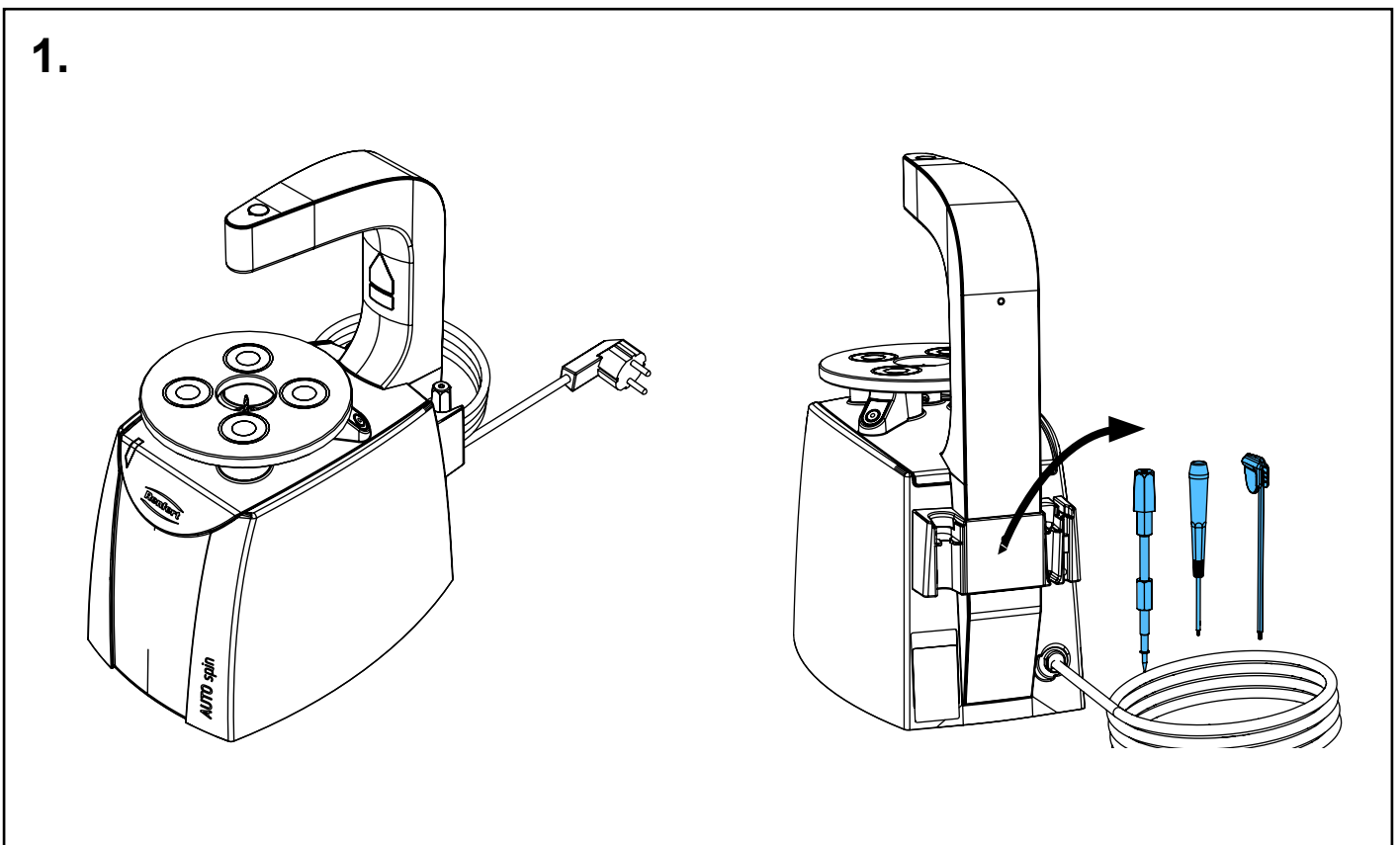
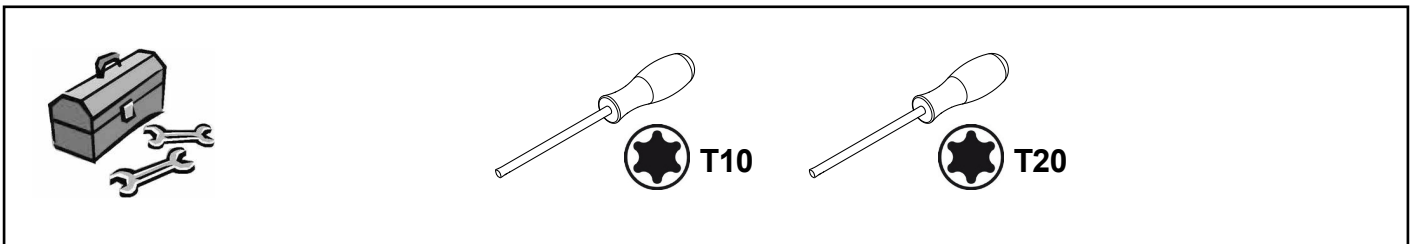
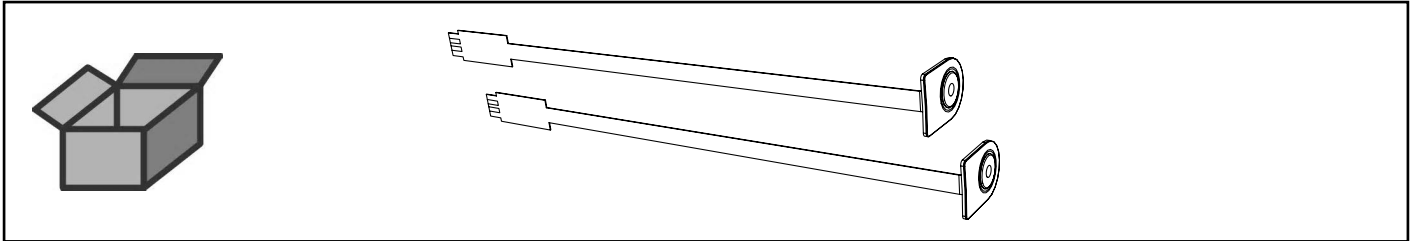

2.

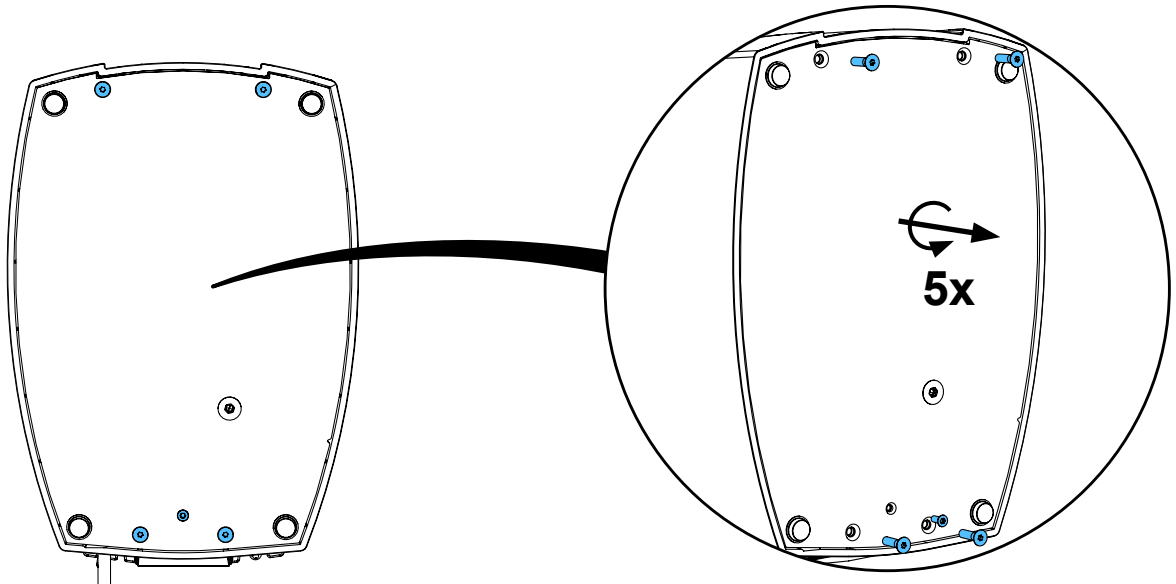
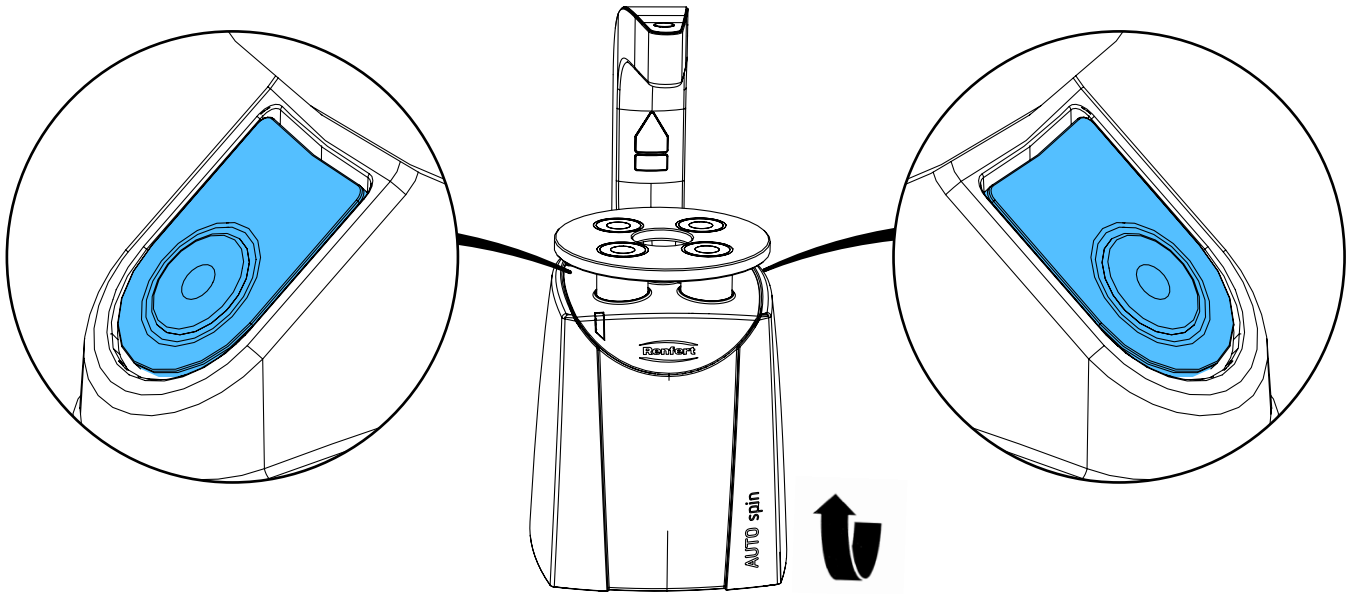

3.

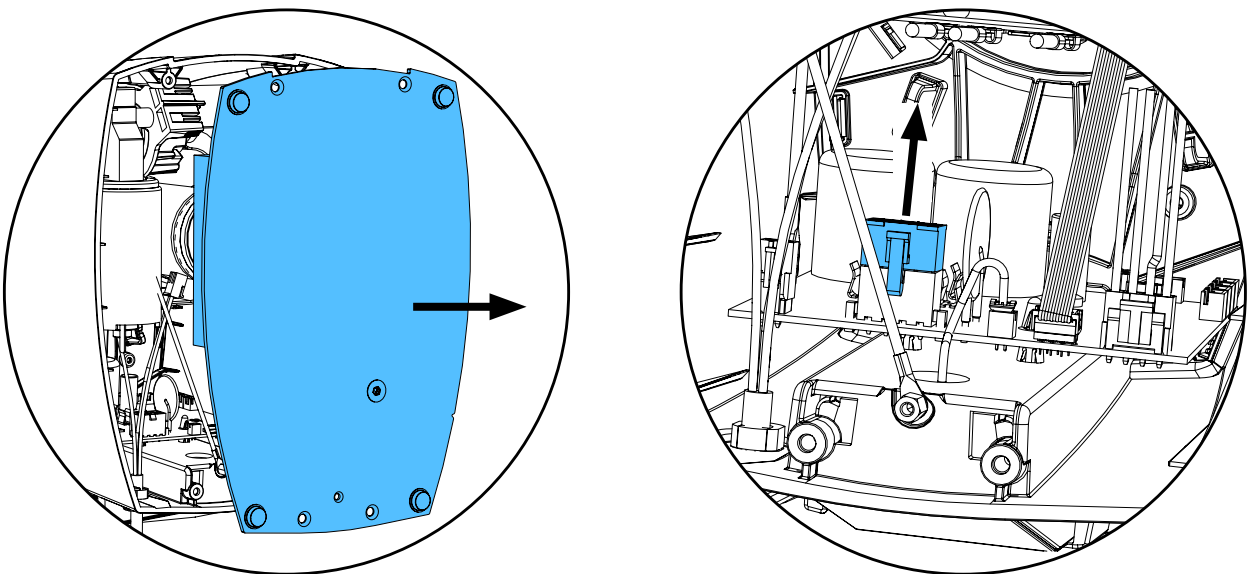

4.

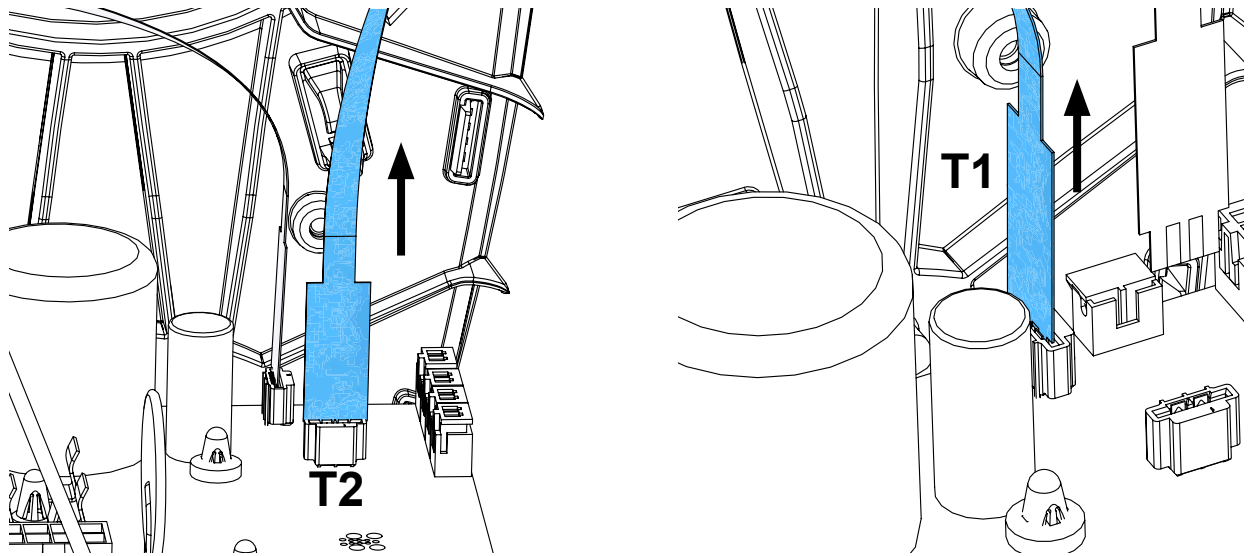

5.

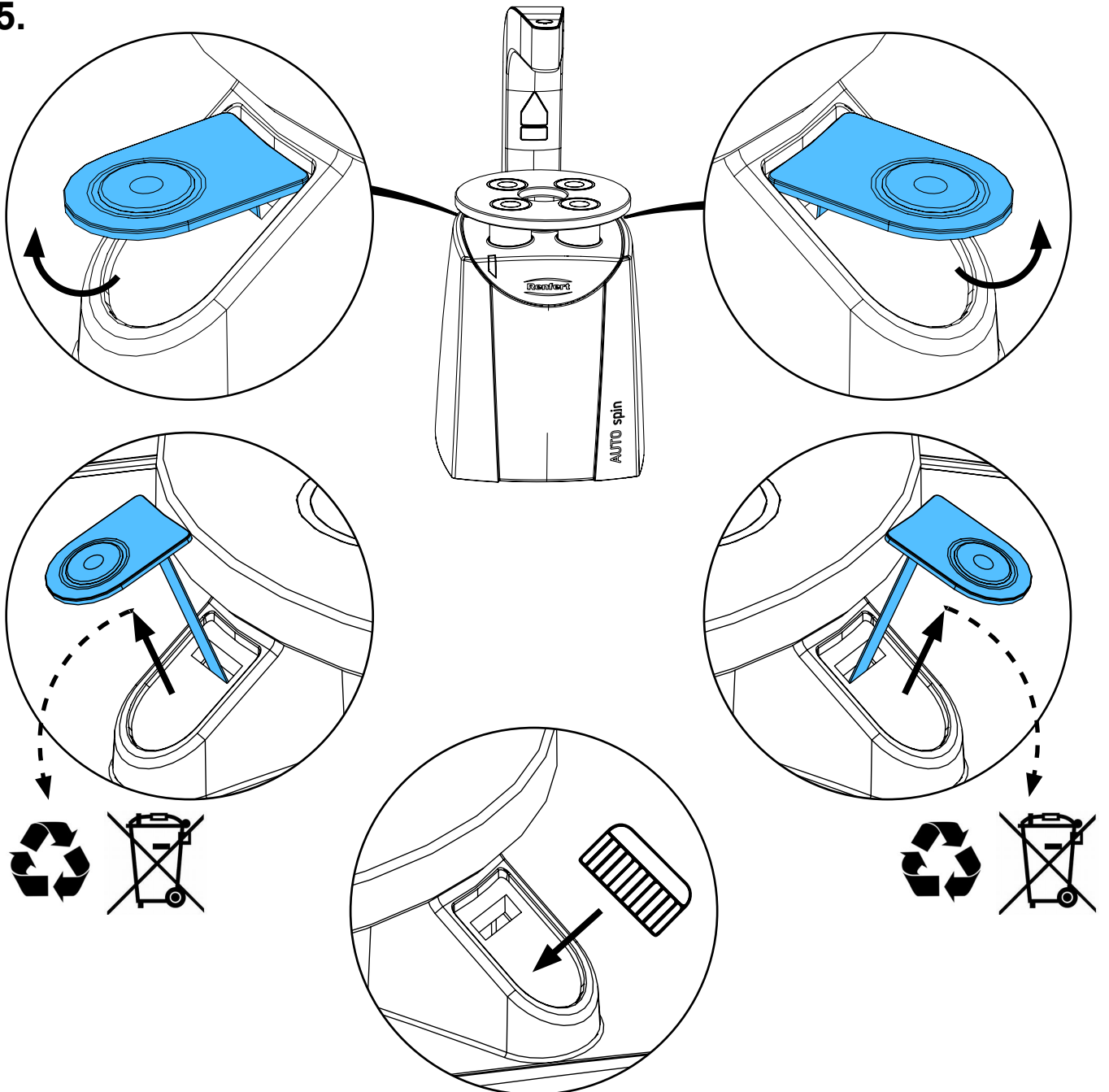

6.

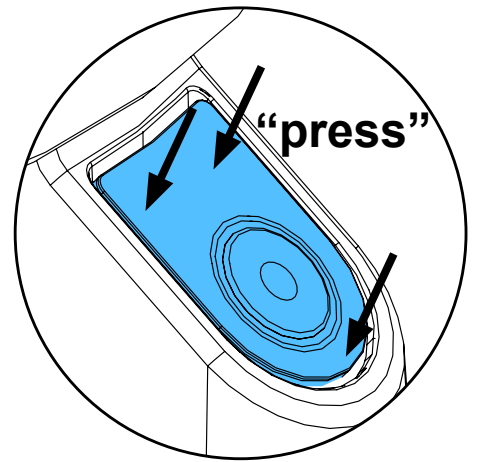
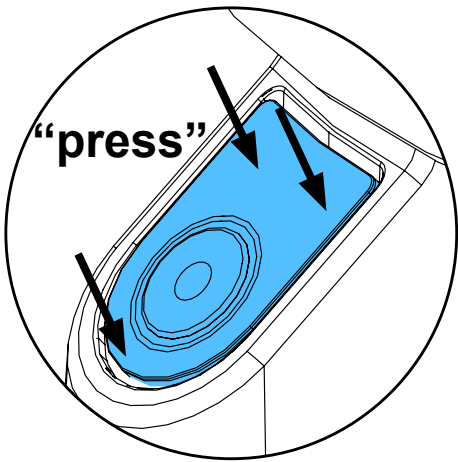
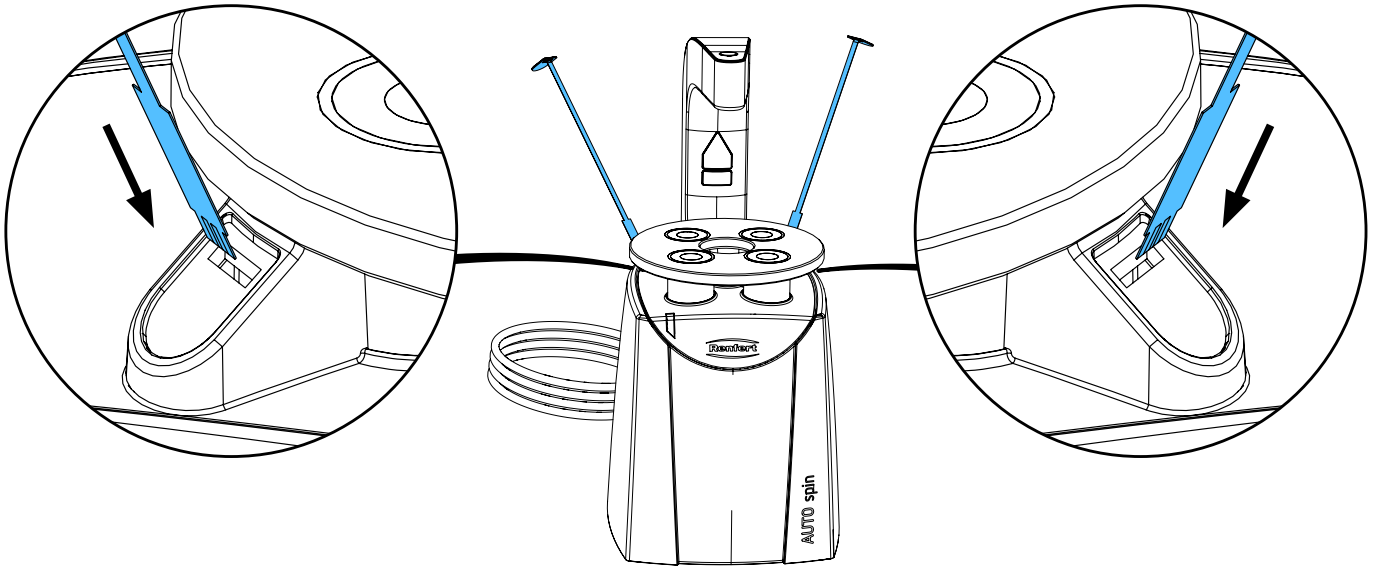

7.

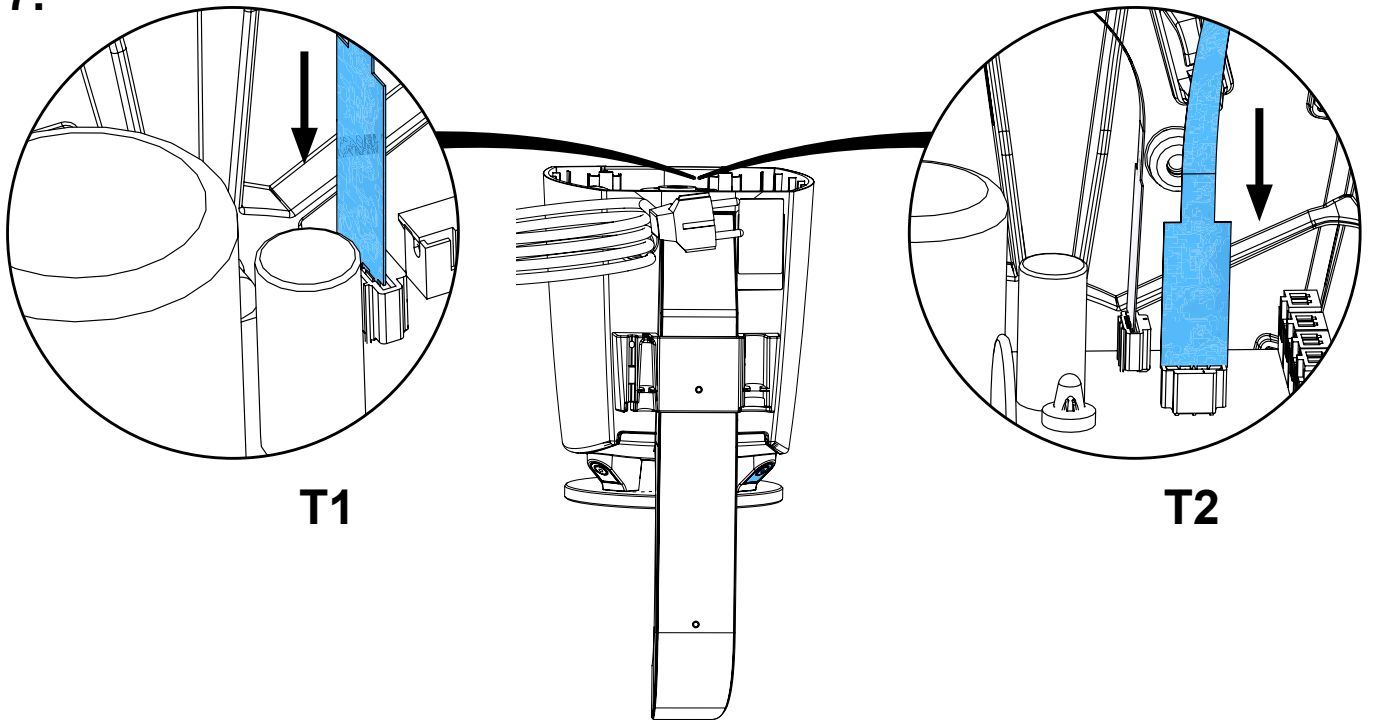

T1

T2

8.

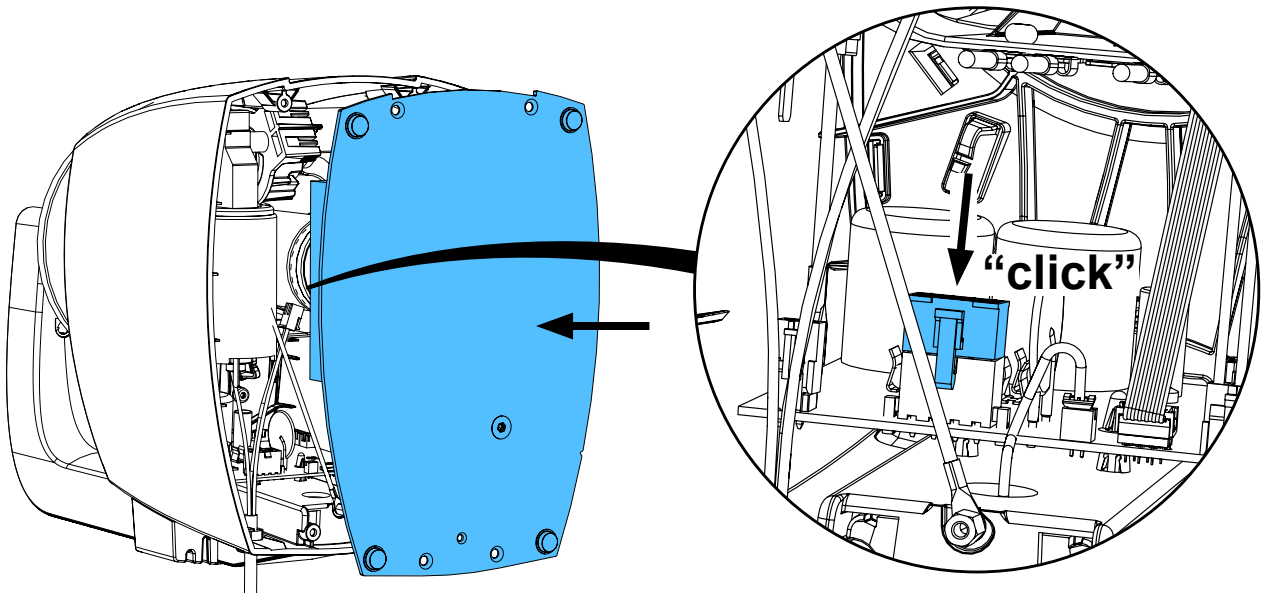

9.

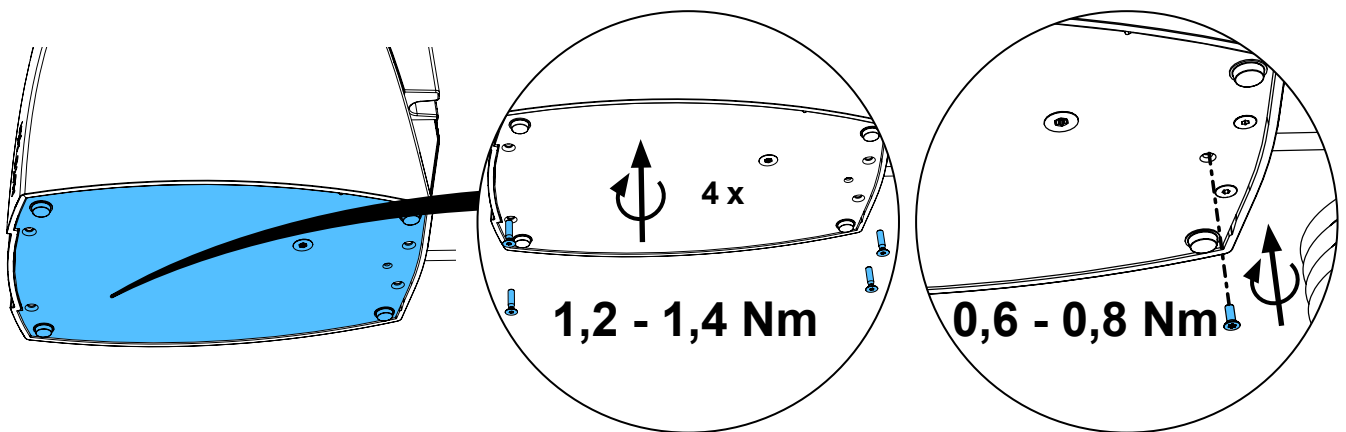

10.



Schutzleiterprüfung durchführen: siehe am Ende der „Service Instructions“.

Performing the protective conductor test: see at the end of the “Service instructions”.

Pour vérifier le conducteur de protection: voir à la fin des “Instructions de service”.

Per la verifica del conduttore di terra: vedere alla fine delle “Istruzioni di servizio”.

Realizar la prueba del conductor de protección: véase al final de las “Instrucciones de servicio”.

Выполнить проверку защитного провода: см. в конце „Инструкции по обслуживанию“.



11.

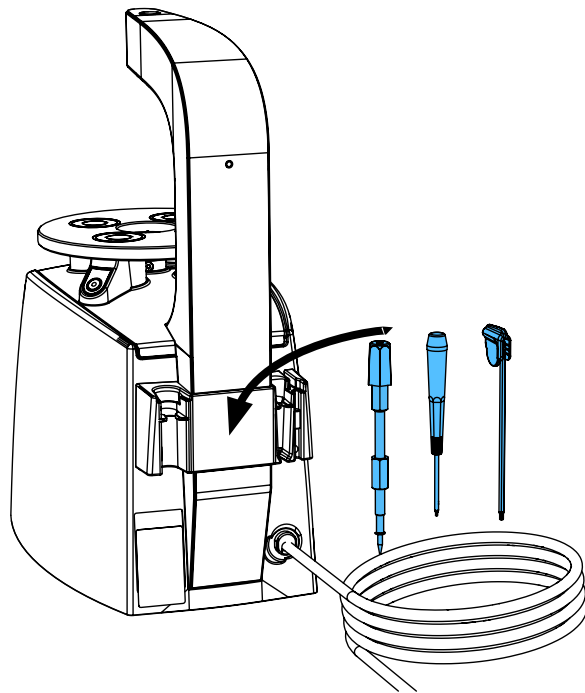
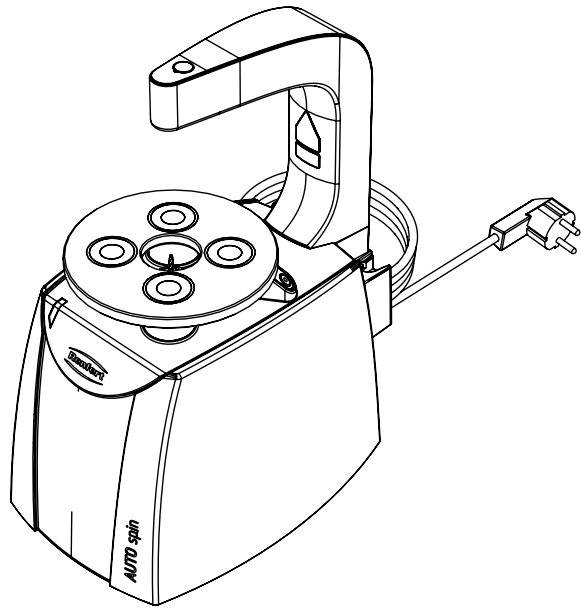



making work easy

Test

Schutzleiterprüfung • Protective conductor test • Vérification du conducteur de protection • Verifica del conduttore di protezione • Comprobación del conductor de protección • Проверка защитного провода

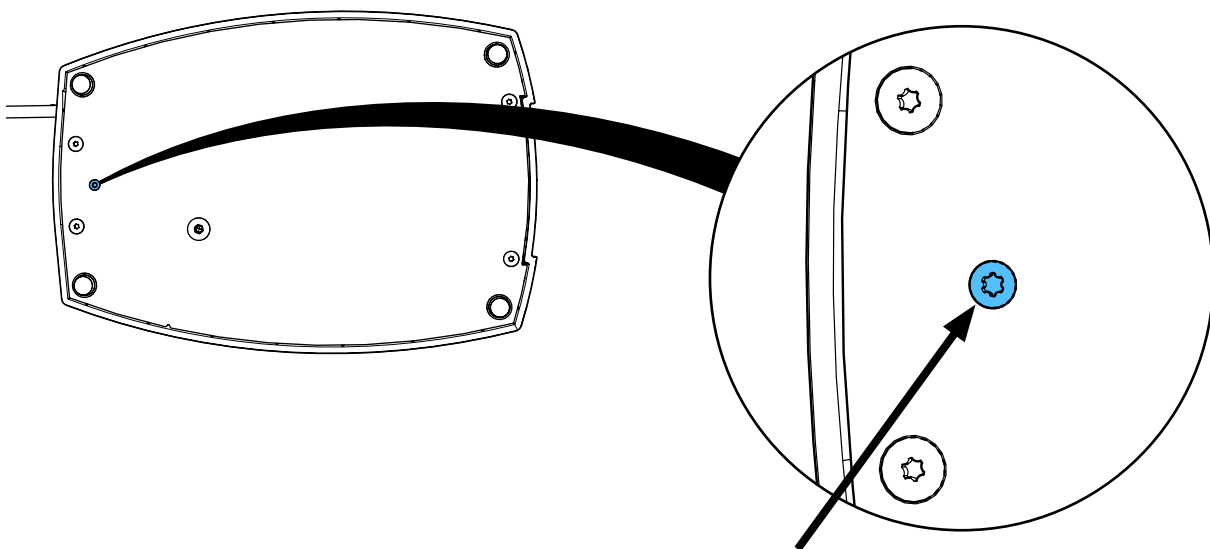
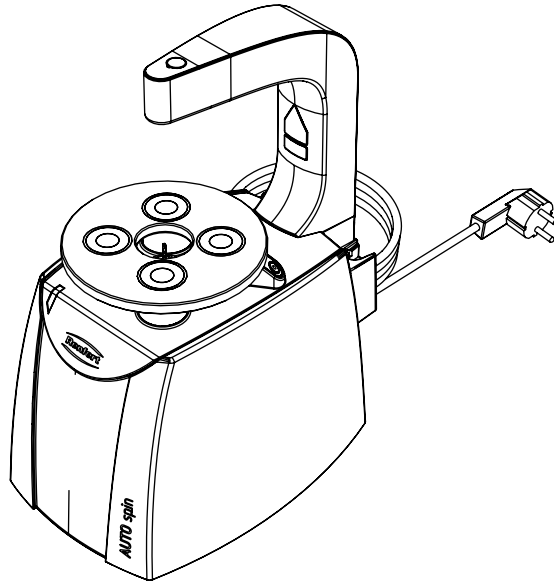

Messpunkt für Schutzleiterprüfung • Measuring point for protective conductor testing • Point de mesure pour le test du conducteur de protection • Punto di misurazione per la verifica del conduttore di protezione • Punto de medición para la comprobación del conductor de protección • Точка замера для проверки защитного провода

**Hochaktuell und ausführlich auf ...
Up to date and in detail at ...
Actualisé et détaillé sous ...
Aggiornato e dettagliato su ...
La máxima actualidad y detalle en ...
Актуально и подробно на ...**

www.renfert.com

Renfert GmbH • Untere Gießwiesen 2 • 78247 Hilzingen/Germany
Tel.: +49 7731 82 08-0 • Fax: +49 7731 82 08-70
www.renfert.com • info@renfert.com

Renfert USA • 3718 Illinois Avenue • St. Charles IL 60174/USA
Tel.: +1 6307 62 18 03 • Fax: +1 6307 62 97 87
www.renfert.com • info@renfertusa.com
USA: Free call 800 336 7422