

16.

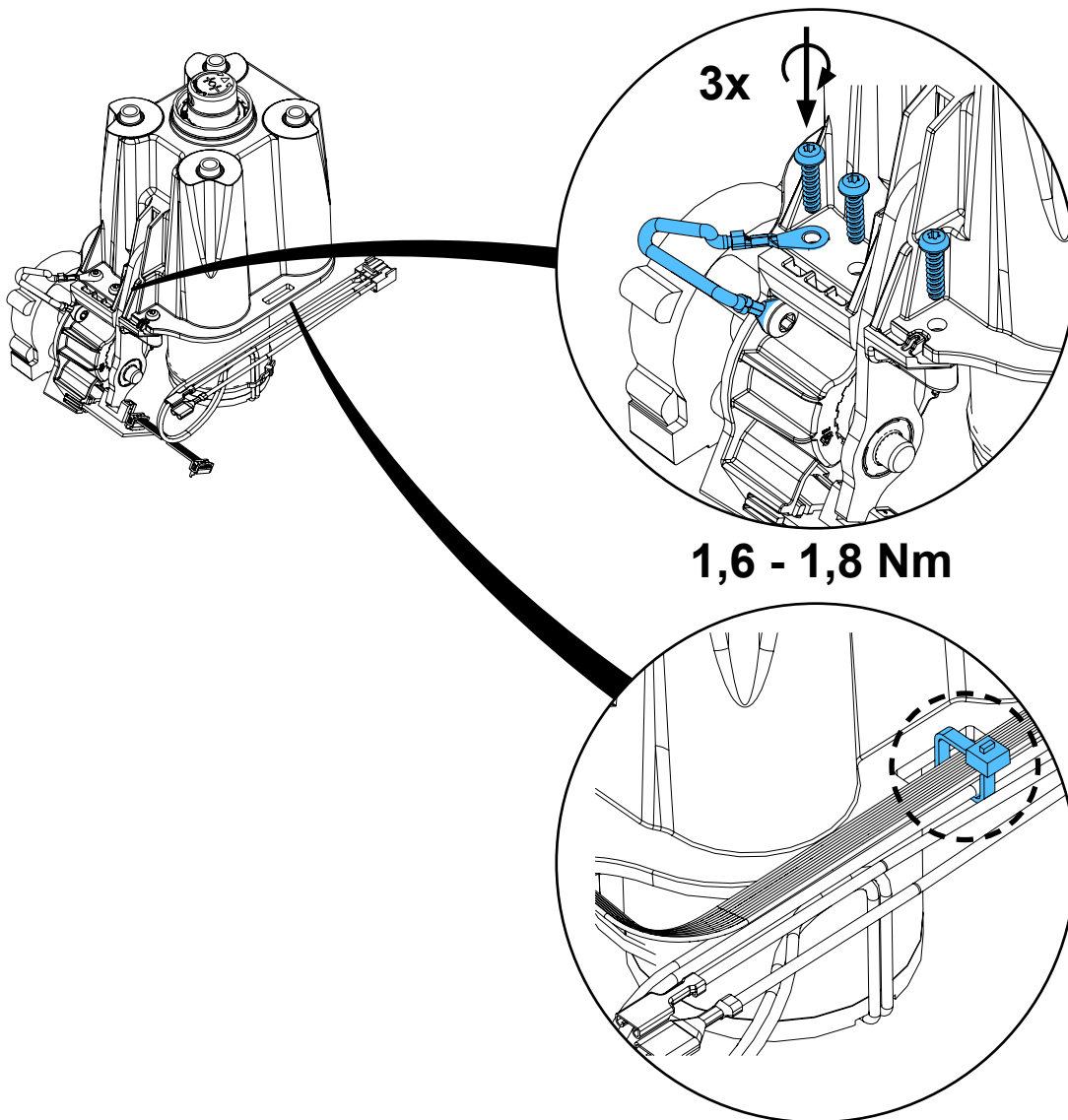

17.

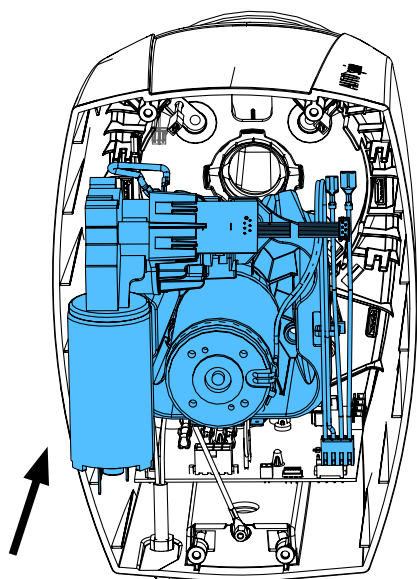

18.

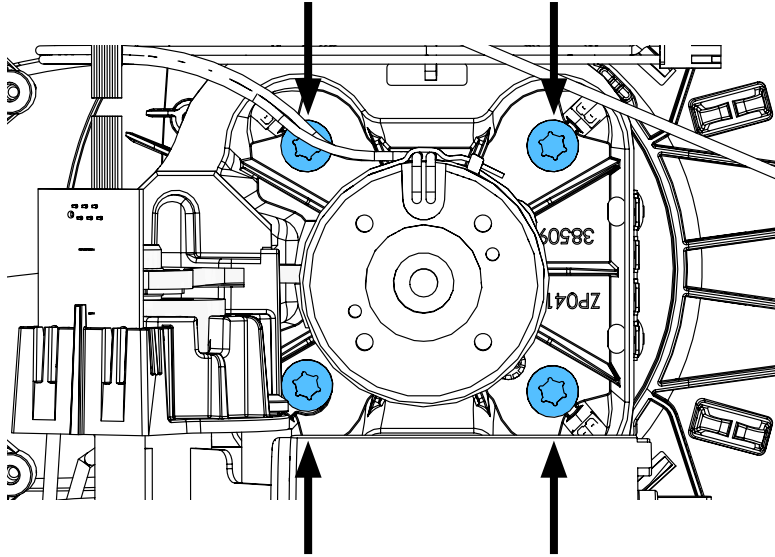
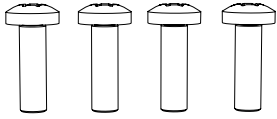

4x
2,5 - 3,0 Nm

19.

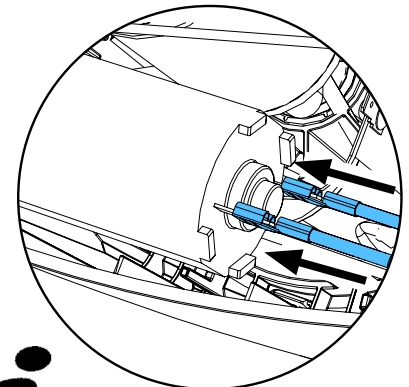
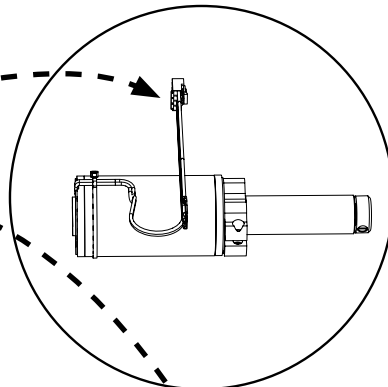
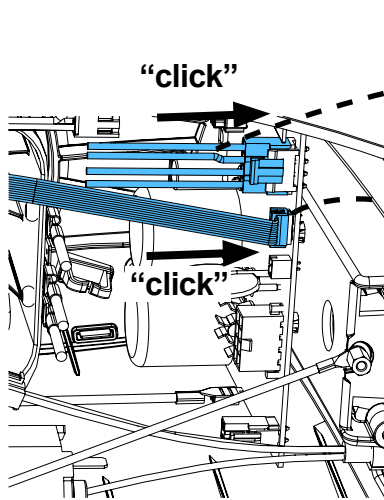

i

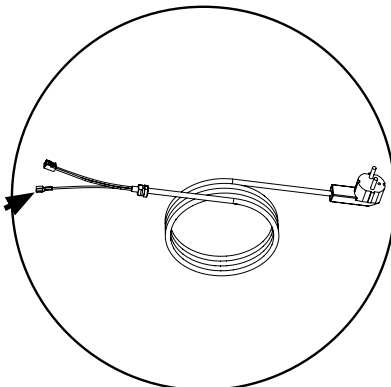
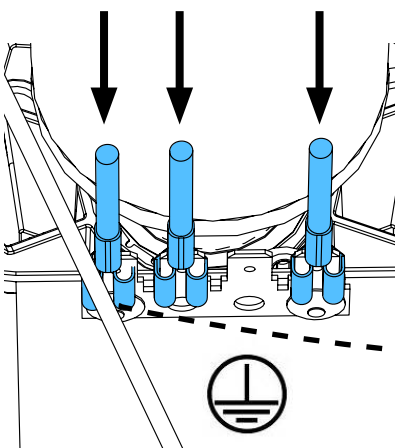
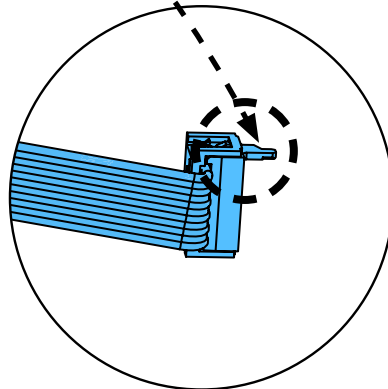

20.

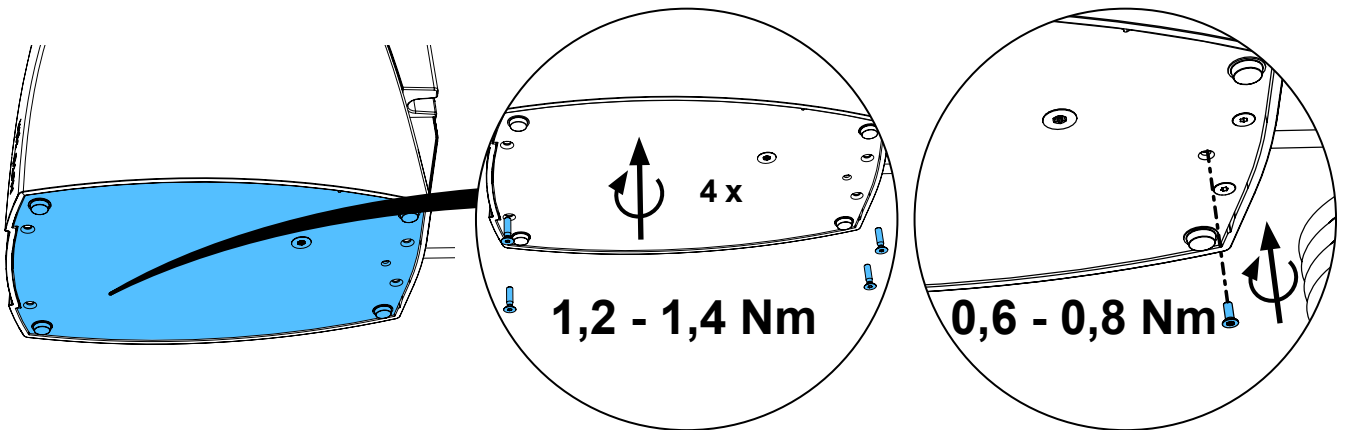
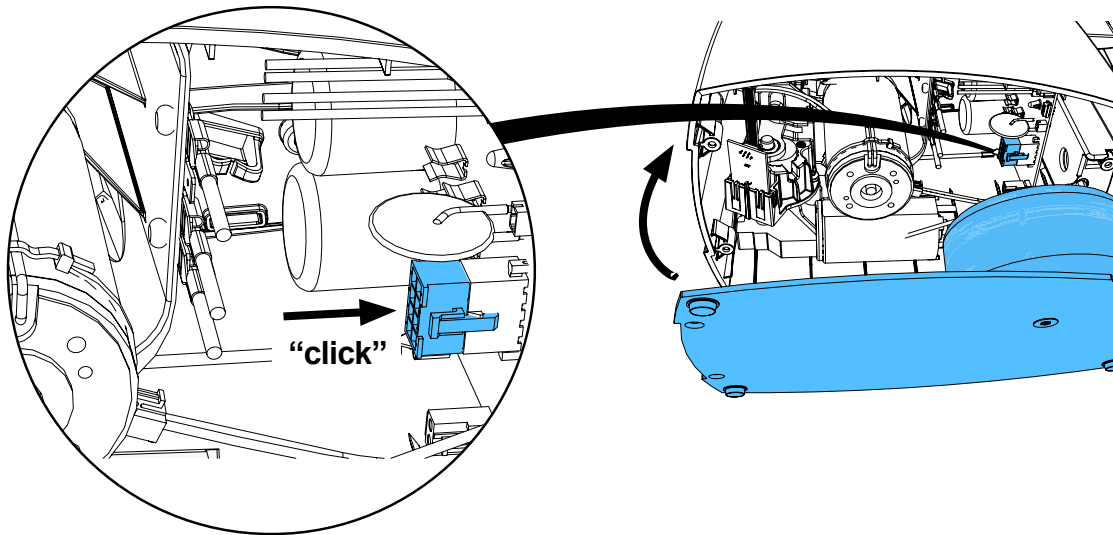

21.

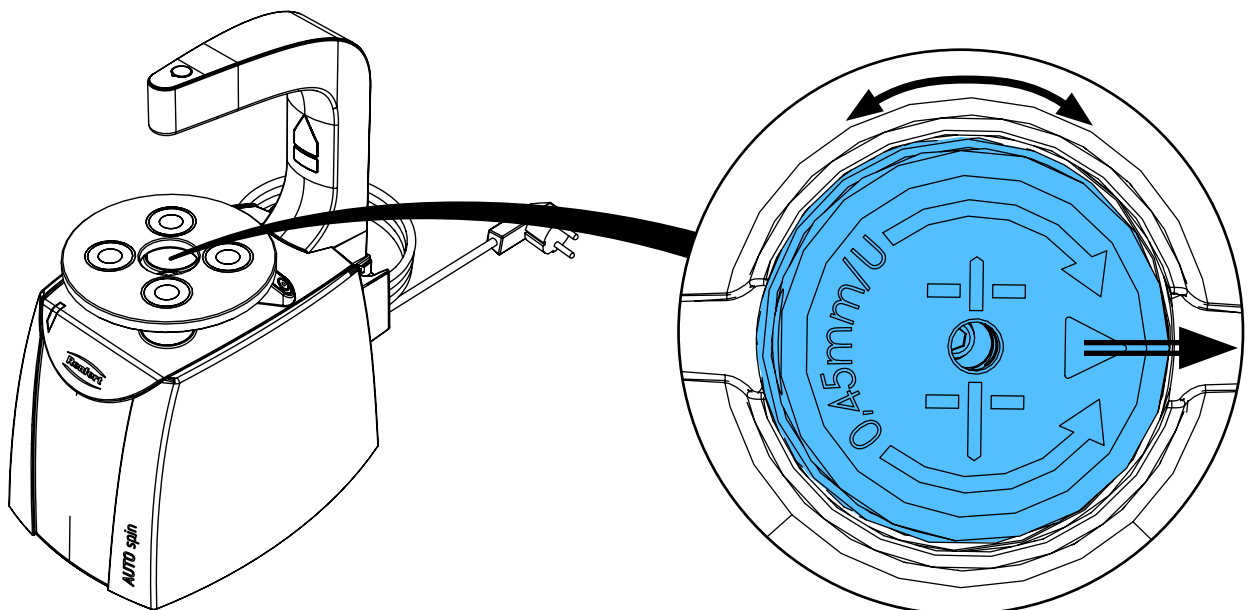

22.

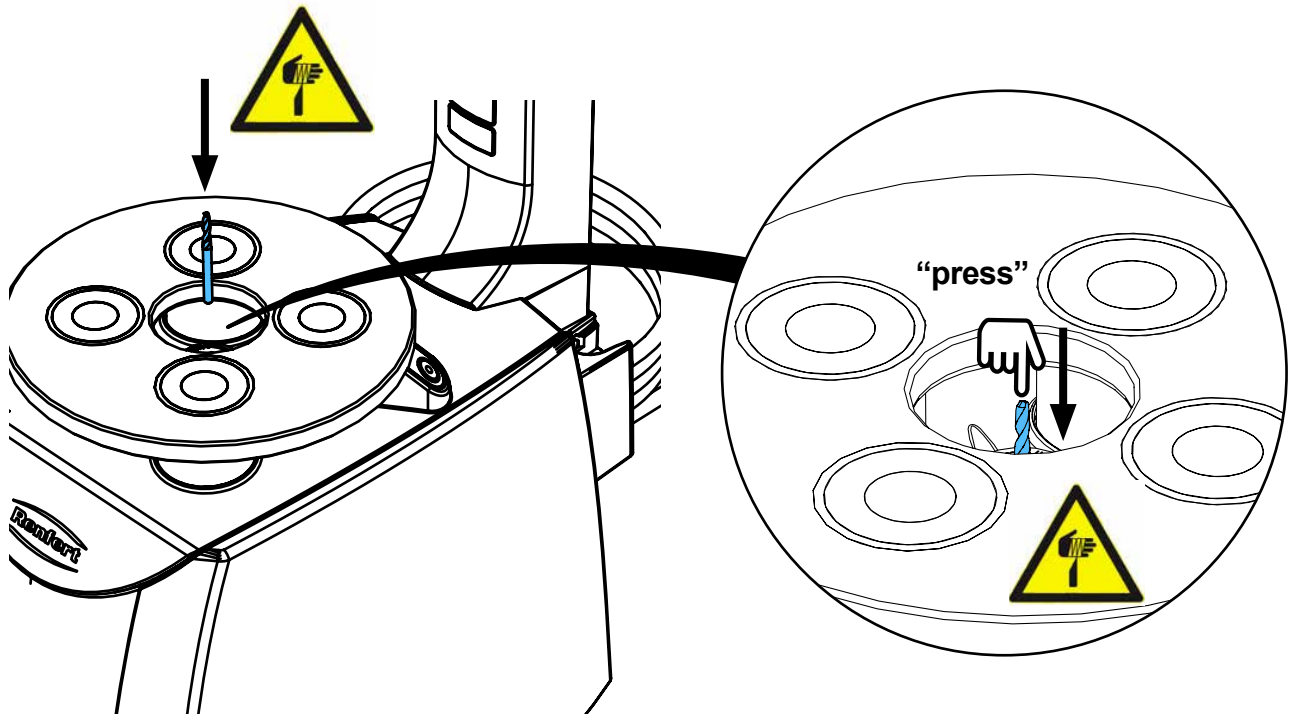

23.

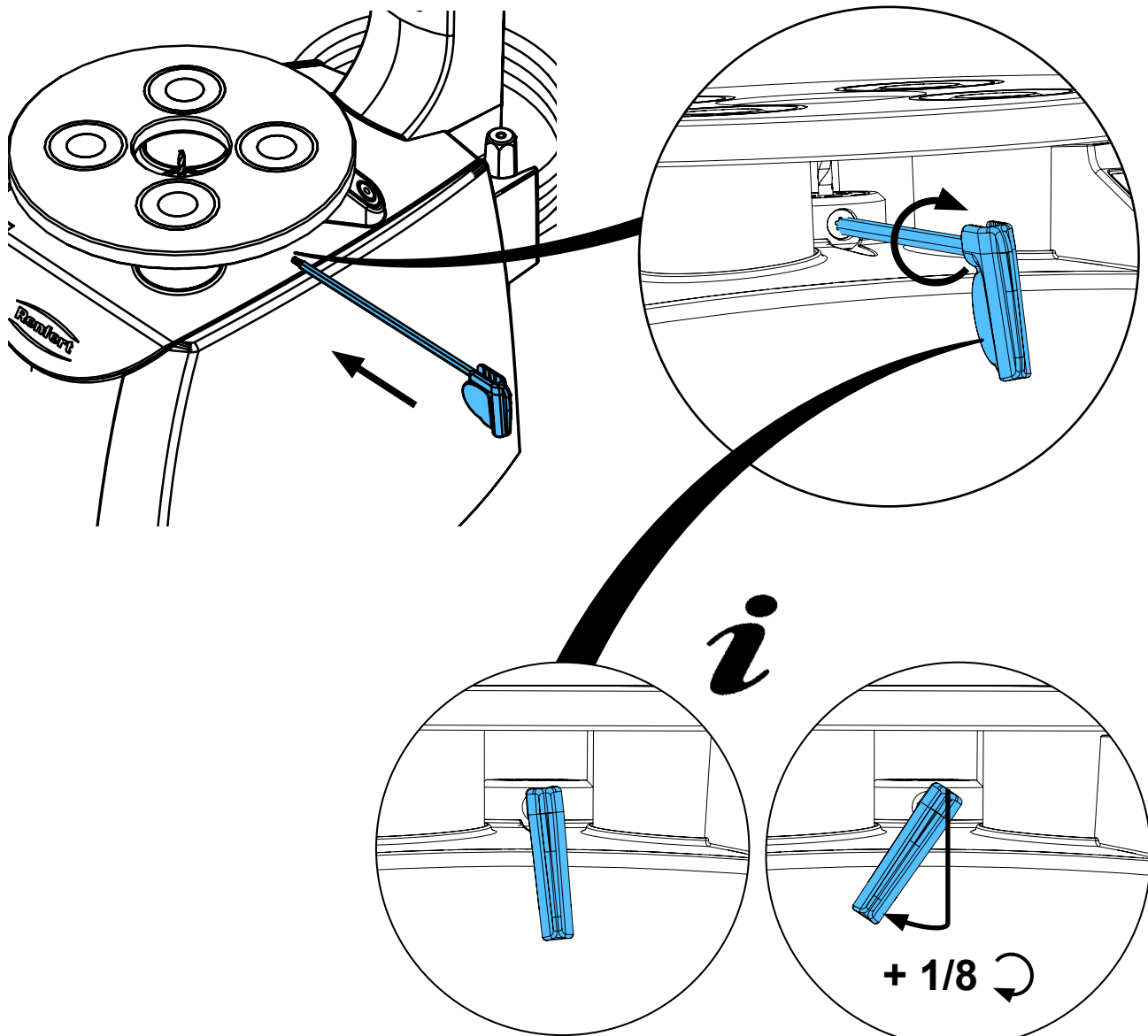

i

24.



Schutzleiterprüfung durchführen: siehe am Ende der „Service Instructions“.

Performing the protective conductor test: see at the end of the “Service instructions”.

Pour vérifier le conducteur de protection: voir à la fin des “Instructions de service”.

Per la verifica del conduttore di terra: vedere alla fine delle “Istruzioni di servizio”.

Realizar la prueba del conductor de protección: véase al final de las “Instrucciones de servicio”.

Выполнить проверку защитного провода: см. в конце „Инструкции по обслуживанию“.



25.

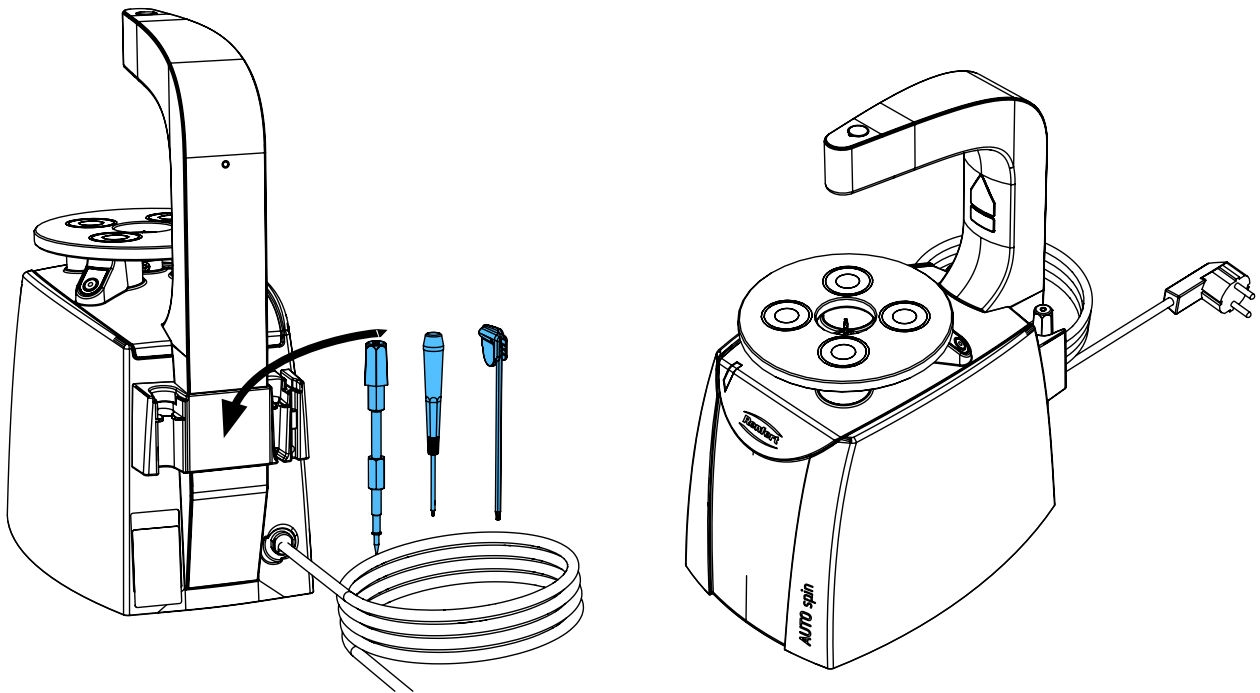



making work easy

90003 7009

Hub-Getriebemotor • Gear / lifting motor • Motoréducteur d'élévation • Motoriduttore di sollevamento • Motorreductor elevador • Подъемный мотор-редуктор

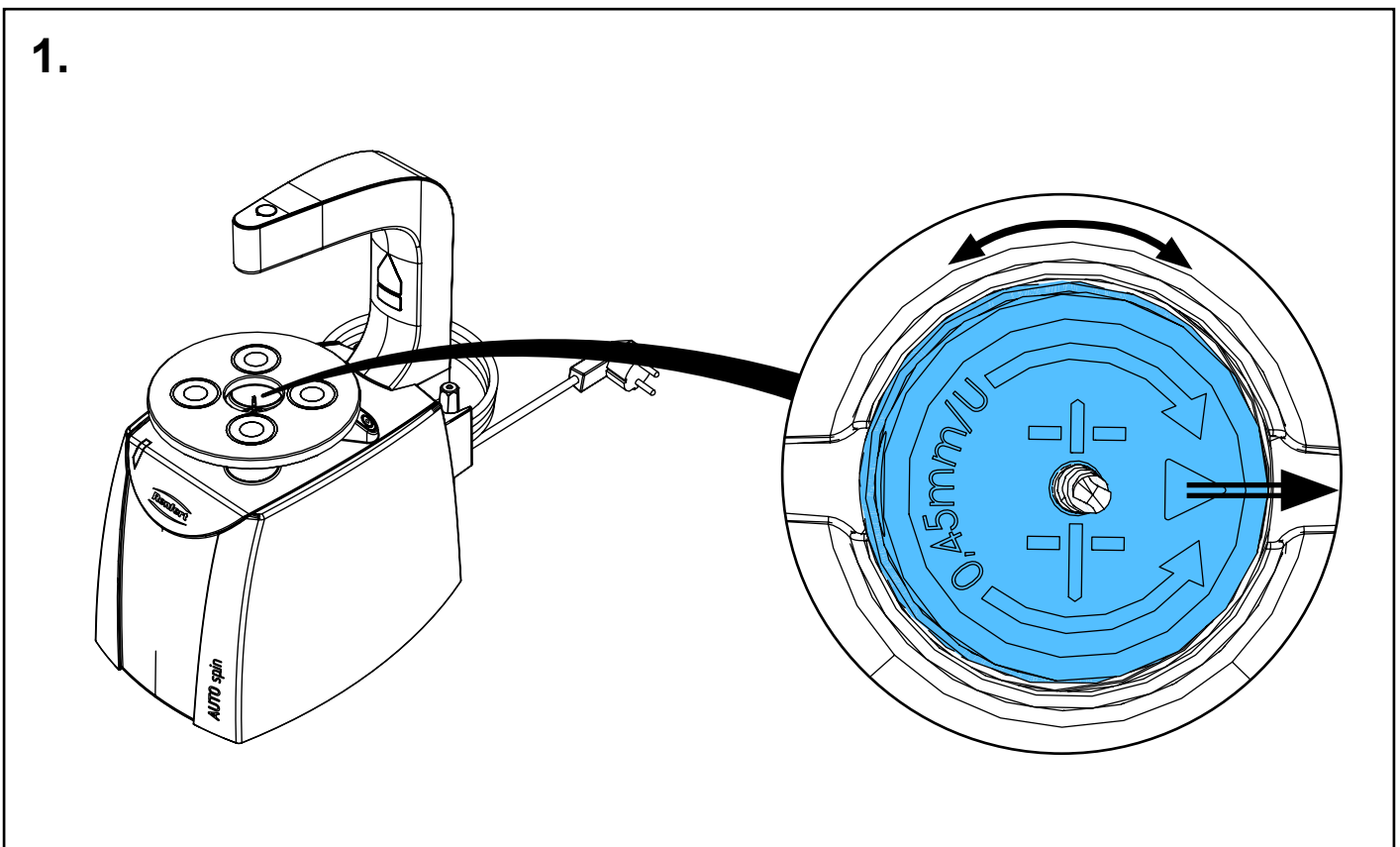
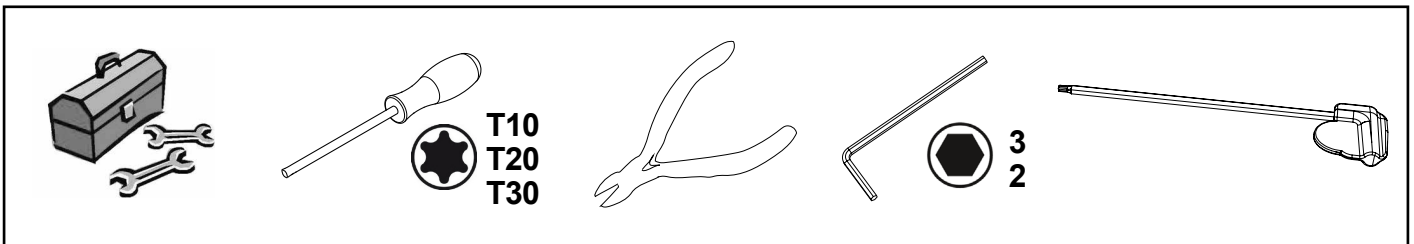
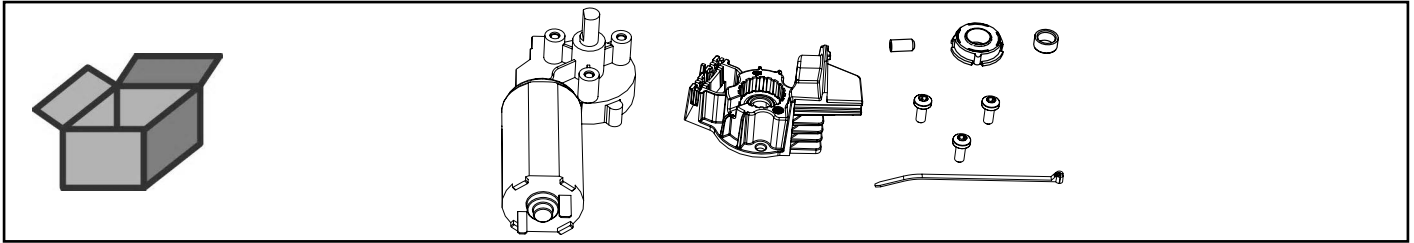

2.

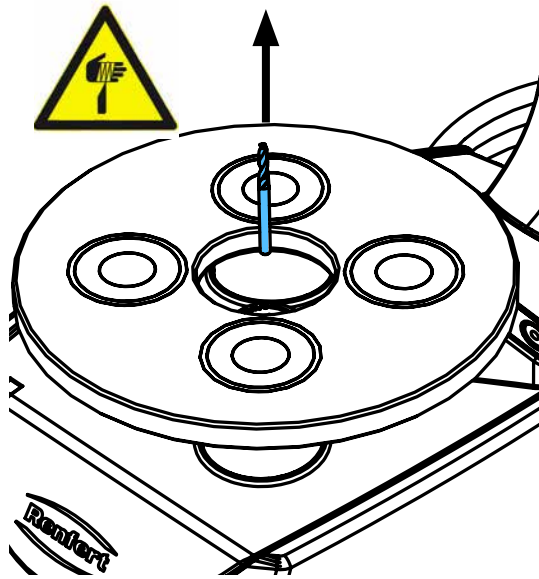
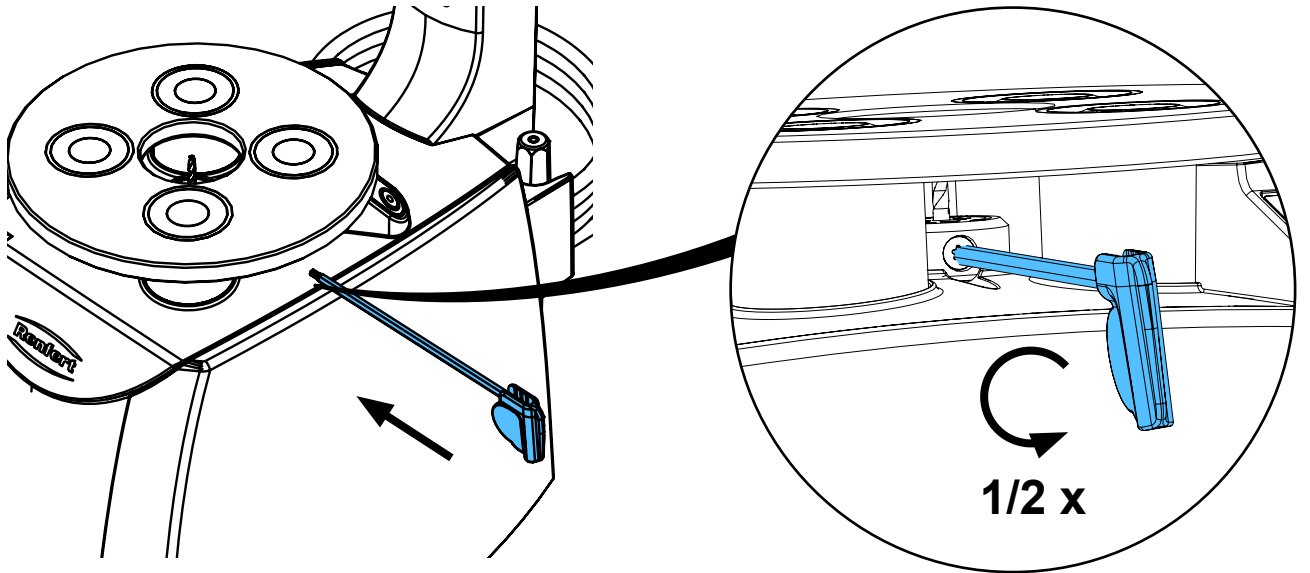

3.

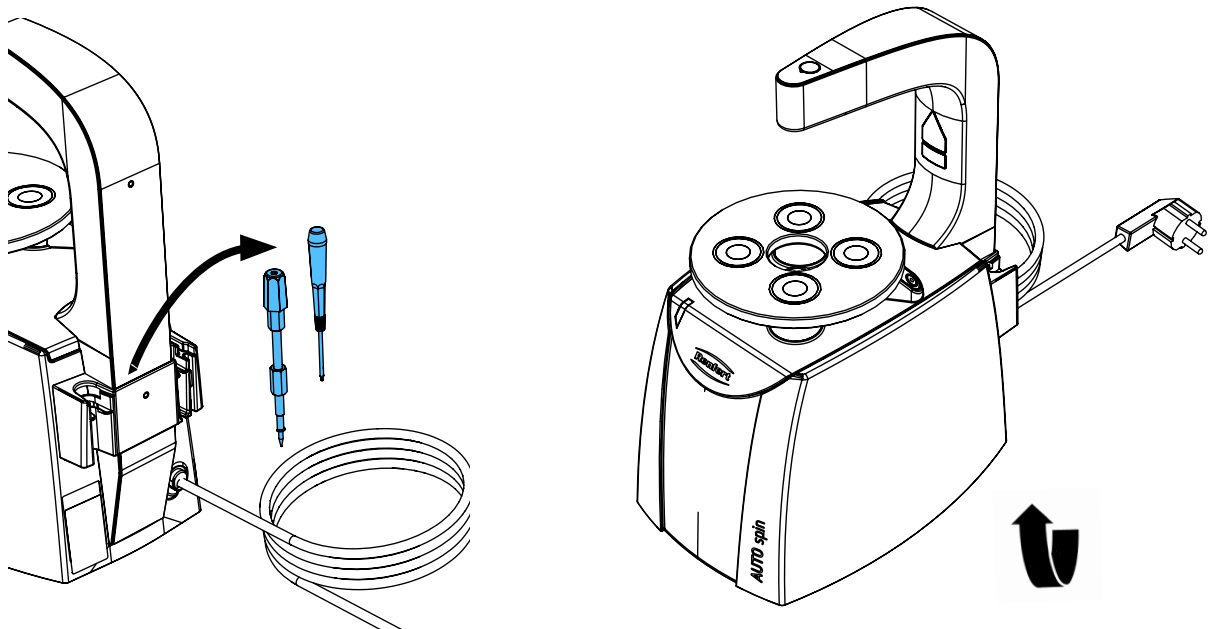

4.

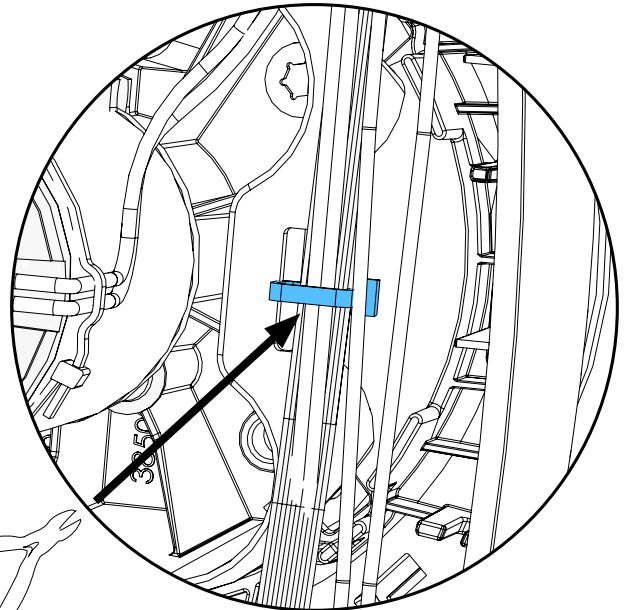
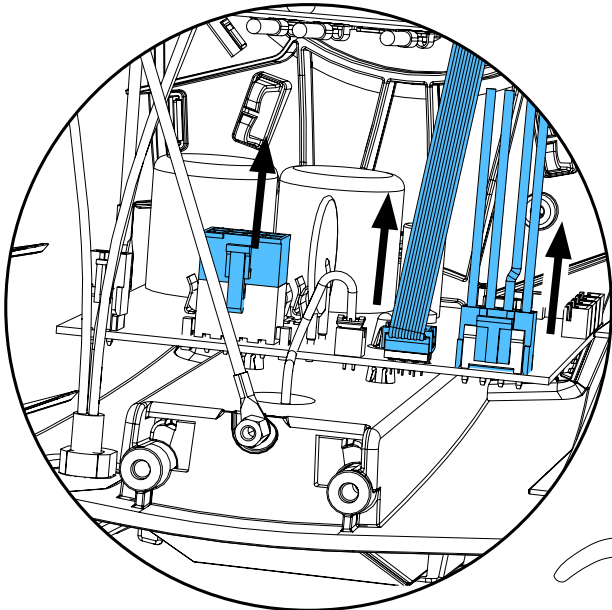
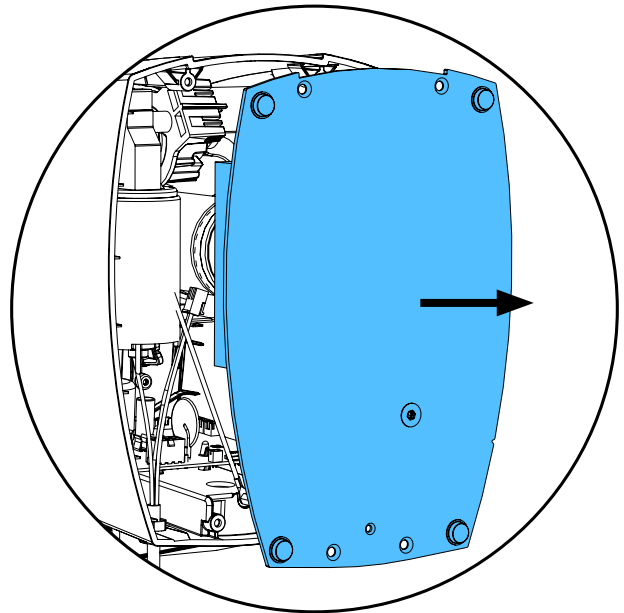
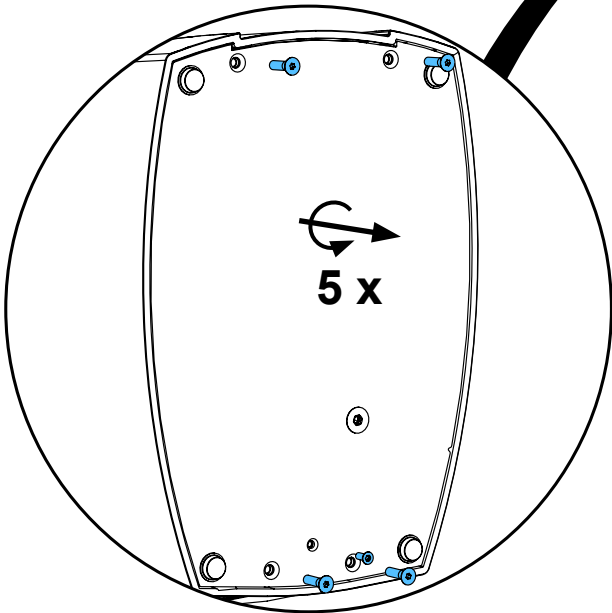
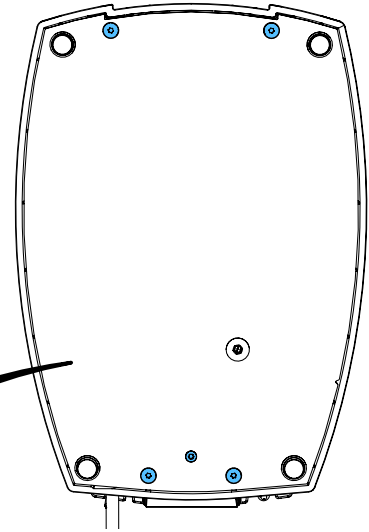
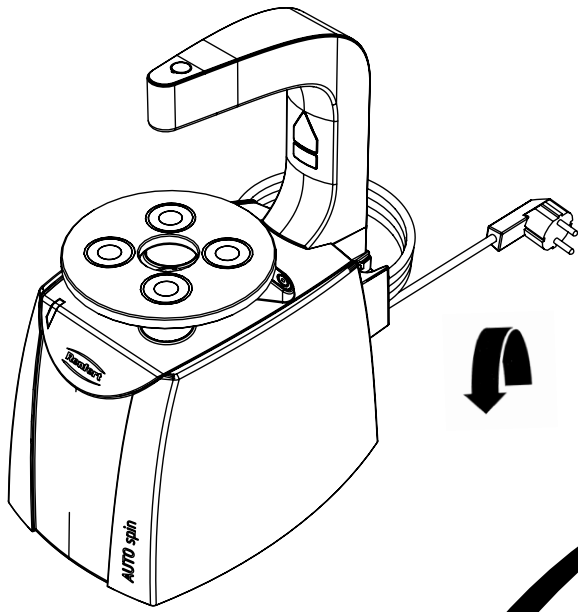

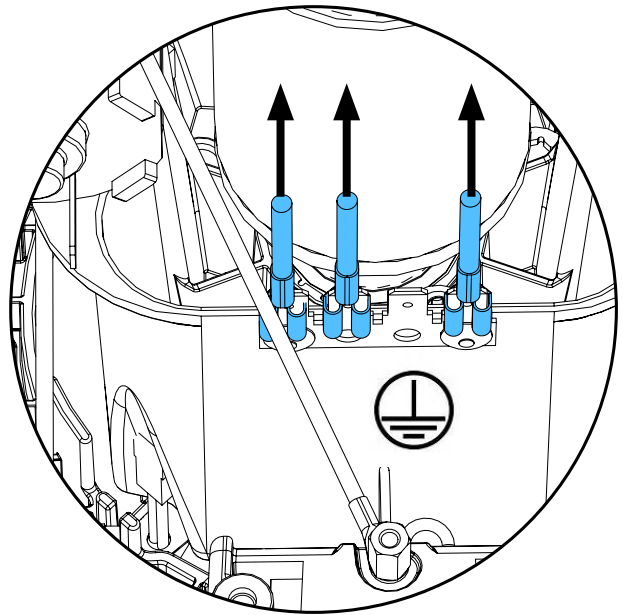
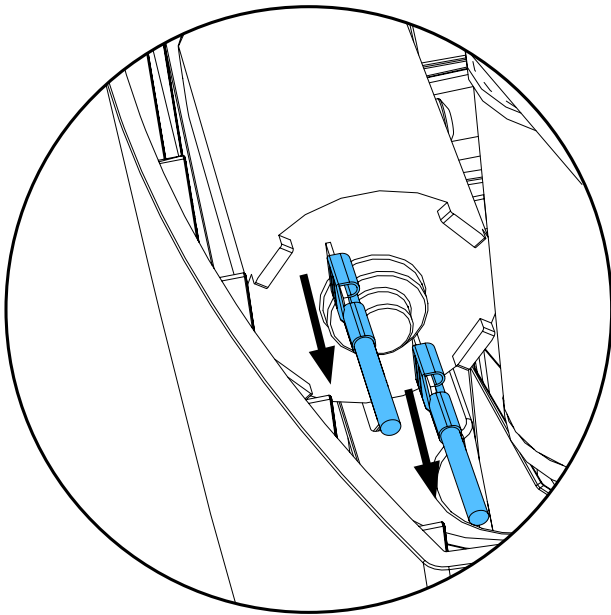

5.

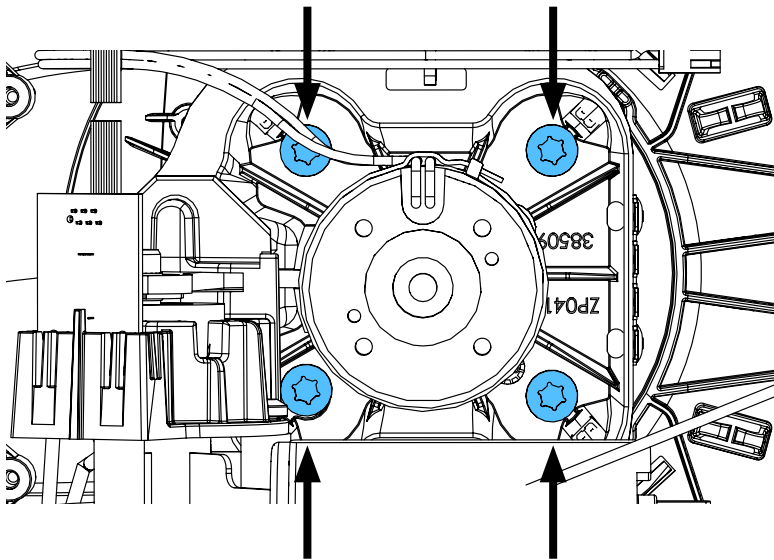

6.

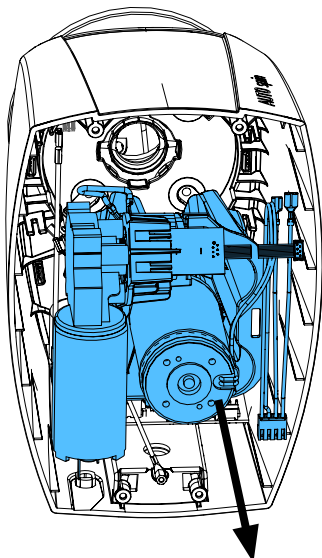

7.

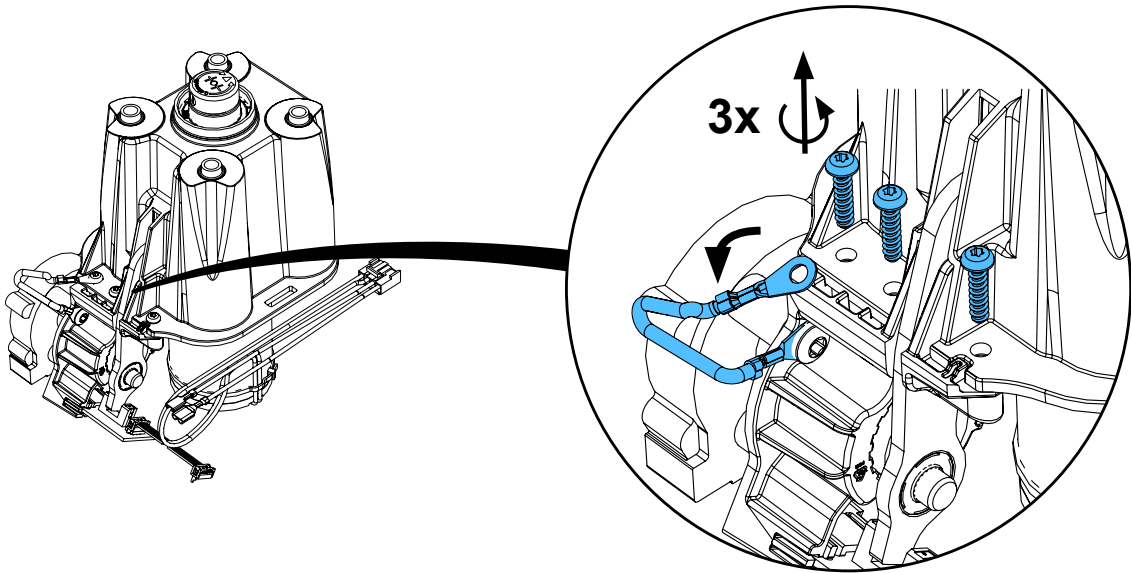

8.

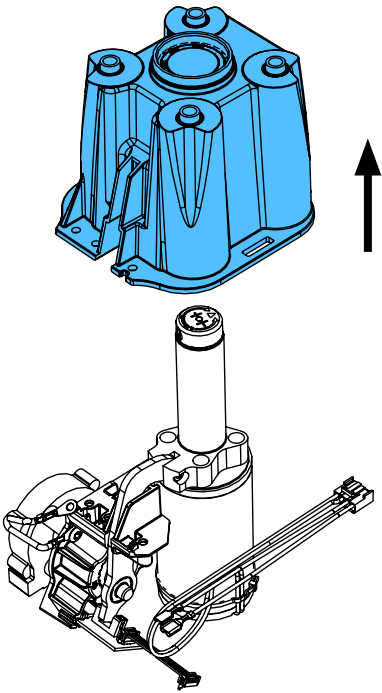

9.

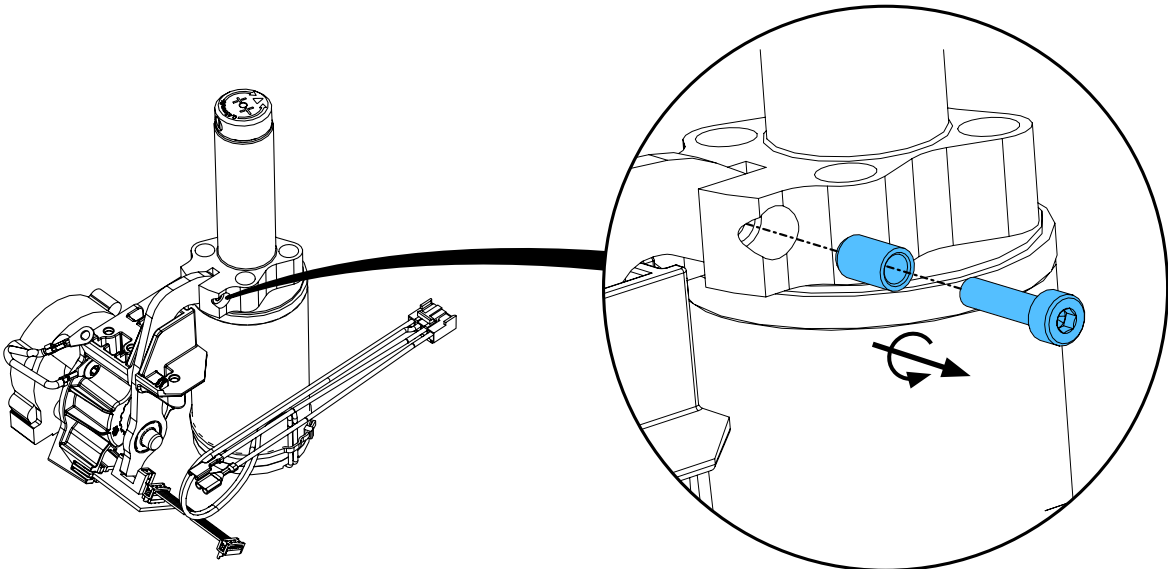

10.

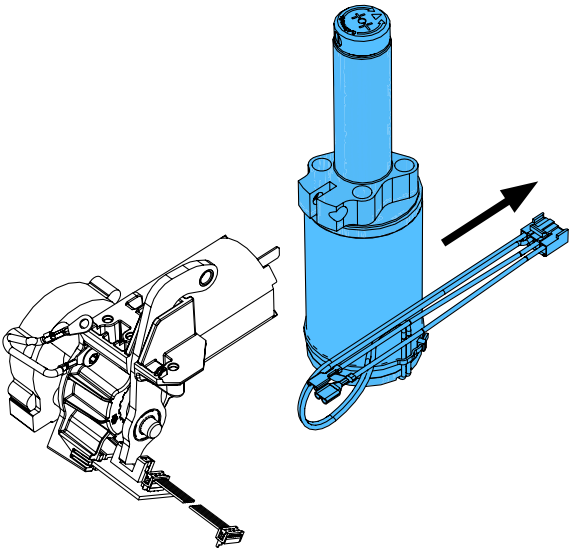

11.

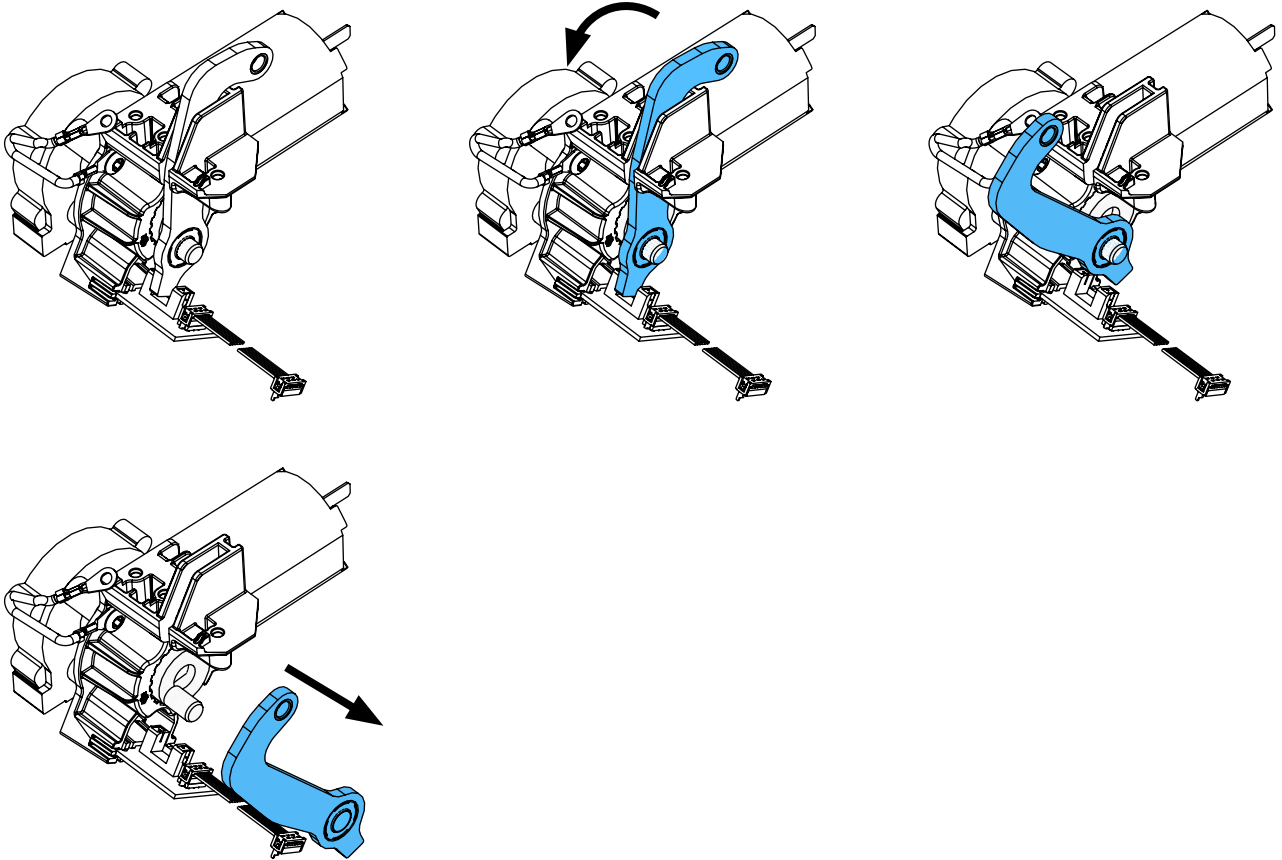

12.

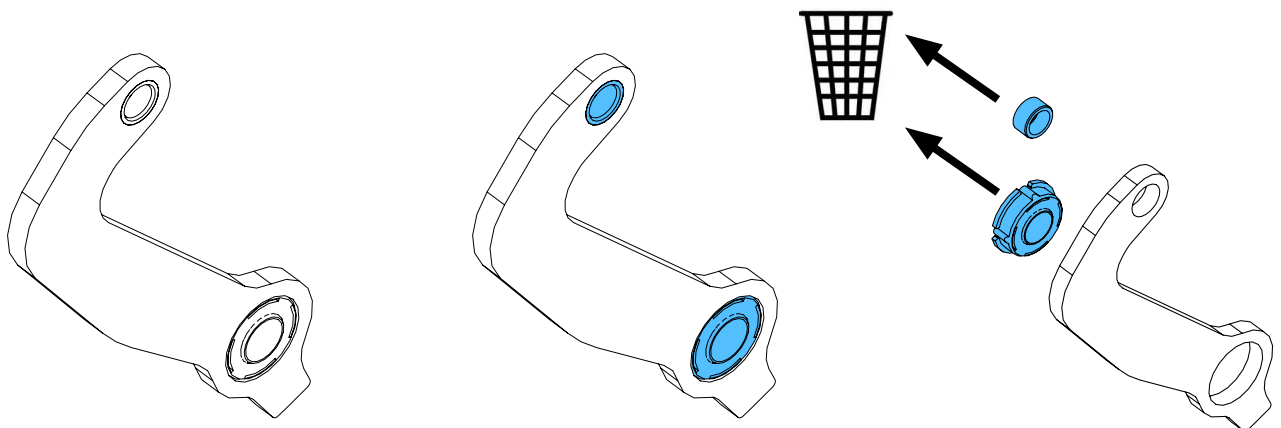

13.

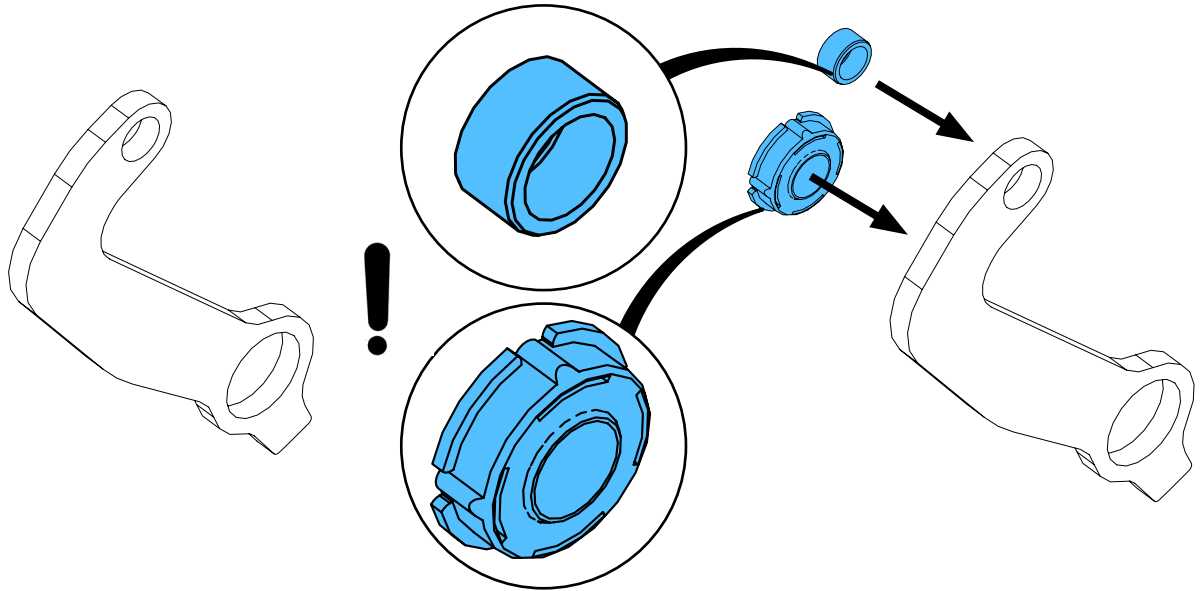

14.

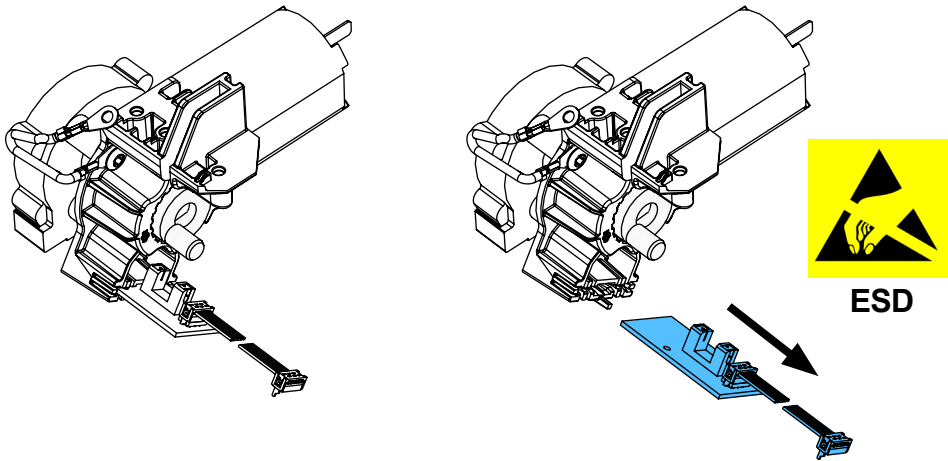

15.

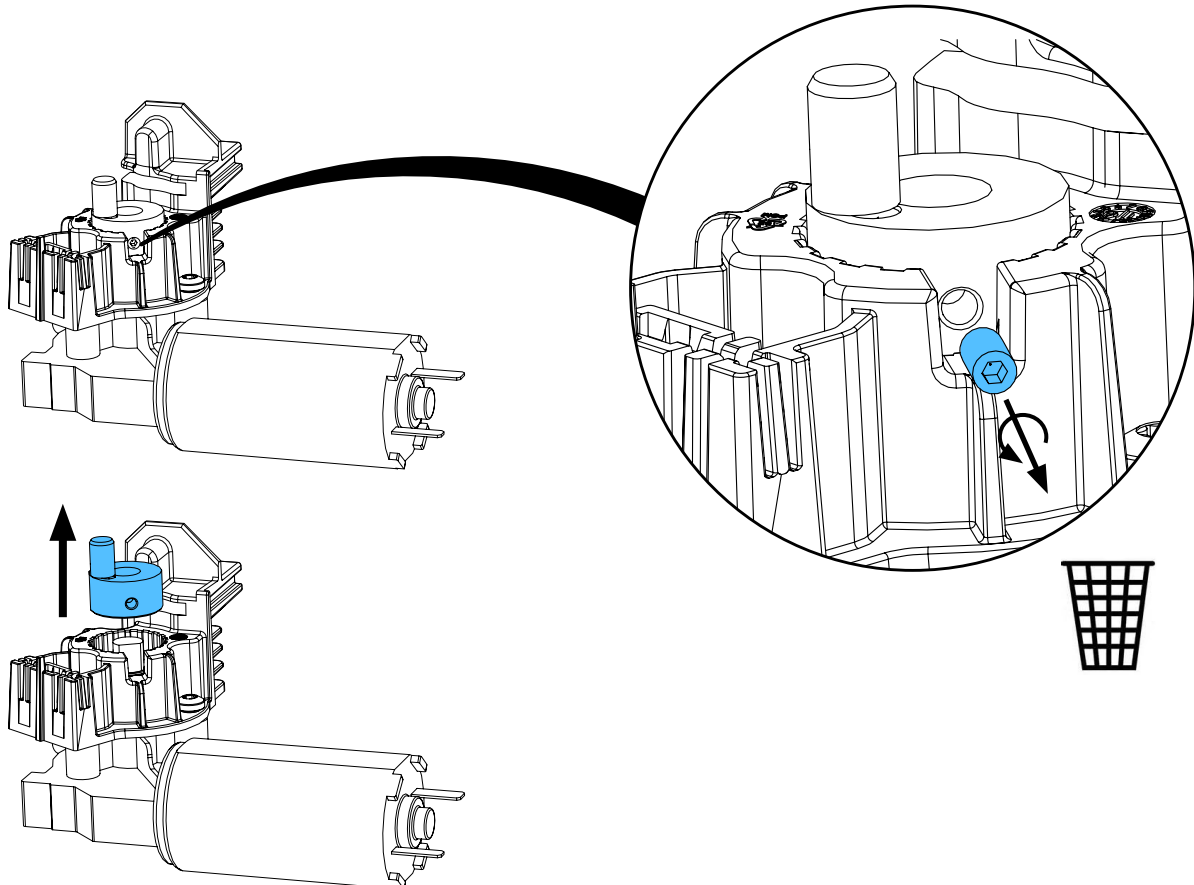

16.

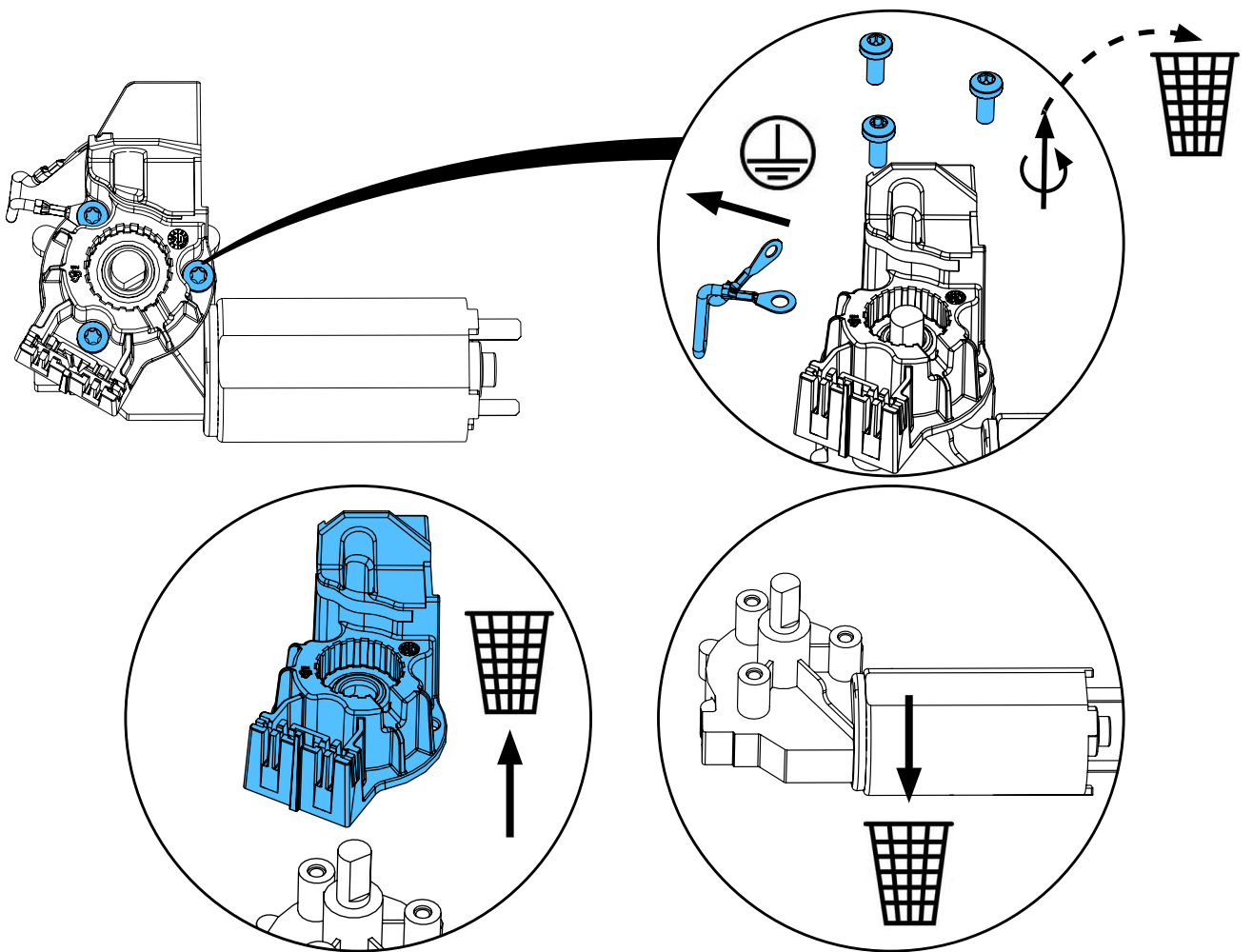

17.

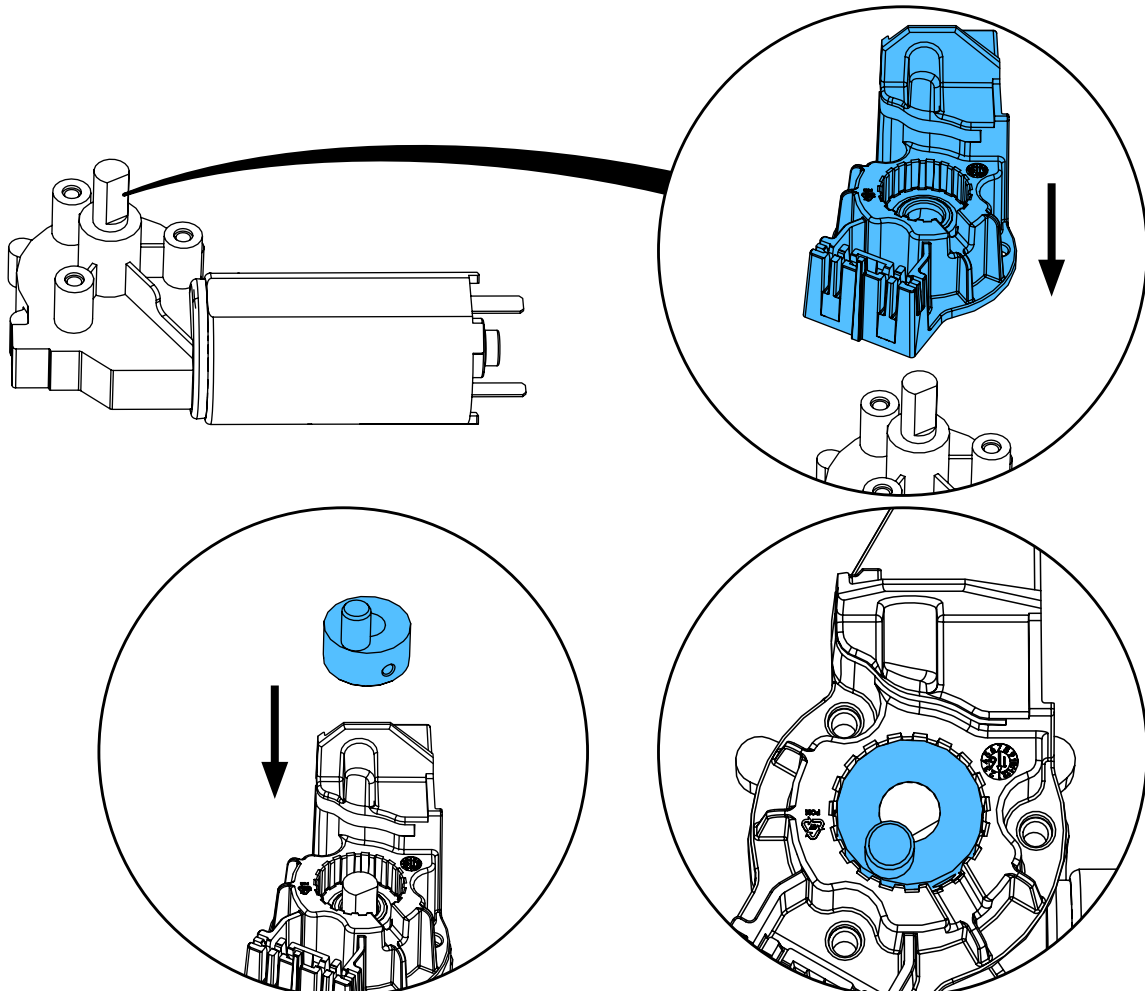

i

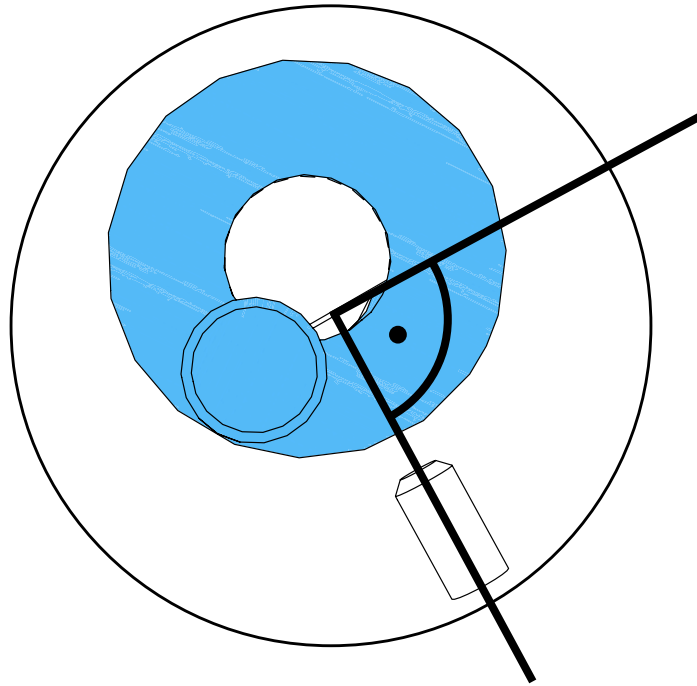

18.

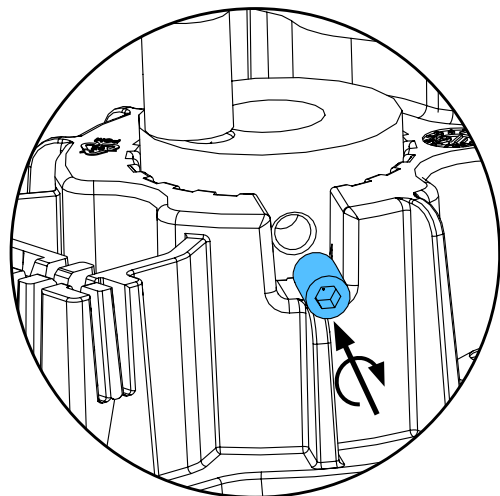
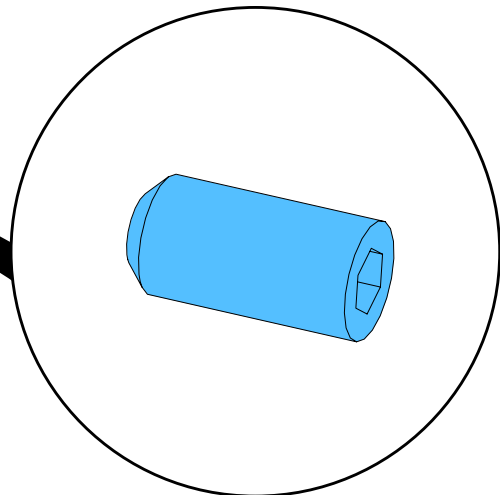
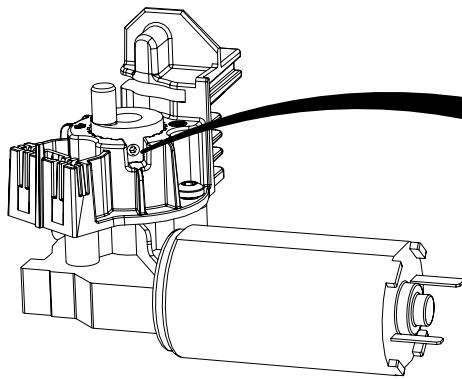

1,4 - 1,6 Nm

19.

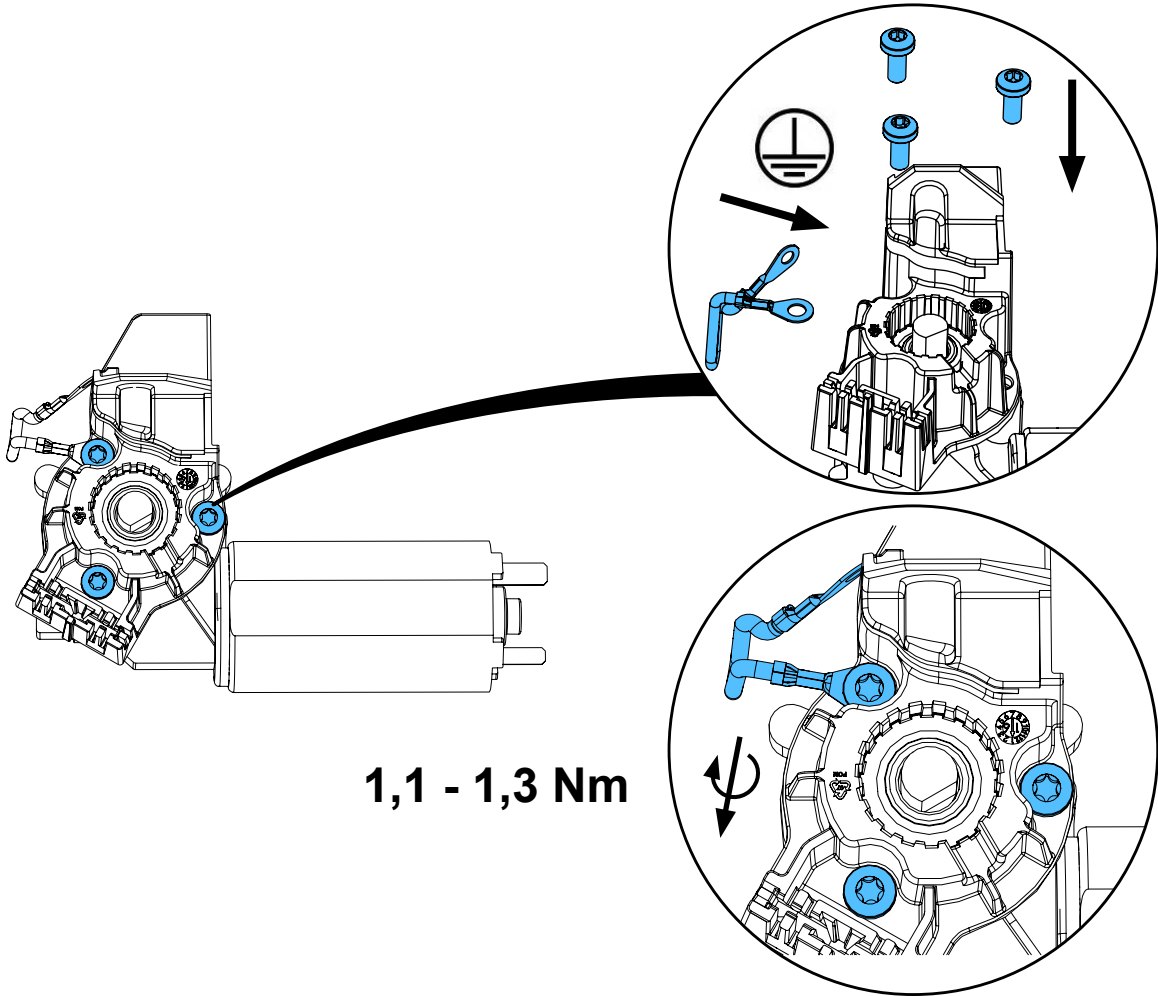

20.

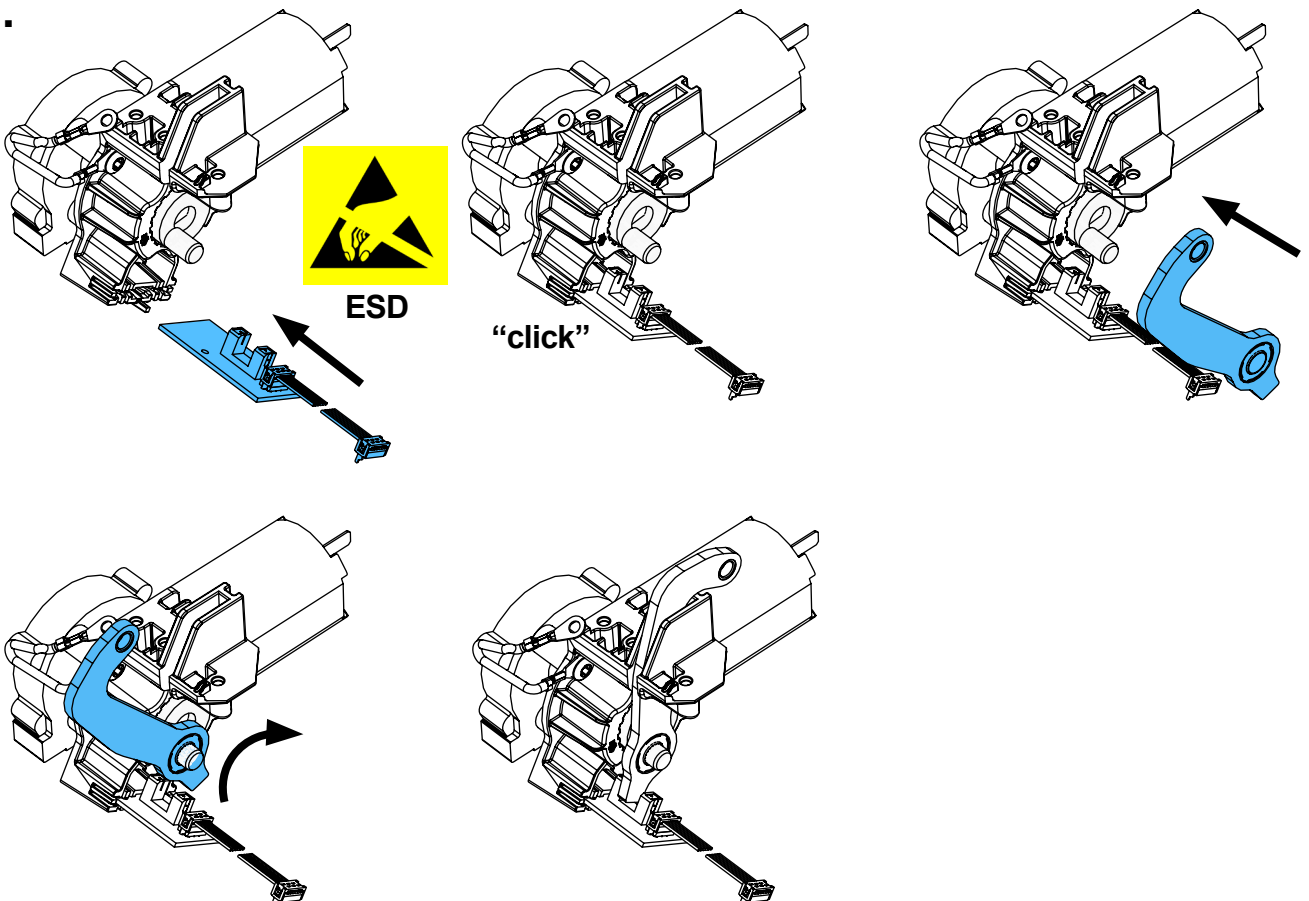

21.

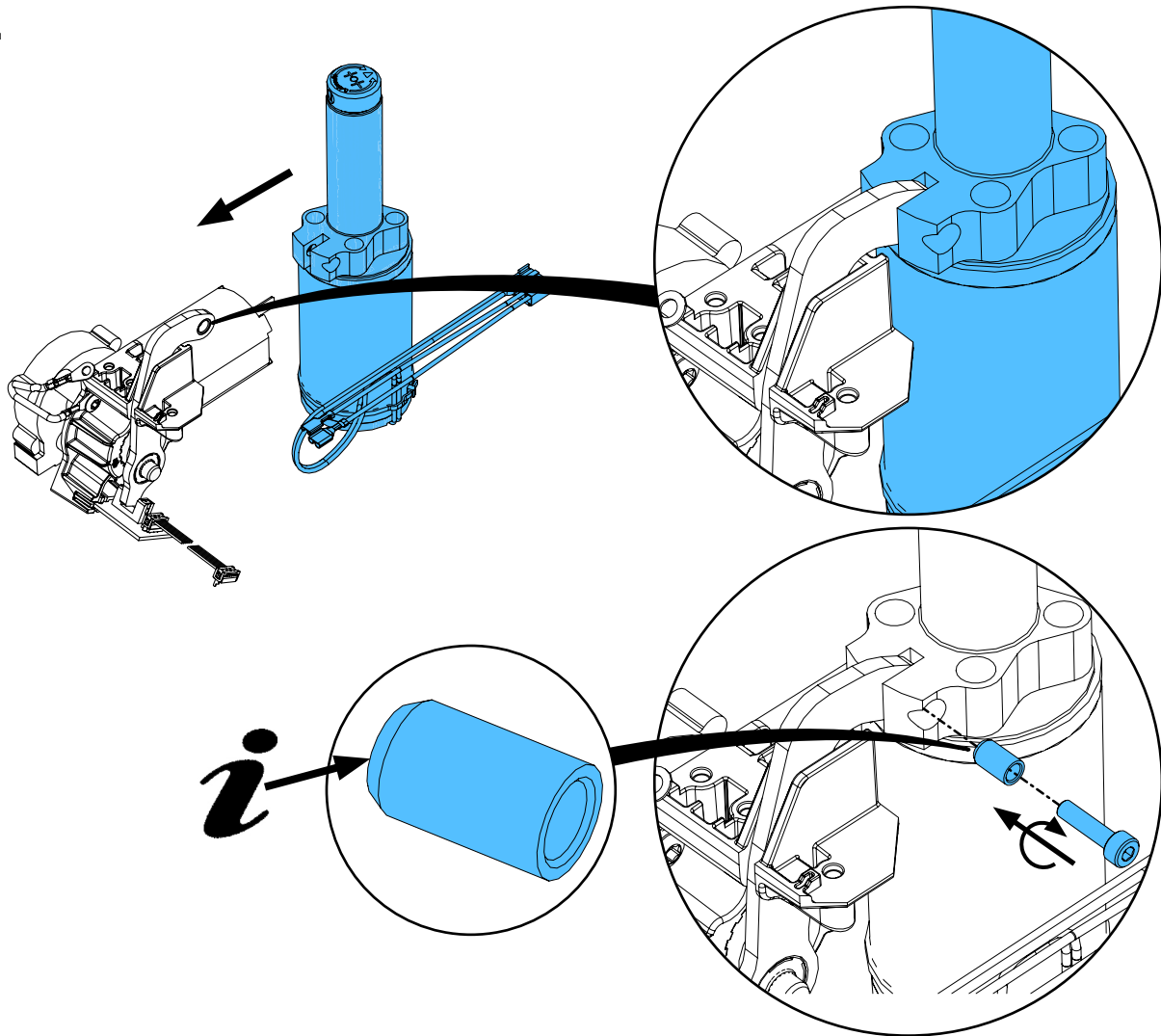

1,4 - 1,6 Nm

22.

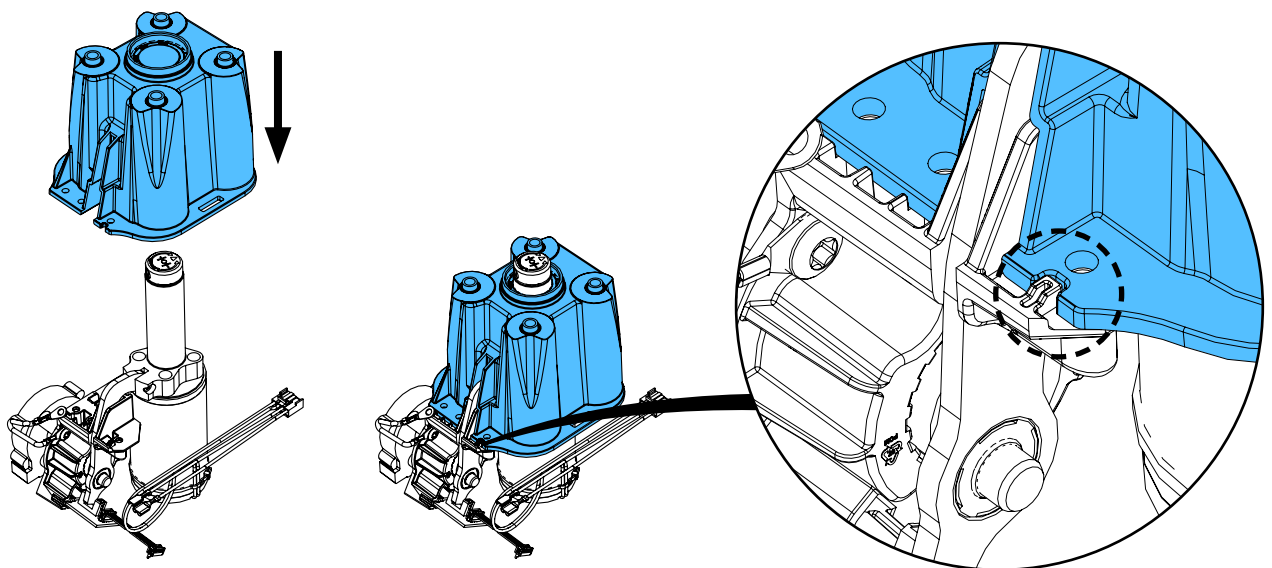

23.

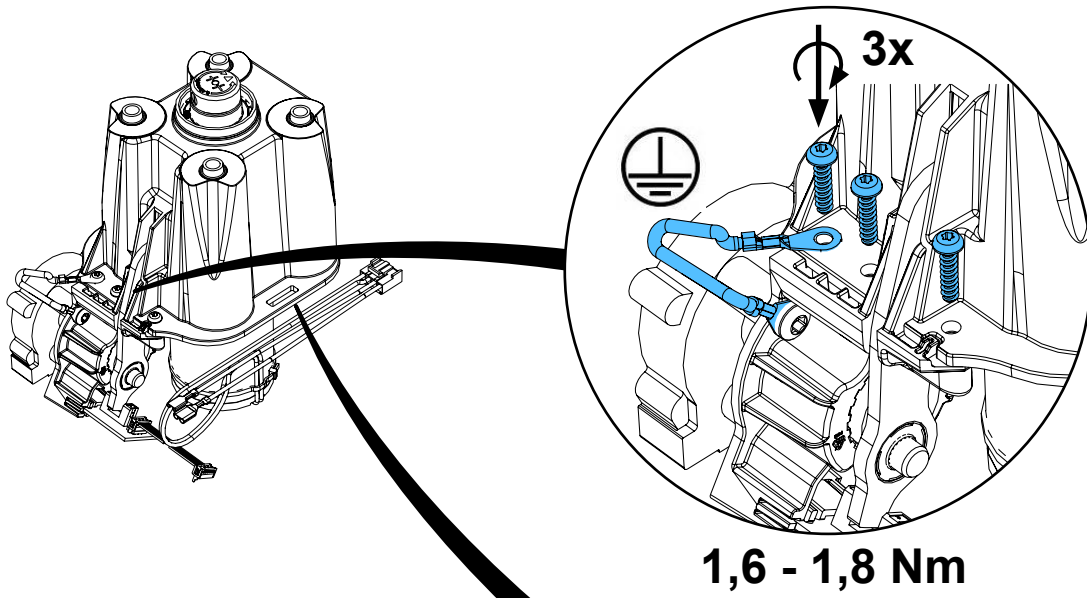

24.

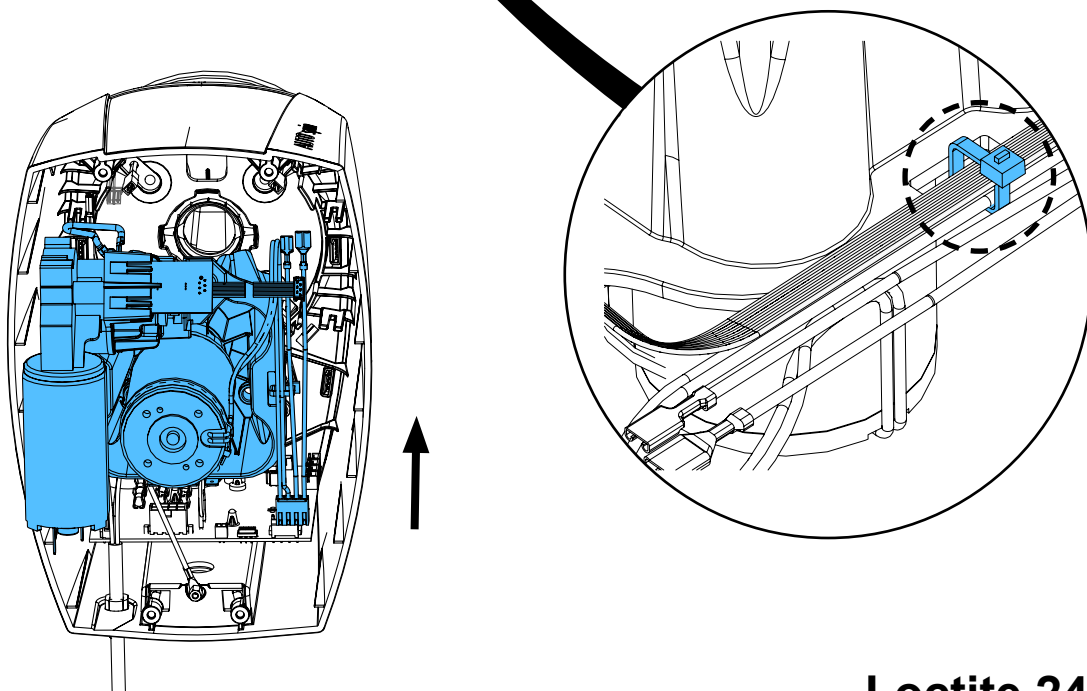

25.

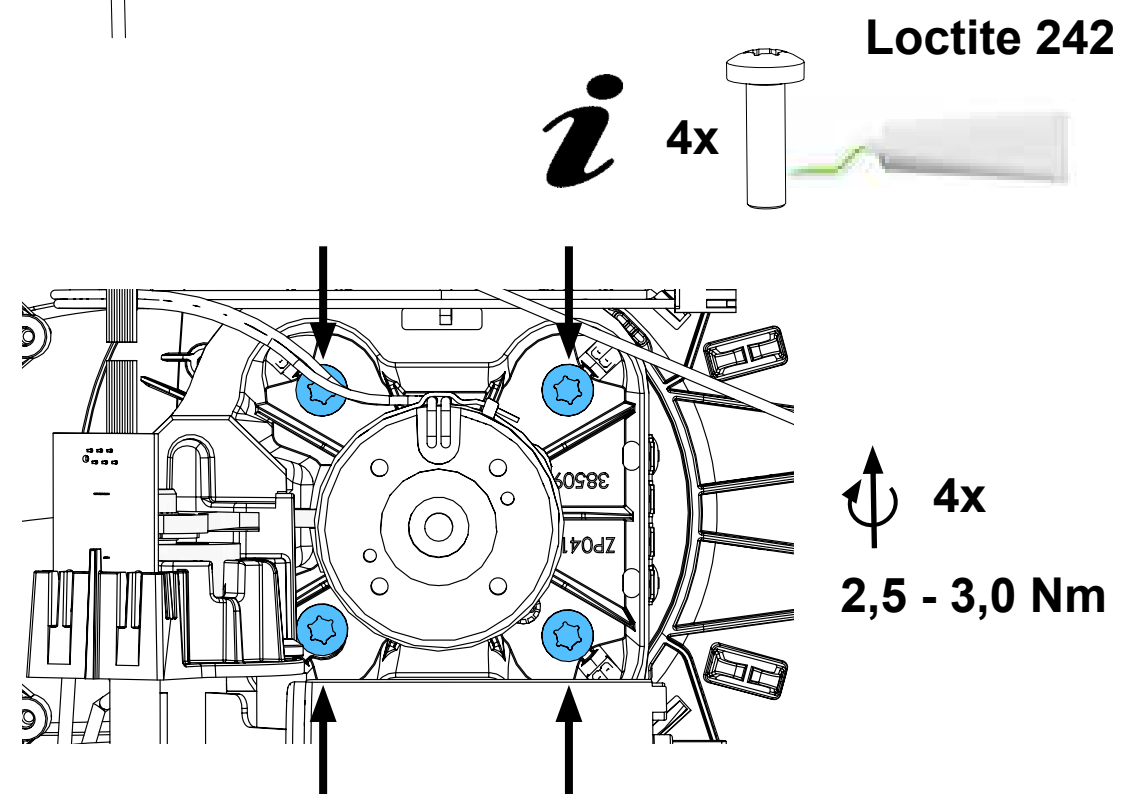

26.

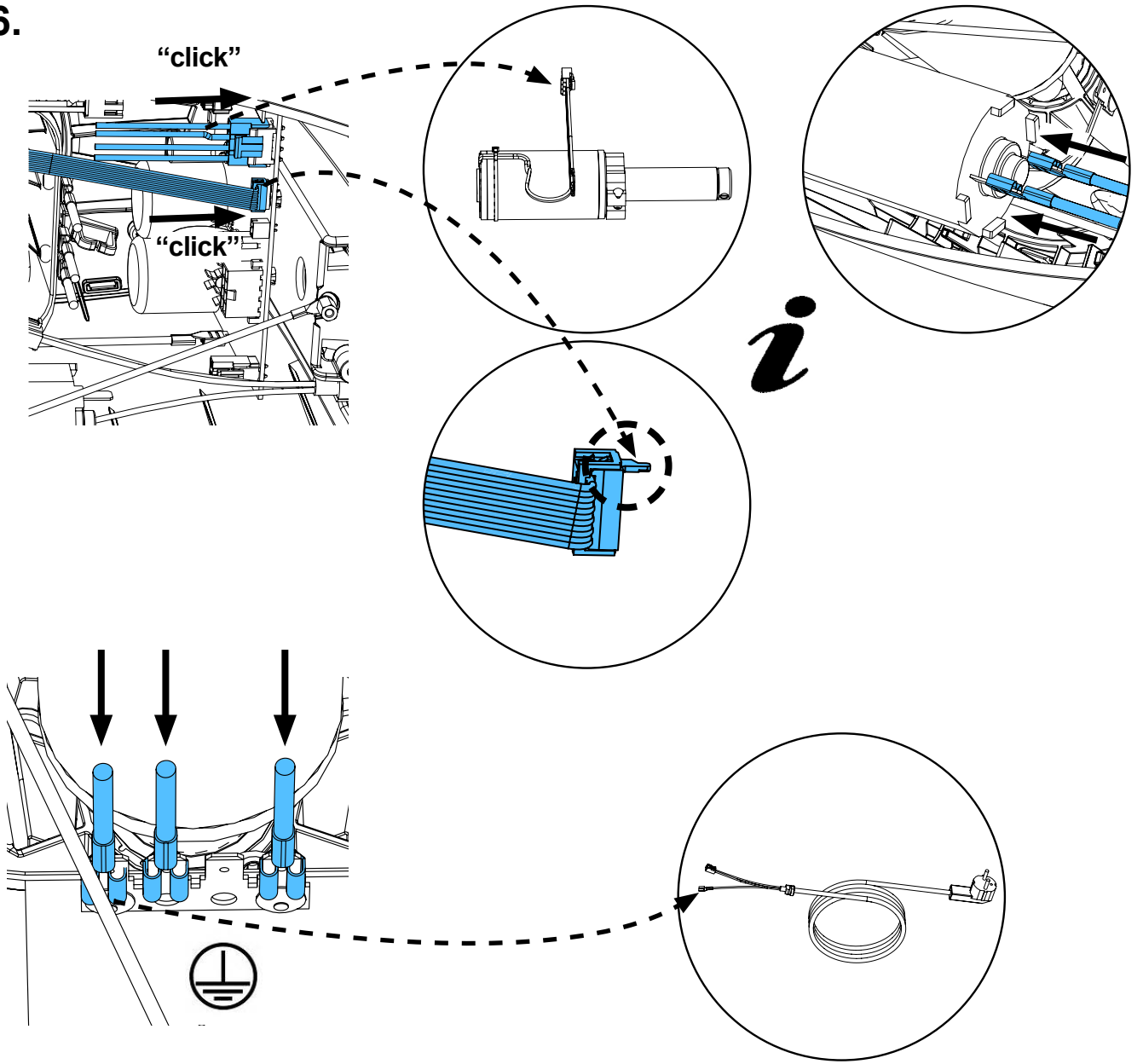

27.

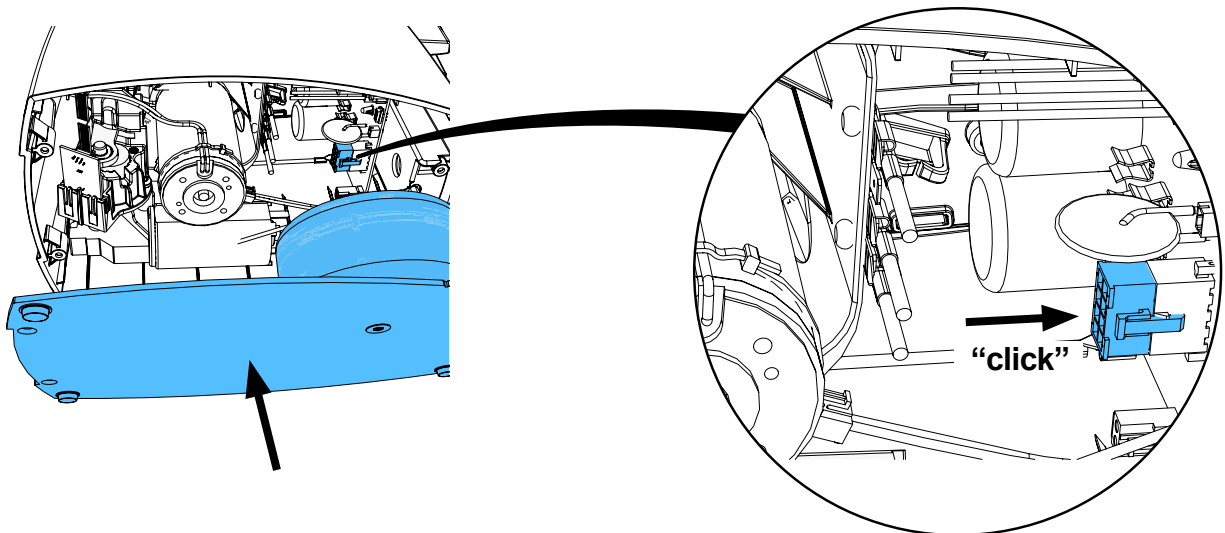

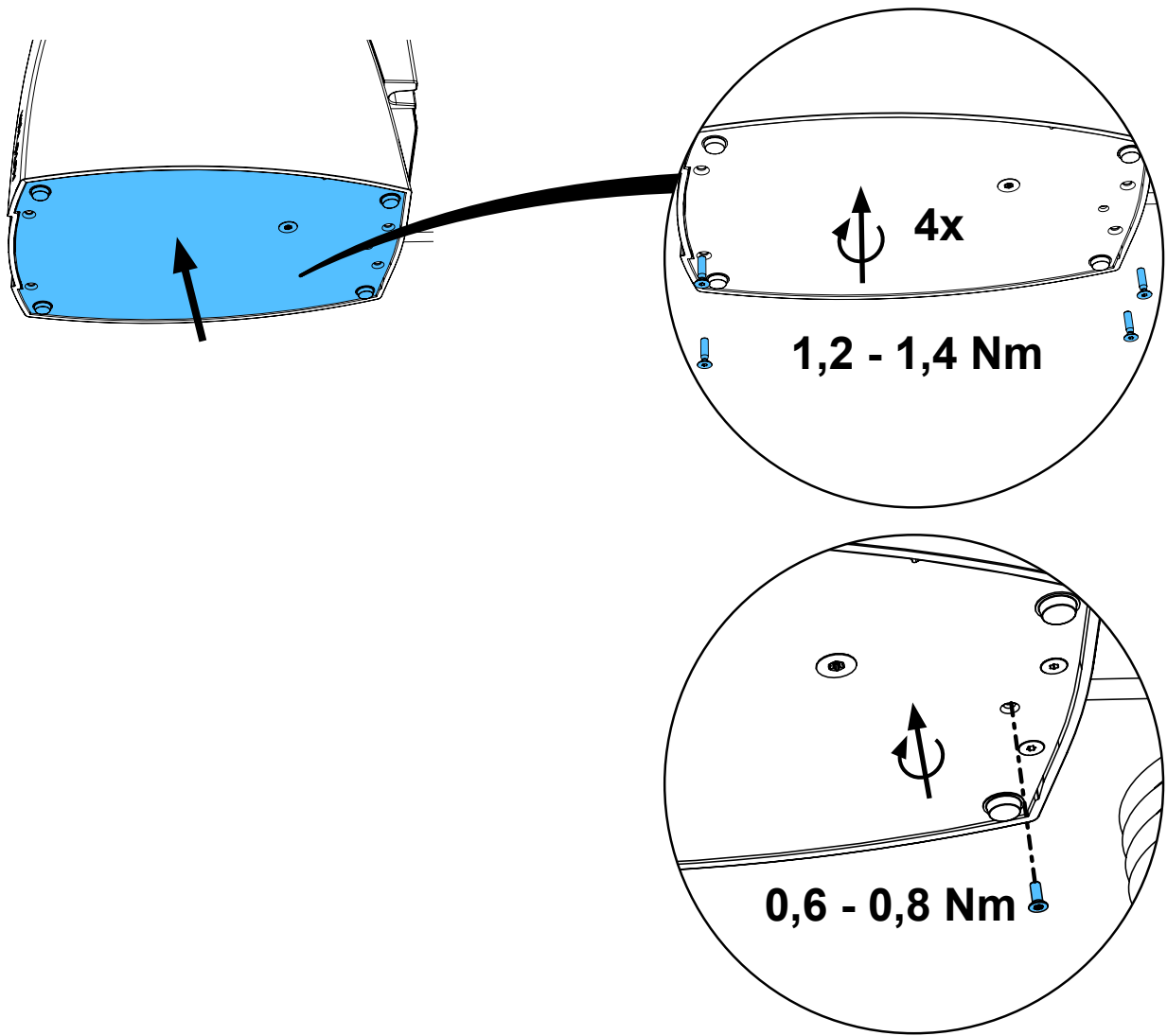

28.

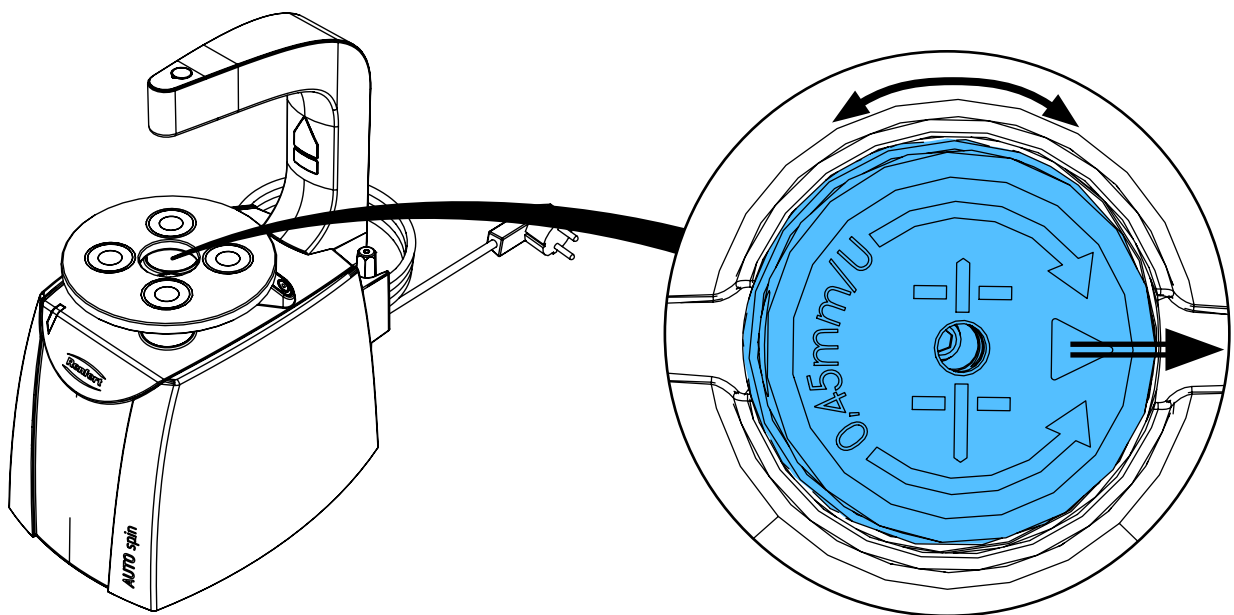

29.

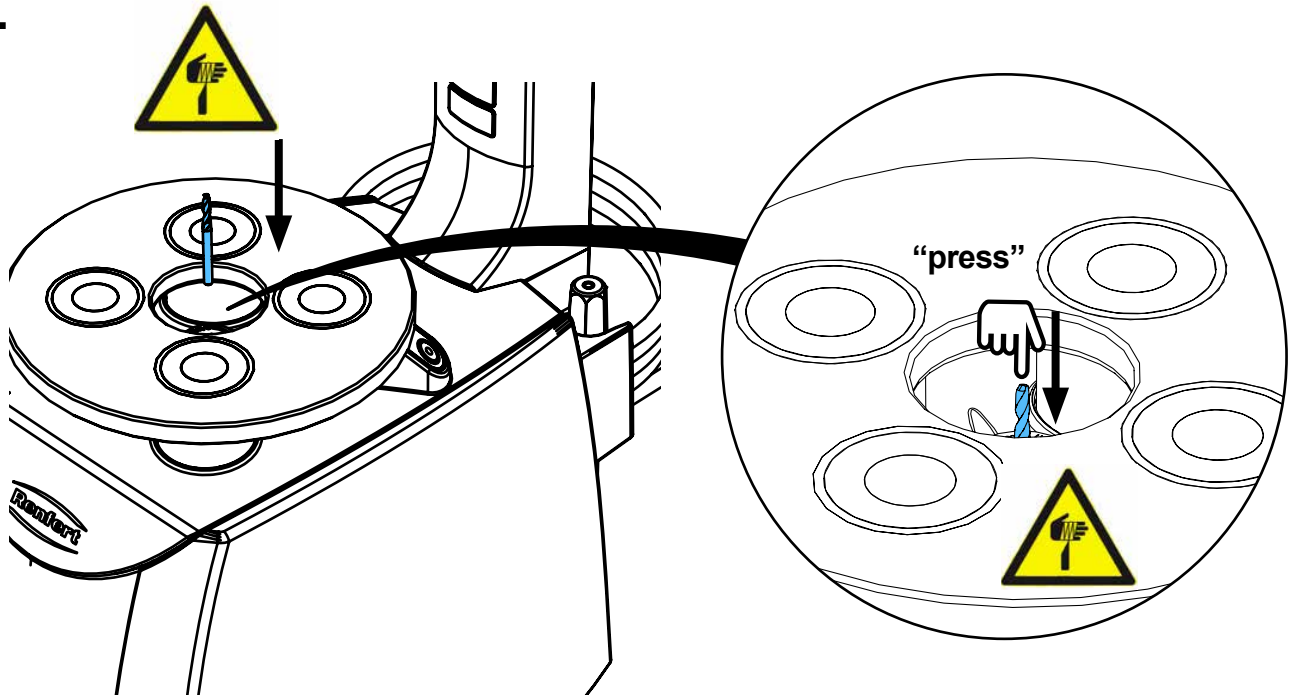

30.

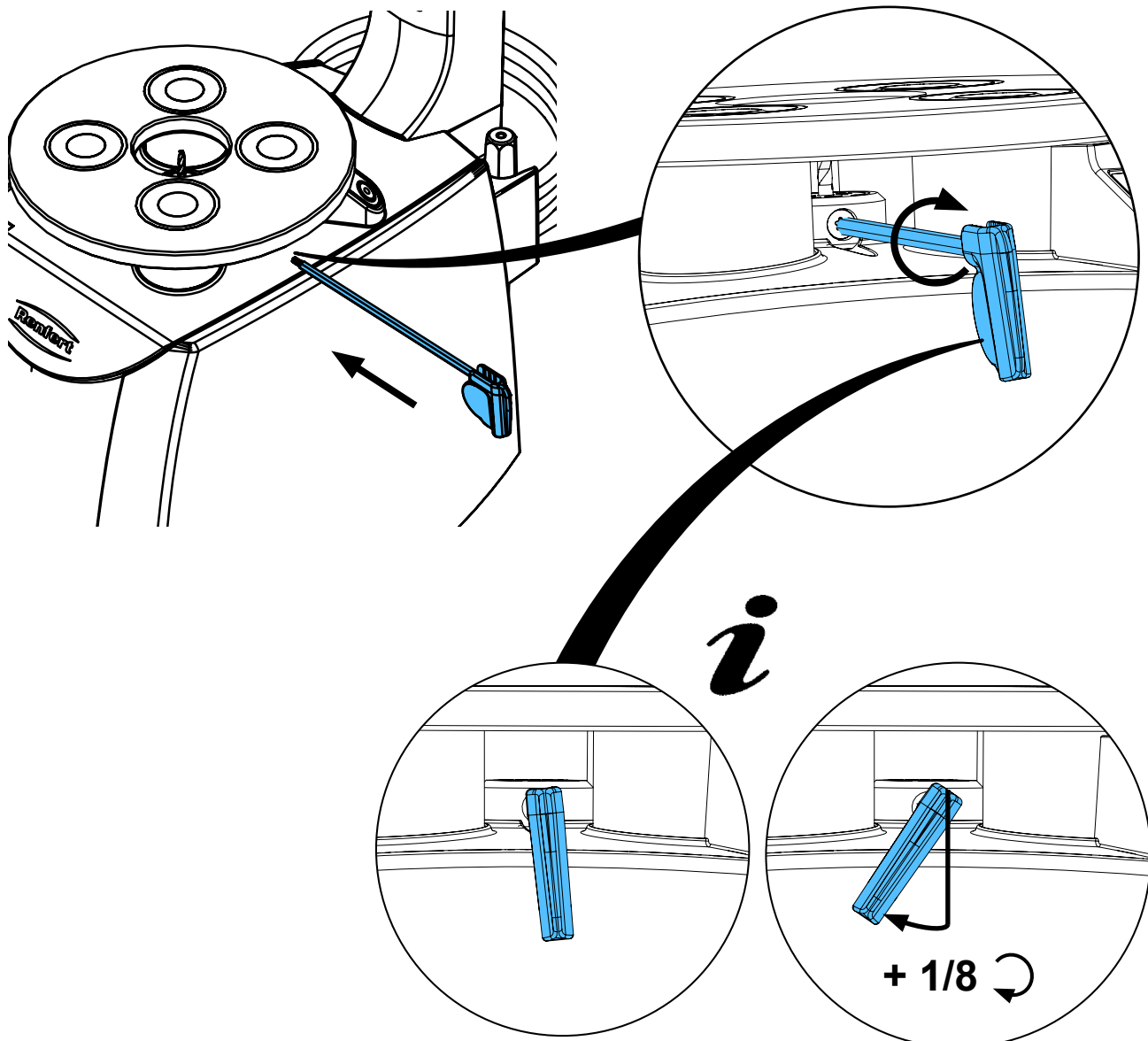

31.



Schutzleiterprüfung durchführen: siehe am Ende der „Service Instructions“.

Performing the protective conductor test: see at the end of the “Service instructions”.

Pour vérifier le conducteur de protection: voir à la fin des “Instructions de service”.

Per la verifica del conduttore di terra: vedere alla fine delle “Istruzioni di servizio”.

Realizar la prueba del conductor de protección: véase al final de las “Instrucciones de servicio”.

Выполнить проверку защитного провода: см. в конце „Инструкции по обслуживанию“.



32.

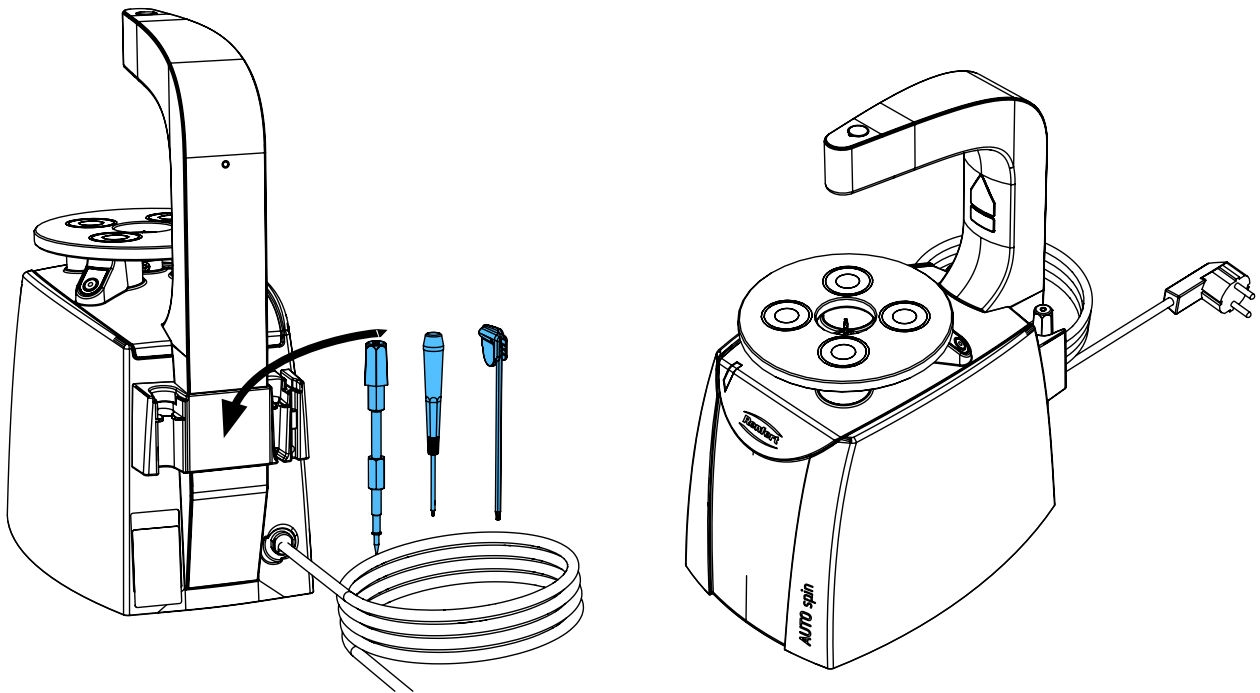



making work easy

90002 1668

Sensorplatine • Sensor board • Platine des capteurs • Scheda sensori • Placa
de sensores • плата датчика

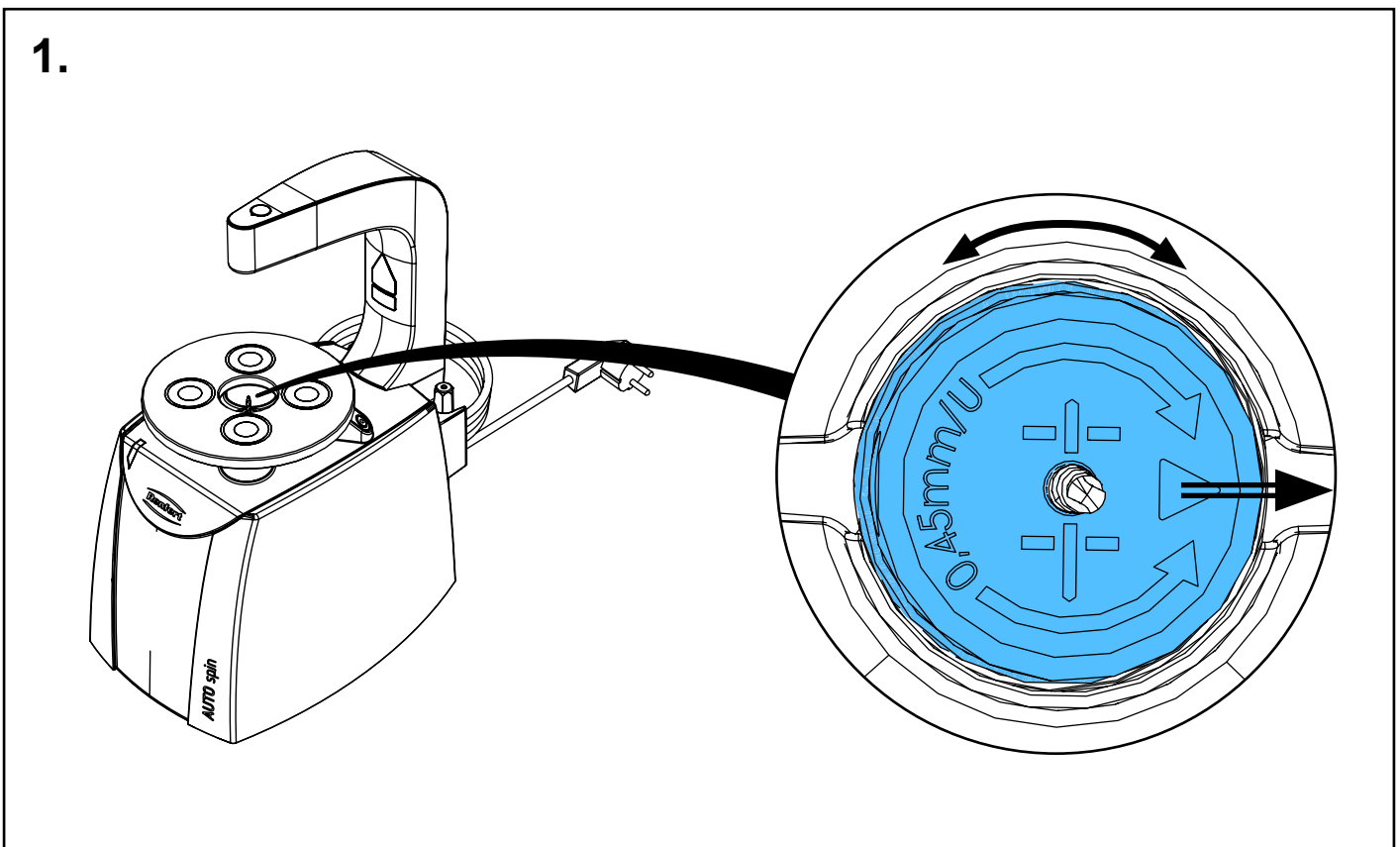
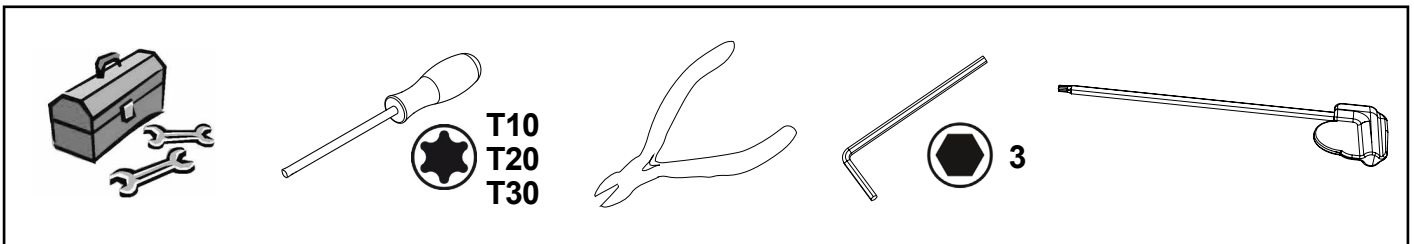
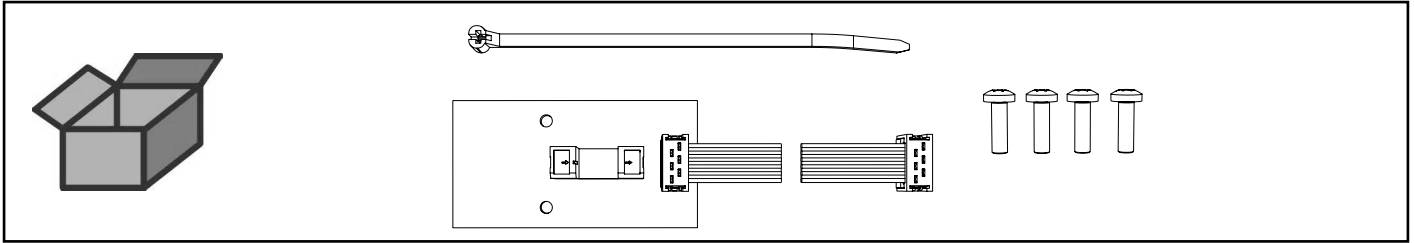

2.

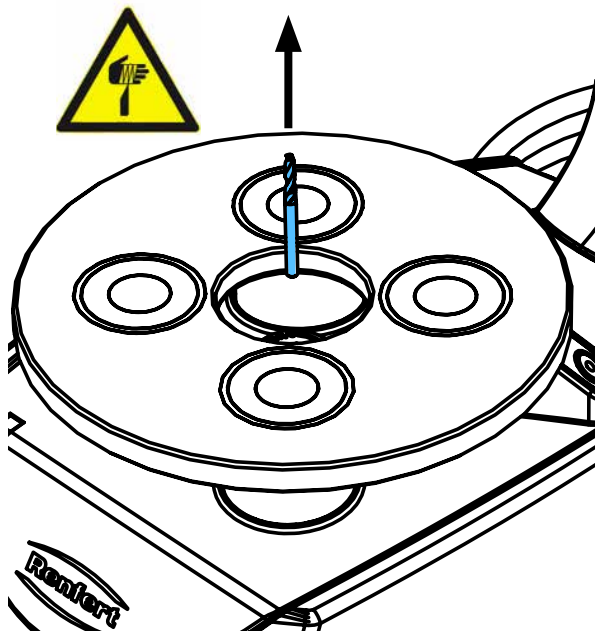
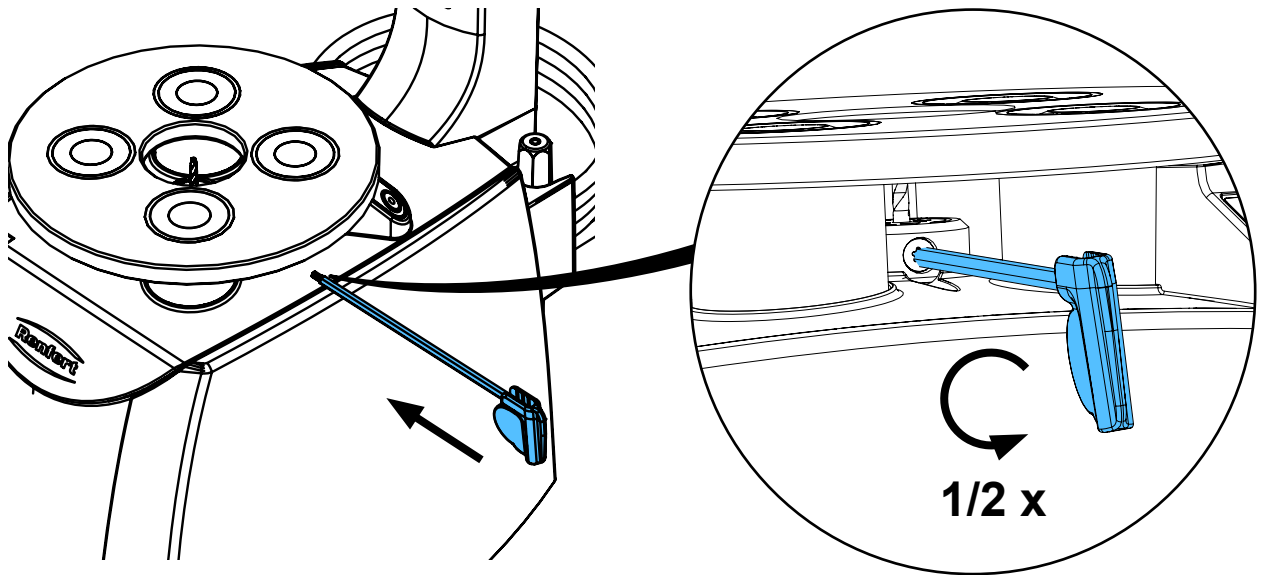

3.

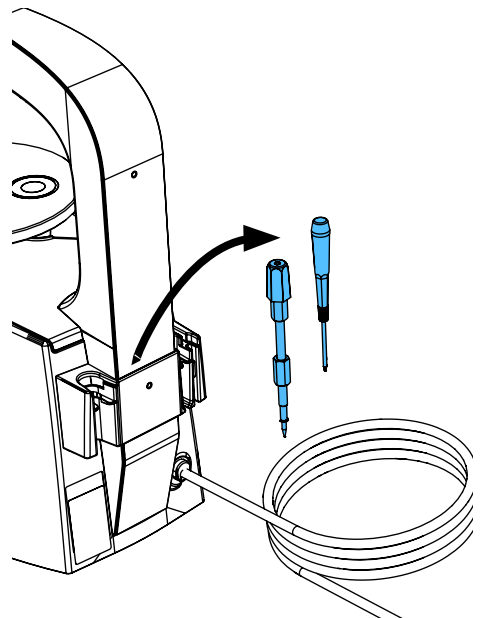
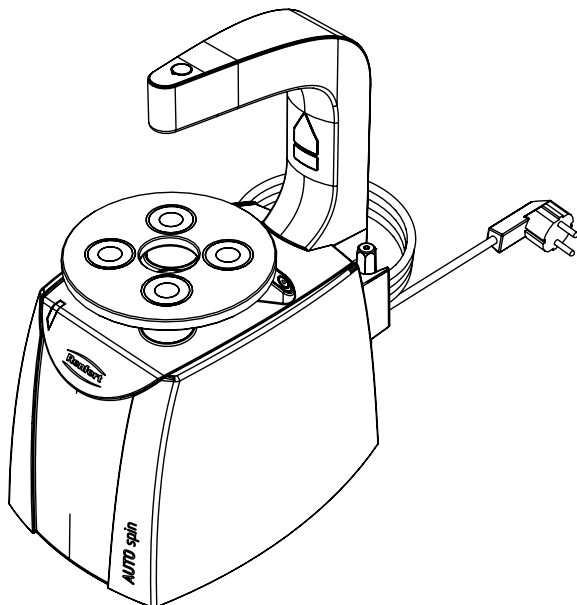

4.

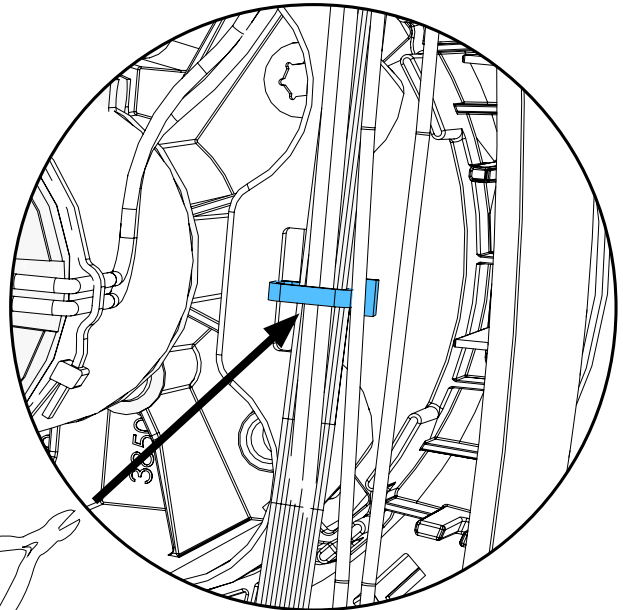
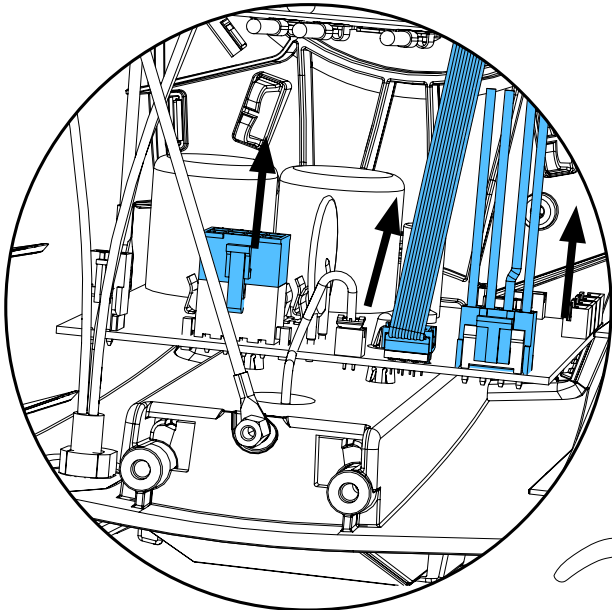
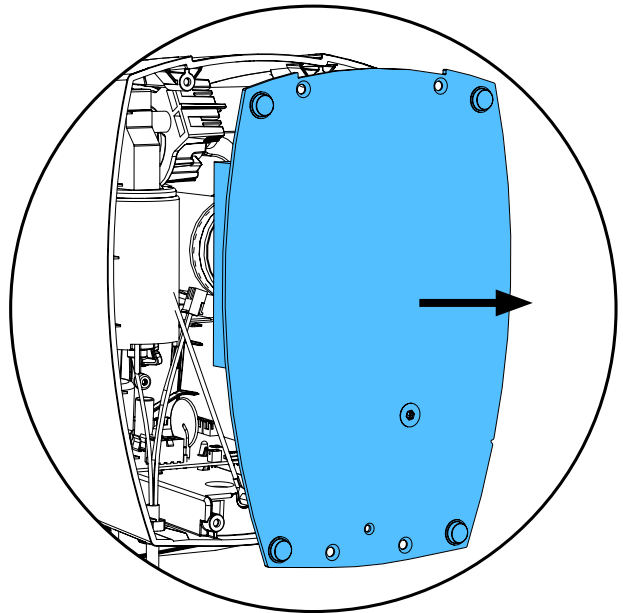
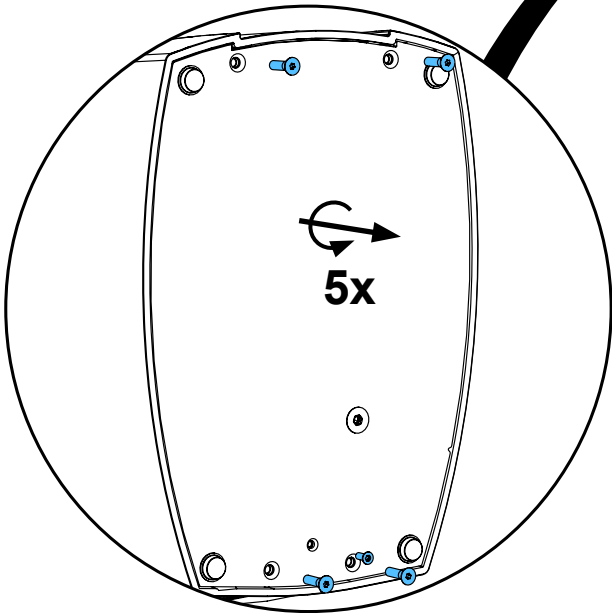
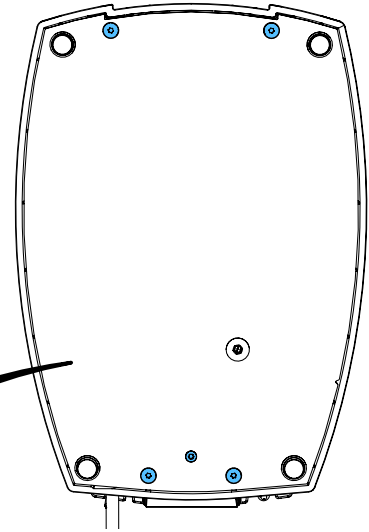
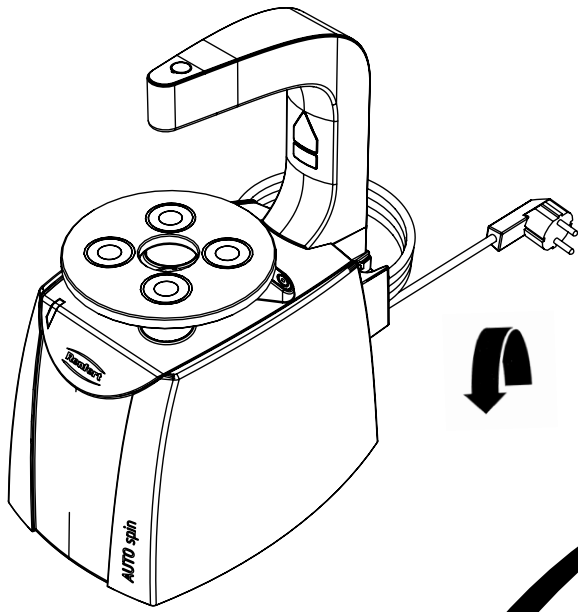

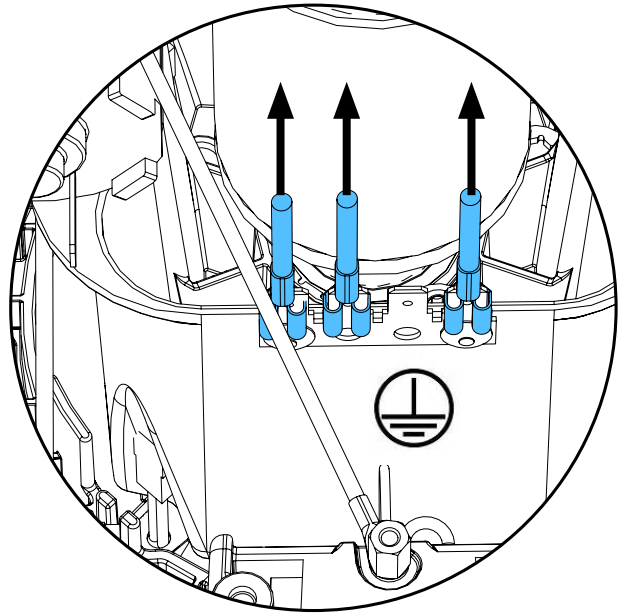
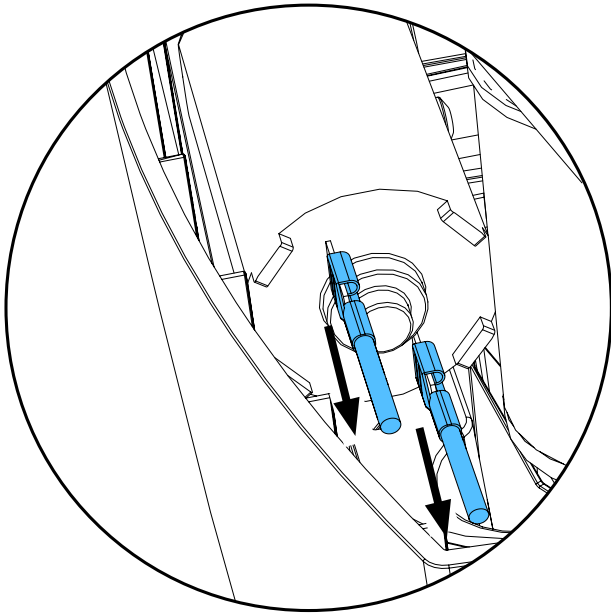

5.

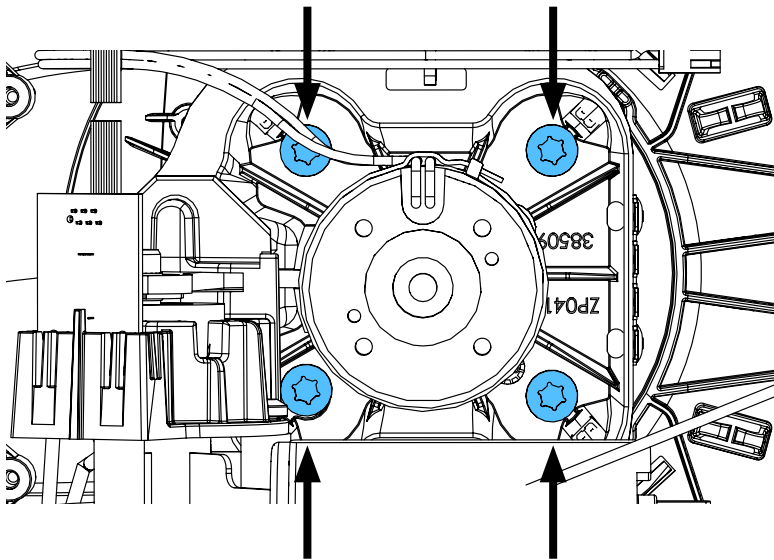

↕ 4x



6.

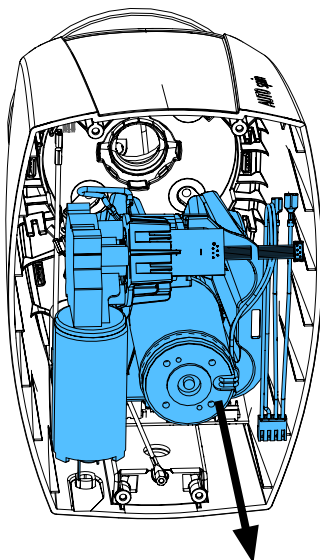

7.

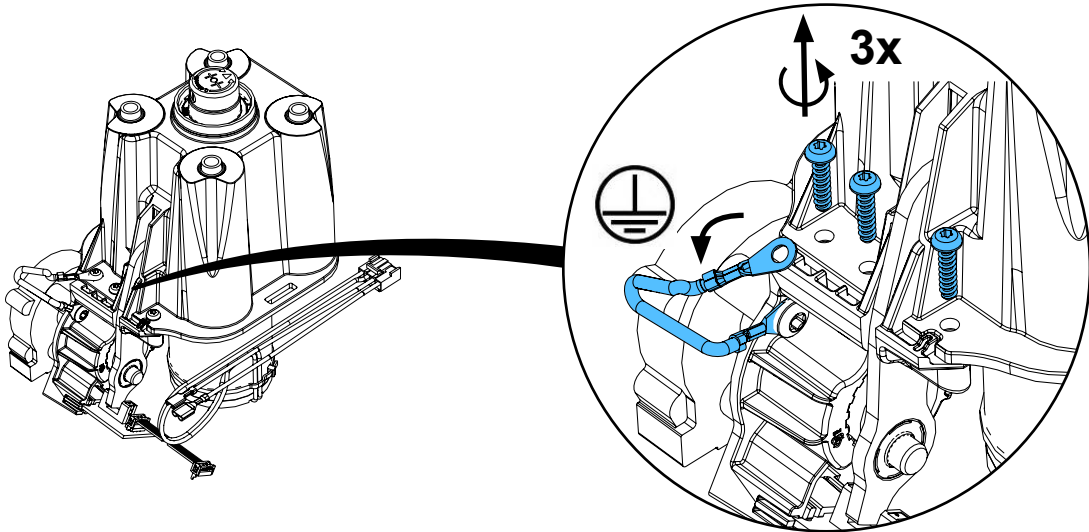

8.

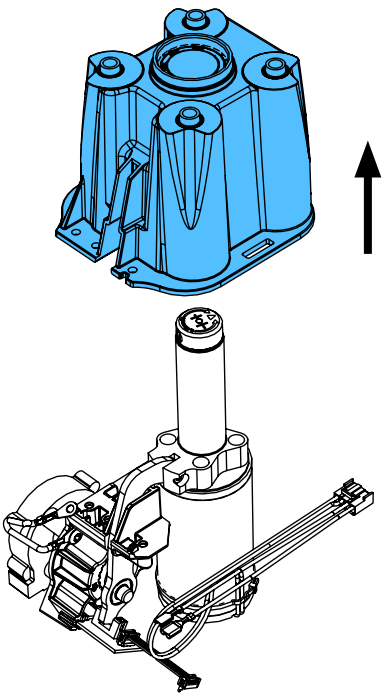

9.

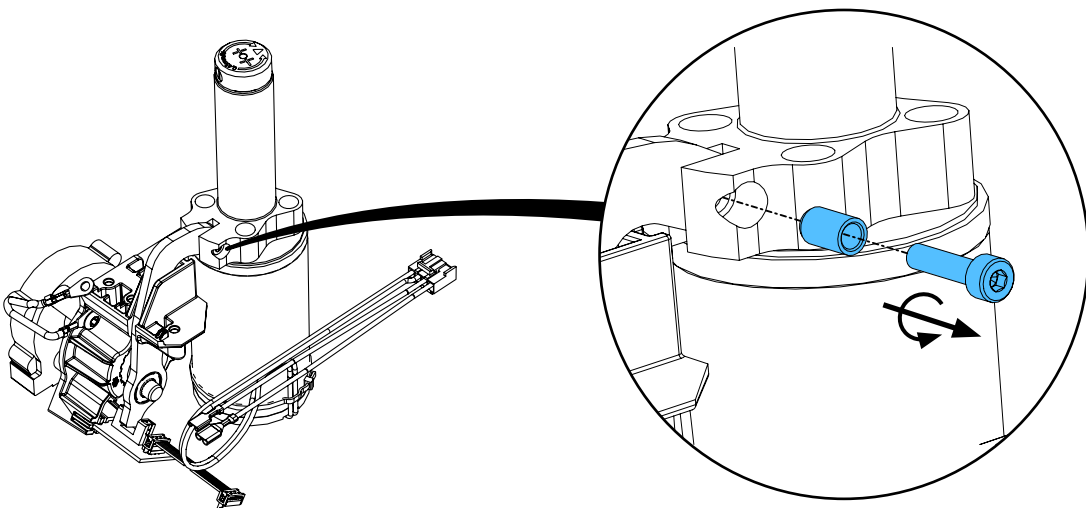

10.

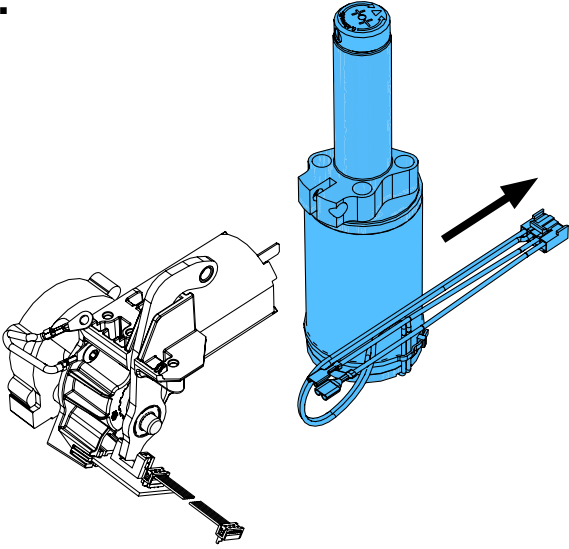

11.

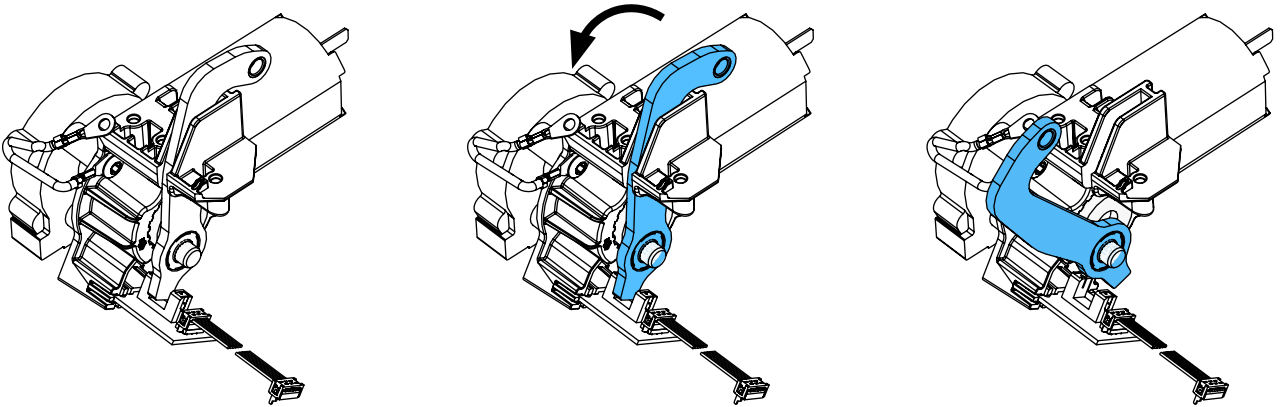

12.

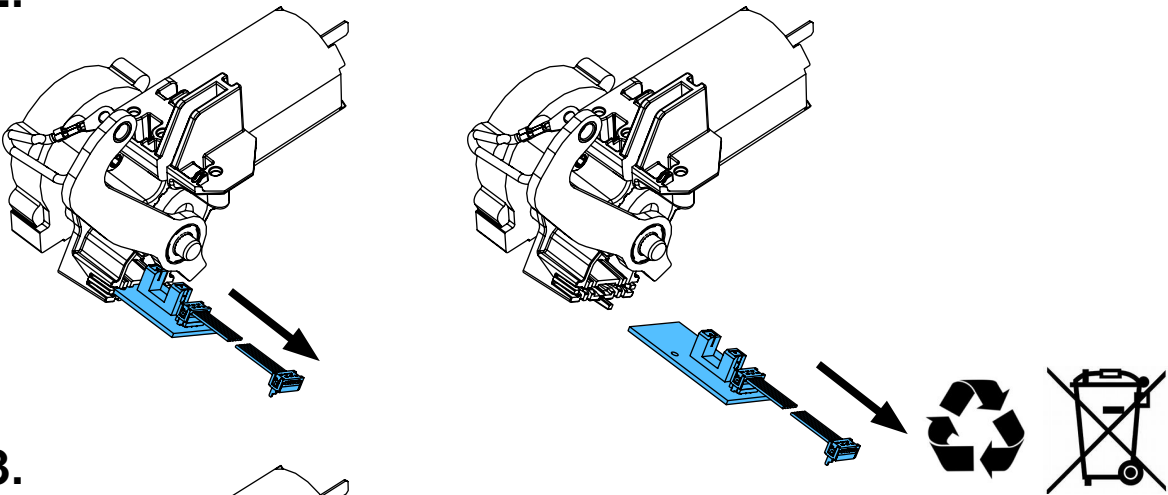

13.

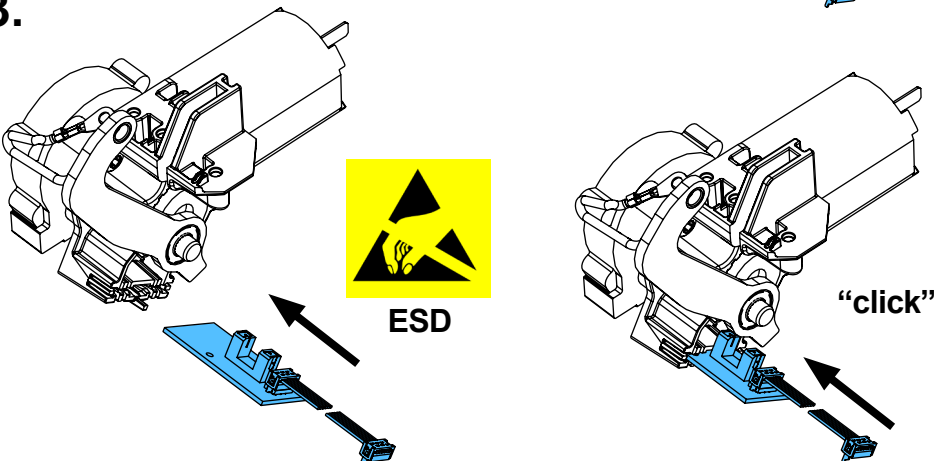

14.

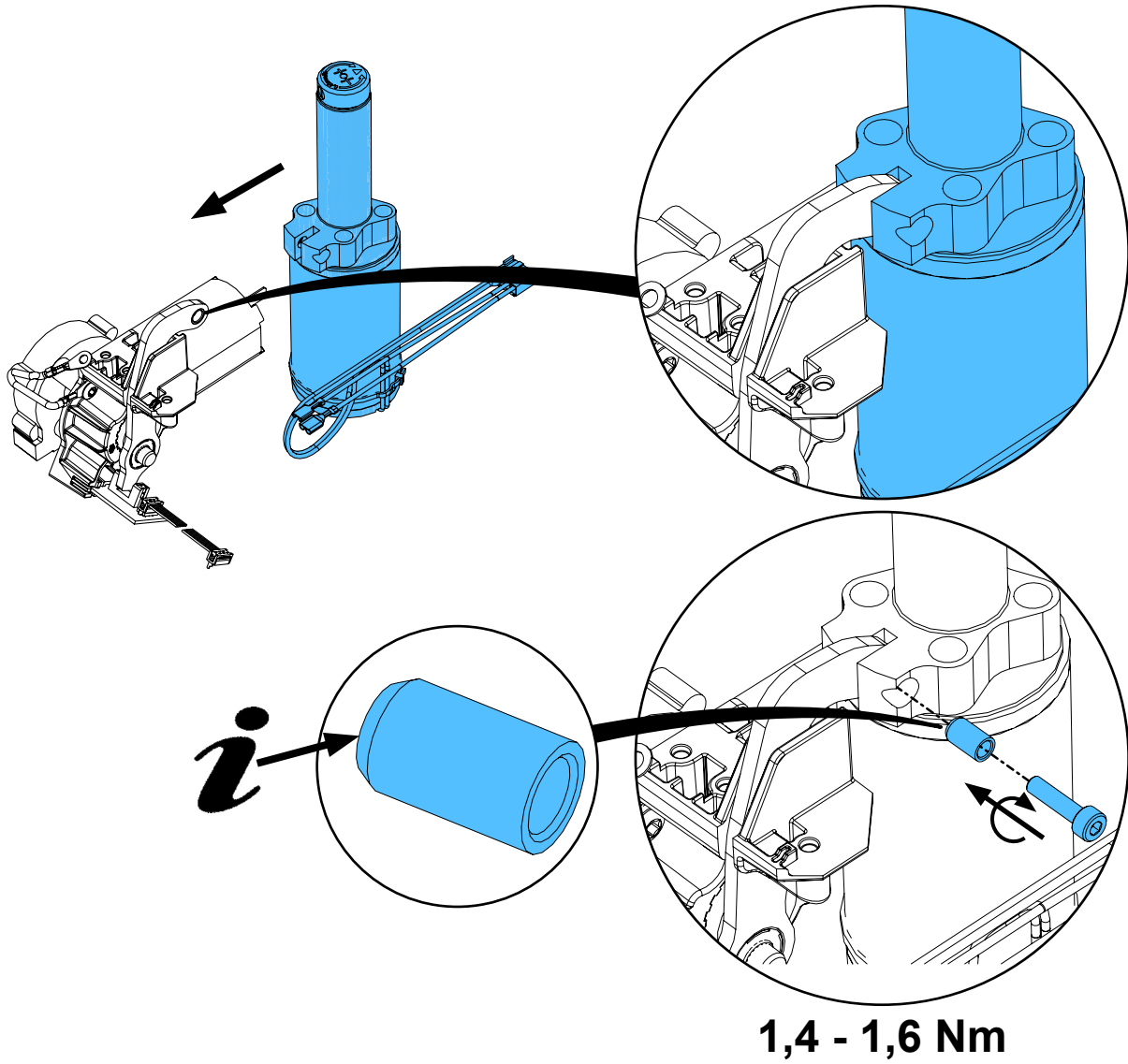

15.

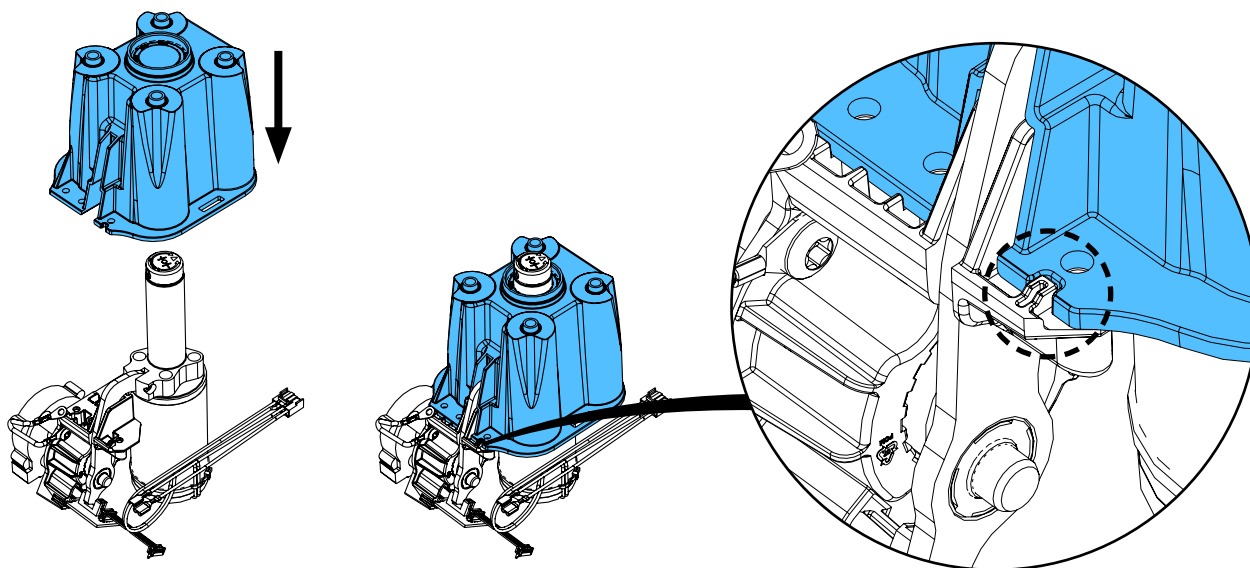

16.

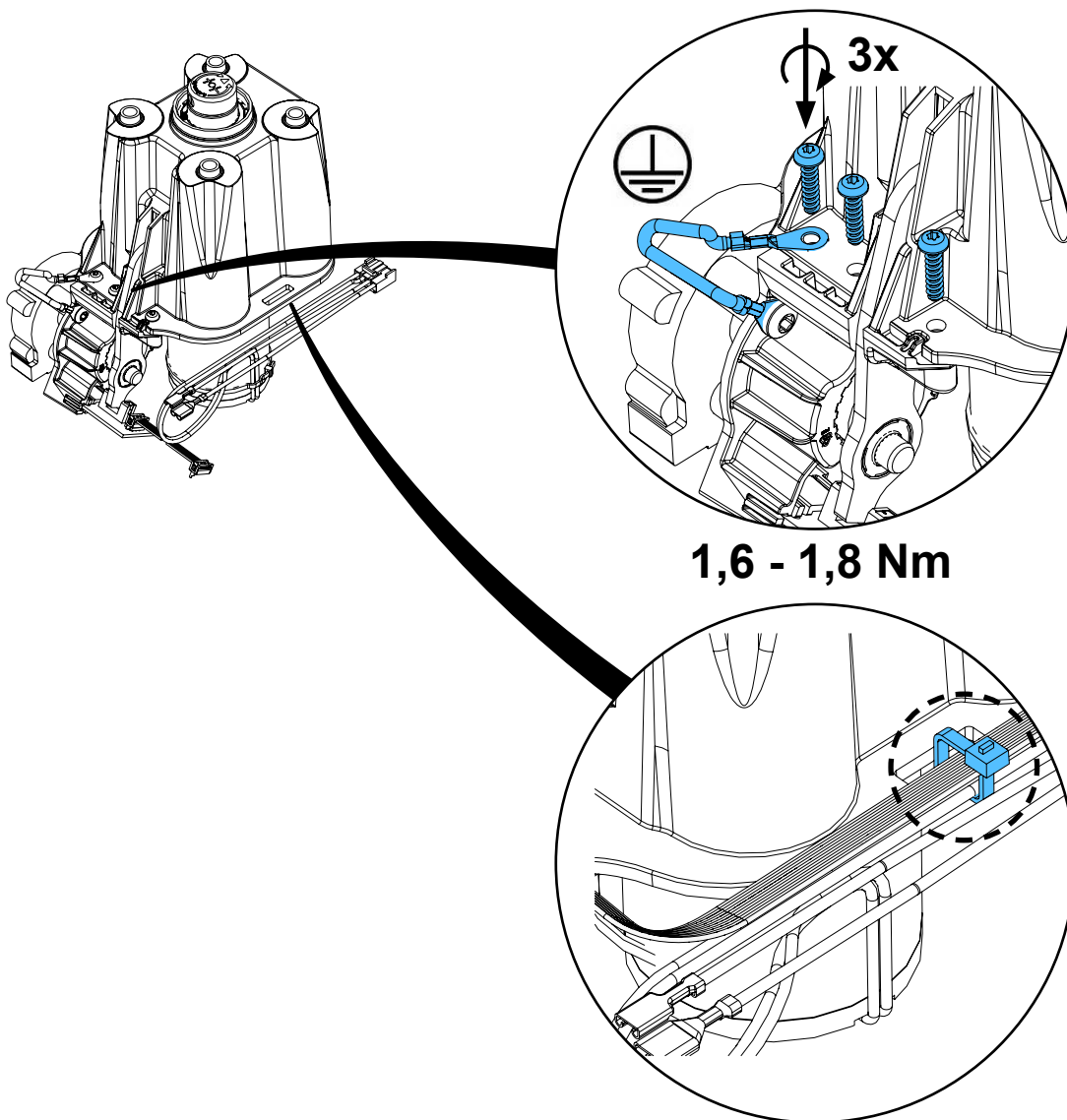

17.

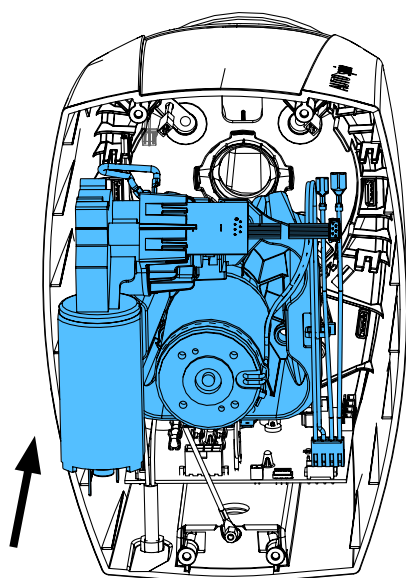

18.

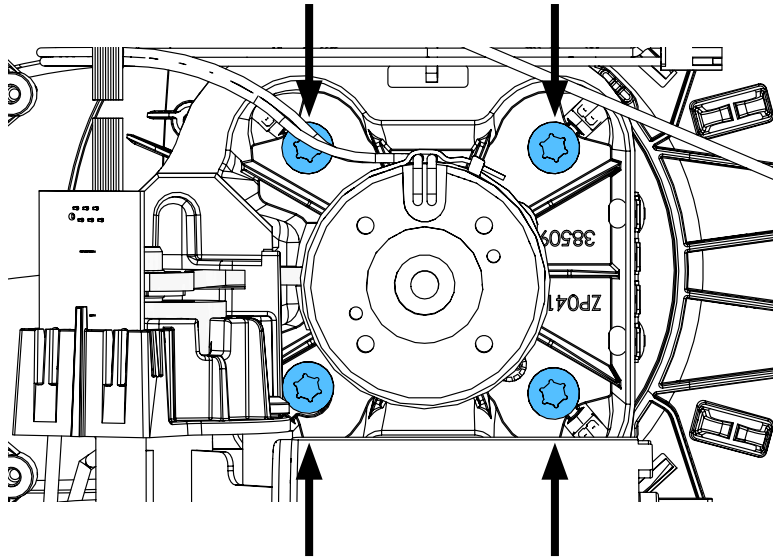
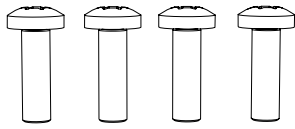

4x
2,5 - 3,0 Nm

19.

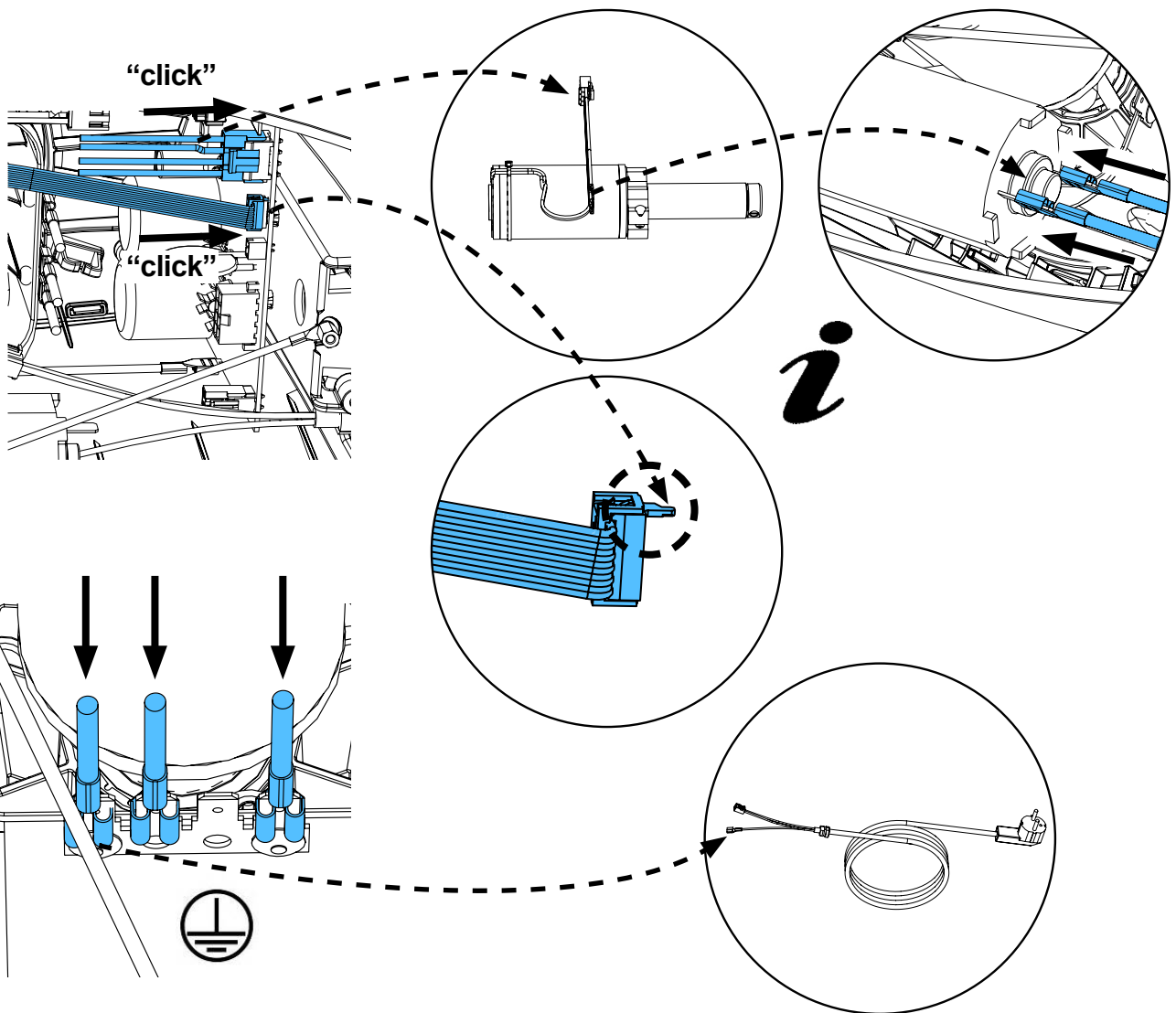

20.

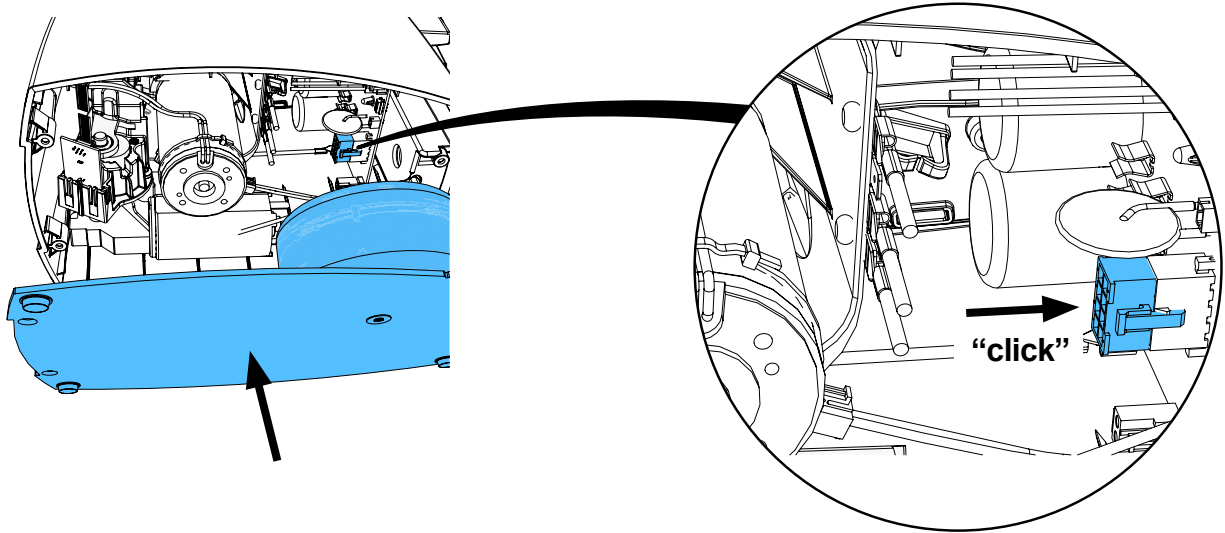

21.

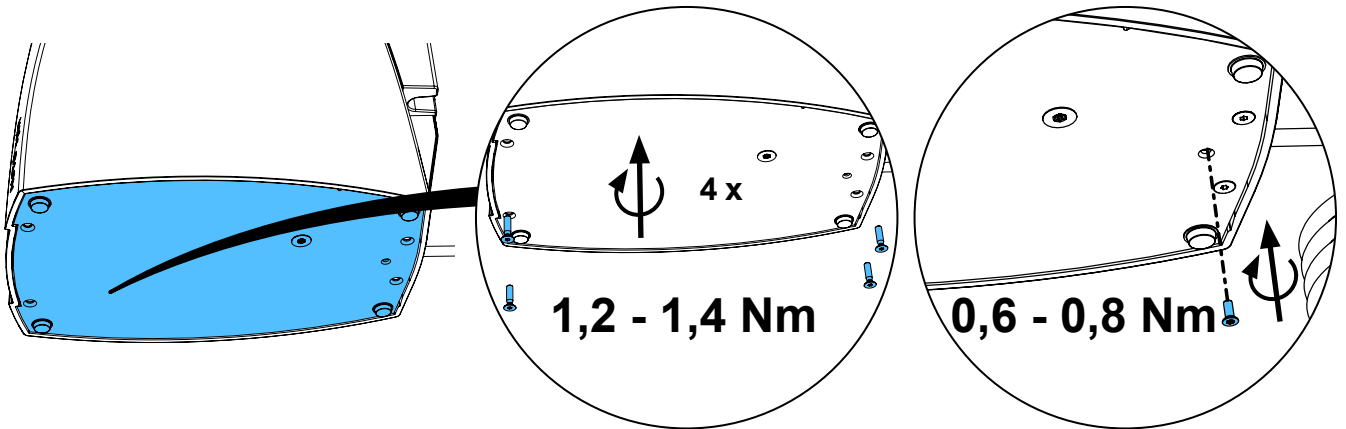

22.

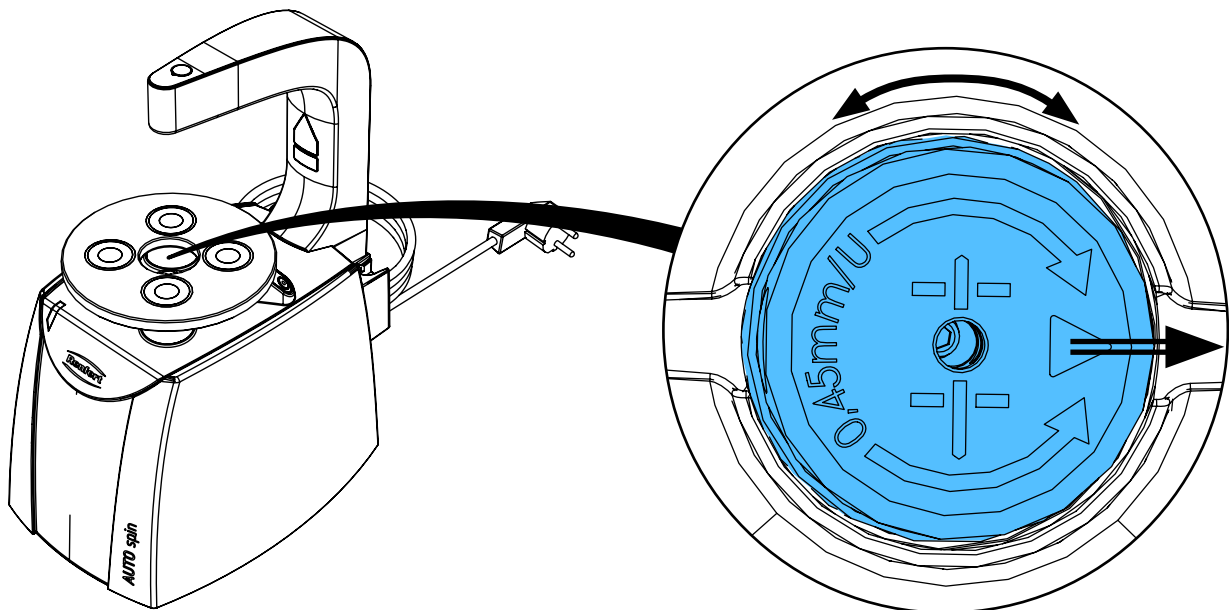

23.

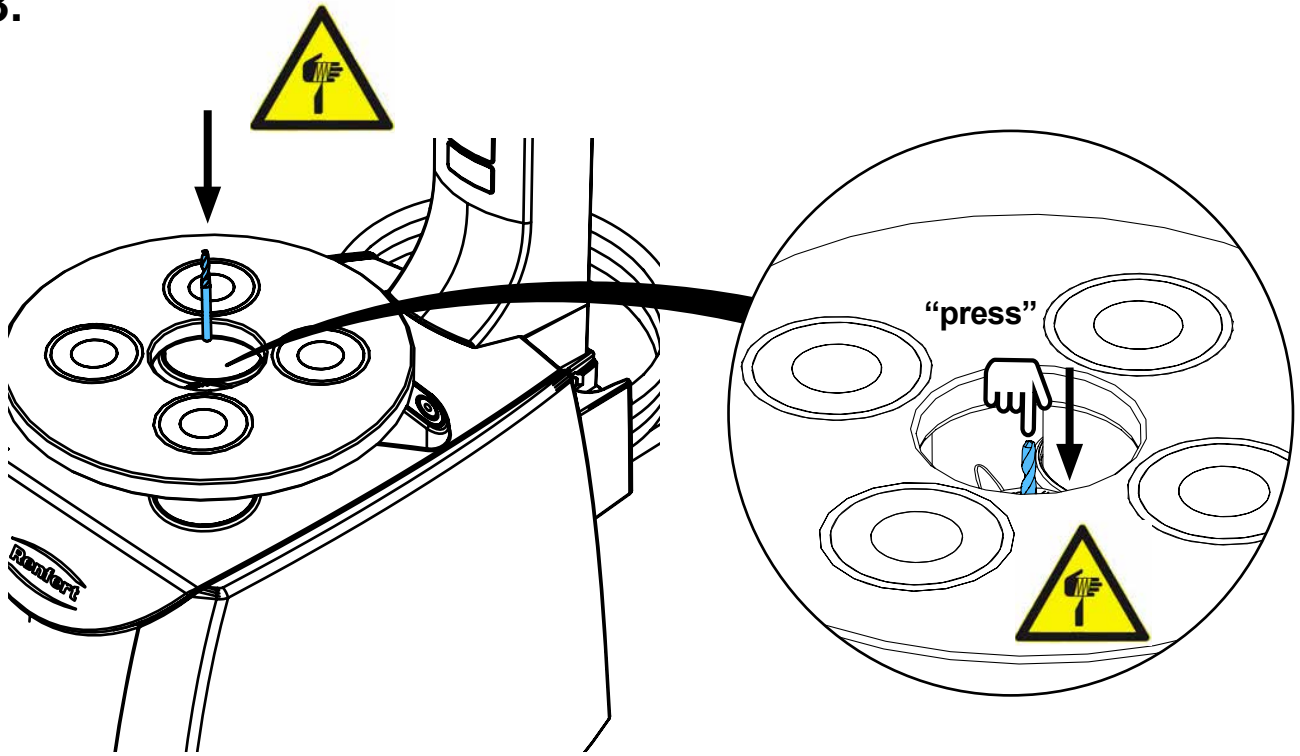

24.

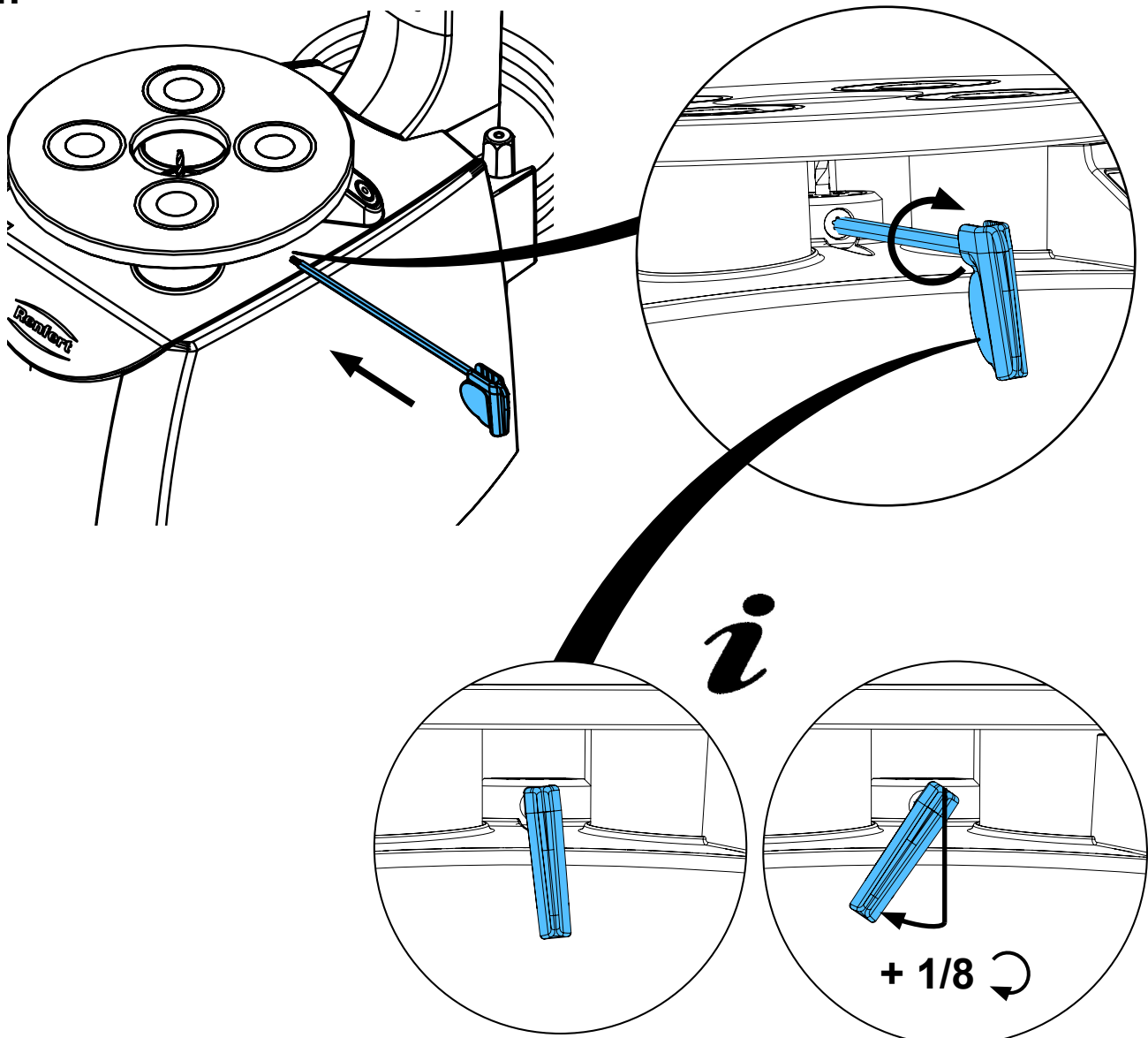

i

25.



Schutzleiterprüfung durchführen: siehe am Ende der „Service Instructions“.

Performing the protective conductor test: see at the end of the “Service instructions”.

Pour vérifier le conducteur de protection: voir à la fin des “Instructions de service”.

Per la verifica del conduttore di terra: vedere alla fine delle “Istruzioni di servizio”.

Realizar la prueba del conductor de protección: véase al final de las “Instrucciones de servicio”.

Выполнить проверку защитного провода: см. в конце „Инструкции по обслуживанию“.



26.

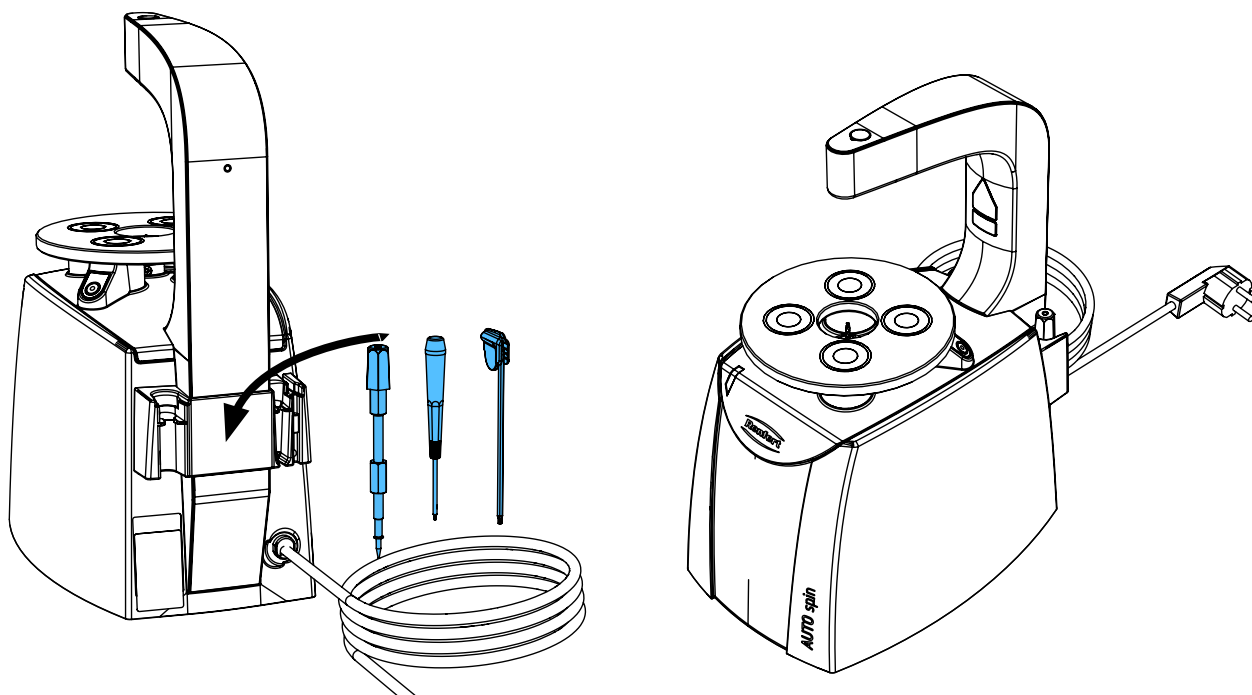



Montageanleitung • Assembly Instruction • Instruction d'installation
Istruzioni l'istallazione • Instrucciones de montaje • Руководство по монтажу

making work easy

90003 7701 / 90003 8000 / 90003 8010

Leiterkarte • Circuit board • Carte imprimée • Scheda stampata • Circuito impresso • Печатная плата

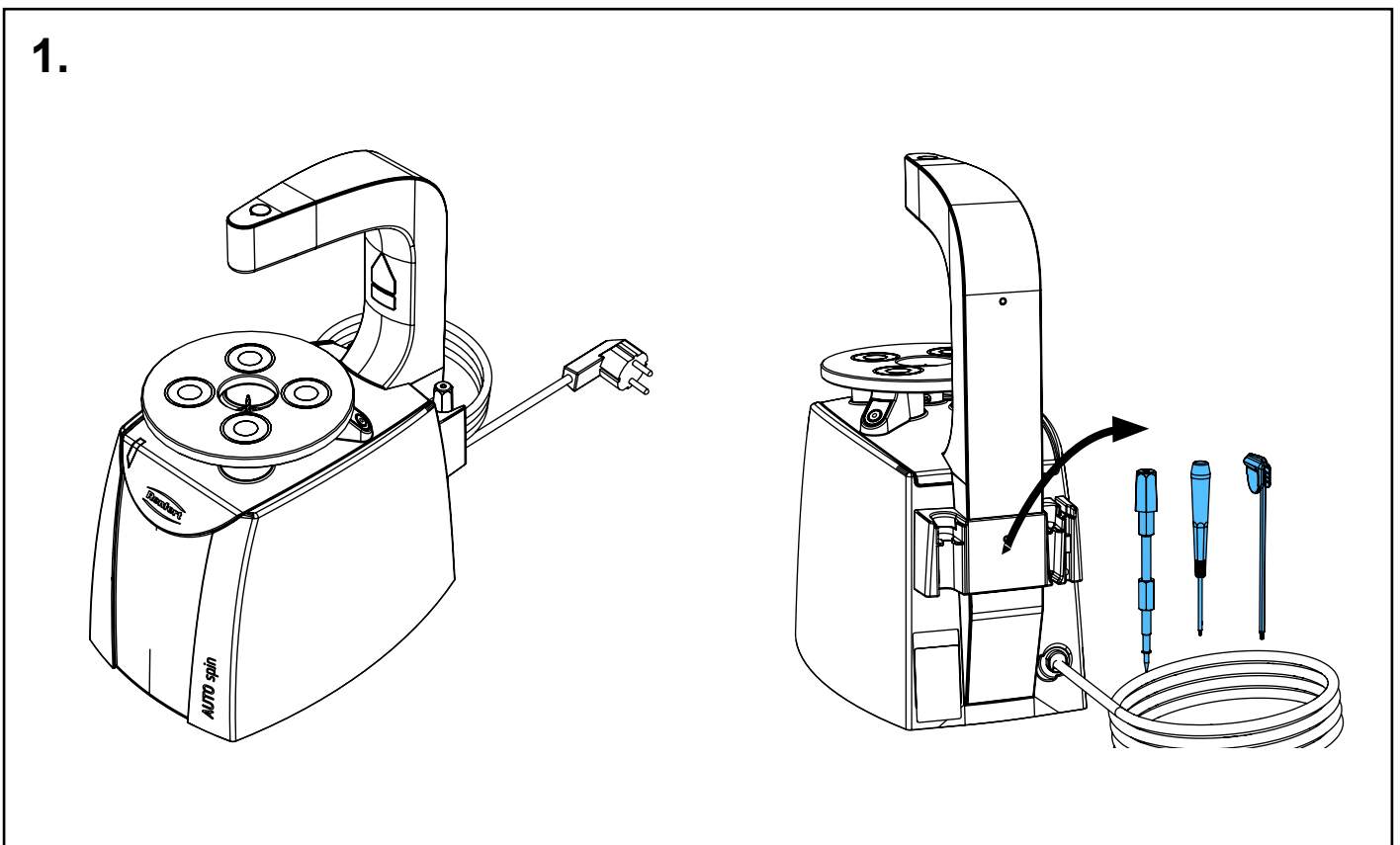
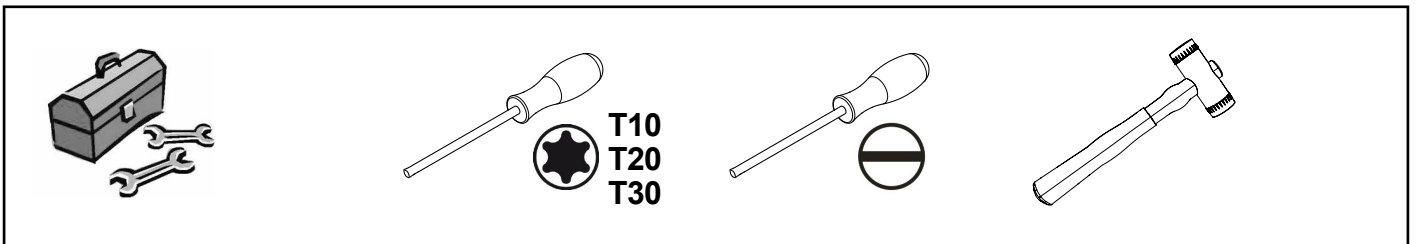
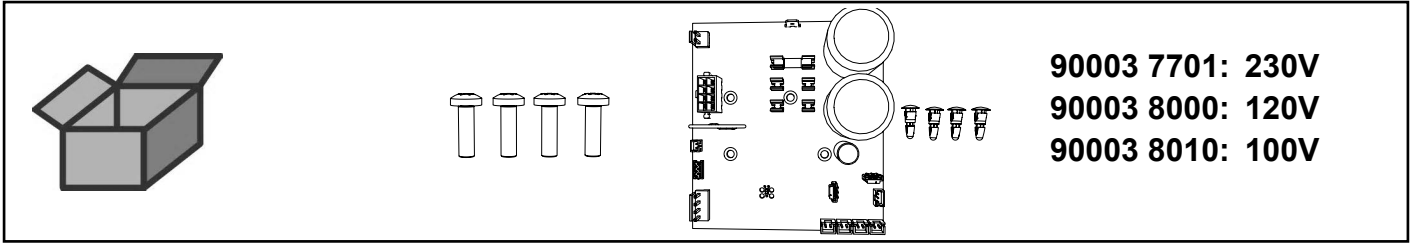

2.

