

4. ADDED AS SECONDARY OPERATION.
 2. ALL CAPACITORS IN MICROFARADS, EXCEPT AS NOTED.
 1. ALL RESISTORS IN OHMS

NOTES: UNLESS OTHERWISE SPECIFIED.

CARVIN
 12340 World Trade Drive
 San Diego, CA 92128
 (858) 487-1600
 FAX 487-6629

BX1500 System Master

DRAWN BY: GEORGE DREYER	DATE: 30MAY05
APPROVED:	DATE:
PCB NO: 30-42500	REV: J
ASSY NO: 80-42500	REV: I
REVISED BY: GEORGE DREYER	DATE: 31MAR10

Rev G first proto of BX1500, change from BX1200 pre-amp/power to BX1500 preamp section only Using 30-02004 for power amp.
 Rev H Cable header changes and new compressor circuit.
 Rev I compressor changes on PCB done in secondary on rev H added add cap to filament ground.
 Rev J reverse C125 polarity and removed pot ground short to signal ground.

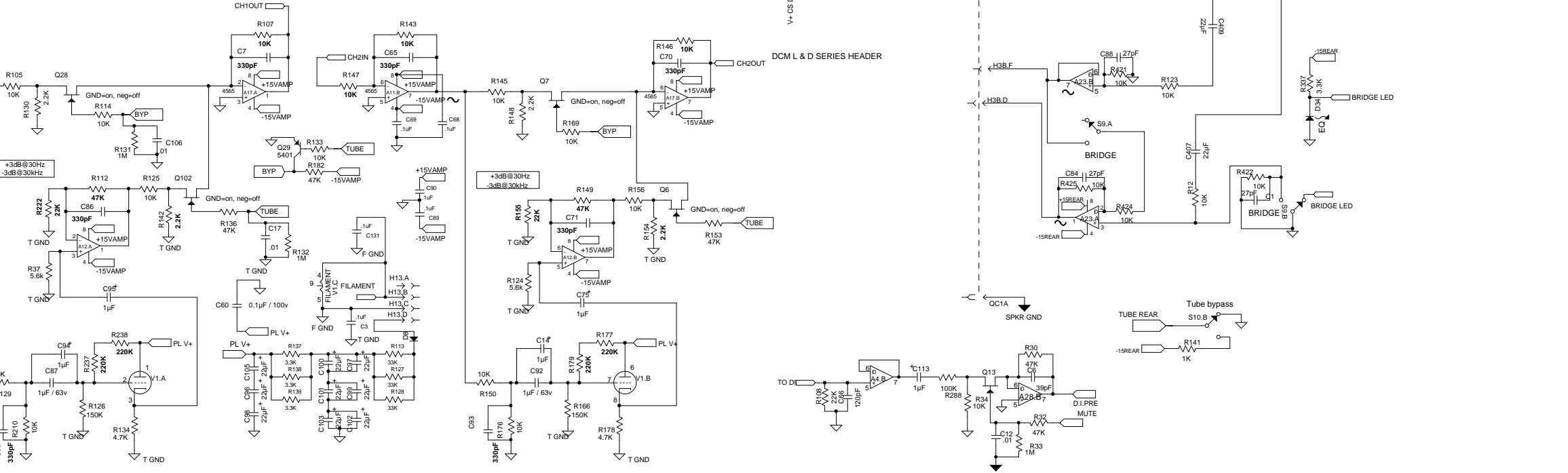
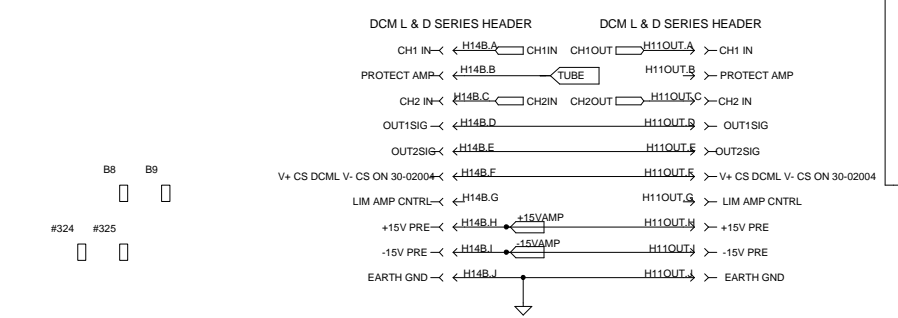

Changes from Assembly Rev (F).
 1. Amplifier removed and header assembly changed to Work with 30-02004 Class D amplifier PCB