



**CONGRATULATIONS** on your purchase of Carvin's XP800L mixer! The XP800L model includes 2 built-in high power amplifiers for direct hook-up to your speakers. Please read this manual carefully to take all the advantages of your new mixer.

**SUPERB SOUND** is derived from the extremely low distortion, "high headroom" design. State-of-the-art, low noise, balanced XLR preamps from our Concert Series mixers provide common mode rejection of better than 78 dB, which means that any noise that may come over your cables is virtually eliminated. Distortion is nearly non-existent with THD below 0.1% from input to output, guaranteeing the purity of your sound. Hear the difference - your sound will not seem sterile or processed. It will be dynamically open and transparent just like it was meant to be!

**LIGHT WEIGHT / EASY TO USE** Controls are logically laid out making the XP Series simple to use, reducing errors during setup and performance. Its compact size and weight of only 10 lbs. makes it the lightest, most powerful mixer in its class.

**2 HIGH CURRENT "GREEN" CLASS-D AMPLIFIERS** produce total of 500 watts RMS, 750 watts peak. Class-D amps not only run cooler, but are also energy efficient. Use both amps in stereo (250w/250w) for MAIN L and R speakers, or switch to 250watts for MAIN and 250watts for MONITORS. This is the kind of output power that maintains the purity and integrity of your sound.

**HIGH CURRENT "GREEN" SWITCHMODE POWER SUPPLY** conserves power by operating at higher efficiency. The DC voltage supply is recharged 100,000 times per second, delivering continuous high current to the power amps.

**24-Bit DSP STEREO EFFECT PROCESSOR** delivers professional level effects. You get awesome lush Reverbs, rich Chorus, crisp Delay and Echo, and thick, layered Flanging – all with full bandwidth and pristine clarity. Effect level is adjustable to your stage monitors so you can hear yourself with full effects. 256 effect variations include fully adjustable parameters for damping, decay, depth, speed, regeneration and time.

**ACTIVE 3 BAND CHANNEL EQ** provides easy adjustment for the tone you want. The 80Hz LO frequency controls deliver solid non-flabby bass. A simple adjustment with the MID band control brings out the best sound for vocals or guitar by affecting the very important 750Hz frequency range. The 11.5k Hz HI treble control adds sparkle to your top-end without adding harshness. Both the LO and HI controls are "shelving", which means they are effective from 20Hz to 20kHz.

**DUAL 7-BAND EQUALIZER** provides precise adjustments to fine tune your overall sound and to help control feedback. The stereo (dual) graphic equalizer controls the main L and R outputs or switch to MAIN/MONITOR with one press of a button.

**ENGINEERED TO LAST** Every XP Series mixer incorporates a rugged steel chassis with protective side panels. Continuous full power is assured from a high-grade 6063-T5-aluminum heat sink. Sealed controls and switches guard against the outside elements while heavy-duty connectors provide a positive connection to your cables. Hidden deep in the heart of these mixers is the "SMT" Surface Mount Technology construction that utilizes surface mounted components to prevent parts from shaking or vibrating loose. Precision 1% tolerances guarantee that your settings will be accurate every time. Fire retardant FR-4 military spec circuit cards feature double-sided copper construction to guard against noise and radio frequencies (RF). The XP Series is made in the USA for years of dependable service!

### RECEIVING INSPECTION—read before getting started

INSPECT YOUR MIXER FOR DAMAGE which may have occurred during shipping. If damage is found, please notify the shipping company and CARVIN immediately.

SAVE THE CARTON & ALL PACKING MATERIALS. In the event you have to re-ship your unit, always use the original carton and packing material. This will provide the best possible protection during shipment. CARVIN and the shipping company are not liable for any damage caused by improper packing.

SAVE YOUR INVOICE. It will be required for warranty service if needed in the future.

SHIPMENT SHORTAGE. If you find items missing, they may have been shipped separately. Please allow several days for the rest of your order to arrive before inquiring.

RECORD THE SERIAL NUMBER on the enclosed warranty card or below on this manual for your records. Keep your portion of the card and return the portion with your name and comments to us.

For your records, you may wish to record the following information.

Serial No. \_\_\_\_\_ Invoice Date \_\_\_\_\_

### XP800L BLOCK DIAGRAM

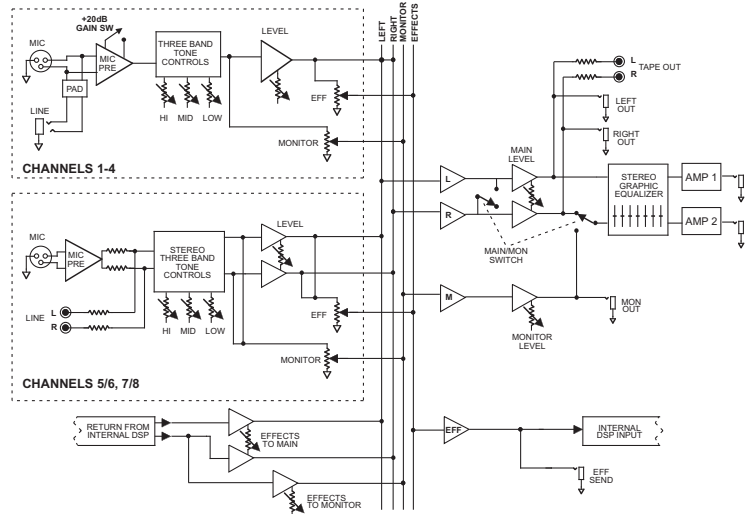

### MODEL XP800L SPECIFICATIONS:

Frequency Response:	Mic or Line Inputs: 20Hz-20kHz ±1dB
THD:	Less than .1% at nominal levels
Equivalent Input Noise:	150 ohm source: -117dBu
Output Noise:	-90dBu Master Line Out (All Levels Minimum)
Output Headroom:	+20dB
Maximum Gain:	Mic in to Master Line Out: 70dB
Crosstalk:	Adjacent ch's: -60db at 1KHz
CMRR:	-78db at 1KHz
Phantom Power:	48volt @ XLR Mic channels
USB Power port:	5volt, 250mA for LED lighting or MP3 charging
Channel EQ, 3-band active:	LOW: 80Hz ±12dB MID: 750Hz ±12dB HI: 11.5KHz ±12dB
Power Output:	500wRMS (2x250w@4ohms), 750w peak total
Power Req.:	100-140VAC or 200-250VAC, 50-60Hz
Size (H x W x D)	7.5" x 13.5" x 9" (190mm x 343mm x 229mm)
Weight:	10 lbs (4.55kg)
Accessories:	UX600R wireless receiver (requires UX600KIT) UX600KIT mounting bracket for up to two UX600R FS22 footswitch for effects on/off CV800 Vinyl Cover



16262 WEST BERNARDO DR. SAN DIEGO, CA 92127  
www.carvinaudio.com

# XP800L CONTROLS

## QUICK START UP

If you're like most new owners, you're probably in a hurry to plug your mixer in and use it. Here are some brief instructions to get you going quickly. With the mixer unplugged and the unit turned off, complete the following procedures:

### A. CONNECTING AC POWER TO YOUR MIXER

- Be sure to plug your mixer into the proper AC voltage marked on the rear of your mixer.
- Use only a grounded (3 prong) power outlet to prevent a shock hazard (do not bypass). This also gives the quietest grounding for your mixer.

### B. CONNECTING INPUTS TO YOUR MIXER

- For balanced microphones, use a shielded cable and plug into the XLR MIC inputs.
- For high output devices like instruments & keyboards, plug into the LINE input jacks using a shielded cable.
- Set the MIC IN switch "OUT" for instruments or "IN" for microphones.

### C. TURNING YOUR MIXER ON

- Set all channel and master LEVEL controls to their OFF positions
- Set all HI, MID, and BASS controls and the graphic equalizers to their center "flat" (no boost or cut) position.
- Connect your speakers at the front panel.
- Turn the mixer on by the rear POWER switch and watch for the front POWER LED to come on. Your mixer is now ready to operate.

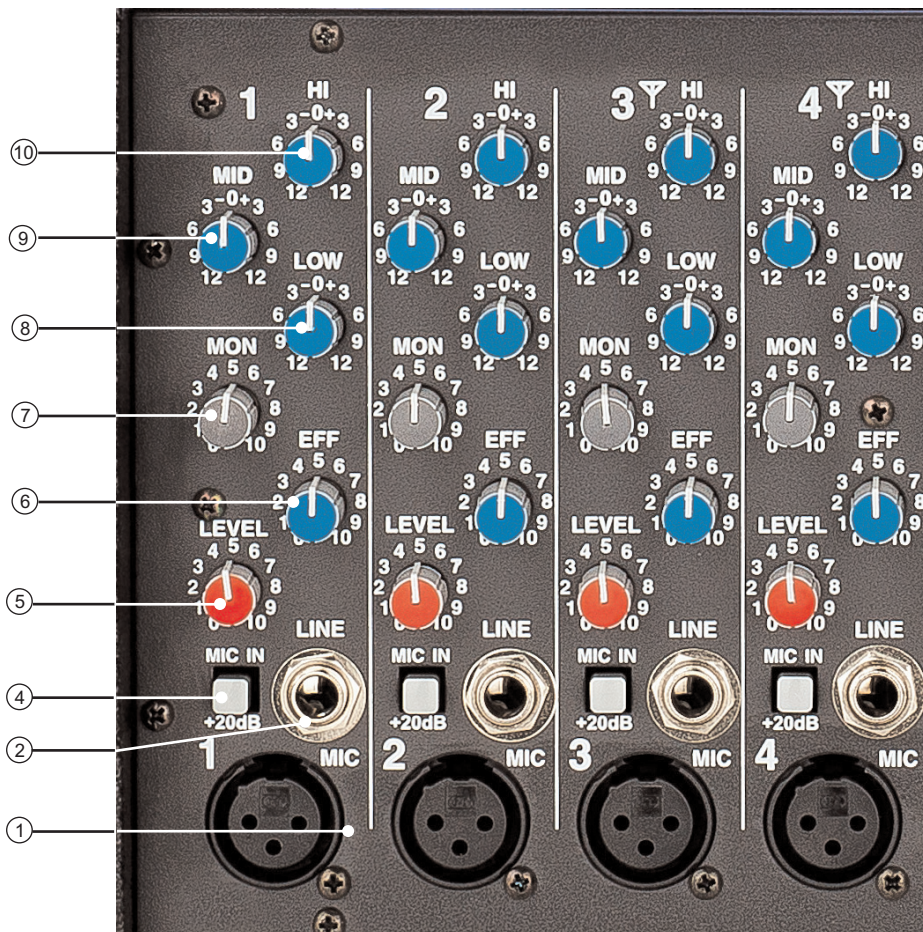

## MIC CHANNEL FEATURES

### 1. XLR MICROPHONE INPUT

The XLR MIC input is designed for balanced low impedance microphones. The high performance, low noise preamps do a superb job of noise reduction. The XLR connector is wired as per the industry standard, pin 1 is ground, pin 2 is non-inverting (positive), and pin 3 is inverting (negative). Note: Make sure the phantom power is switched off before connecting or disconnecting microphones to the mixer.

### 2. LINE INPUT JACKS (CH 1-4)

The LINE input is a 1/4" phone jack designed for balanced or unbalanced line or instruments. Examples of these inputs would be guitar, keyboard or effect returns. The line input can be used at the same time the mic input is being used.

### 3. STEREO L/R LINE IN JACKS (CH 5-8)

The LINE L and LINE R inputs on CHANNEL 5/6 and 7/8 are for connecting a MP3, CD or tape player. These RCA jacks can also be used for returning another effects processor or instrument (keyboard)

### 4. MIC IN +20DB GAIN SWITCH (CH 1-4)

The +20DB switch increases the input sensitivity on both the LINE and MIC input jacks by 20dB. After determining the input is too low for mixing with the level control, turn down the level control, press in the gain switch and adjust the level again. If distortion is heard regardless of the channel LEVEL control's setting, disengage this switch to eliminate over-driving of the input stage.

### 5. CHANNEL LEVEL CONTROL

The LEVEL control adjusts the volume of the channel before going to the MAIN level control. Here is where the individual channel volumes are adjusted to make up the desired mix at the main outputs.

### 6. CHANNEL EFFECTS LEVEL

The EFF control adjusts the level sent to the effects processor and to the front EFF SND jack. The effects control is post-channel level, which automatically tracks the channel's LEVEL & EQ controls. Reduce the EFF level if the PK LED is flashing near the main effects processor controls.

### 7. CHANNEL MONITOR CONTROL

The MON control adjusts the volume of the channel going to the master MONITOR control. The MON control is a pre-LEVEL control. This means it is unaffected by the channel LEVEL.

### 8-10. CHANNEL TONE CONTROLS

Each channel features active 3-band EQ tone controls LO, MID, and HI. All three function as boost (clockwise) & cut (counter-clockwise) controls. The center 0 is the "flat" or no effect position. The LO and HI controls are shelving type with corner frequencies at 80Hz and 11.5k Hz respectively. The MID control is a band pass type centered at 750Hz. These settings will vary with the type of voice or instrument. Try reducing the MID to add clarity and turn up the LO and HI for a fuller sound.

## MASTER SECTION FEATURES

### 11. MAIN LEVEL

The MAIN control is the master volume control for all channels. The MAIN stereo L/R signals are sent to the front LEFT OUT and RIGHT OUT jacks, and through the GRAPHIC EQ to AMP1 and AMP2 front speaker outputs (with the MAIN/MONITOR switch "IN", a combined MONO signal is sent to AMP1 only)

### 12. MONITOR LEVEL

The MONITOR signal is sent to front MON OUT jack, and with the MAIN/MONITOR switch "IN", is sent through the GRAPHIC EQ to AMP2.

### 13. MAIN LEFT/RIGHT OUTPUTS

The front LEFT OUT and RIGHT OUT are the same stereo signals that feeds the internal amps, but without the Graphic EQ. Use these 1/4" outputs to feed additional power amps, etc..

### 14. MONITOR OUTPUT

The front MON OUT is the same signal that feeds the internal amp, but without the Graphic EQ. Use this 1/4" output to feed additional power amps, in ear monitors, etc..

### 15. TAPE OUT JACKS

Use the TAPE OUT L-R jacks for recording or to send to external power amps. If the TAPE OUT is being used to record, make sure the TAPE IN jacks are not connected to the recorder output or turn the channel LEVEL to "0" or feedback will result.



### 16. DSP EFFECTS PROCESSOR

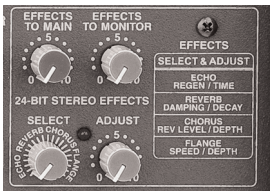

A 24-Bit processor provides a host of great sounding effects including Echo, Reverb, Chorus, and Flange.

The channel **EFF** send control delivers the signals to the processor. Note: Reduce these levels if the red PEAK LED is flashing near the main processor controls.

Turn up the **EFFECTS TO MAIN** control to add effects to the MAIN LEFT and RIGHT outputs.

Turn up the **EFFECTS TO MONITOR** control to add effects to the MONITOR outputs.

Adjust the **SELECT** and the **PARAMETER** controls to get the desired effect. Note: An audible noise will be heard while adjusting the effects.

A) **ECHO**: Turn **SELECT** for the amount of regeneration (repeats). Now turn the **PARAMETER** control for a shorter or longer delay time between the original signal and the echo.

B) **REVERB**: Turn **SELECT** for the amount of presence (high frequencies) in the reverb. Now turn the **PARAMETER** control to change the decay time of the reverb.

C) **CHORUS**: Turn **SELECT** for the amount of reverb with your chorus. Now turn the **PARAMETER** control to change the chorus depth.

D) **FLANGE**: Turn **SELECT** for the speed of your flange (phasing effect). Now turn the **PARAMETER** control to change the flange depth.

### 17. EFF SEND JACK

The **EFF SEND** jack can send a signal to an external processor. This is the same signal sent to the internal effects processor.

Effect returns can be connected to any input channel. *Make sure the **EFF** control for the return channel is set to "O" or feedback will occur.*

### 18. POWER LED

The blue **POWER LED** indicates the mixer is powered ON.

### 19. MAIN/MONITOR SWITCH - AMP ASSIGN

With the switch "IN", **AMP 1** is for MAIN (mono), and **AMP 2** is for MONITOR.

With the switch "OUT", **AMP1** and **AMP2** are in stereo for the MAIN LEFT and RIGHT speakers. The front **MON OUT** jack is unchanged by the switch setting and can be used for external power amps or in-ear monitor systems.

### 20. STEREO GRAPHIC EQ

When the EQ sliders are in their center position, they do not affect the audio signal. When EQ sliders are raised or lowered from this position, they boost or cut a narrow frequency band.

For tone enhancement you may want to raise the 80Hz and 160Hz sliders (for deeper bass) and the 6kHz and 12kHz sliders (for crisper highs) while reducing the 400Hz, 800Hz and 2kHz sliders in a moderate "curve".

To help prevent feedback, microphones should be placed behind the main speakers.

To reduce feedback in the low frequency range, try lowering one of the 80Hz or 160Hz sliders. High frequency feedback is usually reduced by lowering the 2kHz or 6kHz sliders.

### 21. USB POWER PORT

The **USB POWER PORT** allows charging of an iPod™/ MP3 player, or to power accessories such as LED lighting. Connect audio outputs from devices to the **LINE L-R** inputs on channels 5/6 or 7/8.



### 22. 48V PHANTOM POWER SWITCH / LED

The **48V PHANTOM POWER** switch turns on the microphone phantom power in the channel XLR jacks. This power is used for supplying a high voltage to condenser microphones. The **LED** indicates the phantom power is turned on. The phantom power will not damage conventional dynamic microphones. Note: Make sure the phantom power is switched off before connecting or disconnecting microphones to avoid a "pop".

### 23. SPEAKER OUTPUTS

Each amp has a 4ohms **MINIMUM IMPEDANCE** (Maximum **TWO** 8ohm speakers, OR **ONE** 4ohm speaker per AMP output jack).

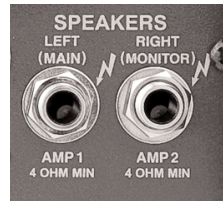

MAKE ALL SPEAKER CONNECTIONS **BEFORE** TURNING THE MIXER ON.

## REAR PANEL FEATURES:

### POWER SWITCH AND AC CONNECTOR

The rear panel contains the **POWER SWITCH** and **AC** power cable connection.

## TOP PANEL

### ACCESSORY PANEL:

The removable plate on the top panel can be replaced with the **UX600KIT** mounting bracket to connect up to two Carvin **UX600** wireless receivers. The signals from the **UX600R** receivers will be routed directly in through the mixer on Channel 3 or Channel 4.



# XP800L LIVE SET UP

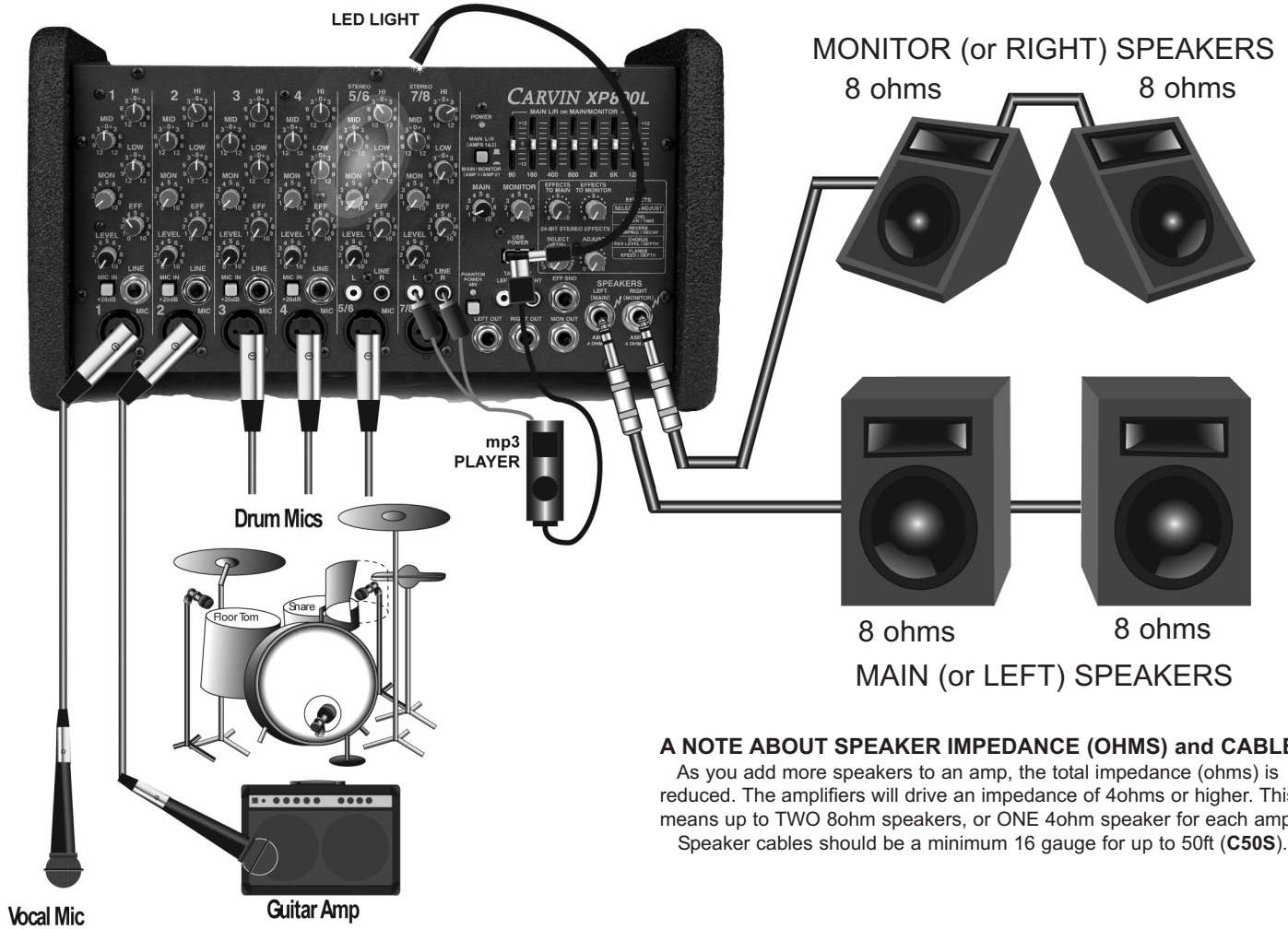

## A NOTE ABOUT SPEAKER IMPEDANCE (OHMS) and CABLES

As you add more speakers to an amp, the total impedance (ohms) is reduced. The amplifiers will drive an impedance of 4ohms or higher. This means up to TWO 8ohm speakers, or ONE 4ohm speaker for each amp. Speaker cables should be a minimum 16 gauge for up to 50ft (**C50S**).



### CAUTION

RISK OF ELECTRIC SHOCK

REFER SERVICING TO QUALIFIED SERVICE PERSONNEL!  
THIS UNIT CONTAINS HIGH VOLTAGE INSIDE!



This symbol is intended to alert the user to the presence of un-insulated "dangerous voltage" within the product's enclosure that may be of sufficient magnitude to constitute a risk of electric shock to persons.

### CAUTION

RISK OF ELECTRIC SHOCK  
DO NOT OPEN



This symbol is intended to alert the user to the presence of important operating and maintenance (servicing) instructions in the literature accompanying the appliance.



#### IMPORTANT! FOR YOUR PROTECTION, PLEASE READ THE FOLLOWING:

**WATER AND MOISTURE:** Appliance should not be used near water (near a bathtub, washbowl, kitchen sink, laundry tub, in a wet basement, or near a swimming pool, etc). Care should be taken so that objects do not fall and liquids are not spilled into the enclosure through openings.

**POWER SOURCES:** The appliance should be connected to a power supply only of the type described in the operating instructions or as marked on the appliance.

**GROUNDING OR POLARIZATION:** Precautions should be taken so that the grounding or polarization means of an appliance is not defeated.

**POWER CORD PROTECTION:** Power supply cords should be routed so that they are not likely to be walked on or pinched by items placed upon or against them, paying particular attention to cords at plugs, convenience receptacles, and the point where they exit from the appliance.

**SERVICING:** The user should not attempt to service the appliance beyond that described in the operating instructions. All other servicing should be referred to qualified service personnel.

**FUSING:** If your unit is equipped with a fuse receptacle, replace only with the same type fuse. Refer to replacement text on the unit for correct fuse type.

#### SAFETY INSTRUCTIONS (EUROPEAN)

The conductors in the AC power cord are colored in accordance with the following code.

GREEN & YELLOW—Earth BLUE—Neutral BROWN—Live

**U.K. MAIN PLUG WARNING:** A molded main plug that has been cut off from the cord is unsafe. NEVER UNDER ANY CIRCUMSTANCES SHOULD YOU INSERT A DAMAGED OR CUT MAIN PLUG INTO A POWER SOCKET.

#### LIMITED WARRANTY

Your Carvin Audio mixer is guaranteed against failure for 1 YEAR unless otherwise stated. Carvin will service and supply all parts at no charge to the customer providing the unit is under warranty. Shipping costs are the responsibility of the customer. CARVIN DOES NOT PAY FOR PARTS OR SERVICING OTHER THAN OUR OWN. A COPY OF THE ORIGINAL INVOICE IS REQUIRED TO VERIFY YOUR WARRANTY. Carvin Corp. assumes no responsibility for horn drivers or speakers damaged by this unit. This warranty does not cover, and no liability is assumed, for damage due to: natural disasters, accidents, abuse, loss of parts, lack of reasonable care, incorrect use, or failure to follow instructions. This warranty is in lieu of all other warranties, expressed or implied. No representative or person is authorized to represent or assume for Carvin Corp. any liability in connection with the sale or servicing of Carvin products. CARVIN CORP. SHALL NOT BE LIABLE FOR INCIDENTAL OR CONSEQUENTIAL DAMAGES.

#### MAINTAINING YOUR EQUIPMENT

Avoid spilling liquids or allowing any other foreign matter inside the unit. The panel of your unit can be wiped with a dry or slightly damp cloth in order to remove dust and bring back the new look. As with all pro gear, avoid prolonged use in caustic environments (salt air). When used in such an environment, be sure the amplifier is adequately protected.

#### SERVICE

In the USA go to [www.carvinaudio.com](http://www.carvinaudio.com).

Outside the USA, contact your dealer or go to [www.carvinaudio.com](http://www.carvinaudio.com) and click on "Dealers" for your nearest service center. Include a written description of the problem with serial number and date of purchase.