



The **XP1000L** mixer is Carvin's new design to eliminate the plastic case and to offer more efficient power amps with greater tonal quality. The 3 Class D power amps are 95% efficient conserving power so they are more environmentally friendly allowing the use of small portable generators.

SUPERB SOUND is derived from the extremely low distortion, "high headroom" design. State-of-the-art, low noise, balanced XLR preamps from our Concert Series mixers provide common mode rejection better than 78 dB, which means that any noise that may come over your cables is virtually eliminated. Distortion is nearly non-existent with THD below 0.1% from input to output, guaranteeing the purity of your sound. Hear the difference.

LIGHTWEIGHT and EASY TO USE Controls are logically laid out making the XP Series simple to use reducing errors during setup and performance. Its compact size and weight of only 15 lbs. makes it the lightest, most powerful mixer in its class.

3 HIGH CURRENT "GREEN" CLASS-D AMPLIFIERS produce total of 1200w RMS, 1600w peak. Class D amps not only run cooler, but their power capabilities are outstanding. The main L and R delivers 800w RMS (400w/400w) and the Monitor output delivers another 400w RMS - this kind of power maintains sonic purity while eliminating outboard power amps. Speaker outputs accept either standard 1/4" or Speakon™ connectors for secure connections with maximum power transfer to your speakers. Output meters and clip LED's give you a visual indicator for each amp.

HIGH CURRENT "GREEN" SWITCHMODE POWER SUPPLY conserves power by operating at high efficiency. The DC voltage supply is recharged 100,000 times per second, delivering continuous high current to the power amps.

2 INDEPENDENT 24-Bit STEREO DSP EFFECTS allow you to assign each channel to your choice of effects. You can dedicate chorus/reverb to the acoustic guitar channel and a lush reverb to the vocals, etc. Both effects are adjustable to your stage monitors so you can hear yourself with full effects. The effects processors with 256 effects each include reverbs, choruses, flanging and echoes with fully adjustable parameters for damping, decay, depth, speed, regeneration and time.

ACTIVE 3 BAND CHANNEL EQ provides easy adjustment for the tone you want. The 80Hz LO frequency control delivers a solid non-flabby bass. A simple adjustment with the MID band control brings out the best sound for vocals or guitar by affecting the very important 750Hz frequency range. The 11.5k Hz HI treble control adds sparkle to your top-end without adding harshness. Both the LO and HI controls are "shelving", which means they are effective from 20Hz to 20kHz.

THREE 7-BAND EQUALIZERS provide precise adjustments to fine tune your overall sound and to help control feedback. A stereo (dual) graphic equalizer controls the main L and R outputs and a mono equalizer controls the monitor output.

ENGINEERED TO LAST Every XP Series mixer incorporates a rugged steel chassis with protective side panels. Continuous full power is assured from high-grade 6063-T5-aluminum heat sinks cooled by a variable speed fan. Sealed controls and switches guard against the outside elements while heavy-duty connectors provide a positive connection to your cables. Hidden deep in the heart of these mixers is the "SMT" Surface Mount Technology that utilizes surface mounted components to prevent parts from shaking or vibrating loose. Precision 1% tolerances guarantee your settings will be accurate every time. Fire retardant FR-4 military spec circuit cards feature double-sided copper to guard against noise and radio frequencies (RF). The XP series mixers are solidly built for years of dependable service!



RECEIVING INSPECTION—read before getting started

INSPECT YOUR MIXER FOR DAMAGE which may have occurred during shipping. If damage is found, please notify the shipping company and CARVIN immediately.

SAVE THE CARTON & ALL PACKING MATERIALS. In the event you have to re-ship your unit, always use the original carton and packing material. This will provide the best possible protection during shipment. CARVIN and the shipping company are not liable for any damage caused by improper packing.

SAVE YOUR INVOICE. It will be required for warranty service if needed in the future.

SHIPMENT SHORTAGE. If you find items missing, they may have been shipped separately. Please allow several days for the rest of your order to arrive before inquiring.

RECORD THE SERIAL NUMBER on the enclosed warranty card or below on this manual for your records. Keep your portion of the card and return the portion with your name and comments to us.

For your records, you may wish to record the following information.

Serial No. _____ Invoice Date _____

XP1000L BLOCK DIAGRAM

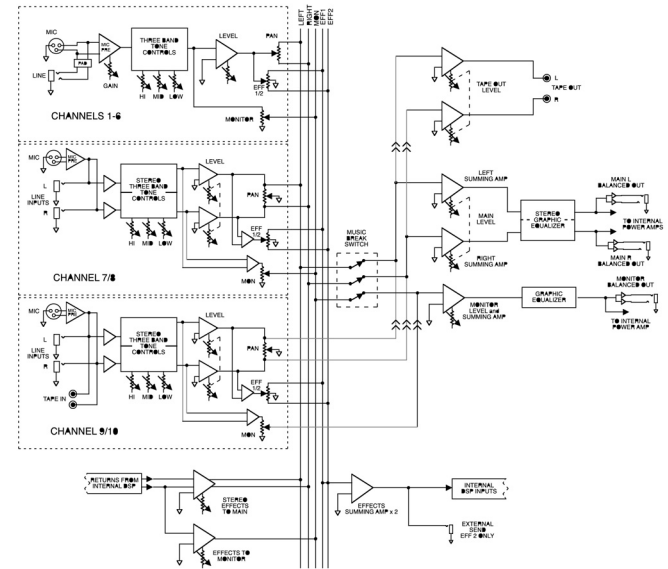

MODEL XP1000L SPECIFICATIONS:

Frequency Response:	Mic or Line Inputs: 20Hz-20kHz ±1dB
Total Harmonic Distortion:	Less than .1% at nominal levels
Equivalent Input Noise:	150 ohm source: -117dBu
Output Noise:	-90dBu Master Line Out (All Levels Minimum)
Output Headroom:	+20dB
Maximum Gain:	Mic in to Master Line Out: 70dB
Crosstalk:	Adjacent ch's: -60db at 1KHz
Common Mode Rejection:	-78db at 1KHz
Phantom Power:	48 volt @ XLR Mic channels
USB Power port:	5 volt, 200mA for LED lighting or MP3 charging
Channel EQ 3-band active:	LOW: 80Hz ±12dB MID: 750Hz ±12dB HI: 11.5KHz ±12dB
Power Output:	1200w (3x400w@4ohms)
Power Req.:	100-140VAC or 200-250VAC, 50-60Hz
Size and Weight:	10.3"H x 17"W x 10"D, 15 lbs
Accessories:	UX600R wireless receiver (requires UX600KIT) UX600KIT mounting bracket for up to two UX600R FS22 footswitch for effects on/off CV1000 Vinyl Cover



CARVIN

AUDIO • AMPLIFIERS

16262 WEST BERNARDO DR. SAN DIEGO, CA 92127
www.carvinaudio.com

XP1000L CONTROLS

Quick Start Up

If you're like most new owners, you're probably in a hurry to plug your mixer in and use it. Here are some brief instructions to get you going quickly. With the mixer unplugged and the unit turned off, complete the following procedures:

A. CONNECTING AC POWER TO YOUR MIXER

- Start by plugging in your mixer. It will automatically select 120V-60Hz or 240V-50Hz.
- Use only a grounded (3 prong) power outlet to prevent a shock hazard (do not bypass). This gives the quietest grounding for your mixer.

B. CONNECTING INPUTS TO YOUR MIXER

- For microphones, use a XLR shielded cable and plug into the XLR MIC inputs.
- For high output devices like instruments & keyboards, plug into the LINE input jacks using a shielded cable. Adjust the channel GAIN control for mic or for instrument.

C. TURNING YOUR MIXER ON

- Set all Channel and Master LEVEL controls to their OFF positions.
- Set all HI, MID, and LOW controls and the GRAPHIC EQUALIZERS to the center "flat - no boost or cut" position.
- Adjust all "BAL" controls to their center position.
- Connect your speakers and monitors at the rear panel.
- Turn the mixer on by the rear POWER SWITCH and watch for the front POWER LED to come on. Your mixer is now ready to operate by gradually turning up the levels.

MIC CHANNEL FEATURES

1. XLR MICROPHONE INPUT

The XLR MIC input is designed for balanced low impedance microphones. The high performance, low noise preamps do a superb job of noise reduction. The XLR connector is wired as per the industry standard, pin 1 is ground, pin 2 is non-inverting (positive), and pin 3 is inverting (negative). Note: Make sure the +48v phantom power is switched off before connecting or disconnecting microphones to the mixer.

2. LINE INPUT JACKS

The LINE input is a 1/4" phone jack designed for balanced or unbalanced line or instruments. Examples of these inputs would be guitar, keyboard or effect returns. The line input can be used at the same time the mic input is being used. Channels 7/8 and 9/10 feature stereo LINE INPUTS for stereo (use the top jack for mono input).

3. GAIN CONTROL (CHANNELS 1-6)

The GAIN control adjusts the input sensitivity on both the LINE and MIC input jacks over a range of 40dB. For quietest operation, set the GAIN control just below the point where the PK LED flashes. If the PK LED lights or if distortion is heard, reduce the GAIN slightly until the PK LED is off.

4. CHANNEL "PK" LED

The PK LED indicates when the channel is nearing its clipping level, causing distortion. Reduce the GAIN slightly to prevent distortion. On channels 7/8 and 9/10, reduce the level from your external source. To get more volume, increase the master MAIN control and re-adjust your main mix.

5. CHANNEL LEVEL CONTROL

The LEVEL control adjusts the volume of the channel before going to the BALANCE control. Here is where the individual channel volumes are adjusted to make up the desired mix at the main outputs.

6. CHANNEL BALANCE CONTROL

The BAL control places the channel between Left and Right in the main stereo outputs. At the "0" center setting, the channel will be heard equally from the Left and Right outputs.

When both 1/4" jacks are used on channels 7/8 or 9/10, the BAL adjusts the L-R levels, sending signals from LINE 7/9 to the LEFT, and signals from LINE 8/10 to the RIGHT.

7. CHANNEL EFFECTS 1&2 LEVEL

The EFF 1&2 adjusts the level sent to the dual effects processor and to the front EFF SND 2 jack. The effects control is post-channel level, which automatically tracks the channel's LEVEL &

TONE controls. Turning this control to the left will send to the internal effects processor EFF1. Turning to the right will send to the internal effects processor EFF2 (and the external EFF 2 SND jack). Center "0" is off. Reduce these levels if the PK LEDs are flashing on the effects processors.

8. CHANNEL MONITOR CONTROL

The MON control adjusts the volume of the channel going to the master MONITOR control. The MON control is a pre-LEVEL control. This means it is unaffected by the channel LEVEL.

9-11. CHANNEL TONE CONTROLS

Each channel features active 3-band EQ tone controls LOW, MID, and HI. All three function as boost (clockwise) & cut (counter-clockwise) controls. The center 0 is the "flat" or no effect position. The LOW and HI controls are shelving type with corner frequencies at 80Hz and 11.5k Hz respectively. The MID control is a band pass type centered at 750Hz. Your settings will vary with the type of voice or instrument. Try reducing the MID to add clarity and turn up the LOW and HI for a fuller sound. Channels 7/8 and 9/10 feature stereo TONE controls.

16. TAPE OUT JACKS

Use the TAPE OUT L/R jacks for recording or to send to external power amps. If the TAPE OUT is being used to record, make sure the TAPE IN jacks are not connected to the recorder output or turn the channel 9/10 LEVEL to "0" or feedback will result.

17. EFF 2 SEND JACK

The EFF 2 SEND jack can send a signal to an external processor. This is the same signal sent to the internal EFF 2 processor. Effect returns can be connected to any input channel. Make sure the EFF control for the return channel is set to "OFF" or "EFF1" or feedback will occur.

18. MAIN L-R OUTPUTS

The MAIN L/R outputs are the same signals that feed the internal LEFT and RIGHT amps. Use these balanced 1/4" outputs to feed additional power amps, etc..

19. MONITOR OUTPUT

The MONITOR output is the same signal that feeds the internal MONITOR amp. Use this balanced output to feed additional power amps, etc..

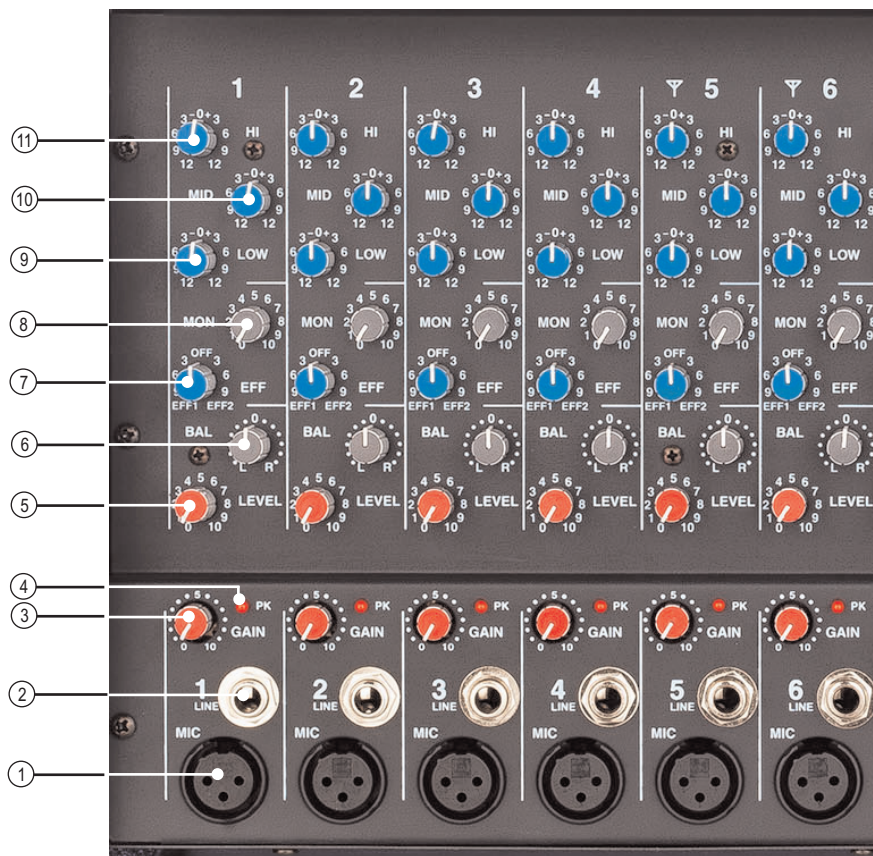

12. TAPE IN JACKS (CHANNEL 9/10)

The L-R TAPE IN inputs on CHANNEL 9/10 are for connecting an iPod™/MP3 or CD. These TAPE IN jacks can be used for returning another stereo effects processor or instrument (keyboard). Channel 9/10 inputs are NOT muted by the MUSIC BREAK switch allowing you to have background music while everything else is turned off.

MASTER SECTION FEATURES

13. MAIN LEVEL (L & R AMPS)

The MAIN control is the master volume control for all channels. The MAIN signal is sent through the MAIN L-R GRAPHIC EQ to the L and R amps and the front L/R output jacks which can be used for additional power amps, etc.

14. MONITOR LEVEL (MONITOR AMP)

The MONITOR master level is sent through the MONITOR GRAPHIC EQ to the MONITOR amp and front output jack.

15. TAPE OUT LEVEL

The TAPE OUT LEVEL sends the MAIN signal mix to the TAPE OUT jacks for recording. The TAPE OUT level is unaffected by the MAIN level control so a recording level can be set independently of the MAIN speaker volume.

20. DUAL EFFECT PROCESSORS

Two 24-BIT processors provide a host of great sounding effects including Flange, Reverb, Echo, & Chorus.

The channel EFF 1 & 2 send control delivers the signals to the processors. Note: Reduce these levels if the red PEAK LEDs are flashing at the processors.

Turn up the MAIN EFFECTS control to add your effects to the L-R outputs. Adjust the SELECT and the PARAMETER to get the desired effect. Note: An audible noise will be heard while adjusting the effects.

A) ECHO: Turn SELECT for the amount of regeneration (repeats). Now turn the PARAMETER control for a shorter or longer delay time between the original signal and the echo.

B) REVERB: Turn SELECT for the amount of presence (high frequencies) in the reverb. Now turn the PARAMETER control to change the reverb decay time.

C) CHORUS: Turn SELECT for the amount of reverb with your chorus. Now turn the PARAMETER control to change the chorus depth.

D) FLANGE: Turn SELECT for your speed (phasing effect). Now turn the PARAMETER control to change the flange depth.

21. EFFECTS PEAK LED's

The PK LEDs indicate that the signal level to the processor is too high. To prevent distortion, turn the **EFF 1 & 2** control towards the center (off) position until the PK LED stops flashing.

22. MAIN EFFECTS CONTROL

The MAIN EFFECTS level controls the amount of the effects that go to your MAIN L/R outputs.

23. MONITOR EFFECTS LEVEL

The MONITOR EFFECTS level controls the amount of the effects that go to your MONITORS.

24. MUSIC BREAK SWITCH

The MUSIC BREAK feature turns off all inputs, except for channel 9/10. This is useful during breaks. This allows pre-recorded music to be played through the TAPE IN jacks. The channel 9/10 MIC/LINE inputs are left active for announcements or solo acts. The remaining input channels (1-8) are turned OFF eliminating feedback or other unwanted sounds from open mics during breaks or changes. The internal effects are also muted.

27. POWER LED

The blue POWER LED indicates the mixer is powered ON.

28. PROTECT LED

The mixer will "protect", engaging circuits to mute the speakers if: a) impedance is below minimum on any amp, b) shorted speaker cables, or c) ventilation problems. If the LED comes on, shut the mixer OFF and check for cable problems, minimum impedances and obstructed rear cooling vents. If you encounter an over-heat problem, leave the mixer ON allowing the fan to cool down the internal components. The mixer will auto-reset in about 5 minutes.

29. USB POWER PORT

The USB POWER PORT allows charging of an iPod™/ MP3 player or to power accessories such as LED lighting. You may use a USB splitter but it is limited to 200mA driving power several devices. Connect iPod™/ MP3 outputs to TAPE IN.

REAR PANEL

AC POWER:

The rear panel contains the POWER SWITCH and AC power cable connection.

SPEAKER CONNECTIONS:

The 3 speaker jacks will accept 1/4" or high-current Speakon™ connectors. Each amp output has a 4 OHM MINIMUM IMPEDANCE. (Maximum one 4ohm or two 8ohm speakers per amp). If using Speakon™ cables, be sure to push the lock back, turning to the right for a secure locked connection.

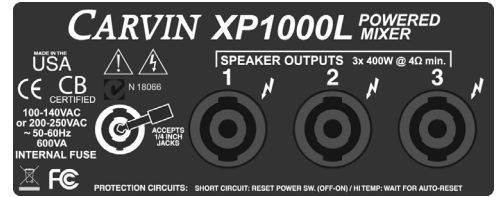

MAKE ALL SPEAKER CONNECTIONS BEFORE TURNING THE MIXER ON.

TOP PANEL

ACCESSORY PANEL:

The removable plate on the top panel can be removed to connect up to two Carvin UX600 wireless receivers using the UX600KIT mounting bracket. The signals from the UX600Rs will be routed directly in through the mixer on Channel 5 or Channel 6.

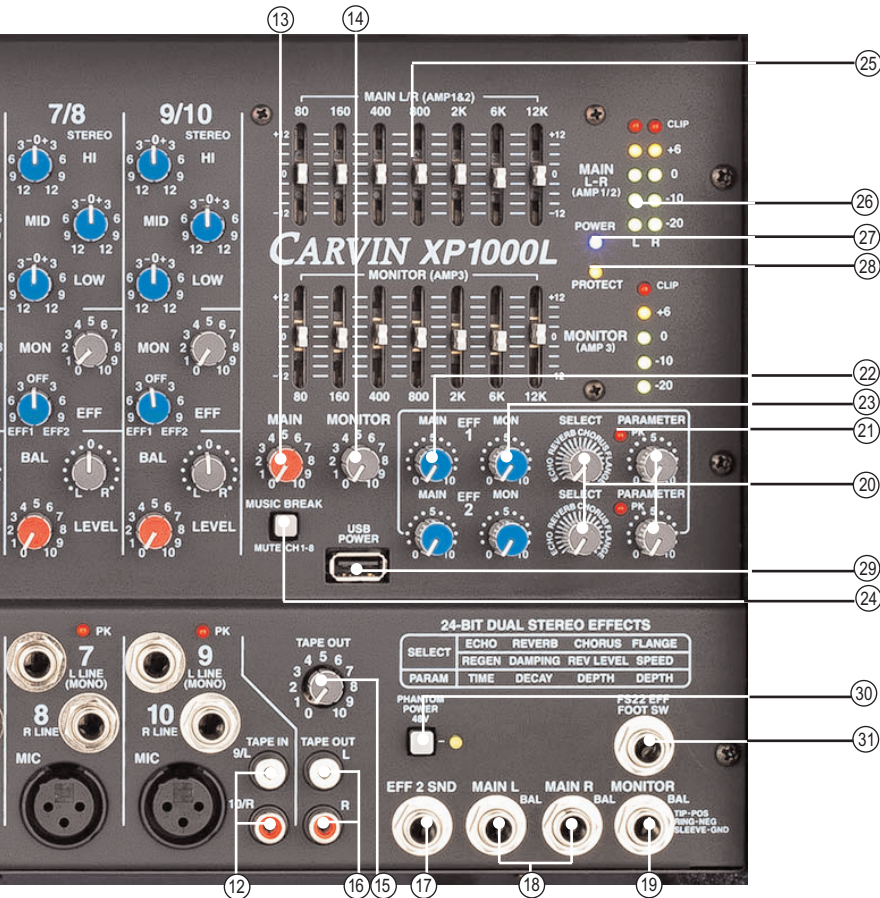

25. GRAPHIC EQ L/R + MONITOR

When the EQ sliders are in their center position, they do not affect the audio signal. When EQ sliders are raised or lowered from this position, they boost or cut a narrow portion of the frequency band. For tone enhancement you may want to raise the 80Hz and 160Hz sliders (for deeper bass) and the 6kHz and 12kHz sliders (for crisper highs) while reducing the 400Hz, 800Hz and 2kHz sliders in a moderate "curve".

To help prevent feedback, microphones should be placed behind the main speakers. To reduce feedback in the low frequency range, try lowering one of the 80Hz or 160Hz sliders. High frequency feedback is usually reduced by lowering the 2kHz or 6kHz sliders.

26. OUTPUT LED's/AMP "CLIP" LED's

The OUTPUT METER LEDs indicate the output levels for each power amp. The yellow "+6" LED indicates the output level is near maximum. The red CLIP LEDs indicate when the power amps are starting to distort (clip). Reduce the MAIN and/or MONITOR master levels to prevent distortion.

30. 48V PHANTOM POWER SWITCH/LED

The 48V PHANTOM POWER switch turns on the microphone phantom power in the channel XLR jacks. This power is used for supplying a high voltage to condenser microphones. The LED indicates the phantom power is turned on. The phantom power will not damage conventional dynamic microphones. Note: Make sure the phantom power is switched off before connecting or disconnecting microphones to avoid a "pop".

31. EFFECTS FOOT SWITCH JACK

The optional FS22 will remotely shut off EFFECTS 1 or 2.

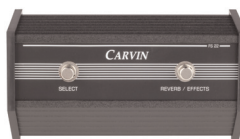

XP1000L LIVE SET UP

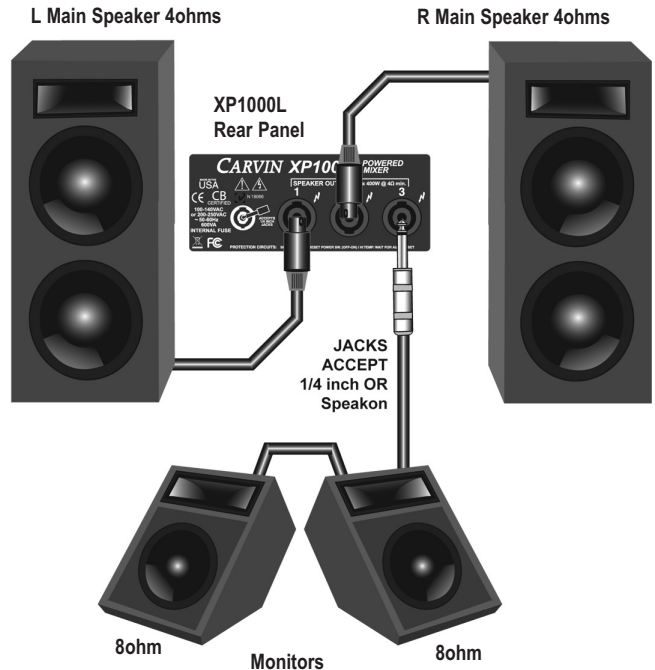
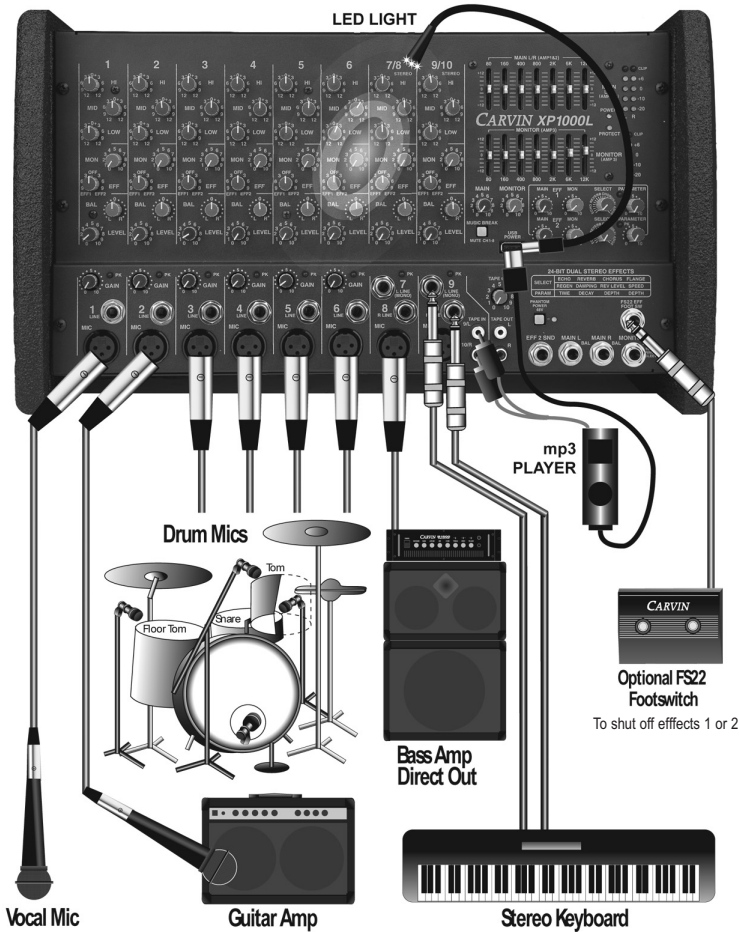

A NOTE ABOUT SPEAKER IMPEDANCE (OHMS) and CABLES

As you add more speakers, the total impedance (ohms) is reduced by half. Each amplifier will drive an impedance of 4ohms or higher. This means up to two 8ohm speakers or one 4ohm speaker per each amp. If the protect LED comes on, this could mean you are below the recommended 4ohms for each amp.

Speaker cables should be a minimum 16 gauge for up to 50ft (C50S). Heavy-duty Speakon™ 12 gauge cables (PRO100TL) are recommended for lengths over 50ft.



CAUTION
RISK OF ELECTRIC SHOCK

REFER SERVICING TO QUALIFIED SERVICE PERSONNEL!
THIS UNIT CONTAINS HIGH VOLTAGE INSIDE!

 This symbol is intended to alert the user to the presence of uninsulated "dangerous voltage" within the product's enclosure that may be of sufficient magnitude to constitute a risk of electric shock to persons.

CAUTION
RISK OF ELECTRIC SHOCK
DO NOT OPEN

This symbol is intended to alert the user to the presence of important operating and maintenance (servicing) instructions in the literature accompanying the appliance. 

IMPORTANT! FOR YOUR PROTECTION, PLEASE READ THE FOLLOWING:

WATER AND MOISTURE: Appliance should not be used near water (near a bathtub, washbowl, kitchen sink, laundry tub, in a wet basement, or near a swimming pool, etc). Care should be taken so that objects do not fall and liquids are not spilled into the enclosure through openings.

POWER SOURCES: The appliance should be connected to a power supply only of the type described in the operating instructions or as marked on the appliance.

GROUNDING OR POLARIZATION: Precautions should be taken so that the grounding or polarization means of an appliance is not defeated.

POWER CORD PROTECTION: Power supply cords should be routed so that they are not likely to be walked on or pinched by items placed upon or against them, paying particular attention to cords at plugs, convenience receptacles, and the point where they exit from the appliance.

SERVICING: The user should not attempt to service the appliance beyond that described in the operating instructions. All other servicing should be referred to qualified service personnel.

FUSING: If your unit is equipped with a fuse receptacle, replace only with the same type fuse. Refer to replacement text on the unit for correct fuse type.

SAFETY INSTRUCTIONS (EUROPEAN)

The conductors in the AC power cord are colored in accordance with the following code.
GREEN & YELLOW—Earth BLUE—Neutral BROWN—Live

U.K. MAIN PLUG WARNING: A molded main plug that has been cut off from the cord is unsafe. NEVER UNDER ANY CIRCUMSTANCES SHOULD YOU INSERT A DAMAGED OR CUT MAIN PLUG INTO A POWER SOCKET.

LIMITED WARRANTY

Your Carvin Audio mixer is guaranteed against failure for 1 YEAR unless otherwise stated. Carvin will service and supply all parts at no charge to the customer providing the unit is under warranty. Shipping costs are the responsibility of the customer. CARVIN DOES NOT PAY FOR PARTS OR SERVICING OTHER THAN OUR OWN. A COPY OF THE ORIGINAL INVOICE IS REQUIRED TO VERIFY YOUR WARRANTY. Carvin Corp. assumes no responsibility for horn drivers or speakers damaged by this unit. This warranty does not cover, and no liability is assumed, for damage due to: natural disasters, accidents, abuse, loss of parts, lack of reasonable care, incorrect use, or failure to follow instructions. This warranty is in lieu of all other warranties, expressed or implied. No representative or person is authorized to represent or assume for Carvin Corp. any liability in connection with the sale or servicing of Carvin products. CARVIN CORP. SHALL NOT BE LIABLE FOR INCIDENTAL OR CONSEQUENTIAL DAMAGES.

MAINTAINING YOUR EQUIPMENT

Avoid spilling liquids or allowing any other foreign matter inside the unit. The panel of your unit can be wiped with a dry or slightly damp cloth in order to remove dust and bring back the new look. As with all pro gear, avoid prolonged use in caustic environments (salt air). When used in such an environment, be sure the amplifier is adequately protected.

SERVICE

In the USA go to www.carvinaudio.com.

Outside the USA, contact your dealer or go to www.carvinaudio.com and click on "Dealers" for your nearest service center. Include a written description of the problem with serial number and date of purchase.