

This symbol is intended to alert the user to the presence of uninsulated "dangerous voltage" within the product's enclosure that may be of sufficient magnitude to constitute a risk of electric shock to persons.

CAUTION
RISK OF ELECTRIC SHOCK
DO NOT OPEN

This symbol is intended to alert the user to the presence of important operating and maintenance (servicing) instructions in the literature accompanying the appliance.

IMPORTANT! FOR YOUR PROTECTION, PLEASE READ THE FOLLOWING:
WATER AND MOISTURE: Appliance should not be used near water (near a bathtub, washbowl, kitchen sink, laundry tub, in a wet basement, or near a swimming pool, etc). Care should be taken so that objects do not fall and liquids are not spilled into the enclosure through openings.

POWER SOURCES: The appliance should be connected to a power supply only of the type described in the operating instructions or as marked on the appliance.

GROUNDING OR POLARIZATION: Precautions should be taken so that the grounding or polarization means of an appliance is not defeated.

POWER CORD PROTECTION: Power supply cords should be routed so that they are not likely to be walked on or pinched by items placed upon or against them, paying particular attention to cords at plugs, convenience receptacles, and the point where they exit from the appliance.

SERVICING: The user should not attempt to service the appliance beyond that described in the operating instructions. All other servicing should be referred to qualified service personnel.

FUSING: If your unit is equipped with a fuse receptacle, replace only with the same type fuse. Refer to replacement text on the unit for correct fuse type.

SAFETY INSTRUCTIONS (EUROPEAN)
The conductors in the AC power cord are colored in accordance with the following code.
GREEN & YELLOW—Earth BLUE—Neutral BROWN—Live
U.K. MAIN PLUG WARNING: A molded main plug that has been cut off from the cord is unsafe. NEVER UNDER ANY CIRCUMSTANCES SHOULD YOU INSERT A DAMAGED OR CUT MAIN PLUG INTO A POWER SOCKET.

LIMITED WARRANTY
Your Carvin product is guaranteed against failure for 1 YEAR unless otherwise stated. Carvin will service and supply all parts at no charge to the customer providing the unit is under warranty. Shipping costs are the responsibility of the customer. CARVIN DOES NOT PAY FOR PARTS OR SERVICING OTHER THAN OUR OWN. A COPY OF THE ORIGINAL INVOICE IS REQUIRED TO VERIFY YOUR WARRANTY. Carvin assumes no responsibility for horn drivers or speakers damaged by this unit. This warranty does not cover, and no liability is assumed, for damage due to: natural disasters, accidents, abuse, loss of parts, lack of reasonable care, incorrect use, or failure to follow instructions. This warranty is in lieu of all other warranties, expressed or implied. No representative or person is authorized to represent or assume for Carvin any liability in connection with the sale or servicing of Carvin products. CARVIN SHALL NOT BE LIABLE FOR INCIDENTAL OR CONSEQUENTIAL DAMAGES.

When RETURNING merchandise to the factory, you may call for a return authorization number. Describe in writing each problem. If your unit is out of warranty, you will be charged the current FLAT RATE for parts and labor to bring your unit up to factory specifications.

MAINTAINING YOUR EQUIPMENT
Avoid spilling liquids or allowing any other foreign matter inside the unit. The panel of your unit can be wiped from time to time with a dry or slightly damp cloth in order to remove dust and bring back the new look. As with all pro gear, avoid prolonged use in caustic environments (salt air). When used in such an environment, be sure the mixer is adequately protected by a cover.

REPLACEMENT PARTS LIST (for circuit cards)

Table with 3 columns: Part Number, Description, and Quantity. Includes parts like D6 03-50135, S1 06-40040, J11 21-40000, etc.

CAUTION
RISK OF ELECTRIC SHOCK

REFER SERVICING TO QUALIFIED SERVICE PERSONNEL! THIS UNIT CONTAINS HIGH VOLTAGE INSIDE!

Table with 3 columns: Part Number, Description, and Quantity. Includes parts like "R111, R131, R133, R136, R150, R158.", "R50, R90", "R77, R82, R161, R162, R177, R178, R233", etc.

Table with 3 columns: Part Number, Description, and Quantity. Includes parts like D1 60-75330, D2 60-75340, Q27 60-78050, etc.



PA620

Congratulations on your purchase of the PA410 or PA620 mixer! These mixers are the culmination of Carvin's 50 years of knowledge and experience in the pro sound arena. The quality and features included in these powerful little units make them revolutionary and unheard of in their price range! Please take the time to review this manual so that you may fully enjoy all the benefits your mixer has to offer.

PRO FEATURES

The PA series mixers give you pro XLR mic preamps, along with 1/4" line inputs on every channel. Phantom power is provided on the XLR inputs for compatibility with high quality condenser mics. Each channel also provides a MONITOR send, a GAIN switch for accommodating low and high input signals, EFFECTS send and LEVEL control.

ACTIVE EQ

Each channel of the PA series provides a HI and LOW shelving EQ with ±12dB of adjustment range featuring an internally optimized midrange circuit, for easy, effective tone adjustments that sound great for vocals.

BUILT-IN POWER AMPS

The amplifiers in the PA series mixers are powerful enough to easily drive your speakers for excellent coverage and clean, punchy sound. The PA410 delivers 100 Watts RMS, while the more powerful PA620 delivers 200 Watts RMS! (Note: Each model is designed to be used with 8Ω speakers (not 4 Ω). If the relay protection engages after 20 minutes of heavy use (no output from the mixer while the power LED is on), you are using 4Ω speakers. If the mixer goes into protect, let the mixer cool down and it will reset).

24-BIT DIGITAL PROCESSOR

Perhaps the most incredible feature of the PA series mixer is the "Full-Featured" 24-Bit Digital Processor. You get awesome lush Reverbs, rich Chorus, crisp Delay and Echo, and thick, layered Flanging – all with full band-width and pristine clarity. And with the PARAMETER control, you can continuously modify each effect for up to 64 different sounds for a total of 256 effects! Nobody else has offered these features in a mixer in this price range!

PA410 / PA620 BLOCK DIAGRAM

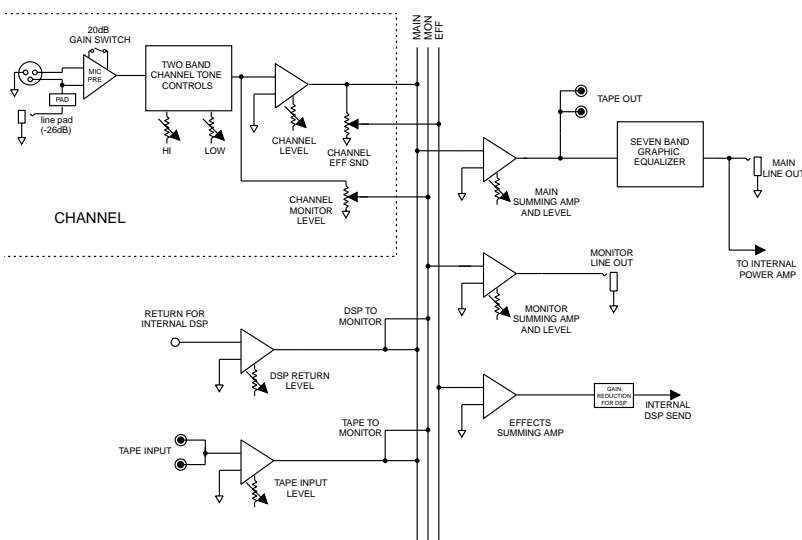

MASTER SECTION

The master section of the PA series provides a MAIN volume for controlling your over-all mix volume. A master MONITOR knob lets you control the over-all volume of an external monitor amp. The TAPE IN control is for varying the level of the signal being received at the RCA TAPE IN jacks. A PHANTOM POWER switch is provided for engaging or disengaging power to condenser mics. Three controls EFFECT, SELECT, and PARAMETER, are for setting up the full-featured Digital Effects. Finally, there is a master 7-Band GRAPHIC EQ for fine tuning your over-all mix. It's so easy to get a great sound!

CONNECTIVITY

The PA series mixers allow easy connections to most related equipment. There is a 1/4" MAIN LINE OUT for sending the main signal to an external power amp or for plugging in headphones. The MONITOR OUT is a 1/4" jack for feeding an external monitor amplifier. RCA TAPE IN and OUT are provided for easy connection to keyboards, tape decks, CD players, MiniDisc, computers, etc. The EFFECTS FOOT SW jack allows the connection of the optional FS22 or equivalent footswitch for turning on or off your effects during performances. Two 1/4" SPEAKER jacks provide quick, easy connection for two 8 Ohm speakers.

CONSTRUCTION

Solid plywood construction, space-age aluminum chassis and a modern power supply all add up to make the PA series the best-built and most lightweight, compact pro mixers available. Technical advances like SMT (surface mount components) and incredible 24-Bit DSP ensure that they are the best sounding and most reliable compact mixers as well.

RECEIVING INSPECTION—read before getting started

INSPECT YOUR MIXER FOR ANY DAMAGE which may have occurred during shipping. If any damage is found, please notify the shipping company and CARVIN immediately. SAVE THE CARTON & ALL PACKING MATERIALS. In the event you have to re-ship your unit, always use the original carton and packing material. This will provide the best possible protection during shipment. CARVIN and the shipping company are not liable for any damage caused by improper packing.

SAVE YOUR INVOICE. It will be required for warranty service if needed in the future. SHIPMENT SHORTAGE. If you find items missing, they may have been shipped separately. Please allow several days for the rest of your order to arrive before inquiring.

RECORD THE SERIAL NUMBER on the enclosed warranty card or below on this manual for your records. Keep your portion of the card and return the portion with your name and comments to us or register online at www.carvin.com/registration

For your records, you may wish to record the following information.

Serial No. _____ Invoice Date _____

PA410 / PA620 SPECIFICATIONS:

- Frequency Response:** 20Hz-20KHz ±1dB
- Total Harmonic Distortion:** Less than 1%
- Equivalent Input Noise:** 150 ohm source: -110dBu
- Output Noise:** -90dBu Master Line Out (all levels minimum)
- Output Power:** PA410 4Ω: 100 watts RMS
PA620 4Ω: 200 watts RMS
- Output Headroom:** +20dB 1/4" unbalanced
- Maximum Gain:** Mic in to Master Line Out: 65dB
- Crosstalk:** Adjacent ch's: -60db at 1KHz
- Common Mode Rejection:** -75db at 1KHz
- Phantom Power:** All XLR Mic in channels
- Channel EQ.:** HI: 12KHz ±15dB
LOW: 85Hz ±15dB
- Graphic EQ.:** 7 Band Oct. Intervals ±12dB
100, 250, 1k, 2.5k, 5k, 10k
- Mic Input:** Unbalanced 1/4" Phone Jack
- Line Input:** PA410 120 or 240 VAC - 110VA
PA620 120 or 240 VAC - 220VA
- Power Requirements:** 16"W x 8"D x 8.25"H
- Size:** PA410: 15lbs., PA620: 18lbs
- Weight:** FS22 Footswitch, CV620 cover
- Options:**



12340 World Trade Drive, San Diego, CA 92128
800.854.2235 www.carvin.com

LIVE SOUND SYSTEM

In a live sound reinforcement or a public address system (P.A. System), the input signals to the mixer will come from the microphones and instruments on the stage. Each microphone or instrument to be amplified by the P.A. system must be connected to one of the mixer's inputs. If you have enough channels, try to mic each stage instrument. This allows for the best overall sound control of the instruments as they are mixed together and then amplified by the P.A. system. This will also provide the ability to record your performance with all instruments in the mix via the TAPE OUT RCA jacks.

THE SOUND CHECK

The sound check takes some skill, but mostly patience from the performers and especially you the system operator. If you get frustrated during the sound check the performers can lose confidence and the sound may suffer due to things missed in the sound check. The basic sound check follows this format: First test all micro-

phones and other input devices (direct boxes, etc.) before the performers are included in the sound check. A good thing to also check here is feedback in the monitors from the microphones. Good positioning of the monitors and the use of the graphic equalizer solves most major monitor feedback problems. Now for a sound check with the performers. First set the level of each performer individually and in cases where a performer has multiple microphones, such as with a drummer, set each drum mic individually then the drum set as a whole. This is also a good time to make some channel tone control adjustments to tailor the sound of the individual performers and instruments. Next after setting each individual, have the performers run through a song or a portion of the show. Don't hesitate to stop the performers if something needs to be adjusted or if an individual performer or microphone needs to be heard solo again. Remember the sound check is not a rehearsal, but a system check, a time to work the bugs out of the system so the show can go smoothly.

DSP EFFECTS FOOTSWITCH

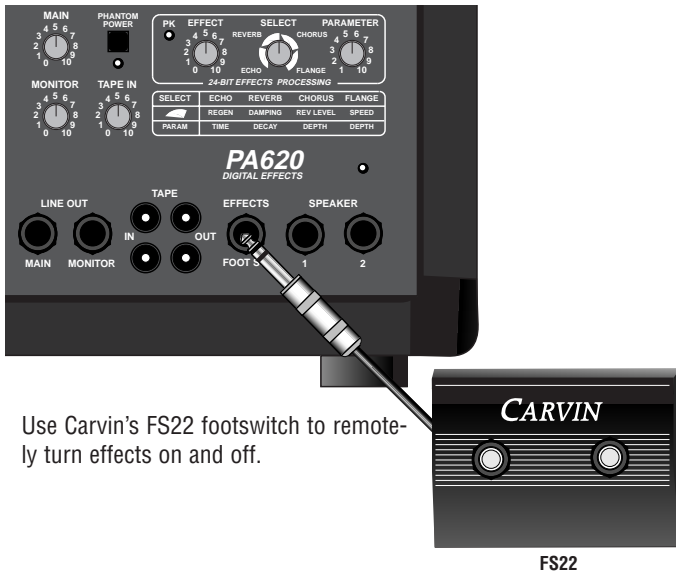

TAPE AND CD IN - OUT

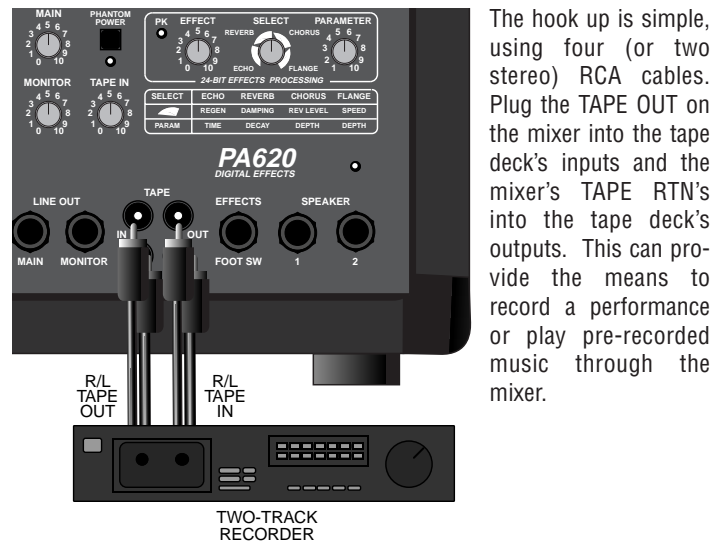

DSP EFFECTS SELECTOR

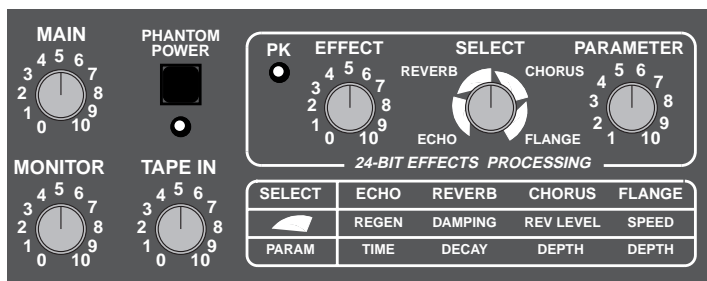

The PA410 and PA620 effects offer a wide array of effect possibilities. Use the SELECT control to dial in your desired effect. Use the PARAMETER control to change characteristics about that effect. For a detailed description of each EFFECT and PARAMETER please see **11. DSP EFFECTS SELECTOR.**

PA410 / PA620 CONTROLS

QUICK START UP

If you're like most new owners, you're probably in a hurry to plug your mixer in and use it. Here are some brief instructions to get you going quickly. With the mixer unplugged and the unit turned off, complete the following procedures:

1. CONNECTING AC POWER TO YOUR MIXER

- Be sure to use the correct power cable for your country. (120VAC or 240 VAC)
- Use only a grounded (3 prong) power outlet to prevent a shock hazard and reduce hum and noise.

2. CONNECTING SPEAKERS

- Use the 1/4" SPEAKER jacks on the front panel to connect up to two 8Ω speakers. The speaker cables are to be non-shielded with a minimum size of 16 gauge. NOTE: Do not run your speakers through microphone wire, guitar cables, or multi-conductor microphone junction boxes or "snakes" as they are sometimes referred to. This wire is normally shielded and of a very light gauge causing a substantial loss of power.

3. CONNECTING INPUTS TO YOUR MIXER

- For low level balanced devices such as microphones, plug into the balanced **MIC** inputs using a shielded XLR cable.
- For high level unbalanced devices such as instruments & Keyboards plug into the **LINE** input jacks using a shielded 1/4" phone cable. Set the **GAIN** switch so the **LEVEL** control is not overly sensitive.

4. TURNING YOUR MIXER ON

- Turn all channel and master **LEVEL** controls to their off positions
- Adjust all "EQ" tone controls—the channel's **HI** and **LOW** and the 7 Band Graphic EQ's to their center position.
- Turn the mixer on by the rear panel **POWER SWITCH** and watch for the **POWER LED** to light. Your mixer is now ready to operate.

MIC CHANNEL FEATURES

1. XLR MICROPHONE INPUT

The **XLR MIC** input is designed for balanced low impedance (microphone) input signals. The differential balanced input amplifier reduces the common noise picked up on the microphone cables. The XLR connector is wired as per the industry standard, pin 1 is ground, pin 2 is non-inverting (positive), and pin 3 is inverting (negative). Phantom power is available on every XLR input jack when the phantom power switch in the master section is pressed. This feature allows condenser microphones to be run directly from the mixer. Note: When using phantom power, make sure the phantom power is switched off before connecting or disconnecting microphones to the mixer. It is recommended to allow 5 seconds for the phantom power to discharge before making any microphone connections. Also, to avoid hearing a pop, turn down the master volume when turning on the phantom power.

2. LINE INPUT JACK

The **LINE** input is a 1/4" phone jack designed for unbalanced line and instrument level inputs. Examples to use in these inputs are guitars, keyboards, mics, or a CD or tape player. The line inputs can be used at the same time the XLR inputs.

3. +20DB GAIN SWITCH

The **GAIN** switch increases the input sensitivity on both the **LINE** and **MIC** input jacks by 20dB. After determining the input is too low for mixing with the level control, turn down the level control, press in the gain switch and adjust the level again. If distortion is heard regardless of the channel **LEVEL** control's setting, disengage this switch to eliminate over-driving of the input stage.

4. CHANNEL LEVEL CONTROL

The **LEVEL** control adjusts the volume of the channel before going to the **MAIN** master **LEVEL**. Here is where the individual channel volumes are adjusted to make up the desired mix heard at the main outputs. A general rule to prevent interstage distortion is to always keep the **MAIN** master **LEVEL** the same or higher than the channel **LEVEL**.

5. MONITOR LEVEL CONTROL

The **MONITOR** level control adjusts the volume of the channel going to the monitor mix. The monitor level control is pre-channel level and pre-channel tone controls. This means it is unaffected by adjustments in channel level and tone controls. The purpose for this is so the main mix adjustments for tone and level can be made without disturbing the monitor mix.

MASTER SECTION FEATURES

8. THE GRAPHIC EQUALIZER

The 7 band graphic EQ is an excellent tool to fine tune the overall mix. Set all sliders to their center detent position. When the sliders are in this position, they do not effect the audio signal. When a slider is raised or lowered it boosts and cuts the listed frequency respectively. One setting that can be used to enhance your sound is to cut the mid range (set the 1KHz slider to -8) and raise the high and low frequencies as shown. This is a common "smile" curve that gives a tight

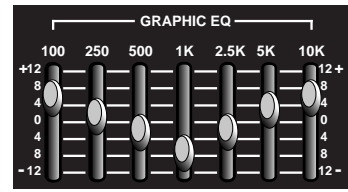

punchy sound with plenty of highs to cut through a crowd. The Graphic EQ can also help to reduce feedback.

PA620



6. CHANNEL EFFECTS LEVEL CONTROL

The **EFFECT** control adjusts the volume of the channel going to the internal effects. Make sure the effects level is not set too high, if the master effect PK (Peak) LED flashes red, turn down the Channel Effect until it stops flashing. See # 11 for more details.

7. CHANNEL TONE CONTROLS

Each channel features active tone controls **LOW** and **HI**. Both function as boost (clockwise) & cut (counter-clockwise) controls where the center 0 position is neutral. Both **LOW** and **HI** are shelving type tone controls with corner frequencies at 80Hz and 11.5k Hz respectively. It is suggested the channel tone controls start out in their center 0 positions. A good setting for added dynamics is to set the **LOW** & **HI** at +6.

9. MAIN MASTER LEVEL CONTROL

The **MAIN** control is the master volume control for the mixer. The **MAIN** will control the volume of the **LINE OUT** jack, the **TAPE OUT** RCA jack and the internal power amplifier (speaker volume).

10. PHANTOM POWER SWITCH AND LED

The **PHANTOM** power switch turns on the microphone phantom power in the channel XLR jacks. This power is used for supplying a bias voltage to condenser microphones. The LED indicates the phantom power is turned on. The phantom power will not damage dynamic microphones.

11. DSP EFFECTS SELECTOR

The 24bit processor will provide a host of awesome sound-effects that include: Flange, Reverb, Echo, & Chorus. The **EFFECT** control will adjust the volume level of the selected effect. Remember each channel has its own **EFFECT** send that will adjust the amount of signal sent to the effects processor. The red **PK LED** will indicate when the effects signal from the channel is clipping. Lowering the channel **EFFECT** control until the **PK LED** stops flashing is a good rule of thumb when setting up your effects. (Note: An audible note can be heard when adjusting the effects).

EFFECT PARAMETERS

Each of the four effects has a variable parameter that can be easily adjusted.

ECHO: When the **SELECT** control is at the "7 O'clock" position, it is selected to the first **ECHO** setting where you get a single repeat echo (minimal regeneration). Turning the **PARAMETER** control to 1 will provide the shortest delay time between the original signal and the echo. Increasing the

Increasing the **PARAMETER** to the right will increase the reverb decay time.

CHORUS: When the **SELECT** control is at the "1 O'clock" position it is selected to the first **CHORUS** setting. Turning the **SELECT** control clockwise will increase the amount reverb in the chorus. Turning the **PARAMETER** control to 1 will provide a minimal chorus depth setting. Increasing the **PARAMETER** to the right will increase the chorus depth.

FLANGE: When the **SELECT** control is at the "4 O'clock" position it is selected to the first **FLANGE** setting. Turning the **SELECT** control clockwise will increase the flanger's speed. Turning the **PARAMETER** control to 1 will provide minimal flanging depth. Increasing the **PARAMETER** to the right will increase the flanger's depth.

12. MONITOR MASTER LEVEL CONTROL

The **MONITOR** master level control is the master volume for the monitor mix which is sent to the monitor output. This control receives its signals from the channel monitor level controls.

15. MAIN OUTPUT JACK

The **MAIN** line out jack is a line level post graphic EQ output of the main mix. Use this to drive an external power amp. This same signal is also being fed to the internal power amplifier.

16. TAPE IN-OUT RCA JACKS

The **RCA IN** jacks are ideal for plugging in keyboard, cassette deck or CD player. The **LEFT/RIGHT TAPE OUT** RCA jacks deliver the main mix for recording (pre graphic EQ).

17. EFFECTS/FOOTSWITCH

Plug the optional **FS22** footswitch into this jack to remotely turn the effects ON or OFF.

18. SPEAKER OUTPUT JACKS

Connect the main speakers to these two 1/4" phone jacks. A total of two 8Ω speakers can be connected (one per jack). Connecting 4Ω speakers or more than two 8Ω speakers will cause the mixer to go into "protect mode" and mute the audio. The output relay will engage after 20 minutes of heavy use when using 4Ω speakers.

19. POWER LED

The **Power LED** indicates when the mixer is powered up.

HELPFUL HINTS

1) FEEDBACK: To reduce feedback, the placement of the speakers with respect to the microphones may need to be reconsidered. As much as possible, try to have the main speaker facing away from and in front of the microphones not on stage behind them. The graphic EQ may be used to reduce feedback from microphones.

2) NO HIGH FREQUENCIES: Check the channel tone controls and EQ settings. The tweeters or midrange drivers may have been damaged or blown from feedback or overpowering.



PARAMETER control to the right will increase the time delay between the original signal and the echo. You can get a maximum of .5 second delay. To increase the number of echoes, turn the **SELECT** control clockwise to "9 O'clock" (maximum regeneration).

REVERB: When the **SELECT** control is at the "10 O'clock" position, it is selected to the first **REVERB** setting. Turning the **SELECT** control clockwise will increase the amount of high frequencies in the reverb. Turning the **PARAMETER** control to 1 will provide minimal decay time of the reverb.



13. TAPE IN

The **TAPE IN** control sets the level coming from the **RCA TAPE IN** jacks. Just like the channel **LEVEL** control, the **TAPE IN** will add this signal to your overall mix with your **MAIN** control adjusting the entire mixer volume output.

14. MONITOR OUTPUT JACK

The **MONITOR** line out jack is the monitor mix from the **MONITOR** master level control. This is a line level output to drive an external power amplifier like our HT100M for separate floor monitors. This output will include any effects mixed at the individual channels allowing you to hear your effects in your monitors!

SYSTEM WITH MONITORS

