 This symbol is intended to alert the user to the presence of uninsulated "dangerous voltage" within the product's enclosure that may be of sufficient magnitude to constitute a risk of electric shock to persons.

**CAUTION**  
RISK OF ELECTRIC SHOCK  
DO NOT OPEN  

This symbol is intended to alert the user to the presence of important operating and maintenance (servicing) instructions in the literature accompanying the appliance.  

**IMPORTANT! FOR YOUR PROTECTION, PLEASE READ THE FOLLOWING:**

**WATER AND MOISTURE:** Appliance should not be used near water (near a bathtub, washbowl, kitchen sink, laundry tub, in a wet basement, or near a swimming pool, etc). Care should be taken so that objects do not fall and liquids are not spilled into the enclosure through openings.

**POWER SOURCES:** The product should be connected to a power supply only of the type described in the operating instructions or as marked on the appliance.

**GROUNDING OR POLARIZATION:** Precautions should be taken so that the grounding or polarization is not defeated.

**POWER CORD PROTECTION:** Power supply cords should be routed so that they are not likely to be walked on or pinched by items placed upon or against them, paying particular attention to cords at plugs, convenience receptacles, and the point where they exit from the appliance.

**SERVICING:** The user should not attempt to service the appliance beyond that described in the operating instructions. All other servicing should be referred to qualified service personnel.

**FUSING:** If your unit is equipped with a fuse receptacle, replace only with the same type fuse. Refer to replacement text on the unit for correct fuse type.

**SAFETY INSTRUCTIONS (EUROPEAN)**

The conductors in the AC power cord are colored in accordance with the following code.  
**GREEN & YELLOW—Earth BLUE—Neutral BROWN—Live**  
U.K. MAIN PLUG WARNING: A molded main plug that has been cut off from the cord is unsafe. NEVER UNDER ANY CIRCUMSTANCES SHOULD YOU INSERT A DAMAGED OR CUT MAIN PLUG INTO A POWER SOCKET.

**LIMITED WARRANTY**

Your Carvin amplifier is guaranteed against failure for 3 YEARS unless otherwise stated. Carvin will service and supply all parts at no charge to the customer providing the unit is under warranty. Shipping costs are the responsibility of the customer. CARVIN DOES NOT PAY FOR PARTS OR SERVICING OTHER THAN OUR OWN. A COPY OF THE ORIGINAL INVOICE IS REQUIRED TO VERIFY YOUR WARRANTY. Carvin assumes no responsibility for horn drivers or speakers damaged by this unit. This warranty does not cover, and no liability is assumed, for damage due to: natural disasters, accidents, abuse, loss of parts, lack of reasonable care, incorrect use, or failure to follow instructions. This warranty is in lieu of all other warranties, expressed or implied. No representative or person is authorized to represent or assume for Carvin any liability in connection with the sale or servicing of Carvin products. CARVIN SHALL NOT BE LIABLE FOR INCIDENTAL OR CONSEQUENTIAL DAMAGES.

When RETURNING merchandise to the factory, you may call for a return authorization number. Describe in writing each problem. If your unit is out of warranty, you will be charged the current FLAT RATE for parts and labor to bring your unit up to factory specifications.  
register online at [www.carvin.com/registration](http://www.carvin.com/registration).

**MAINTAINING YOUR EQUIPMENT**

Avoid spilling liquids or allowing any other foreign matter inside the unit. The panel of your unit can be wiped from time to time with a dry or slightly damp cloth in order to remove dust and bring back the new look. As with all pro gear, avoid prolonged use in caustic environments (salt air). When used in such an environment, be sure the amplifier is adequately protected by rack, covers, etc..

**REPLACEMENT PARTS LIST FOR DCM4000 AMP**



**CAUTION**  
RISK OF ELECTRIC SHOCK

**REFER SERVICING TO QUALIFIED SERVICE PERSONNEL! THIS UNIT CONTAINS HIGH VOLTAGE INSIDE!**

03-00220	4	"INSLTR MICA .0030".450"X .65"X"	49-56152	4	560PF SMT 5% CERAMIC 0805	58-56025	1	560.5 SMT .25W 1206 1% R24
03-00503	4	"INSULATOR .36X.36X.20" 85deg"	49-82052	2	"C149,C150,C249,C250"	58-68035	3	6.8K SMT .25W 1206 1% "R14,R104,R204"
03-92521	12	STANDOFF LED .925 x .215 T1	50-10035	2	82PF SMT 5% CERAMIC 0805 "C144,C244"	58-91025	1	910.5 SMT .25W 1206 1% R22
06-10028	24	MS PPH 4-40X .500 ZINC TYPE F	50-10045	1	RES 1.00KOHM .25W 5% CARBON	60-00014	1	TRANS MPSA14 DRLNGTN NPN TO-92 Q2
06-40050	3	TERMINAL VERT MALE PC MTG. .250	50-22045	1	"R7,R142"	60-15032	2	TRANS MJE15032 NPN TO-220 "Q112,Q212 (SECONDARY)"
06-40060	5	"QC1,QC2,QC3"	50-22045	1	RES 10.00KOHM .25W 5% CARBON	60-15033	2	TRANS MJE15033 PNP TO-220 "Q113,Q213 (SECONDARY)"
07-01602	1	TERMINAL 90deg MALE PC MTG .250	52-10015-1	1	R140	60-21193-1*	12	TRNS BIPOLAR MJL21193-PREPPED
07-01603	4	"QC4,QC5,QC6,QC7,QC8"	53-22025-1*	4	RES 22.00KOHM .25W 5% CARBON	60-21194-1*	12	TRNS BIPOLAR MJL21194-PREPPED
12-40000	1	"KNOB "6" 6x6x9.7mm GREY CAP"	54-02206	24	RES 10.00 OHM .50W 5% CARBON R6	60-35041	2	"Q120,Q121,Q122,Q123,Q124,Q125,Q220,Q221,Q222,Q223,Q224,Q225"
12-57462	1	"KNOB "6L" 6x6x17.4mm GREY CAP"	54-10015-2	4	RES 220.00 OHM 1.00W 5% CBN .3	60-50200	4	RECTIFIER BRIDGE 35AMP/400V PC
15-00105	2	"HEATSINK 12" LENGTH ALUMINUM"	55-15003-1	2	"R168,R171,R268,R271"	60-50255	2	"SECONDARY BR100,BR200"
21-40000	2	HEATSINK VERT W/TABS TO-220	55-05025	4	RES .22 OHM 3.00W 5% BOX	60-54000-1*	2	DIODE GEN RECT 1N5402 3A 200V
21-40001	2	COIL AIR 1.5uH 14AWG "L100,L200"	56-35010	1	"R172,R173,R174,R175,R176,R177,R178,R179,R180,181,R182,R183,R272,R273,R274,R275,R276,R277,R278,R279,R280,R281,R282,R283"	60-54000-2*	2	"D130,D131,D230,D231"
21-45000	3	XLR FEML CON NEUTRIK #NC3FAV-0 "J100,J200"	58-10025	6	RES 10.00 OHM 2.00W 5% CARBON	60-75320	6	OPTO ISOLATOR VACTROL AXIAL "OP100,OP200"
23-03529	2	XLR MALE CONNECTOR "J101,J201"	58-10035	6	RES 1.5K 5W WIRE LEAD RESISTOR "R3,R4"	60-75330	4	TRANS 2N5400 AMP PNP TO-92 "Q101,Q102"
23-08604	3	SPEAKON 4-POLE PCMTG #N4L4MD-V "J1,J102,J202"	58-10045	35	RES 5.00 OHM 5W 5% SB VERT	60-75340	3	TRANS 2N5550 HV NPN 250V TO-92
23-08605	2	FUSEHOLDER CLIPS 3AG VERT MTG F1	58-15055	3	"R143,R144,R243,R244"	60-78150-1*	1	"Q111,Q211(SECONDARY, PLACE THROUGH HOLE)"
23-10002	3	"CONNECT HEADER .086" 4 PIN" "H2,H7A,H7B (SECONDARY)"	58-18035	1	RES 350.00 OHM 10W 10% SB SDOF R5	60-79150-1*	2	LED RED DIFFUSED 3MM T-1.00
23-11002	3	"CONNECT HEADER .100" 2 PIN" "H4,H9,H10"	58-22035	10	100.5 SMT .25W 1206 1%	61-04733	1	"D3,D5,D111,D113,D211,D213"
23-11004	4	CONNECT HEADER 2 PIN STRAIGHT	58-22045	7	"R112,R126,R163,R212,R226,R263"	61-40030	9	LED GREEN DIFFUSED 3MM T-1.00
23-11010	6	"H5,H8A,H8B"	58-22055	7	1K SMT .25W 1206 1%	62-00014	2	"D10,D11,D212,D210,D212"
25-02201	4	CONNECT HEADER 4 PIN STRAIGHT	58-27025	6	"R11,R115,R157,R215,R257,R30"	62-19140	16	LED YELLOW DIFFUSED 3MM T-1.00
25-04201	1	"H2A,H2B,H5A,H5B"	58-30035	2	10K SMT .25W 1206 1%	62-29010	1	REG VOLT 15V-1A (PREPPED) VR1
30-04008B	1	CONNECT HEADER 10 PIN STRAIGHT	58-33035	2	"R12,R13,R17,R28,R31,R100,R101,R102,R103,R120,R121,R127,R128,R150,R152,R153,R167,R185,R187,R200,R201,R202R,203,R220,R221,R227,R228,R250, R251,R252,R253,R267,R285,R287"	62-45650	2	REG VOLT 15V-1A (PREPPED) "VR2, VR3 (WITH HEATSINK)"
41-47322-1	3	SWITCH DPDT PUSH PC MTG LOCKNG	58-36055	4	"R18,R129,R159,R188,R190,R229,R259,R288,R29"	62-54001	3	DIODE ZENER 1N4733A 5.1V 1W Z100
42-10312	4	"S1,S2,S4,S5"	58-36055	4	100K SMT .25W 1206 1%	62-55500	7	DIODE RECT GEN 1N4003 200V 1A
44-13520	4	SWITCH 4PDT PUSH PC MTG LOCKNG S3	58-47025	1	"R11,R115,R157,R215,R257,R30"	70-05713	2	"D10,D11,D12,D13,D14,D15,D16,D17,D120"
46-10412-1	2	PCB CARD MAIN DCM4000	58-47035	6	"R12,R13,R17,R28,R31,R100,R101,R102,R103,R120,R121,R127,R128,R150,R152,R153,R167,R185,R187,R200,R201,R202R,203,R220,R221,R227,R228,R250, R251,R252,R253,R267,R285,R287"	70-05715	1	N1914 HI SPD SMT 250mW DIODE
46-47312-1*	3	CAP POLY .0470UF 100V 10% PREP	58-47045	11	100K SMT .25W 1206 1%	71-09253	2	MMBT414 SOT-23 SMT "Q100,Q200"
47-10235-1	4	CAP MYLR .0470UF 250VAC BOX "C1,C2,C3"	58-47055	3	15K SMT .25W 1206 1%	71-24450	2	NJM2901SMT SINGLE SUPPLY A111
47-47125-1*	1	"CAP ELEC 10.000 MFD 100V 20%" "C12,C13,C14,C15"	58-47055	3	"R25,R122,R123,R184,R186,R222,R223,R284,R28"	71-24450	2	NJM4565 SMT DUAL HI FREQ "A10,A11"
47-47151-1*	1	"CAP ELEC 10.000 MFD 100V 20%" "C12,C13,C14,C15"	58-47055	3	150K SMT .25W 1206 1% "R9,R27,R209"			MMBT5401LTI PNP SOT-23 SMT "Q126,Q226,Q3"
49-10212	2	"JUMPER PCB 20AWG .350" X .175"X"	58-47055	3	2.2K SMT .25W 1206 1%			MMBT5550 NPN SOT-23
49-10451	4	"B1,B2,B3,B4"	58-47055	3	"R2,R32,R110,R111,R132,R193,R210,R211,R232,R293"			"Q1,Q10,Q110,Q127,Q210,Q227,Q5"
49-10451	4	"CAP POLY .1000UF 100V 10%" "C130,C230"	58-47055	3	"R107,R109,R154,R158,R207,R254,R258"			RELAY SPDT 12A@120VAC/24V COIL "K100,K200"
49-22035	15	CAP POLY .0470UF 100V 10% PREP	58-47055	3	220K SMT .25W 1206 1%			RELAY SPDT 15A@120VAC/24V COIL K1
49-22035	15	"C6,C7,C8"	58-47055	3	270.5 SMT .25W 1206 1%			FUSE X2: 25Amp 250V Slow Blow MBA
49-22035	15	"C9,C10,C11,C12,C13,C14,C15"	58-47055	3	"R106,R162,R165,R206,R262,R265"			POT 9 "D-P" 25F B50K-" "P100,P200"
49-22035	15	"C16,C17,C18,C19,C20,C21,C22,C23,C24,C25,C26,C27,C28,C29,C30"	58-47055	3	3.3K SMT .25W 1206 1% "R161,R261"			POT VERT TRIMMER 500ohm "P110,P210"
49-22035	15	"C31,C32,C33,C34,C35,C36,C37,C38,C39,C40,C41,C42,C43,C44,C45,C46,C47,C48,C49,C50"	58-47055	3	33K SMT .25W 1206 1% R21			
49-22035	15	"C51,C52,C53,C54,C55,C56,C57,C58,C59,C60,C61,C62,C63,C64,C65,C66,C67,C68,C69,C70"	58-47055	3	365K SMT .25W 1206 1%			
49-22035	15	"C71,C72,C73,C74,C75,C76,C77,C78,C79,C80,C81,C82,C83,C84,C85,C86,C87,C88,C89,C90"	58-47055	3	"R105,R113,R205,R213"			
49-22035	15	"C91,C92,C93,C94,C95,C96,C97,C98,C99,C100,C101,C102,C103,C104,C105,C106,C107,C108,C109,C110"	58-47055	3	470.5 SMT .25W 1206 1% R16			
49-22035	15	"C111,C112,C113,C114,C115,C116,C117,C118,C119,C120,C121,C122,C123,C124,C125,C126,C127,C128,C129,C130"	58-47055	3	4.7K SMT .25W 1206 1%			
49-22035	15	"C131,C132,C133,C134,C135,C136,C137,C138,C139,C140,C141,C142,C143,C144,C145,C146,C147,C148,C149,C150"	58-47055	3	"R1,R19,R20,R29,R166,R266"			
49-22035	15	"C151,C152,C153,C154,C155,C156,C157,C158,C159,C160,C161,C162,C163,C164,C165,C166,C167,C168,C169,C170"	58-47055	3	47K SMT .25W 1206 1%			
49-22035	15	"C171,C172,C173,C174,C175,C176,C177,C178,C179,C180,C181,C182,C183,C184,C185,C186,C187,C188,C189,C190"	58-47055	3	"R10,R108,R124,R125,R155,R160,R208,R224,R225,R255,R260"			
49-22035	15	"C191,C192,C193,C194,C195,C196,C197,C198,C199,C200,C201,C202,C203,C204,C205,C206,C207,C208,C209,C210"	58-47055	3	470K SMT .25W 1206 1% "R23,R26,R130"			



**DCM4000**

The **DCM4000** was designed for pro sound companies and individuals who require huge amounts of clean RMS power to drive large, professional speaker systems and arrays, as well as high powered monitor systems. This was the main idea and motivation behind the concept of the **DCM4000**: Twice the power - same number of rack spaces. Another advantage of the **DCM4000** was even more obvious - 1400 Watts x 2 at 8 ohms in bridge mode!

**A TON OF POWER X 4**

Each **DCM4000** incorporates four separate 1000 Watt RMS amps and is powered by redundant toroid power supplies that are totally independent of each other. It's like having two complete 2000 watt amps in one 3 space package. The only thing they share is the AC cord so if one of the two primary fuses fails, the other amps are not affected. These four amps can be used to power four separate speakers from four different sources (this is ideal for monitor systems). Each side can be bridged to become two 2000 Watt amps (great for high powered speakers and subwoofers like the Carvin TCS series). Each side can even be paralleled and then chained together to be fed by a single input source (perfect for arrays with a large number speakers).

**AWESOME SOUND!**

What good is a ton of power if it doesn't sound great? The Carvin **DCM4000** is an incredibly transparent amp sporting slew rates well over 50 VmS. With massive dual power supplies and huge reserve capacitors for on-demand power, the **DCM4000** delivers pure, uncolored sound at full output; with tight, punchy lows and open, transparent highs – without a hint of distortion.

**RUGGED TO THE EXTREME**

These pro amplifiers are completely protected from any kind of abuse that might pop up in a typical road rig – thermal, over-current, short-circuit, voltage spikes, “hot-swapping” speakers – the **DCM4000** is designed to protect itself and be right back up and running as soon as the problem is remedied. The all-steel, front & rear rack-able chassis can take whatever abuse is thrown at it. These amplifiers are just what the real pro wants - “rack'em and forget'em”. The **DCM4000** requires a 30A industrial NEMA Twist-Lok AC socket and is “concert-ready” with a thick 10 GA, industrial AC cable capable of pulling in the kind of current necessary to produce 4000 Watts.

**COOLEST COOLING**

Carvin's exclusive “Wind-Tunnel” heat-sink with dual “push/pull” 105 CFM fans, ensures full, uninterrupted RMS power delivery without over-heating concerns. These are continuous-duty amps meaning that if you drive them at full power, 24 hours a day, they won't shut down. And, be assured that you'll get your full power in RMS watts, not pulse or peak power.

**DISTORTION-FREE LIMITERS**

The purpose of a limiter is to hold down peaks so the amp won't distort even with extra hot input signals (this protects your expensive speakers). In addition, a well designed limiter can increase your amp's average output as much as 3 db. Part of Carvin's design uses the more expensive, distortion-free linear “opto isolators”. Unlike amps that use FET controlled limiters which can inject small amounts of distortion, the DCM Series limiters keep your sound pure and uncolored!

**FRONT & REAR PANELS**

Along with the normal Gain controls and Signal, Clip, and Power indicators, we've included a very useful “Bridge Mode” indicator to avoid inconvenient or even costly hook-up mistakes. On the back panel you get a male and female XLR input per amp (perfect for daisy-chaining amps). The **DCM4000** features a speaker output section with professional high current Twist-Lok and Banana/Binding Post connectors to mate with any pro speaker rig. Each dual-amp side features switches for Bridging, Parallel input, Ground Lift, Limiter, and Sub-sonic filter.

**RECEIVING INSPECTION**

INSPECT YOUR SPEAKER FOR ANY DAMAGE which may have occurred during shipping. If any damage is found, please notify the shipping company & CARVIN.

SAVE THE CARTON & ALL PACKING MATERIALS. In the event you have to re-ship your unit, always use the original carton and packing material. This will provide the best possible protection during shipment. CARVIN and the shipping company are not liable for any damage caused by improper packing.

SAVE YOUR INVOICE. It will be required for warranty service if needed in the future.

SHIPMENT SHORTAGE. If you find items missing, they may have been shipped separately. Please allow several days for the rest of your order to arrive before inquiring.

RECORD THE SERIAL NUMBER on the enclosed warranty card or below on this manual for your records. Keep your portion of the card and return the portion with your name and comments to us. Or you may register online at [www.carvin.com/registration](http://www.carvin.com/registration)

**DCM POWER AMP SPECIFICATIONS:**

<b>MODEL DCM4000</b>	
<b>Bridged RMS Continuous</b>	
4Ω, (1k Hz, <1.0%)	2000w x 2
8Ω, (1k Hz, <1.0%)	1400w x 2
<b>All Channels RMS Continuous</b>	
2Ω (1k Hz, <1.0%)	1000w x 4
4Ω (1k Hz, <1.0%)	700w x 4
8Ω (1k Hz, <1.0%)	425w x 4
<b>THD (Typical—1/2 power):</b>	0.03%
<b>Damping Factor:</b>	>500
<b>Slew Rate:</b> bridged mode	50v/μs
<b>Sensitivity:</b>	(4Ω, Vms) 1.0 V
<b>Signal to Noise Ratio:</b>	Above 100dB
<b>Frequency Response:</b>	±0.5 dB, 20 Hz to 20kHz (±1.5 dB, 10 Hz & 40 kHz)
<b>Input Impedance:</b>	20K Ω, balanced

**Protection Circuits:** • Short Circuit • No Load Protection • SpeakerGuard™  
• Thermal Shut-Off • Mute On/Off

**Controls and Indicators**

**Front:** • Power switch • Recessed detent attenuators • Signal LED • Clip LED • Protect LED • Power ON Indicator

**Rear:** Ground Lift (each channel) • Parallel Input Switch • Speaker Output Bridge Switch • Limiters IN/OUT Switch • Input Connectors: Two each; Balanced XLR & 1/4" • Speaker Output Connectors: Dual heavy-duty binding posts, six Twist-Lok (two bridged).

**Dimensions:** 5 1/4" High x 19" Wide x 16" Depth (3-space)

**Net Weight:** 70 lbs.

**Power :** 120 VAC 30 amp circuit minimum. (50 amp recommended)

240 VAC 15 amp circuit minimum. (25 amp recommended).

(Note: You may use an adapter to convert the special 30 amp plug to a standard 120V plug using a dedicated 20 amp circuit when using reduced loads. You may use 8Ω loads at moderate levels. However, 2Ω, 4Ω or bridged loads at higher levels will cause a 20 amp circuit breaker to trip.)

For your records, you may wish to record the following information.

Serial No. \_\_\_\_\_ Invoice Date \_\_\_\_\_



12340 World Trade Drive, San Diego, CA 92128  
800.854.2235 [www.carvin.com](http://www.carvin.com)

## FRONT & REAR PANEL CONTROLS

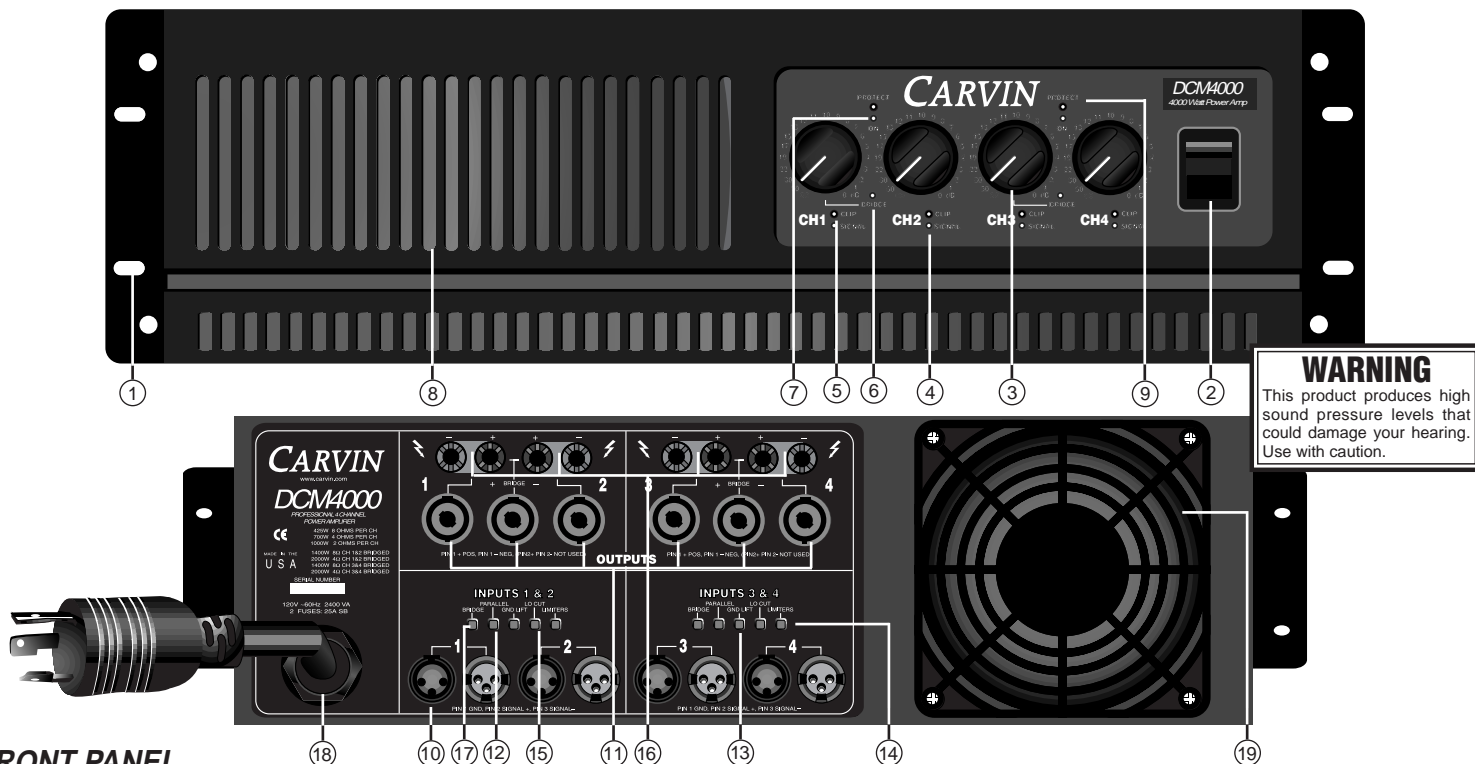

### FRONT PANEL

**1. MOUNTING** A sturdy one piece 12 gauge steel face plate accommodates easy transporting along with facilitating rack installation. The rack mounting holes are designed on ISO standard spacing. Four 10-32 x .5" phillip machine screws are normally used to secure the amp. The rear support brackets must also be used, which are adjustable from a depth of 13" to 19".

**2. POWER SWITCH** Check the power amp connections and verify the AC line power source before engaging the POWER switch. The yellow LED unmistakably indicates that all circuits are properly powered up. Yellow is used so the operator can see the red indicators (clipping or protect) from a distance.

**3. CHANNEL LEVEL CONTROL** Precision input LEVEL attenuators are used to adjust the volume levels. To deliver the amp's maximum power without reducing the headroom of the signal source, the level controls should be turned full on.

**4. CHANNEL SIGNAL INDICATOR** The green SIGNAL LED indicators will start to flash when there is a signal passing to your speakers (-30dBm).

**5. CHANNEL CLIP INDICATOR** The red CLIP LED indicators will start to flash when each channel has reached its maximum output. Occasional flashing caused by lower bass frequencies is OK. However, consistent flashing caused from higher frequencies may damage high frequency drivers (excessive distortion). This does not cause damage to the amp.

**6. BRIDGE MODE INDICATOR** This yellow LED will indicate when the rear "bridged" switch has been engaged and you're running a pair of channels in the "bridge" mode.

**7. POWER INDICATOR/FUSES** This Yellow LED will indicate power to each pair of amps. If one pair does not come on, remove the top lid and replace both 25 AMP 250 Volt slow blow MBA fuses located in the center bottom of the amp.

**8. FRONT COOLING VENTS/FAN** Upon rack installation, the rear of the amp must be fully exposed to room temperature air. The surrounding air should not be warmer than 120° or the thermal protection will engage. The front cooling vents are not to be restricted from exhausting the warm air.

**9. PROTECT LED INDICATOR** The red PROTECT LED provides the operator with information about the status of the amplifier. The PROTECT LED can come on under 3 different conditions (when this happens both channels are muted)

- 1) During power-up, the amplifier stays in a muted state for approx. 3 sec until it determines that everything is functioning normally (no output shorts or over temp conditions).
- 2) When the output load draws excessive current or a direct short is detected in a speaker cable or speaker system, reset this condition by turning the amp off for two seconds and then on again. Check for shorted cables and proper impedance (2 ohms minimum per ch or 4 ohms BRIDGED).
- 3) Overheating is usually determined when the amp stops in the middle of a performance and the PROTECT LED comes on. If this is the case, leave the amp on for the fan to cool the amp down. The amp will automatically reset within 1 to 3 minutes. The PROTECT LED will turn off when ready. Check for the following conditions; a) The rear intake air is restricted, b) The intake air is extremely warm, c) The front exhaust vents are restricted, or d) Excessive speaker load (try other speakers or remove speakers if you are lower than the recommended minimum impedance).

### REAR PANEL

**10. XLR CHANNEL INPUTS** Balanced XLR inputs are featured on each channel. Each channel also features an XLR "through" connector for daisy chaining your input signals to other channels or amps. XLR pin configuration. Pin 1: Grounded through the GROUND LIFT switch, Pin 2: positive Bal. signal and Pin 3: negative Bal. signal.

**11. SPEAKER OUTPUT CONNECTORS** Each channel has a high current Twist-Lok speaker connector. A 12 gauge cable is recommended such as Carvin's SP series cables. Channel pairs 1 and 2, 3 and 4 also have a bridged Twist-Lok connector for bridging the four 1000 watt channels into a pair of 2000 watt outputs. (see 17 BRIDGE MODE.)

**12. PARALLEL INPUTS** The rear parallel switch for inputs 1 and 2 allows you to feed a single input signal into input 1 and have it also drive input 2 without a "Y" cable (this also applies to inputs 3 and 4 respectively). Push in the parallel switch and plug your input cable into INPUT 1. Channels 1 and 2 will now have the same input signal. Each side of the amp (1 & 2 or 3 & 4) can be set up independently. You can parallel 3 and 4 while leaving 1 and 2 unparallelled and so on. In order to parallel the entire amp, push in both parallel buttons and plug a short XLR cable from channel 2 into channel 3. This will provide the entire amp with the same input signal.

**13. INPUT GROUND LIFT** Many times sound systems are connected in such a manner to cause a grounded loop with the inputs that result in audible hum. The input GND LIFT switches on the rear panel will help eliminate this problem. If not, another way to eliminate ground loops is to install a "line matching" transformer between the amplifier input and the signal source and then cut the wires to PIN 1 and ground terminals.

**14. LIMITERS** To activate the LIMITERS, engage the rear limiter switches. The built-in high quality limiters are recommended to hold down peaks that could cause early distortion. Limiters will help to raise the average power so that you can get more output. To check the effectiveness of the limiters when the channel starts to distort (under the amp's full output), engage the limiters and hear the reduction of the distortion. If the distortion stops, you can turn the channel up for more power. The lower bass frequencies are most affected. **WARNING:** Do not check in an environment where the sound level could damage your ears!

**15. LO CUT** When this mode is engaged it cuts -6dB per/octave @ 30Hz. This helps to eliminate pops and bumps on vocal mics and stage rumble.

**16. SPEAKER OUTPUT BINDING POSTS** Wire sizes up to 7 gauge (50 amps) can be inserted into the binding post "side holes". Large cables can be used with "banana" plugs which plug into the end of the binding posts (remove colored caps). Binding posts are spaced on ISO standards. Use the two center RED binding posts for BRIDGED speaker connections (see 17 BRIDGE MODE).

**17. BRIDGE MODE—25V/70V DISTRIBUTION SYSTEMS** The "DCM" Series can be operated in bridge mode if you require a 25V/70V distribution speaker system or high powered at high output impedances. With your amp off, push in the rear (recessed) BRIDGE switch after you have made your speaker connections. The INPUT and LEVEL is handled by channel 1 and 3. The minimum speaker impedance is 4 ohms. **CAUTION:** The power developed by bridging your amp can destroy most speaker systems!

**18. AC POWER** The DCM4000 requires a 30 amp industrial NEMA twist-lock AC socket for the dual toroid power supplies. It is designed to run on either 120V 60Hz or 240V 50Hz depending on the model purchased. The rear 10 gauge heavy-duty NEMA power cable must be plugged into a 30 Amp twist lock NEMA socket. Firmly push into the socket and twist clockwise to lock. Never defeat the grounded connection or electrocution may result!

**19. FAN INTAKE** Upon rack installation, the rear of the amp must be fully exposed to room temperature air. The surrounding air should not be warmer than 120° or the thermal protection could activate. The front cooling vents are not to be restricted from exhausting the warm air.



## TYPICAL BRIDGE STEREO SETUP

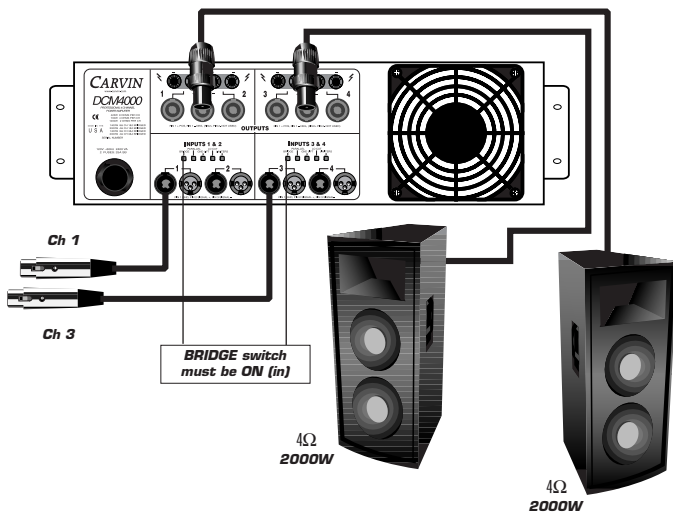

## TYPICAL STEREO BIAMP SETUP WITH 2 DCM4000

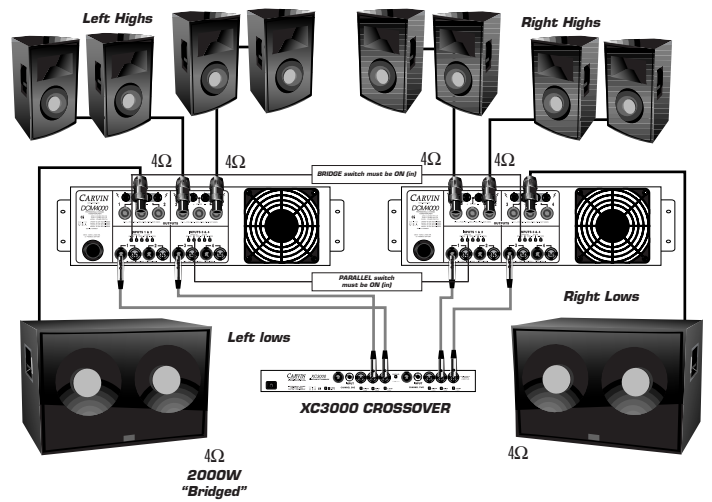

## FULL LOAD SETUP

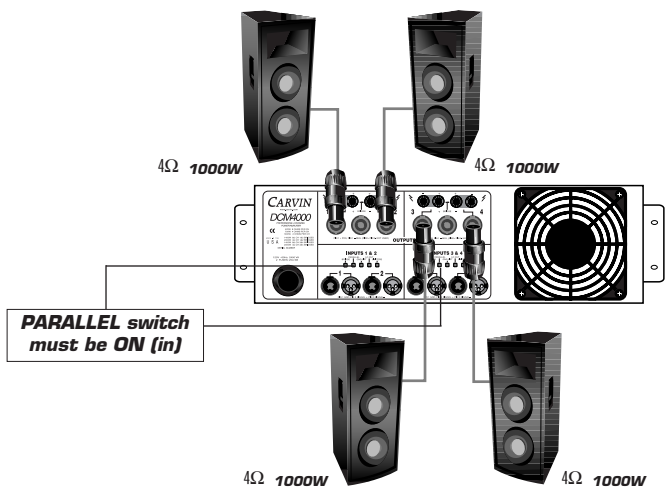

## MULTI AMP PARALLEL INPUT SETUP

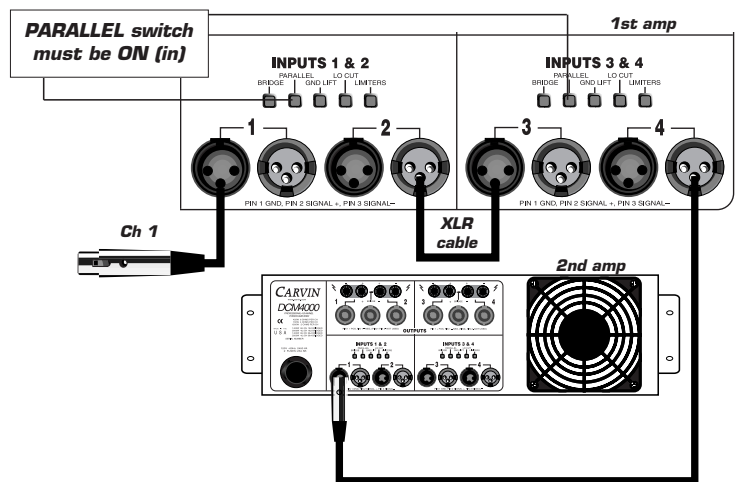

(Shielded)

## BALANCED MIC/LINE XLR CABLES

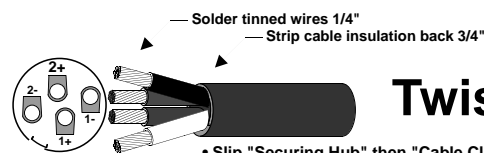
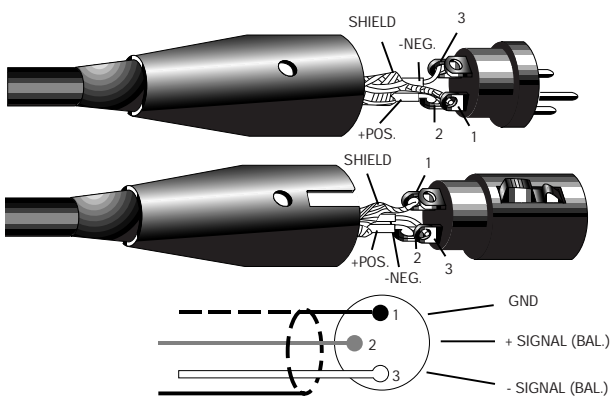

## Twist-Lok

- Slip "Securing Hub" then "Cable Clamp" over cable before attaching wires.
- Connection Configuration:  
Black (1+) / pos. full range mode, Low pos. Bi amp mode  
White (1-) / neg. full range mode, Low neg. Bi amp mode  
Red (2+) / not used  
Green (2-) / not used
- Solder wires in contacts or use hex screws provided.

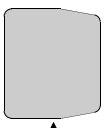
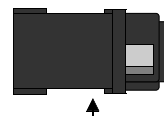
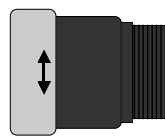

## HELPFUL HINTS

### 1. No sound from Ch 2 or 4:

The rear BRIDGE switch has been inadvertently pushed in.

### 2. Stereo channels sound the same:

The rear PARALLEL switch has been inadvertently pushed in.

### 3. No High Frequencies:

Tweeters or midrange drivers have been damaged or blown from feedback or overpowering.

### 4. System hum:

Try switching the GND LIFT switch IN or OUT (depending on your use).

If the hum is not eliminated, then use a 600Ω line input transformer cutting the input ground on the connectors (Pin 1). This isolates the input ground from the AC power ground.

### 5. Poor sound (poor bass):

The speaker systems are wired out of phase to each other. To correct, reverse the wires on one speaker connector only and your bass response should improve.

### 6. Main AC breaker trips:

Each 120VAC DCM4000 amp will require a separate 50 amp circuit (240V: 25 amp) to deliver its full sine wave power with a bench load.