

CARVIN

973 Direct Radiating Speaker System

The 973 loudspeaker system represents a design breakthrough—true studio quality sound in a high output sound reinforcement speaker. It's a difference you can hear. A truly state-of-the-art loudspeaker, the 973 features computer aligned components for optimal performance and superior sound quality. Whether for use in a club, church, or concert hall, the 973 sets a new standard for sound reinforcement.

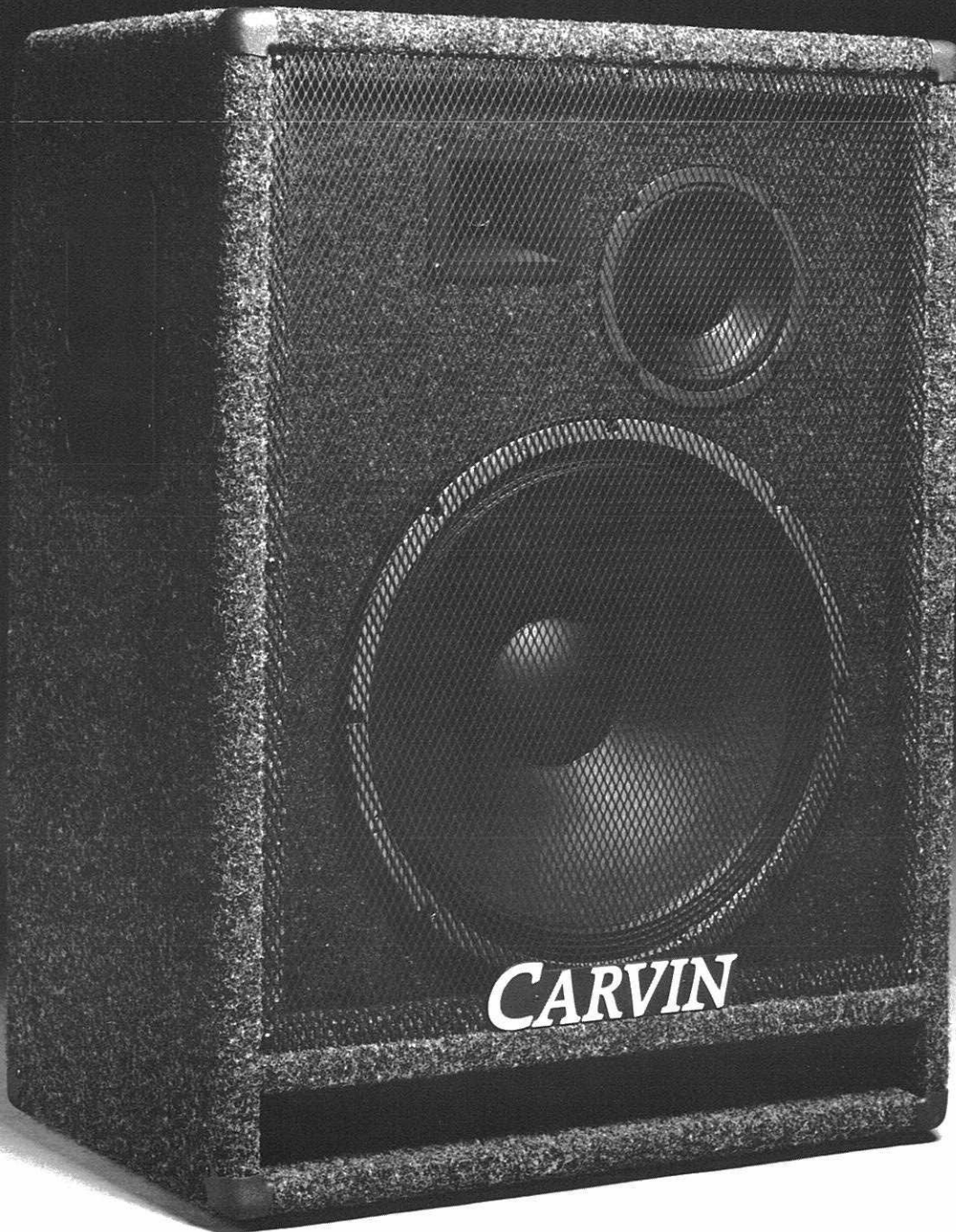

CONGRATULATIONS on your selection of CARVIN products: "The Professional's Choice." Your new speaker system demonstrates CARVIN's commitment to producing the highest quality & most thoroughly engineered products in pro audio.

Please send in the warranty card. It will allow us to better understand how you are using the equipment while keeping a ready reference for our files.

RECEIVING INSPECTION

INSPECT YOUR SPEAKER SYSTEM FOR ANY DAMAGE which may have occurred during shipping. If any damage is found, notify the shipping company and call CARVIN immediately.

SAVE THE CARTON & ALL PACKING MATERIALS. In the event you have to re-ship your speaker, always use the original carton and packing material. This will provide the best possible protection for your speaker during shipment. **CARVIN and the shipping company are not liable for any damage caused by improper packing.**

SAVE YOUR INVOICE. It will be required for warranty servicing of your unit. Always check your invoice against the items you have received.

SYSTEM CONNECT PLATE

For maximum versatility, you have a choice of 1/4" phone or XLR connectors. Use the **NORMAL** connection setup shown in the below diagram. Set the **MODE SWITCH** to **NORMAL** (factory setting). **XLR CONNECTOR WIRING:** Pin 1: GROUND, Pin 2; HOT (red binding post on your amp), Pin 3; Not used.

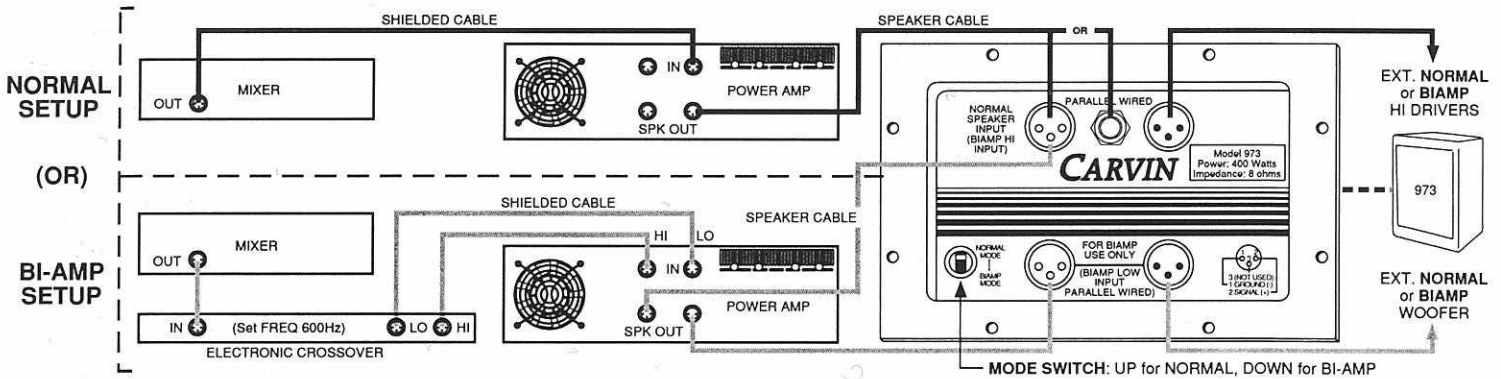

BIAMPING INPUTS

Your speaker system offers two separate inputs to access the Woofer, Mid Range, and Tweeter Drivers for Biamping. By dividing your signal into HI and LO bands by means of an Electronic Crossover (HI to one amp and LO to another amp), you have independent control over your Hi and Lo frequencies. The advantages are obvious. Each power amp handles only a portion of the signal and you have direct control of how much signal is delivered to each driver. **BIAMP MODE SWITCH:** Remove the rubber cap and move the switch **UP** for **BIAMPING** using a small slot screwdriver—See above Diagram.

IMPORTANT: Set the frequency of the electronic crossover for 600Hz. You can experiment by adjusting your frequency range from 500 to 700Hz for your desired sound. **NOTE: The Midrange driver capacity is reduced substantially as the crossover frequency is reduced below 500Hz.**

CAUTION: Excessive power from either amp (LO or HI) will damage the drivers—this is easy to do because you have direct access to the drivers.

SPEAKER CABLES

CARVIN offers its standard 50' **PH50** speaker cable featuring heavy-duty 16 ga copper wire and 1/4" phone plugs for speaker to amp hookups. For amps that feature XLR speaker output connectors, you may select the heavy-duty CARVIN 50' XLR **XP50** speaker cable. For longer runs over 150', 14 ga. wire is recommended. **IMPORTANT: Do Not Use Shielded Guitar or XLR Mic Cables.** Using a shielded cable could cause your amp to "thermal protect" and shut down.

SUGGESTIONS FOR OPTIMAL PERFORMANCE

- 1) Direct the enclosure to the ear level of your audience for optimal coverage.
- 2) Control feedback with a graphic or parametric equalizer—keep the speaker in front of the microphones (**feedback may damage your horn driver**).
- 3) For maximum bass response, place the speaker on the floor, next to a wall (preferable a corner wall).
- 4) For greater coverage, add a second speaker system 20° to 30° off axis.
- 5) **CAUTION:** Using a high powered amplifier in its "Bridged" mode may exceed the power rating of this system and damage all system drivers.

DAISY CHAINING (EXTENSION SPEAKER)

The Rear Connect Plate on all CARVIN speaker systems permit extending ("Daisy Chaining") one additional speaker system to your amp. It is not recommended that you "daisy chain" more than one system. You must also recalculate the total speaker impedance to your amp. If your speaker has a 4Ω impedance and you daisy chain another 4Ω speaker, your total impedance is 2Ω. Most power amps are not designed for less than 4Ω or they will "thermal protect" and shut down. If you are using the 1/4" Phone Jack for the input, you may use the XLR connector for the extension speaker or vice-versa.

DRIVER PRECAUTIONS

- Be advised of the following conditions to protect your speaker system:
- 1) **DO NOT EXCEED THE POWER RATING** marked on the rear connect plate (Carvin systems are conservatively rated allowing occasional peak power above the normal rating. However, excessive power will destroy the drivers).
 - 2) **DISTORTION (square wave) will destroy drivers regardless of power ratings.**
 - 3) **WATER, MOISTURE, and DUST** are harmful to drivers causing failure that is not covered under warranty.

WARRANTY

CARVIN loudspeakers are covered by a ONE year limited warranty. Warranty coverage is limited to original manufacturing defects only. **WARRANTY DOES NOT COVER:** 1) Opened or burned voice coils. 2) Torn cones caused by improper packing or abuse. 3) Damage from rain, moisture, etc.

WARRANTY REPAIRS

To help reduce shipping costs, defective drivers can be removed from the enclosure. Return pre-paid by UPS. Include your address and detailed description of the problem. Your driver will be returned COD for the cost of shipping and reconditioning if the problem is not covered under warranty.

MODEL 973 SPEAKER SYSTEM SPECS:

Frequency Response:	58Hz to 19 kHz ±3 dB
Useable Low Frequency	
Bandwidth:	38 Hz (-10 dB)
Power Handling:	400 watts Continuous Program Power
Recommended Amp:	75 to 600 watts
Sensitivity:	100 dB SPL
Coverage Angles:	90° Horizontal, 45° Vertical
Nominal Impedance:	8Ω
Crossover Frequency:	600 and 3 kHz
Input & Output Connectors:	Two XLR & One 1/4" Phone Connectors
BIAMP Connectors:	Two XLR Connectors
Woofer Enclosure Type:	Computer Optimized Vented Box
Enclosure Covering:	Duratuff™
Dimensions:	22"W x 15.5"D x 30.5" H
Warranty:	One Year, Extended Warranty available
Options:	Cables: PH50 or XP50, Vinyl Cover: CVS973

CARVIN

1155 Industrial Ave., Escondido, CA 92029
toll free: (800)854-2235