

NOTES: UNLESS OTHERWISE SPECIFIED.
 4. ADDED AS SECONDARY OPERATION.
 3. ALL OP AMPS ARE TYPE 4556, EXCEPT AS NOTED.
 2. ALL CAPACITORS IN MICROFARADS, EXCEPT AS NOTED.
 1. ALL RESISTORS IN OHMS

CARVIN 12340 World Trade Drive
 San Diego, CA 92128
 (858) 487-1600
 FAX 487-6629

**BX500, BX550
 System Master**

DRAWN BY: ERIC PETERSEN DATE: 06AUG2008
 APPROVED: DATE:
 PCB NO: 30-45500 REV: K
 ASSY NO: 80-45501 REV: L
 REVISED BY: ERIC PETERSEN DATE: 8FEB2013

CHANGES TO REV(J):
 1. New turn off circuit, and fan start up cap.

CHANGES TO REV(I):
 1. Flyback supply corrections and added feedback limiter and front panel LEDs.

CHANGES TO REV(H) no production:
 1. Flyback supply

CHANGES TO REV(G):
 1. Flyback supply

CHANGES TO REV(F):
 1. ADDED C65
 2. CORRECT DRILL DRAWING FOR PROPER T.H. PLATING

CHANGES TO REV(E):
 1. CHANGE TO DISCRETE NON-REGULATED POWER SUPPLY
 2. FRONT END COMPRESSOR CHANGED FROM OPTO TO LM13700 CIRCUIT
 3. REMOVED OUTPUT RELAY

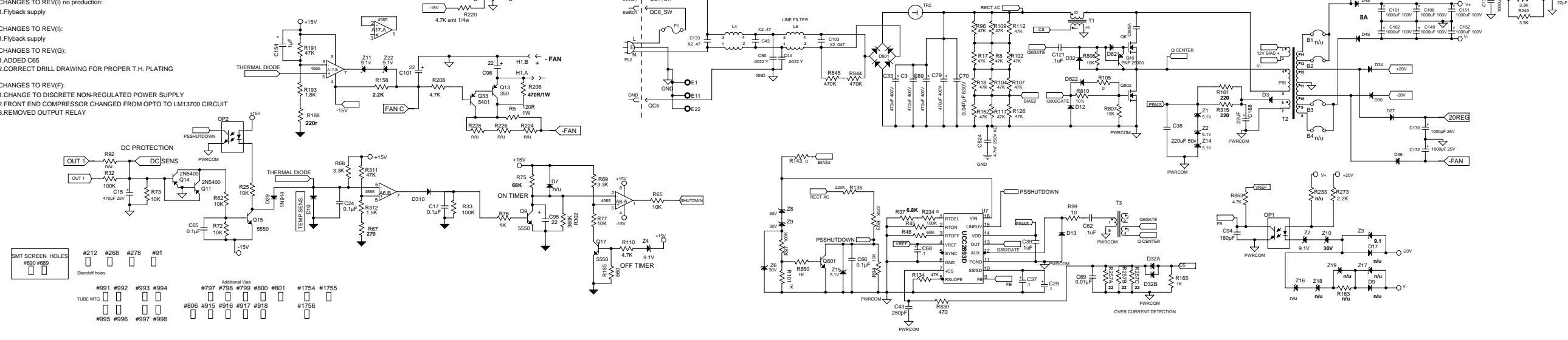

SMT SCREEN HOLES #890 #898

#212	#268	#278	#91
#991	#992	#993	#994
#995	#996	#997	#998

Additional Hole

#797	#798	#799	#800	#801	#1754	#1755
#806	#915	#916	#917	#918	#1756	

TUBE MTO

--	--	--	--	--	--	--

- E21 ● E24
- E25 ● E28
- E23 ● E4