

LIFT CHAIR

SERIES



OWNER'S MANUAL

The symbols below are used throughout this owner's manual and on the product to identify warnings and important information. It is very important for you to read them and understand them completely.



WARNING! Indicates a potentially hazardous condition/situation. Failure to follow designated procedures can cause either personal injury, component damage, or malfunction. On the product, this icon is represented as a black symbol on a yellow triangle with a black border.



MANDATORY! These actions should be performed as specified. Failure to perform mandatory actions can cause personal injury and/or equipment damage. On the product, this icon is represented as a white symbol on a blue dot with a white border.



PROHIBITED! These actions are prohibited. These actions should not be performed at any time or in any circumstances. Performing a prohibited action can cause personal injury and/or equipment damage. On the product, this icon is represented as a black symbol with a red circle and red slash.

Please fill out the following information for quick reference:

Pride Provider: _____

Address: _____

Phone Number: _____

Purchase Date: _____ Serial Number: _____

NOTE: This owner's manual is compiled from the latest specifications and product information available at the time of publication. We reserve the right to make changes as they become necessary. Any changes to our products may cause slight variations between the illustrations and explanations in this manual and the product you have purchased. The latest/current version of this manual is available on our website.

PRODUCT SAFETY SYMBOLS

The symbols below represent labels used on the product to identify warnings, mandatory actions, and prohibited actions. It is very important for you to read and understand these symbols completely. Do not remove these labels from your product. Please note that not all of the symbols may be used on your lift chair model.



Pinch/Crush Points Hazard! Do not place objects or appendages in the path of moving parts.



Electrical Hazard



Read and follow the information in the owner's manual.



Maximum weight capacity

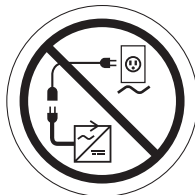

Do not connect an extension lead to the AC/DC converter or the battery charger.



This product has been tested and complies to IEC 60601-1-2.



Properly dispose of all electronic components, including the external transformer, hand control, batteries, actuator motors, and wiring. Contact your authorised Pride Provider for more information.



Do not place objects under lift chair. Make sure area is clear of obstructions, including pets and small children during operation.



Do not place objects under the footrest when lift chair is in fully reclined position. Make sure area is clear of obstructions, including pets and small children during operation.



Do not cover or place the external transformer under the chair. Keep in an open, well-ventilated area free from foreign material and away from possible pinch points.



Battery Door Location



Indoor Use Only. Avoid exposure to rain, snow, ice, salt, or standing water. Maintain and store in a clean and dry environment.

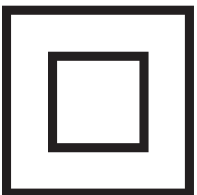

Class II Equipment

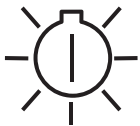

Green LED indicates power to the unit is on. Not applicable to all models.



Degree of protection against electric shock.

SAFETY GUIDELINES 2

LABEL INFORMATION 3

I. INTRODUCTION..... 6
 SAFETY6
 PURCHASER’S AGREEMENT.....6
 INFORMATION EXCHANGE.....6

II. GENERAL GUIDELINES 7
 MODIFICATIONS7
 WEIGHT LIMITATIONS7
 PINCH/CRUSH HAZARDS.....7
 DEGREE OF PROTECTION/MODE OF OPERATION7
 STORAGE AND OPERATION TEMPERATURES7
 EMI/RFI8
 SHIPPING AND DELIVERY8
 MOTOR VEHICLE TRANSPORT8

III. YOUR LIFT CHAIR..... 9
 BODY COMPONENTS9
 ELECTRICAL COMPONENTS10

IV. ASSEMBLY/DISASSEMBLY 12
 LIFT CHAIR SETUP12
 LIFT CHAIR PLACEMENT14
 BATTERY INSTALLATION.....14
 LIFT CHAIR DISASSEMBLY15

V. OPERATION..... 16
 OPERATION PRECAUTIONS.....16
 HAND CONTROL OPERATION16

VI. TROUBLESHOOTING 20
 FREQUENTLY ASKED QUESTIONS.....20

VII. CARE AND MAINTENANCE 22
 FABRIC CARE.....22
 ELECTRONICS CARE22
 DISPOSAL AND RECYCLING22

VIII. WARRANTY 23

APPENDIX..... 24



SAFETY

WELCOME to Pride Mobility Products (Pride). The product you have purchased combines state-of-the-art components with **safety**, comfort, and styling in mind. We are confident the design features will provide you with the conveniences you expect during your daily activities. Understanding how to **safely** operate and care for this product should bring you years of trouble-free operation and service.

Read and follow all instructions, warnings, and notes in this manual and all other accompanying literature before attempting to operate this product for the first time. In addition, your **safety** depends upon you, as well as your provider, carer, or healthcare professional in using good judgement.

If there is any information in this manual which you do not understand, or if you require additional assistance for setup or operation, please contact your authorised Pride Provider. **Failure to follow the instructions, warnings, and notes in this manual and those located on your Pride product can result in personal injury or product damage and will void Pride's product warranty.**

PURCHASER'S AGREEMENT

By accepting delivery of this product, you promise that you will not change, alter, or modify this product or remove or render inoperable or unsafe any guards, shields, or other safety features of this product; fail, refuse, or neglect to install any retrofit kits from time to time provided by Pride to enhance or preserve the safe use of this product.

INFORMATION EXCHANGE

We want to hear your questions, comments, and suggestions about this manual. We would also like to hear about the safety and reliability of your new lift chair, and about the service you received from your authorised Pride Provider. Please notify us of any change of address, so we can keep you apprised of important information about safety, new products, and new options that can increase your ability to use and enjoy your lift chair. Please feel free to contact us at the address below:

Pride Mobility Products Australia Pty. Ltd.
21 Healey Road
Dandenong, 3175
Victoria, Australia

NOTE: If you ever lose or misplace your product registration card or your copy of this manual, contact us and we will be glad to send you a new one immediately.



Your lift chair is a state-of-the-art life-enhancement device designed to increase mobility. Pride provides an extensive variety of products to best fit your individual needs. Please be aware that the final selection and purchasing decision regarding the type of lift chair to be used is the responsibility of you, the lift chair user, if capable of making such a decision, and/or your health-care professional (i.e., medical doctor, physical therapist, etc.).



MANDATORY! Read and follow the information provided in this owner's manual before attempting to operate your lift chair for the first time.

There are certain situations, including some medical conditions, where you will need to practice operating the lift chair in the presence of a trained attendant. A trained attendant can be defined as a family member or healthcare professional specially trained in assisting you with performing various daily living activities while safely operating a lift chair.

Below are some precautions, tips, and other safety considerations that will help you become accustomed to operating the lift chair in a safe manner.

MODIFICATIONS

Pride has designed and engineered your lift chair to provide maximum comfort and utility. However, to prevent personal injury and/or damage to your lift chair, you should not modify, add, remove, or disable any feature, part, or function of your lift chair. Unauthorised modifications may also void your product's warranty.

NOTE: Use Pride parts only for all repairs and replacements.

WEIGHT LIMITATIONS

Your lift chair is rated for a maximum weight capacity. Refer to "Appendix A" for more information.



MANDATORY! Stay within the specified weight capacity of your lift chair. Pride will not be held responsible for injuries and/or product damage resulting from failure to observe weight limitations.

PINCH/CRUSH HAZARDS

The scissor and lift mechanisms are labeled as pinch/crush point hazards on your lift chair. Keep clear of these areas and make sure the path of motion is unobstructed. **See figure 3.1** for pinch/crush point locations.



WARNING! Do not place objects or appendages in the path of moving parts.

DEGREE OF PROTECTION/MODE OF OPERATION

- Class II equipment/Type B protection against electric shock
- Degree of protection against the ingress of solid/liquids—IPX0
- Mode of operation—Maximum Duty Cycle: 2 min. ON/18 min. OFF

STORAGE AND OPERATION TEMPERATURES

- Transportation or storage: -75°C/-104°F to 70°C/158°F
- Operation: 10°C/50°F to 40°C/104°F

ELECTROMAGNETIC AND RADIO FREQUENCY INTERFERENCE (EMI/RFI)



WARNING! Laboratory tests have shown that electromagnetic and radio frequency waves can have an adverse affect on the performance of electrically-powered devices, such as lift chairs.

Electromagnetic and Radio Frequency Interference can come from sources such as cellular phones, mobile two-way radios (such as walkie-talkies), radio stations, TV stations, amateur radio (HAM) transmitters, wireless computer links, microwave signals, paging transmitters, and medium-range mobile transceivers used by emergency vehicles. In some cases, these waves can cause unintended movement or damage to the control system of electrically-powered devices. The lift chair user can help prevent electromagnetic interference by maintaining a minimum distance between portable and mobile RF communications equipment. It is recommended that at least 3 metres (9 feet) of distance be maintained between the lift chair and any handheld equipment emitting 10 W or more of output power. Refer to the manufacturer's literature for the handheld device to determine the maximum output of that device.

Every electrically-powered device has an immunity (or resistance) to EMI. The higher the immunity level, the greater the protection against EMI. Per EMC standards, this product has passed immunity testing and is rated as a Group 1, Class B product, meaning the lift chair uses RF energy only for its internal function. Therefore, its RF emissions are very low and are not likely to cause any interference in nearby electronic equipment, making the lift chair suitable for use in all establishments, including domestic establishments and hospitals.



WARNING! Be aware that cell phones, two-way radios, laptops, and other types of radio transmitters may cause unintended movement of your electrically-powered device due to EMI. Exercise caution when using any of these items while operating your lift chair.



WARNING! The addition of accessories or components to the lift chair can increase the susceptibility of the chair to EMI. Do not modify your lift chair in any way not authorised by Pride.

WARNING! Your lift chair itself can disturb the performance of other electrical devices located nearby, such as alarm systems.

NOTE: If unintended motion occurs, discontinue use of the lift chair. Contact Pride to report the incident.

SHIPPING AND DELIVERY

Before using your lift chair, make sure your delivery is complete as some components may be individually packaged. If you do not receive a complete delivery, please contact your authorised Pride Provider immediately. Where damage has occurred during transport, either to the packaging or content, please contact the delivery company responsible.

MOTOR VEHICLE TRANSPORT

If you will be transporting your lift chair in a motor vehicle, individual components (external transformer, etc.) should be secured against slipping. The lift chair itself must also be secured against slipping (a possible hazard during vehicle braking).



BODY COMPONENTS

This section describes the features of your lift chair. Carefully review the function and location of each item described, and note that the illustrations and option locations shown in this manual may not reflect the type of lift chair that you own.

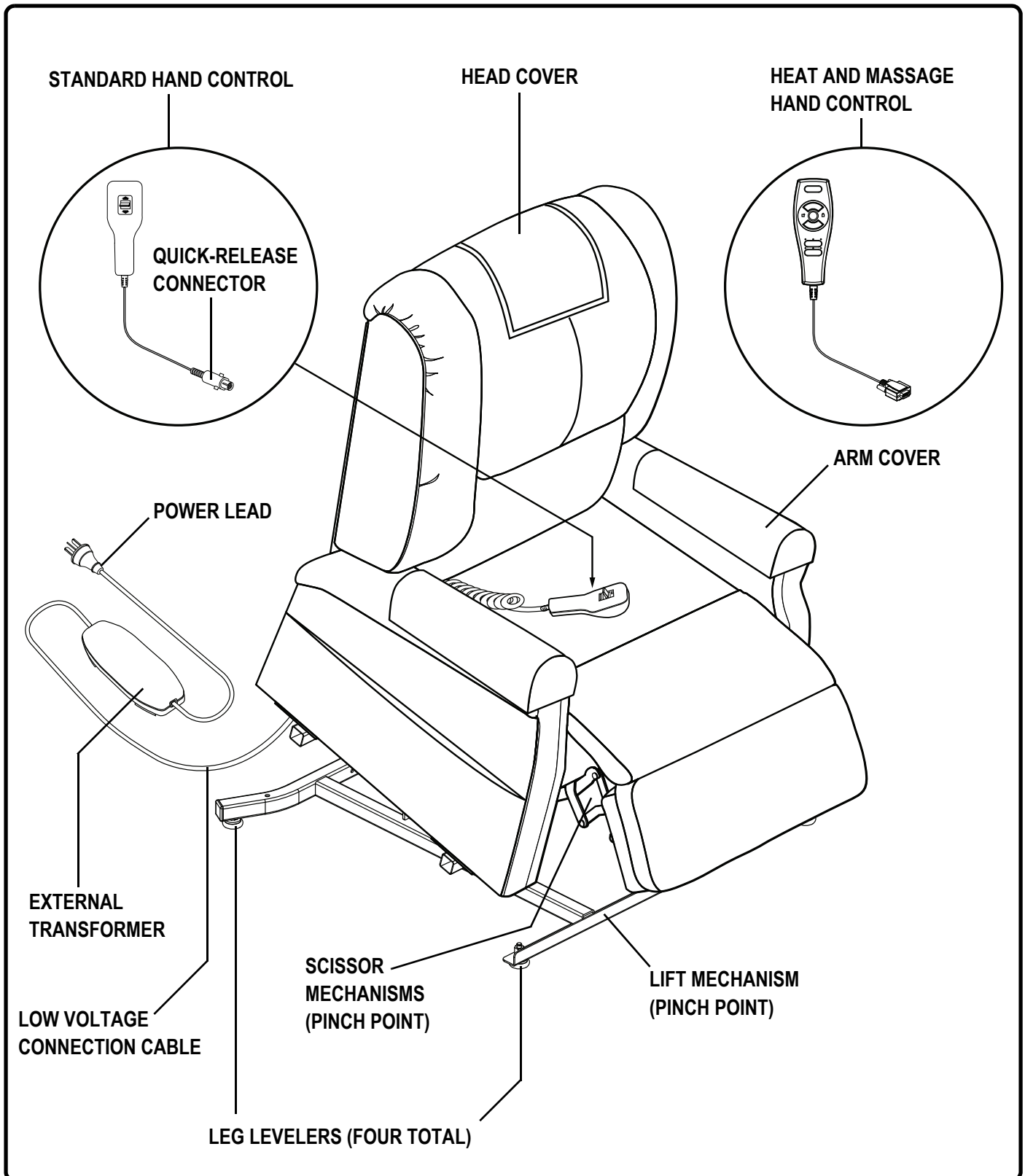

Figure 3.1 Pride Lift Chair Main Components

Lift Mechanism: Responds to the hand control commands to position the chair in the sit, recline, and stand positions.

Leg Levelers: Manually rotate up or down in order to stabilise the chair before use (Fig. 3.2).

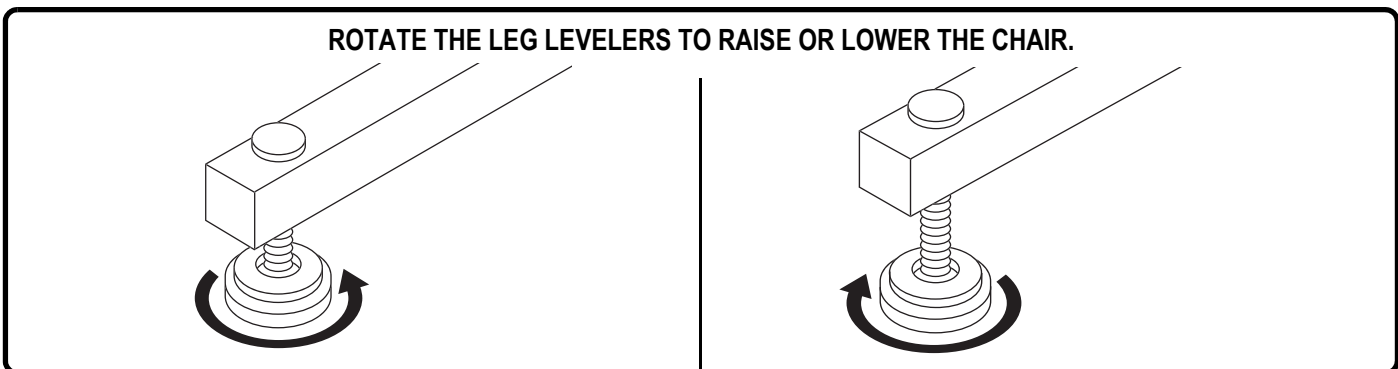

Figure 3.2 Leg Levelers

Scissor Mechanisms: Extend or retract to take the chair through the various stages of recline (Fig. 3.3).

WARNING! Pinch/Crush Points Hazard! Be aware that the lift mechanism and scissor mechanisms are a pinch point on the lift chair. Keep the following items and similar objects clear of these points when operating the lift chair:



- appendages
- small children
- pets
- wires
- oxygen tubes
- loose items, including but not limited to clothing and blankets
- electrical power leads

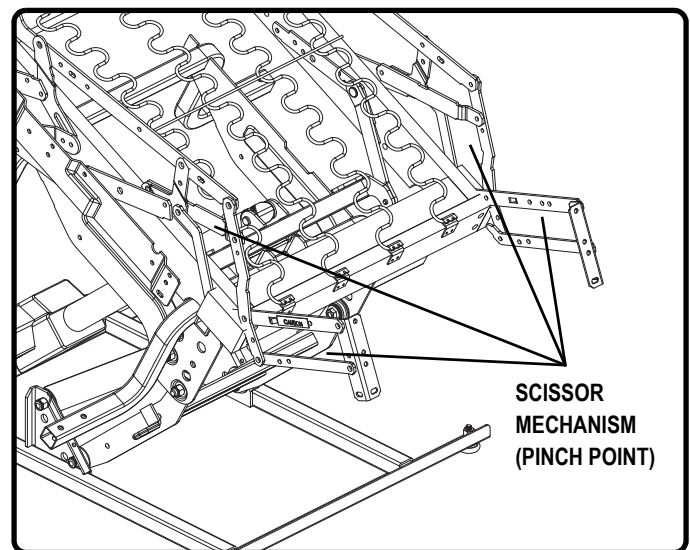

Figure 3.3 Scissor Mechanism

ELECTRICAL COMPONENTS

Your Pride Lift Chair is equipped with a low voltage DC electrical system that reduces the standard household alternating current of 100V AC - 240V AC to direct current (24/39V DC). The electrical components include the external transformer, batteries (not included), and hand control. Keep these areas free from moisture at all times.



WARNING! Keep all electrical components free from moisture at all times to prevent shock and/or electrical hazard.

External Transformer: Connects to a standard electrical outlet to provide power to the lift chair. The transformer is equipped with an LED indicator, which shows green when power to the transformer is on.

The external transformer may also come equipped with mounting brackets that allow the transformer to be mounted to the wall directly under the standard electrical outlet. The screws must be mounted to the wall stud for security. Refer to "Appendix B" for a mounting diagram.

NOTE: Pride is not responsible for damage due to improper installation.

Batteries: Provide the power needed to return the lift chair to an upright or semi-upright position in the event of a power failure. For those models equipped with a battery backup system, the batteries (not included) must be installed into the external transformer. See IV. “Assembly/Disassembly.”

NOTE: The batteries will provide power for only a short period of time after power is removed from the system, so it is important to act quickly in the event of a power failure. Engage and hold the up/down switch on the hand control as soon as possible. Maintain a steady pressure on the switch to avoid excessive draw from the battery and achieve the most amount of lift. Keep in mind that the amount of lift the batteries will be able to provide is affected by user weight and battery condition.

Hand Control: Contains the controls needed to operate the various functions of the lift chair. Refer to V. “Operation” for more information. The hand control may be equipped with a quick-release connector, which enables the user to detach the hand control from the chair, disabling all functions of the hand control.



Your lift chair may require some assembly before initial use. It may also require disassembly to make servicing the chair more convenient. If your lift chair is a Knock-Down (KD) model, follow the instructions in “Lift Chair Setup.” If your lift chair is not a KD model, proceed to “Lift Chair Placement.”

LIFT CHAIR SETUP

KD models will arrive in the knock-down position (**Fig. 4.1**).

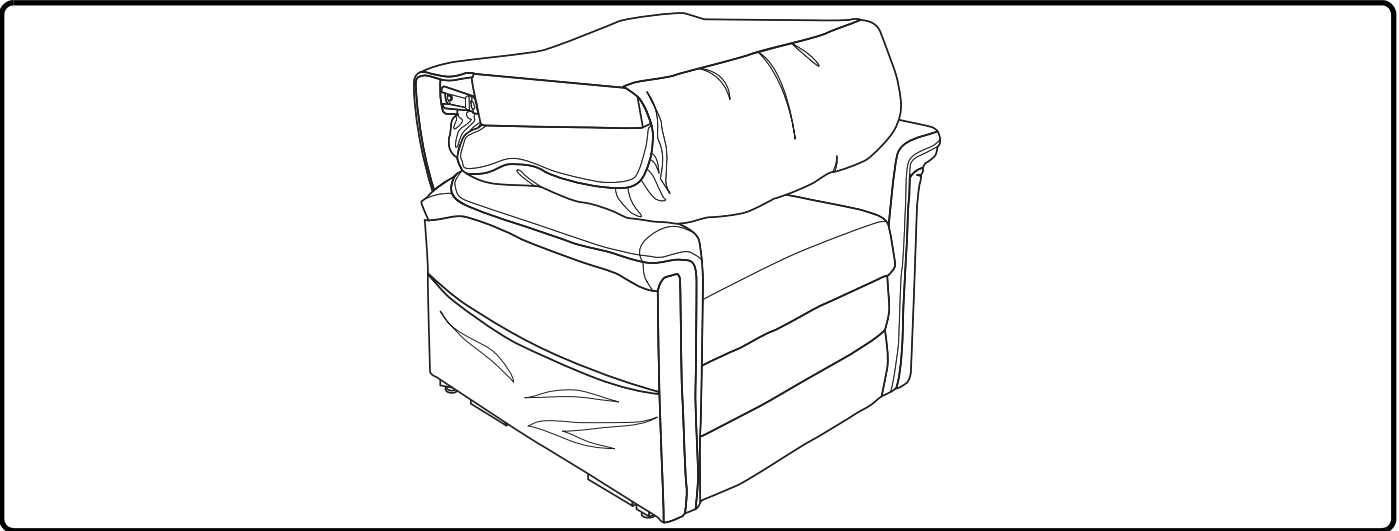
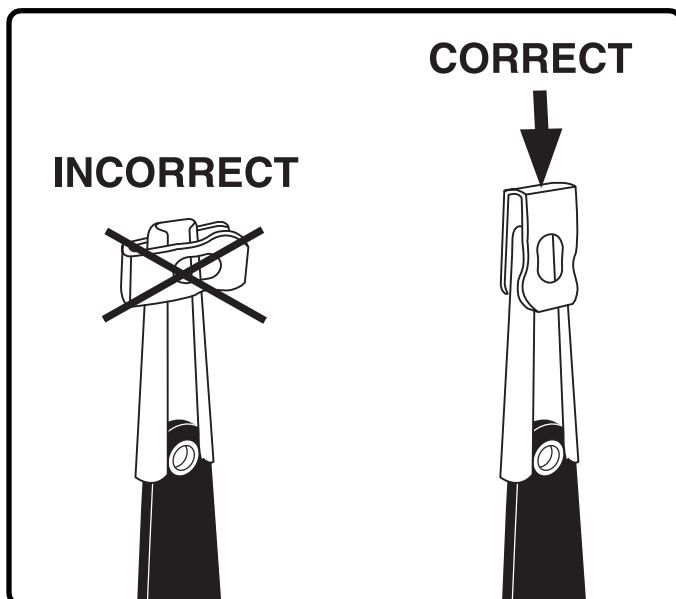
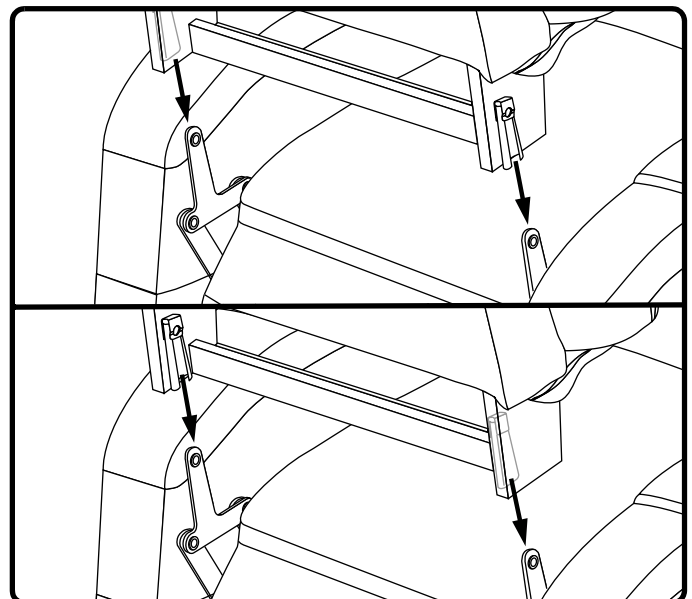

Figure 4.1 Knock-Down (KD) Position

Follow these steps to assemble the lift chair:



4.1.1 Remove the packaging from the back portion of the chair and check that the locking clip is in the vertical position. Reposition if necessary.



4.1.2 Drape the hand control and cable over the chair base, then slide the left and right KD sleeves of the chair-back onto the KD connections on the arms and seat of the chair.

NOTE: Depending on chair width, you may need to slide on one side of the chair-back at a time. If this is the case, level the chair-back before pressing down to lock into position.

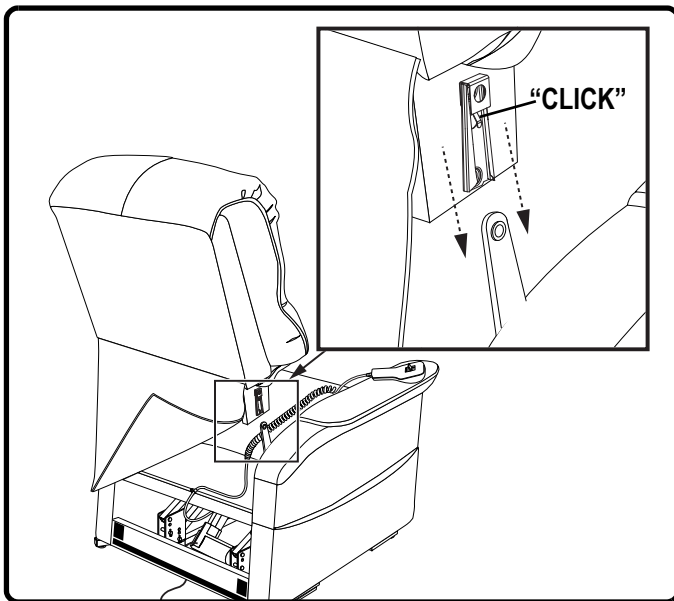

4.1.3 Push firmly on the top of the chair-back to lock into position. Listen for a click on each side to ensure the chair-back is locked in properly.

NOTE: Pull up on the chair-back to ensure that it is locked in place. If the back can be pulled off, then repeat steps 4.1.1 and 4.1.3. You must hear a click from each side of the chair.

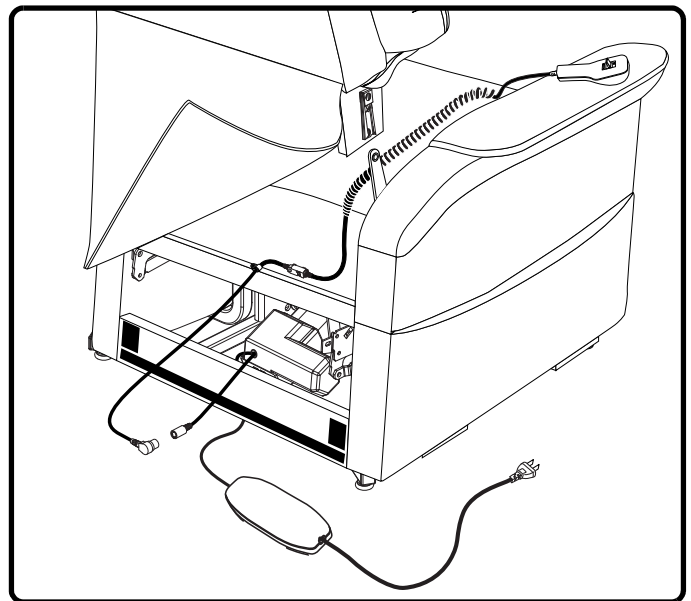

4.1.4 Connect the hand control harness to the motor. For units equipped with heat and/or massage, connect the hand control harness directly to the junction box mounted to the back of the lift chair.

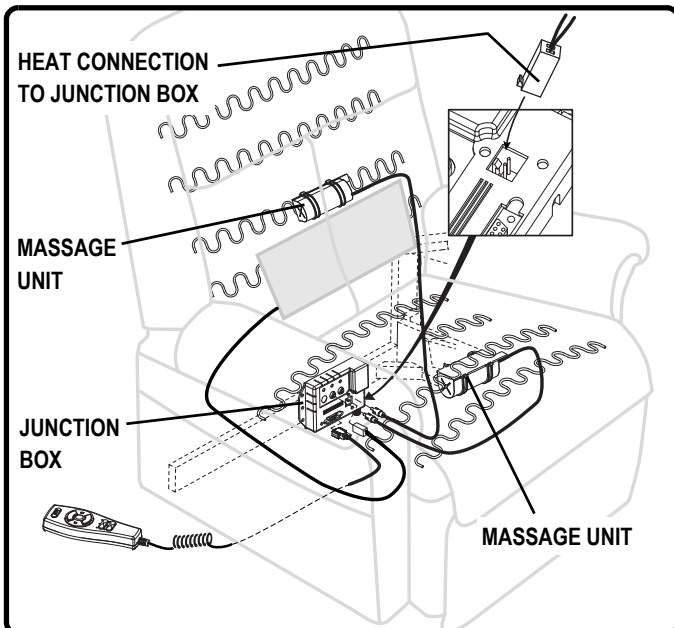

4.1.5 For units equipped with heat and/or massage options, connect the heat and/or massage harnesses to the junction box mounted to the back of the lift chair. There will be one heat connection and two massage connections.

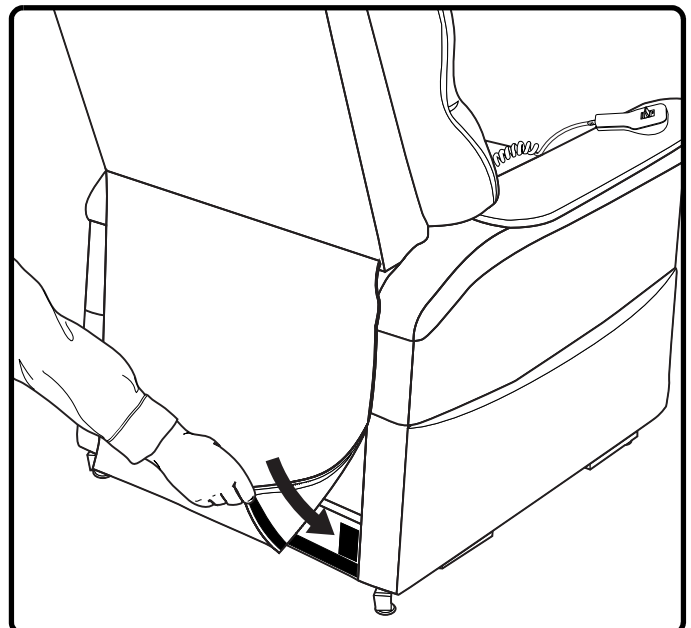

4.1.6 Attach the chair-back to the hook and loop flaps on the bottom of the chair base.

LIFT CHAIR PLACEMENT

Your lift chair should be placed near a standard electrical outlet on dry, level ground where there is ample room to allow for proper operation. Pride recommends that you have the assistance of an attendant when positioning the lift chair to avoid the possibility of injury when lifting.

Follow these steps to position the lift chair in a safe manner:

1. Place the back of the lift chair 76 cm (30 in.) from the nearest obstruction while the chair is in the seated position. This measurement may vary depending on model.
2. Adjust the leg levelers to stabilise the lift chair (**Fig. 3.2**).
3. Install the batteries into the external transformer if applicable. Refer to “Battery Installation” for more information.
4. Position the external transformer on the floor in an open, well-ventilated area where it will not be an obstruction, or if equipped, utilise the optional wall mount.
5. Position the low voltage connection cable where it will not be pinched between the frame and the lift mechanism.
6. Connect the low voltage connection cable to the external transformer if it is not already connected.
7. Plug the power lead directly into the electrical outlet. **Do not use an extension lead!**

NOTE: If you discover a problem at any point during the setup and positioning of your lift chair, stop and contact your authorised Pride Provider immediately. To avoid personal injury and/or product damage, do not plug the unit into the electrical outlet until the problem is corrected and do not attempt to fix electrical problems by yourself.

BATTERY INSTALLATION

Your lift chair may be equipped with a battery backup system that will activate during a power failure. The backup system is powered by two 9V batteries (not included) that need to be installed into the external transformer.

Follow these steps to install the batteries:

1. Unplug the external transformer power lead from the electrical outlet.
2. Open the marked battery door on the external transformer.
3. Install two 9V batteries into the external transformer (**Fig. 4.2**).
4. Replace the battery door.

NOTE: Always make sure the external transformer is equipped with two fresh 9V batteries, since the battery backup system does not recharge itself. Fresh batteries are defined as 9V alkaline batteries that are replaced every time the battery backup system is activated during a power failure, or once a year if the battery backup system has not been activated.

NOTE: If you unplug your lift chair for an extended period of time (more than one hour), remove the batteries from the external transformer. The lift chair will draw power from the batteries even when it is not in use.

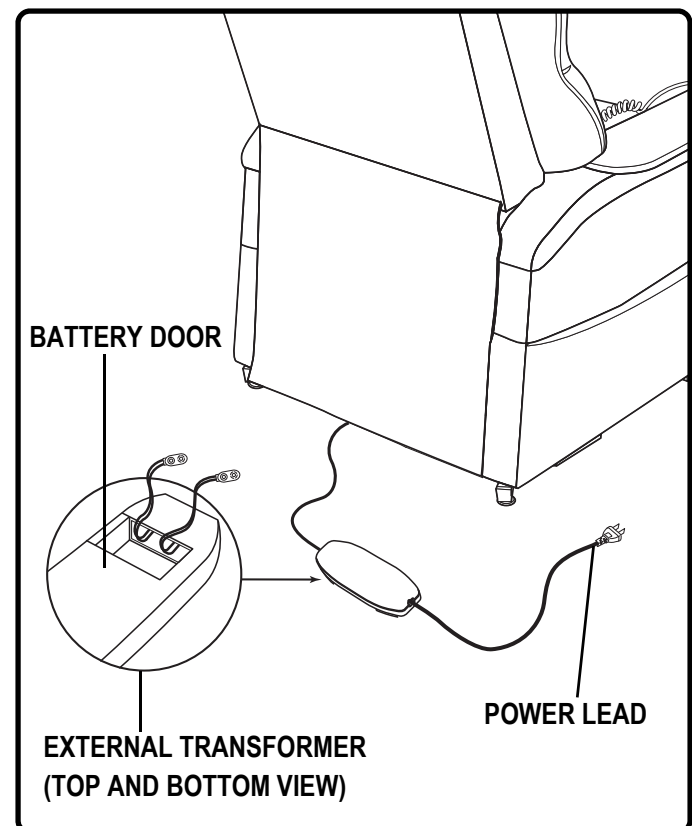
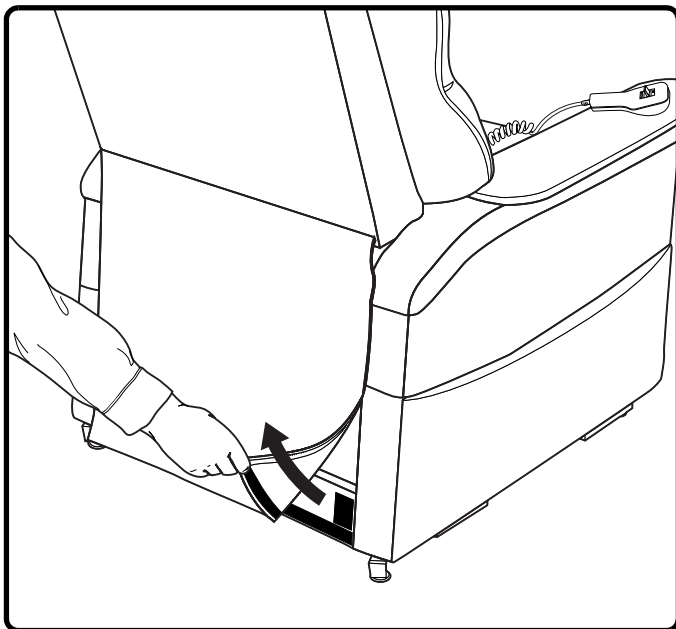

Figure 4.2 Lift Chair Battery Backup Location

LIFT CHAIR DISASSEMBLY

The back portion of KD Lift Chairs can be removed to make service and transport of the chair more convenient.

Follow these steps to disassemble the lift chair:



4.3.1 Remove the bottom of the back fabric from the hook and loop flaps on the chair base.

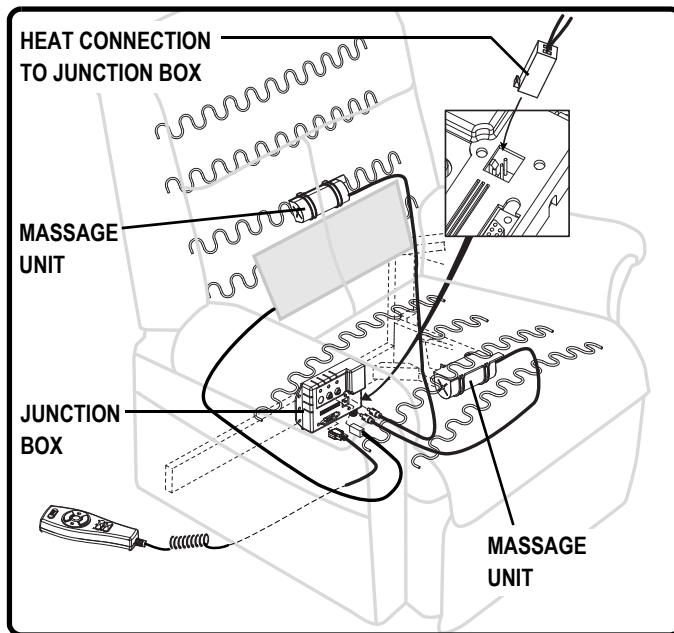

4.3.2 For units equipped with heat and/or massage options, disconnect the heat and massage connectors from the junction box.

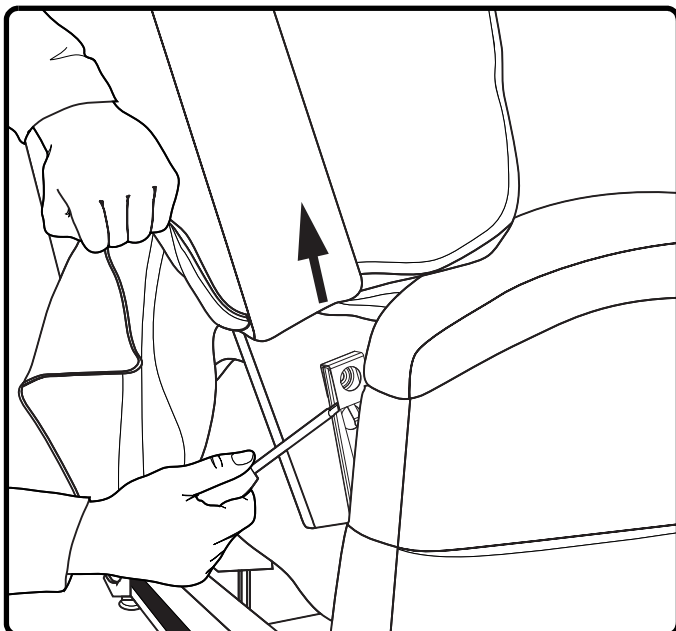

4.3.3 Using a large flat-head screwdriver, lift the left and right locking clips on the chair-back one side at a time to raise the back from the connections on the chair base. As you lift each locking clip, pull up on the chair-back to lift that side over the lock.

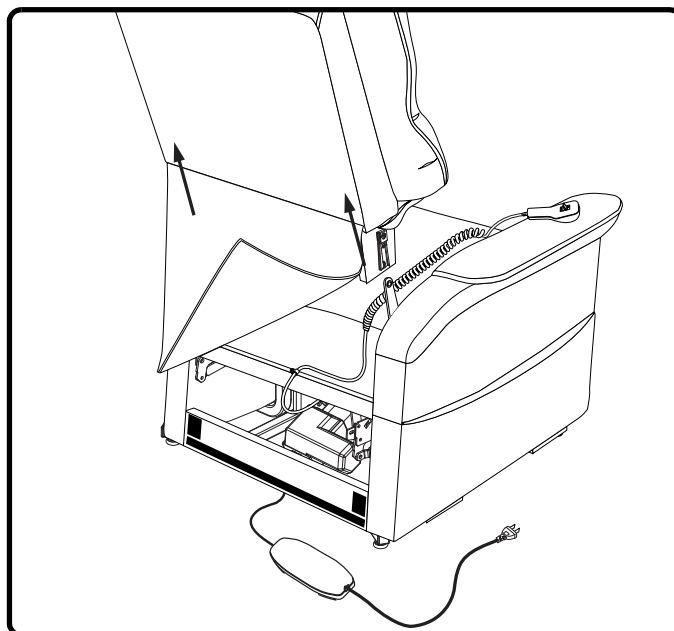

4.3.4 Lift the chair-back up and away from the chair base.



OPERATION PRECAUTIONS

There are certain precautions that should be taken during the operation of your lift chair. Read and follow these precautions carefully in order to ensure safe lift chair operation and to prevent injury and/or product damage.

- Plug the power lead directly into the electrical outlet. **Do not use an extension lead!**
- Do not place anything (for example, a drinking glass) on top of or near the external transformer.
- If the external transformer box or hand control requires cleaning, unplug the power lead from the electrical outlet and use a clean, dry cloth or lightly dampened cloth. Allow ample drying time before plugging the power lead back into the electrical outlet.
- Periodically check the hand control and all power leads for visible damage.
- Keep the hand control away from all heated surfaces.
- Ensure the hand control is out of the way before sitting in the chair.
- Keep children and pets away from all moving parts while operating the lift chair.
- Do not allow children to play on or operate the lift chair. Only the intended user should operate the lift chair.
- Keep the hand control locked or utilise the quick-disconnect feature on the standard hand control when the lift chair is not in use to prevent unintended operation of the chair.
- Avoid pinch points, such as the lift and scissor mechanisms. Keep hands and feet clear of these areas.
- Always leave the lift chair in an upright and closed position when not in use.
- Do not sit or stand on the footrest.
- Do not “drop” into the lift chair when sitting if it is in a partially raised position.



PROHIBITED! Do not place objects under the lift chair. Make sure area is clear of obstructions, including pets and small children during operation.

WARNING! Prevent the risk of electrical shock, fire, falls, and/or being pinched. Follow all instructions and precautions provided.



WARNING! Prevent potential equipment damage! Do not place the external transformer under the lift chair.

WARNING! Do not cover the external transformer. Keep the transformer in an open, well-ventilated area free from foreign material/debris to ensure proper operation.

HAND CONTROL OPERATION

Depending on lift chair model, the hand control may be equipped with switches that control the movement of the chair-back, chair base, and footrest, as well as the heat and massage options (Fig. 5.1, 5.2, and 5.3).

WARNING! Do not lean on or apply downward force to the chair-back when the lift chair is in the fully reclined position. Doing so could cause the lift chair to tip, resulting in personal injury and/or product damage.



WARNING! Do not use the footrest as a seat, or for purposes outside its intended use. Doing so could cause instability in the lift chair and place undue stress on lift chair components, resulting in personal injury and/or product damage.

WARNING! Be sure to lock or disconnect the hand control when the lift chair is not in use.

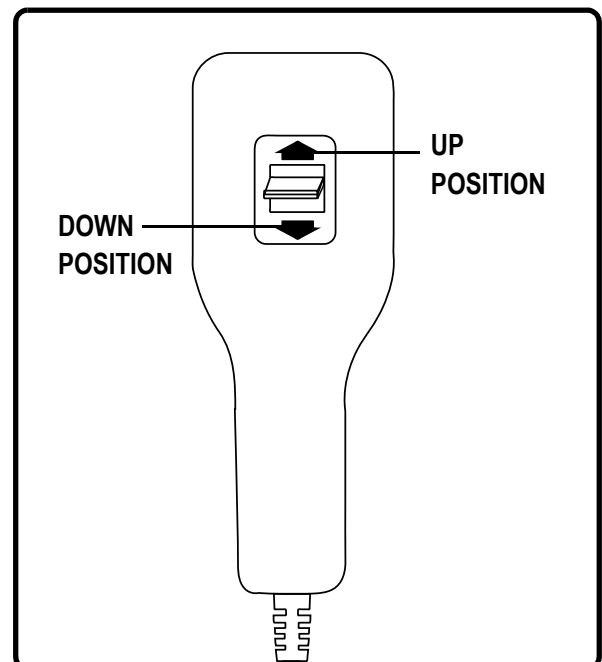

Figure 5.1 Standard Hand Control

Follow these steps to sit in your lift chair (Fig. 5.1):

1. Engage and hold the up/down switch in the UP position to raise your lift chair to the standing position.
2. Back into the lift chair and sit in the centre of the seat, using the armrests for support if needed.
3. Engage and hold the up/down switch in the DOWN position to lower the lift chair to a comfortable seated position.

Follow these steps to recline your lift chair from the seated position (Fig. 5.1):

1. Engage and hold the up/down switch in the DOWN position until comfortably reclined.
2. Engage and hold the up/down switch in the UP position to return to an upright, seated position. Release the switch when the lift chair reaches a comfortable seated position.

Follow these steps to stand up from your lift chair (Fig. 5.1):

1. Engage and hold the up/down switch in the UP position to raise your lift chair.
2. Release the switch when the lift chair reaches a height where you can stand up comfortably.

Dual Motor Hand Control Operation (LL660)**Follow these steps to sit in your lift chair (Fig. 5.2):**

1. Slide the inhibit switch to the left.
2. Engage and hold the up/down switch in the UP position to raise your lift chair from the seated position to the standing position.
3. Back into the lift chair and sit in the center of the seat, using the armrests for support if needed.
4. Engage and hold the up/down switch in the DOWN position to lower the lift chair to a comfortable seated position.

Follow these steps to recline your lift chair from the seated position (Fig. 5.2):

1. Slide the inhibit switch to the right.
2. Engage and hold the up/down switch in the DOWN position until comfortably reclined.
3. Engage and hold the up/down switch in the UP position to return to an upright, seated position. Release the switch when the lift chair reaches a comfortable seated position.

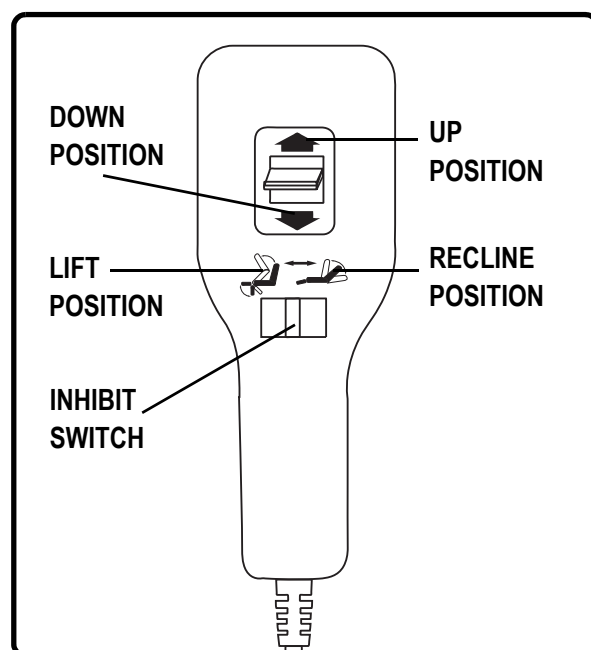
**Figure 5.2 Dual Motor Hand Control (LL660)****Follow these steps to raise or lower the footrest while in the seated or reclined position (Fig. 5.2):**

1. Slide the inhibit switch to the left.
2. Engage and hold the up/down switch in the DOWN position until the footrest is fully elevated.
3. Engage and hold the up/down switch in the UP position to lower the footrest.

Follow these steps to stand up from your lift chair from the seated position (Fig. 5.2):

1. Slide the inhibit switch to the left.
2. Engage and hold the up/down switch in the UP position to raise your lift chair.
3. Release the switch when the lift chair reaches a height where you can stand up comfortably.

Follow these steps to recline your LL770 Lift Chair to the “Trendelenburg” position from the seated position (Fig. 5.2):

NOTE: The “Trendelenburg” position is designed to elevate the legs above the head.

1. Slide the inhibit switch to the left.
2. Engage and hold the up/down switch in the DOWN position until the footrest is fully elevated.
3. Slide the inhibit switch to the right.
4. Engage and hold the up/down switch in the DOWN position until the seatback is fully reclined.
5. Engage and hold the up/down switch in the UP position to return to an upright, seated position. Release the switch when the lift chair reaches a comfortable seated position.
6. Slide the inhibit switch to the left.
7. Engage and hold the up/down switch in the UP position to lower the footrest.

Follow these steps to recline your LL770 Lift Chair to the “zero gravity” position from the seated position (Fig. 5.2):

NOTE: The “zero gravity” position is designed to disperse body weight evenly across the chair while raising the user’s legs above the torso.

1. Slide the inhibit switch to the left.
2. Engage and hold the up/down switch in the DOWN position until the footrest is fully elevated.
3. Slide the inhibit switch to the right.
4. Engage and hold the up/down switch in the DOWN position to recline the seatback until your body reaches a “V-like” position with your legs elevated higher from the ground than your torso.
5. Engage and hold the up/down switch in the UP position to return to an upright, seated position. Release the switch when the lift chair reaches a comfortable seated position.
6. Slide the inhibit switch to the left.
7. Engage and hold the up/down switch in the UP position to lower the footrest.

Heat and Massage Hand Control Operation

Follow these steps to sit in your lift chair (Fig. 5.3):

1. Press and hold the UP button to raise your lift chair to the standing position.
2. Back into the lift chair and sit in the centre of the seat, using the armrests for support if needed.
3. Press and hold the DOWN button to lower the lift chair to a comfortable seated position.

Follow these steps to recline your lift chair from the seated position (Fig. 5.3):

1. Press and hold the DOWN button until comfortably reclined.
2. Press and hold the UP button to return to an upright, seated position. Release the button when the lift chair reaches a comfortable seated position.

Follow these steps to stand up from your lift chair (Fig. 5.3):

1. Press and hold the UP button to raise your lift chair.
2. Release the button when the lift chair reaches a height where you can stand up comfortably.

Follow these steps to activate/deactivate the lock feature (Fig. 5.3):

1. Press and hold the LOCK button for approximately 3 seconds to lock the hand control. The red LED to the right of the button will light up to indicate the hand control has been locked.
2. Press and hold the LOCK button for approximately 6 seconds to unlock the hand control. The green LED to the left of the button will light up to indicate the hand control has been unlocked.

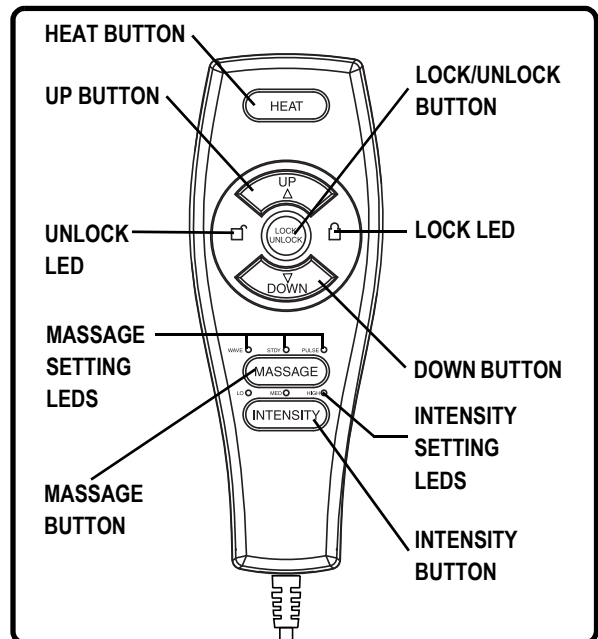

Figure 5.3 Heat and Massage Hand Control

Follow these steps to operate the heat function (Fig. 5.3):

1. Press the HEAT button once to activate the heat function. The heat function will shut off automatically after 20 minutes of continuous use.
2. Press the HEAT button again to turn off the heat function.

Follow these steps to operate the massage option (Fig. 5.3):

1. Press the MASSAGE button once to activate the massage function. This will automatically set the massage to the wave setting.
2. Press the MASSAGE button again to go to the next of three available massage settings: wave, steady, or pulse. Each press of the button will take you to the next setting. Each setting is indicated by a coloured LED.
3. Press and hold the MASSAGE button for approximately 2 seconds to shut off the massage function, otherwise this function will shut off automatically after 20 minutes of continuous use.

Follow these steps to adjust the intensity of the massage function (Fig. 5.3):

1. Press the INTENSITY button once to set the massage option to low.
2. Press the INTENSITY button again to set the massage option to the next of three available settings: low, medium, or high. Each press of the button will take you to the next setting. Each setting is indicated by a coloured LED.

NOTE: All heat units are designed with an auto-shutoff mechanism that turns off the heat after 20 minutes of use. Pride recommends that the heat and massage units not be used for more than 20 minutes at a time. However, you should consult your physician about how often you should use the heat and massage options on your lift chair.



Your Pride Lift Chair is a state-of-the-art product designed to enhance your mobility. Your lift chair should bring you years of trouble-free service, however, it may require occasional troubleshooting. The following troubleshooting tips and FAQs should summarise what you need to know about your lift chair. If at any time you do not feel comfortable performing the troubleshooting steps listed in this manual, contact your authorised Pride Provider for service. Please have the model number, serial number, and nature of the problem when calling.

FREQUENTLY ASKED QUESTIONS

What if my lift chair does not operate at all?

- Ensure the external transformer is plugged into a properly wired electrical outlet.
- Check the circuit breaker box connected to the electrical outlet to ensure the outlet is receiving power.
- Ensure the low voltage connection cable is plugged into the external transformer.
- Ensure that all cables are connected properly.

What if my lift chair operates in one direction only?

- Check the up and down buttons on the hand control to make sure the buttons do not stick. If the buttons are sticking in either position, the hand control may need to be replaced.
- Contact your authorised Pride Provider for further assistance.

What if my lift chair stops during a lifting cycle?

- Your lift chair is equipped with an internal thermal shutoff switch located inside the external transformer that prevents the motor control box from overheating. If the thermal shutoff activates, allow the lift chair to remain in a stationary position for 10 minutes to allow the motor to cool, then resume normal operation. If you notice the motors overheating frequently, contact your authorised Pride Provider.
- There may have been a power failure and/or there are no batteries in the external transformer or the batteries have no charge. Always make sure there are fresh 9V batteries in the external transformer if equipped with battery backup.
- Check the circuit breaker box connected to the electrical outlet to ensure the outlet is receiving power.

What if the heat and massage options on my lift chair do not function?

- Ensure the junction box is connected properly to the external transformer and that there is power to the transformer. A green LED will light on the transformer to indicate power.
- Ensure the heat and massage units are connected properly to the junction box at the rear of the lift chair.
- Ensure the hand control is connected properly to the junction box. If connected properly, the LEDs on the hand control will be lit.
- If any of the LEDs do not light, contact your authorised Pride Provider for further assistance.

What if my lift chair is rocking from corner to corner after I position the chair?

The floor may be uneven or the carpet may be affecting chair position. Adjust the leg levelers in the area where the chair is rocking. See III. "Your Lift Chair" for instructions on leveling your chair.

Where can I place the external transformer box?

- On the floor away from heat sources in an open, well-ventilated area where it will not be an obstruction.
- On the wall away from heat sources utilising the optional external transformer wall mount. Refer to "Appendix B."

Where do I find the serial number on my lift chair?

You can find the serial number in two locations—one is near the rear of the motor on the steel lift mechanism, the second is attached to the frame below the scissor mechanisms. The model number for your lift chair is printed below the serial number bar code.

Who do I call for service?

Contact your authorised Pride Provider for service.



Your Pride Lift Chair will require routine maintenance checks. You can perform some of these checks, but others may require assistance from an authorised Pride Provider. By following the maintenance checks in this section as scheduled, you can help ensure your lift chair gives you years of trouble-free operation. If you have any questions regarding your lift chair's care, contact your authorised Pride Provider.

FABRIC CARE

- Inspect the fabric on a regular basis for any pulls, tears, or gaps.
- Your lift chair fabric is made of 100% polyester and falls under cleaning code W. Frequent vacuuming and light brushing to remove dust and grime is the recommended cleaning method for your lift chair. If spot cleaning is required, you should use the foam from water-based cleaning agents such as mild detergent or non-solvent upholstery shampoo. Apply the foam with a soft brush in a circular motion and vacuum when dry. Pretest a small area of the fabric with the cleaning agent before using this method. If your lift chair fabric is in an overall soiled condition, use a professional furniture-cleaning service.

WARNING! Fabric should not be allowed to come in direct contact with any type of heat source, e.g., a space heater or cigarette. Personal injury or fire damage may occur.



WARNING! Pride strongly recommends that you do not smoke cigarettes while seated in or using your lift chair, although the lift chair has passed the necessary testing requirements for cigarette smoking. You must adhere to the following safety guidelines if you decide to smoke cigarettes while seated in or using your lift chair.

- Do not leave lit cigarettes unattended.
- Keep ashtrays a safe distance from the lift chair.
- Always make sure cigarettes are completely extinguished before disposal.

NOTE: Do not use solvent-type cleaners to spot clean. Do not saturate the fabric. Prevent damage to the fabric; do not expose the lift chair to direct sunlight.

ELECTRONICS CARE

- Inspect all wiring harnesses to make sure they are not damaged or frayed.
- If damage is present, unplug the lift chair and contact your authorised Pride Provider for service.
- Keep all electronics free from moisture and temperature extremes. **Pride Lift Chairs are intended for indoor use only!**



WARNING! Even though the lift chair has passed the necessary testing requirements for ingress of liquids, you should keep electrical connections away from sources of dampness, including direct exposure to water or bodily fluids and incontinence. Check electrical components frequently for signs of corrosion and replace as necessary.

DISPOSAL AND RECYCLING

Your lift chair must be disposed of according to applicable local and national statutory regulations. Contact your local waste disposal agency or authorised Pride Provider for information on proper disposal of lift chair packaging, metal frame components, fabric, electronic components, and batteries.



WARNING! Plastic bags are a suffocation hazard. Dispose of plastic bags properly and do not allow children to play with them.

**TWO-YEAR LIMITED WARRANTY**

For two (2) years from the date of purchase, Pride will repair or replace at our option to the original purchaser any of the following parts found upon examination by an authorised representative of Pride to be defective in material and/or workmanship:

- Steel Frame
- Motor
- Hand Control
- Scissor Mechanisms
- Scissor Lift Mechanism

NOTE: Pride reserves the right to replace only the part of the steel lift mechanism that may be defective.

NOT COVERED UNDER WARRANTY

The following parts are classed as wear items, which may under normal wear and tear require replacing. These items are **not** therefore covered under warranty: all fabric. Warranty will also be refused if damage is deemed to have been caused through misuse or accident for which Pride Mobility Products Australia Pty. Ltd. cannot be deemed responsible.

NOTE: Pride Mobility Products Australia Pty. Ltd provides parts only under warranty. Your Pride Provider is responsible for labour and service. Please contact your Pride Provider for information about these services and for any applicable charges.

MODEL NUMBER	WEIGHT CAPACITY (RATED)
805KD	136 kg (300 lbs.)
C15KD LC101 LC101R	147 kg (325 lbs.)
550SKD 550MKD 550LKD 560KD 570KD 585KD 660KD D30KD LC900	170 kg (375 lbs.)
555KD	272 kg (600 lbs.)



MANDATORY! Stay within the specified weight capacity of your lift chair. Exceeding the weight capacity voids your Pride Lift Chair warranty.

EXTERNAL TRANSFORMER OPTIONAL WALL MOUNT DIAGRAM

Cut out this diagram (1:1 scale) and use to mark area of placement for the external transformer.

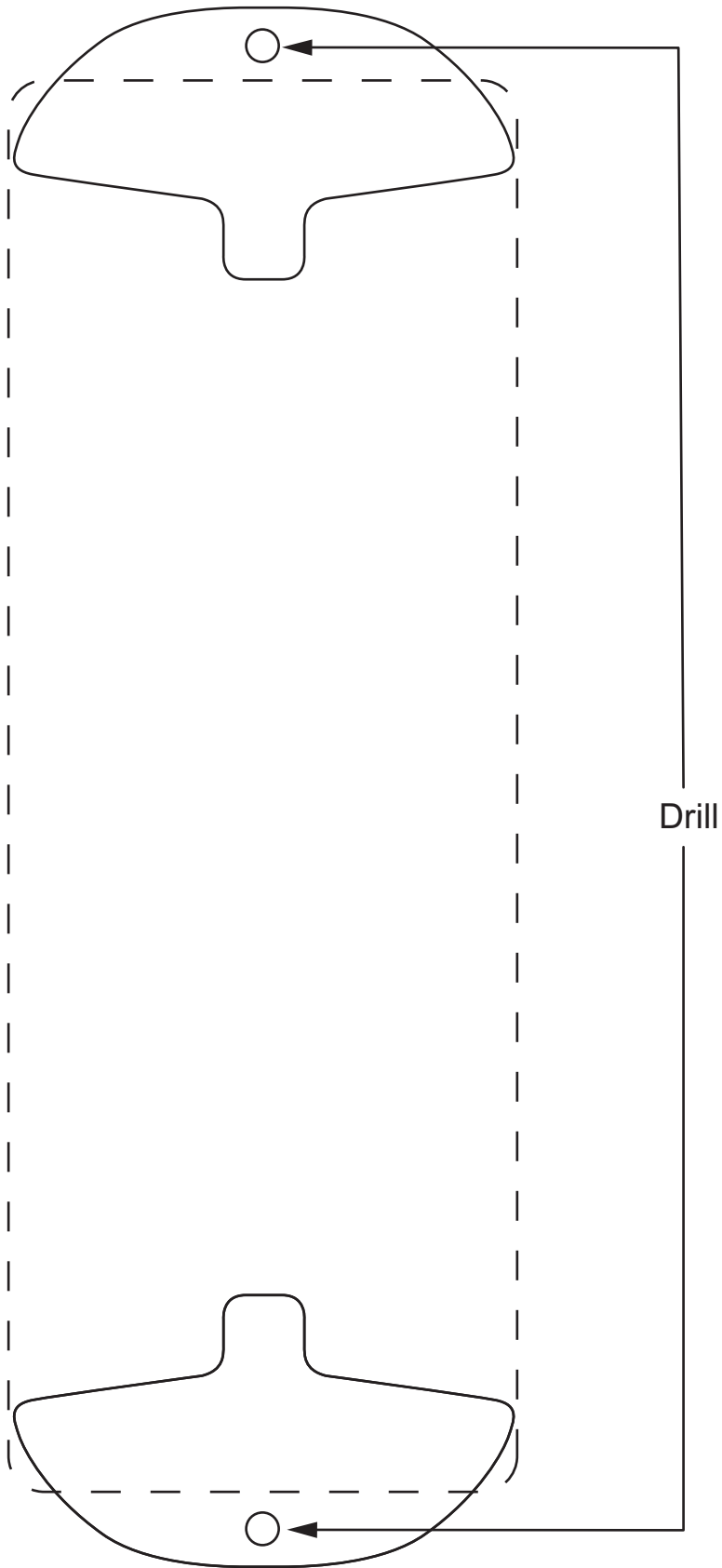

(This page intentionally left blank.)

