



SEFES

ARQMAT



SEFES



SEFES-101 OPEN ARMS



SEFES-102 CUPHOLDER



SEFES-103 WRITING TABLET



SEFES-111 CLOSED ARMS

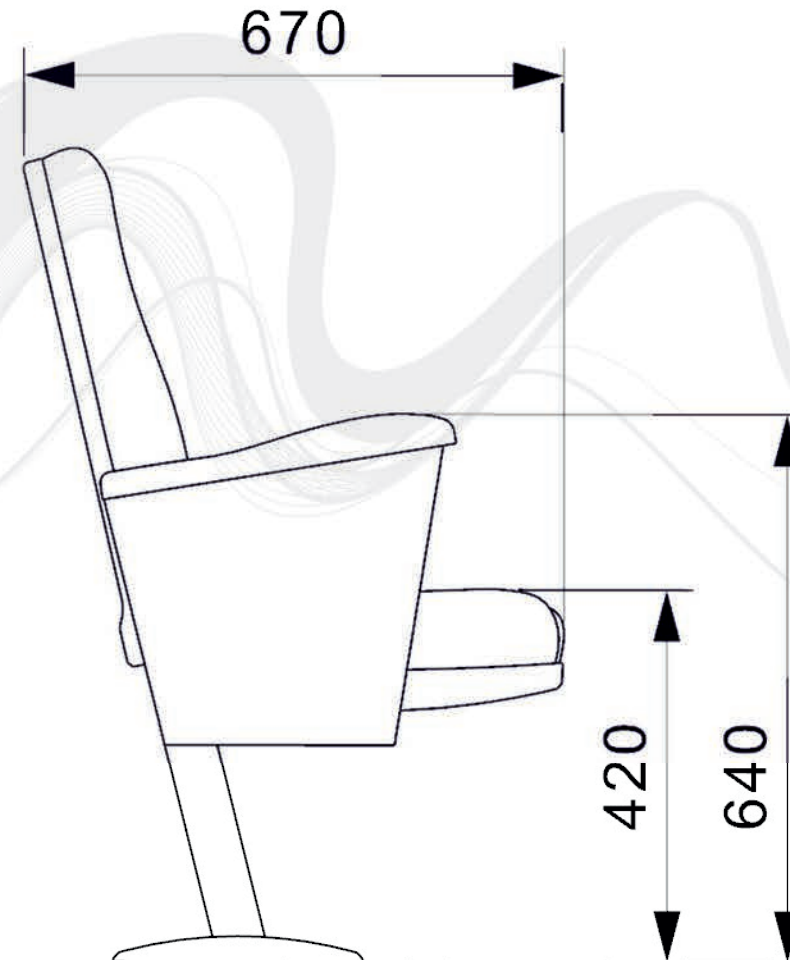
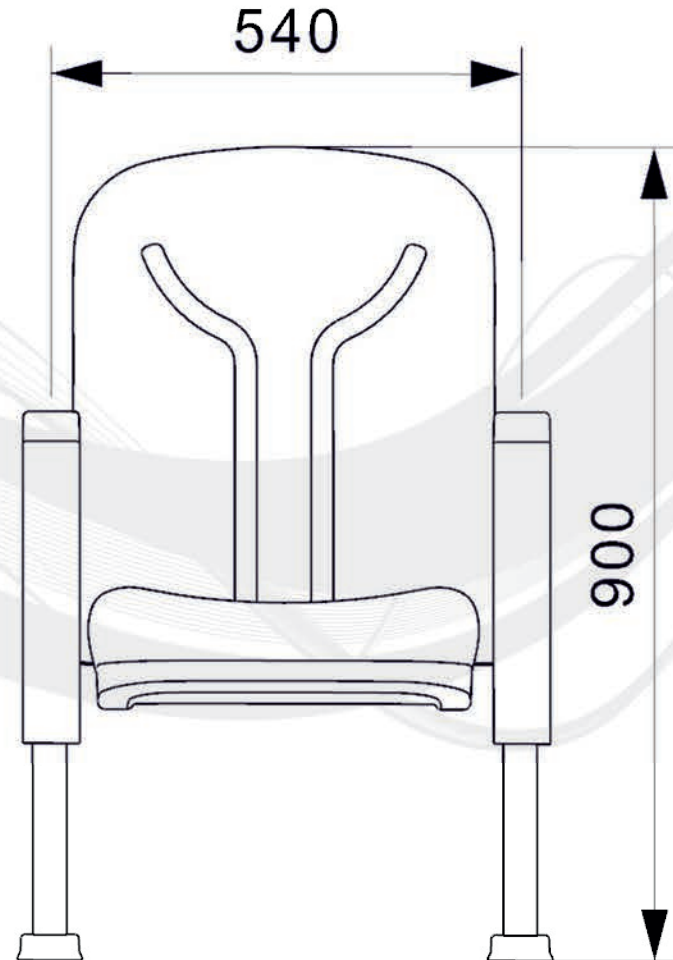

SEFES



SEFES-112 CLOSED WOOD ARMS



SEFES-113 CLOSED ARM WITH WRITING TABLET



SEFES-121 CLOSED ARMREST

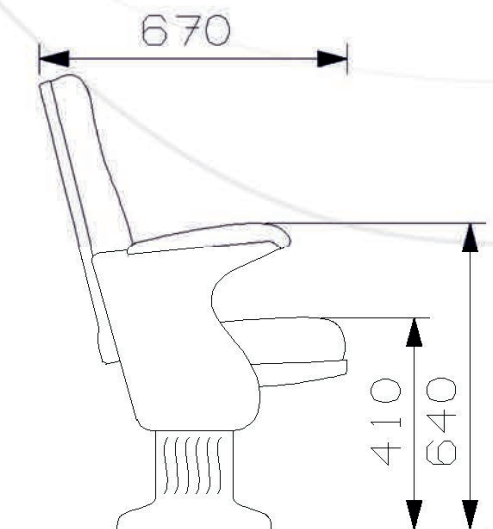
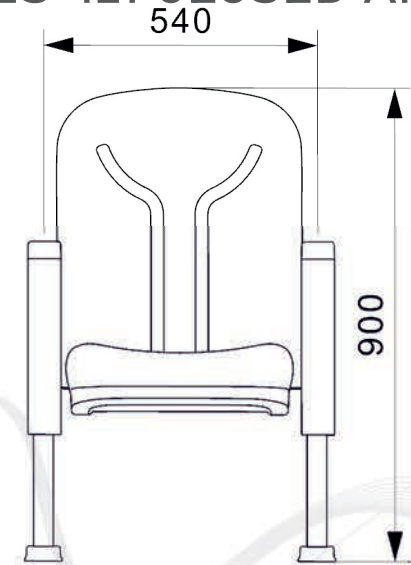
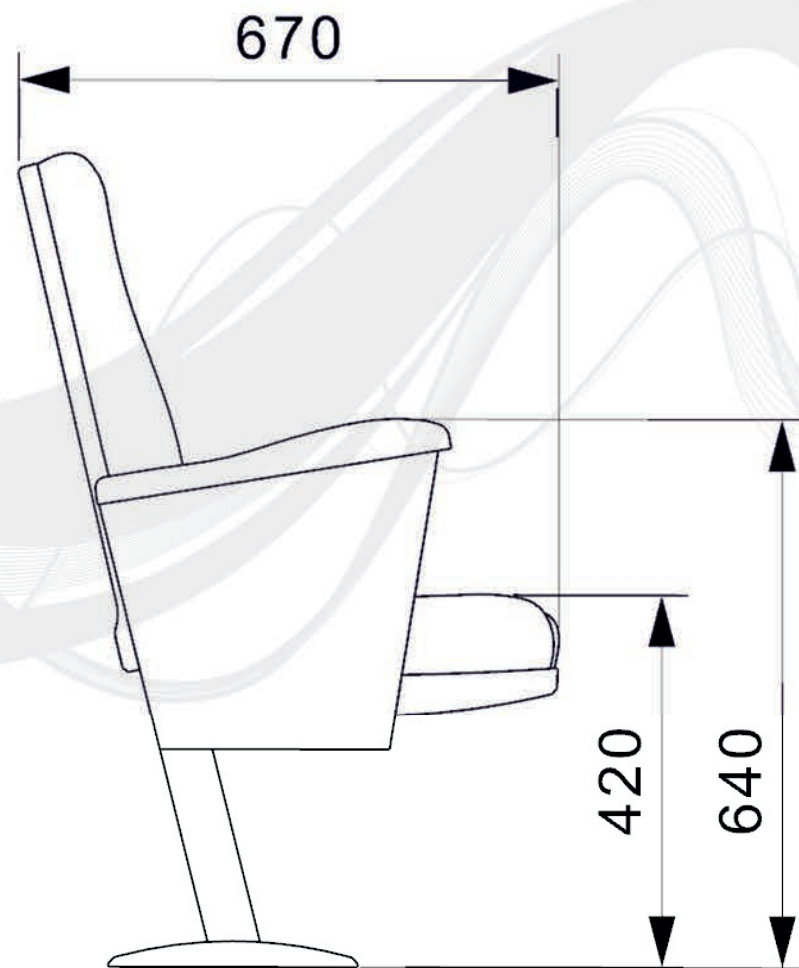
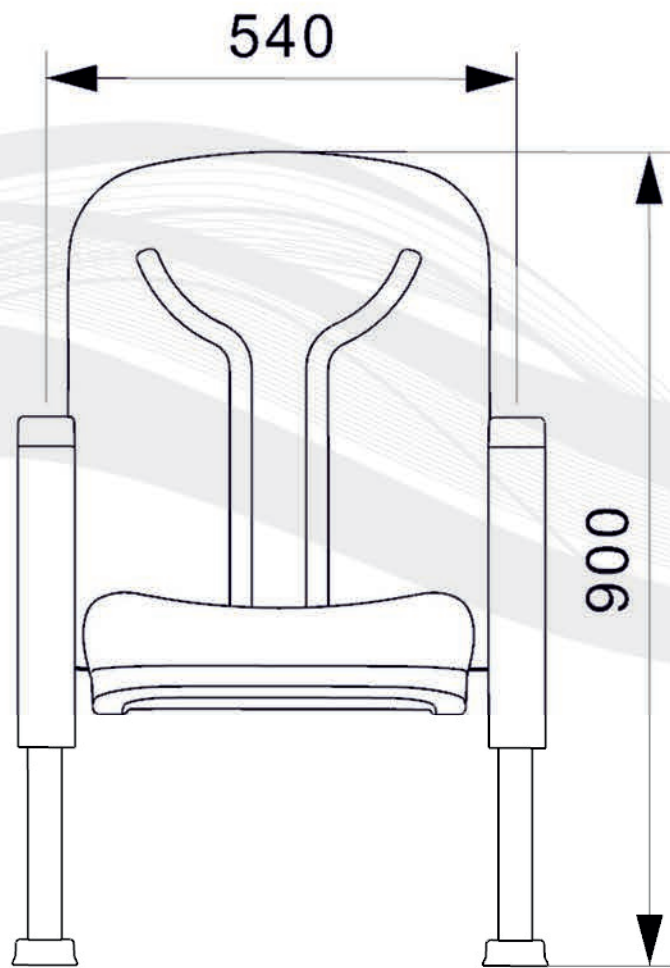

SEFES TECHNICAL DATASHEET

Seat and Backrest Units

Seating and back units of the seats are manufactured from polyurethane material in aluminum molds designed in accordance with human anatomy, in compliance with 50 + - 10% density and Mvss 302 fire standards.

Inside the seat and back pads, there is durable steel frame.

Tip up mechanism works with gravity without any springs.

Legs and Armrest Units

The side legs are manufactured from 40 x 60 x 1.5 mm steel tubes, and the parts fixed on floor are made of sheet steel thickness 2 mm.

Plastic armrests mounted on legs are durable and resistant to impact.

Seats share common arms in between.

Seats are fixed to the floor on two points for each leg.

Fabric or Vinyl

Fabric or Vinyl used for upholstery is resistant to friction, fire and UV.

Seats and back foams of the seats are upholstered with fabric or vinyl of specified specifications and durable plastic cover with acoustic holes is mounted underneath both units.

Our products have TS EN 12727 & TSE EN 13200-4 certificates and our company has ISO 9001:2015 Quality Management System.

Seat design is protected by Utility Model Registration and Petty Patent.

