



DELTA TIP UP

ARQMAT



Long-lasting



Waterproof



Virgin Material

DELTA TIP UP

*Practical solution for low steps.



STANDARD - 101



L ASSEMBLY-110



FLOOR MOUNTED-201

FRONT VIEW

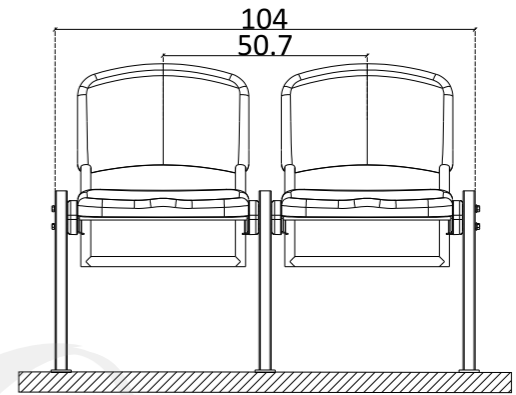
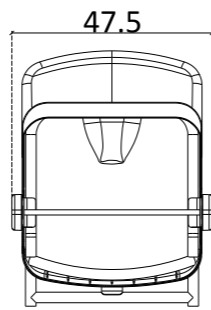
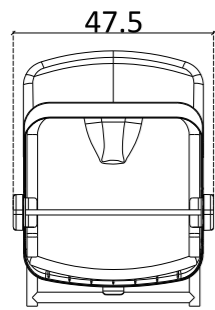

OPEN-CLOSE VIEW

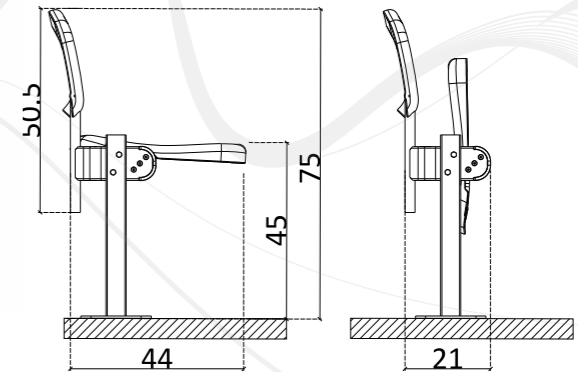
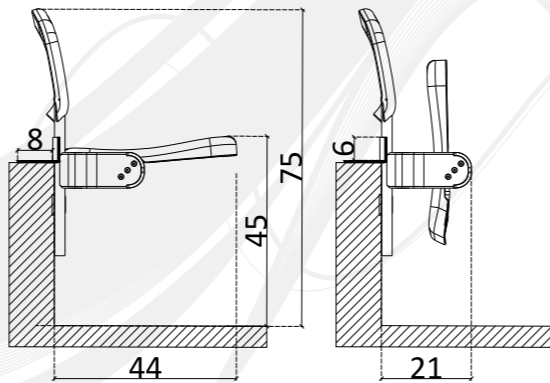
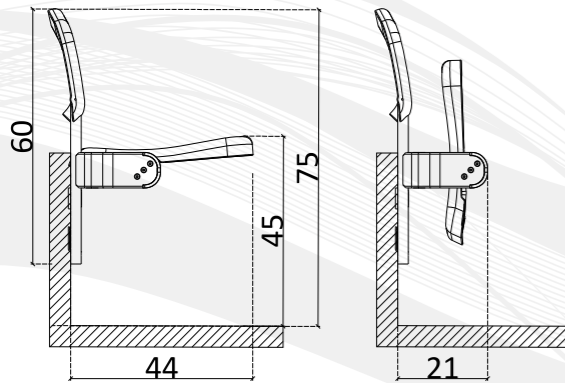

SIDE VIEW

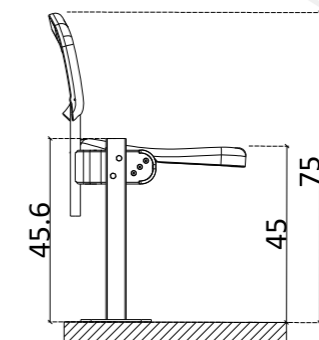
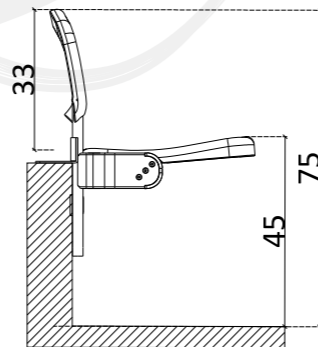
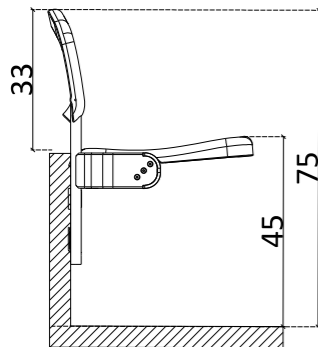

*All dimensions are centimeters.

DELTA TIP UP



FLOOR MOUNTED WITH ARMS-202

FRONT VIEW

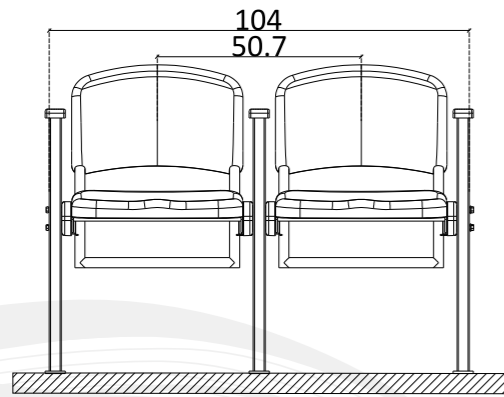

OPEN-CLOSE VIEW

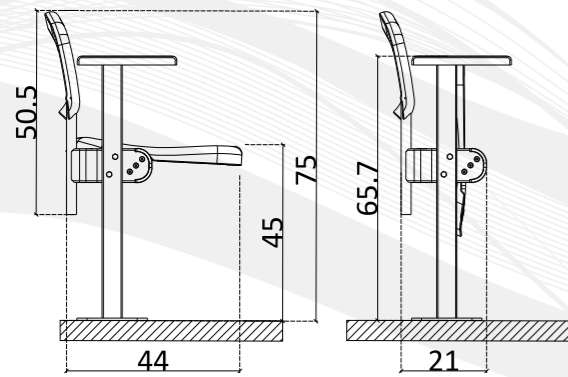

SIDE VIEW

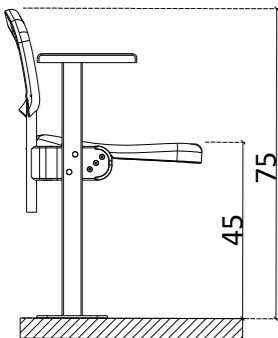

*All dimensions are centimeters.



FLOOR MOUNTED WITH MIDDLE LEG-211

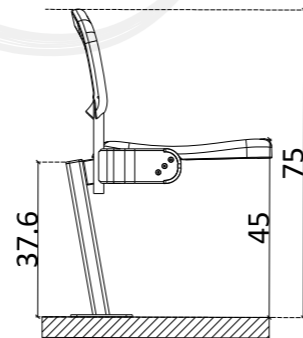
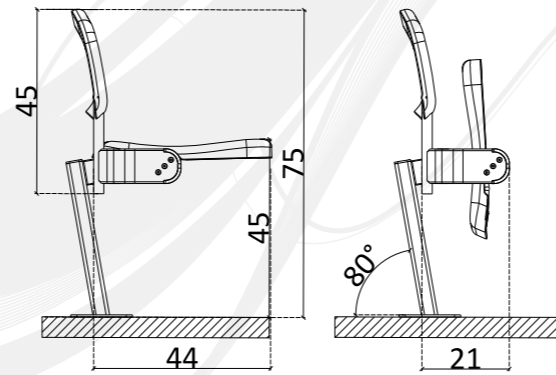
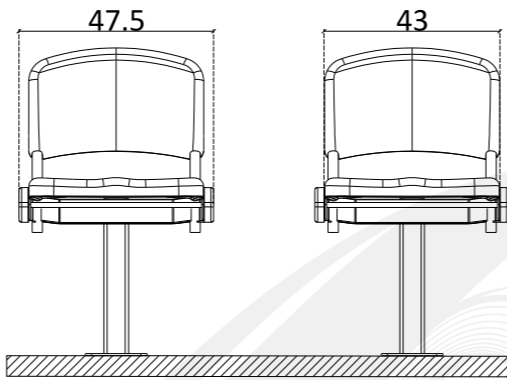

TELESCOPIC - 501

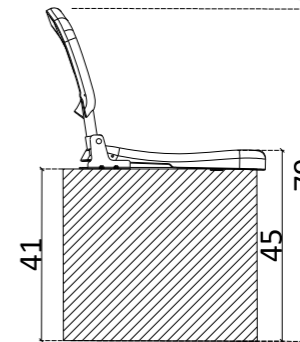
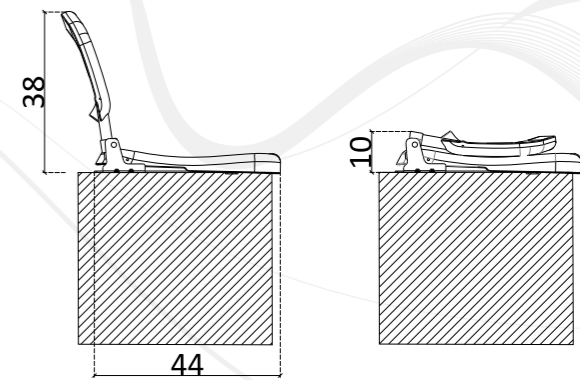
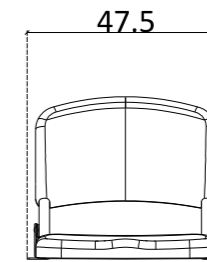

DELTA TIP UP

- ⚡ Plastic Seat and Backrest are produced by high quality copolymer P.P moulded by injection; metal frame produced by 25Qx2 mm steel frame.
- ⚡ UV and Antioxidant additives are used in color masterbatch with highest light-fastness color pigments to prevent color fade. (Light Resistance – EN ISO 4892-2)
- ⚡ FR (fire retardant) additive is used to delay inflaming. Classified as UL94 V2 standard.
- ⚡ Tip up mechanism works with counterweigh which has been concealed inside the frame .
- ⚡ In order to prevent friction between moving parts and noise, polyamide mechanism is used on both sides.
- ⚡ Orthopedic seating feature, which is comfortable for both the back and legs.
- ⚡ There is oval numbering place on backrest of the seat.
- ⚡ Surface of steel frame is sandblasted and undercoated before color is applied. Outdoor qualified powder is used in coating. Frame is tested with 500 hours Neutral Spray Fog test.
- ⚡ Seat can be mounted directly on step or floor to reach 45 cm seat height with alternative assembly methods. Assembly is made on 3 points after placing galvanised dowels on drilled holes with M8 stainless steel screws.

Our products have TS EN 12727 & TSE EN 13200-4 certificates and our company has ISO 9001:2015 Quality Management System.

