

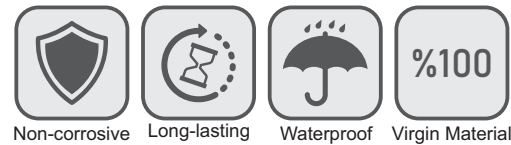

DELTA

ARQMAT



Non-corrosive Long-lasting Waterproof Virgin Material

# DELTA



## Assembly Scheme (Concrete Surface)

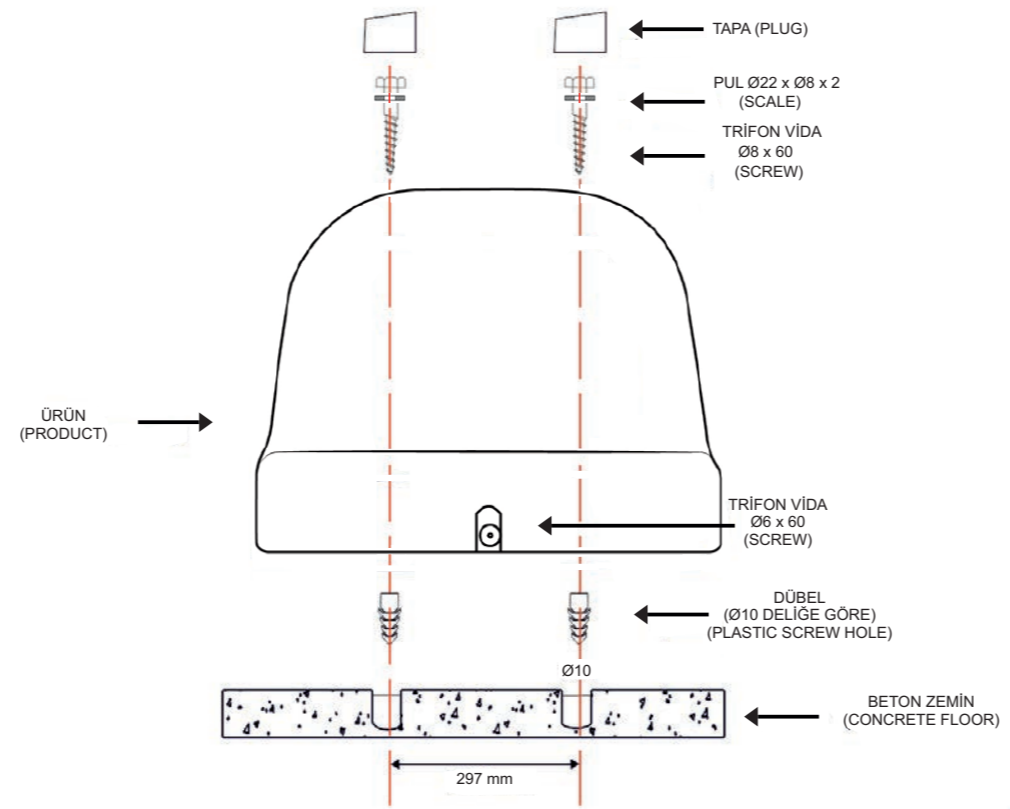

## Assembly Scheme (Metal Surface)

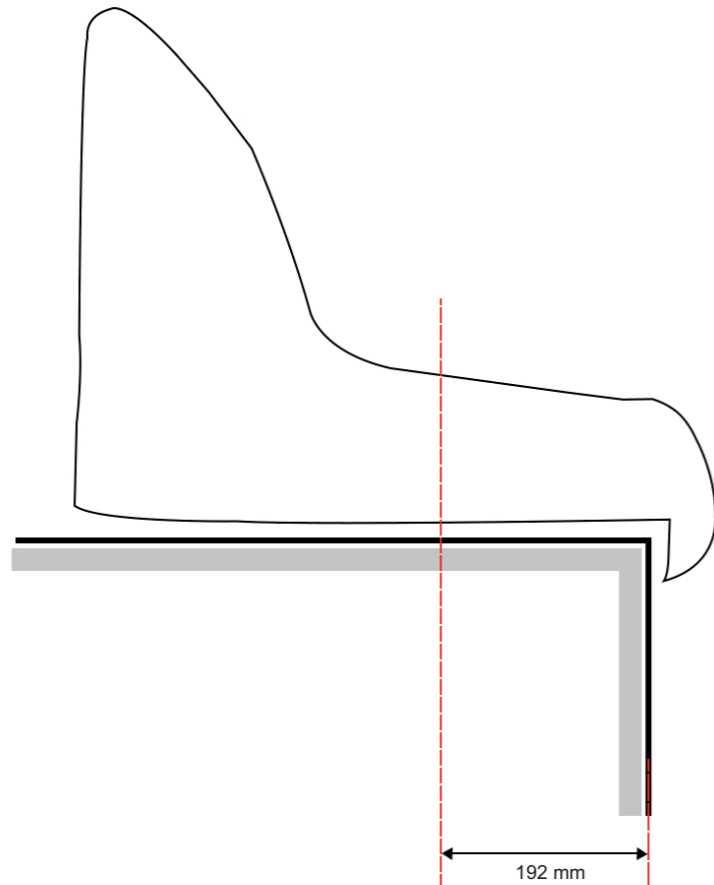
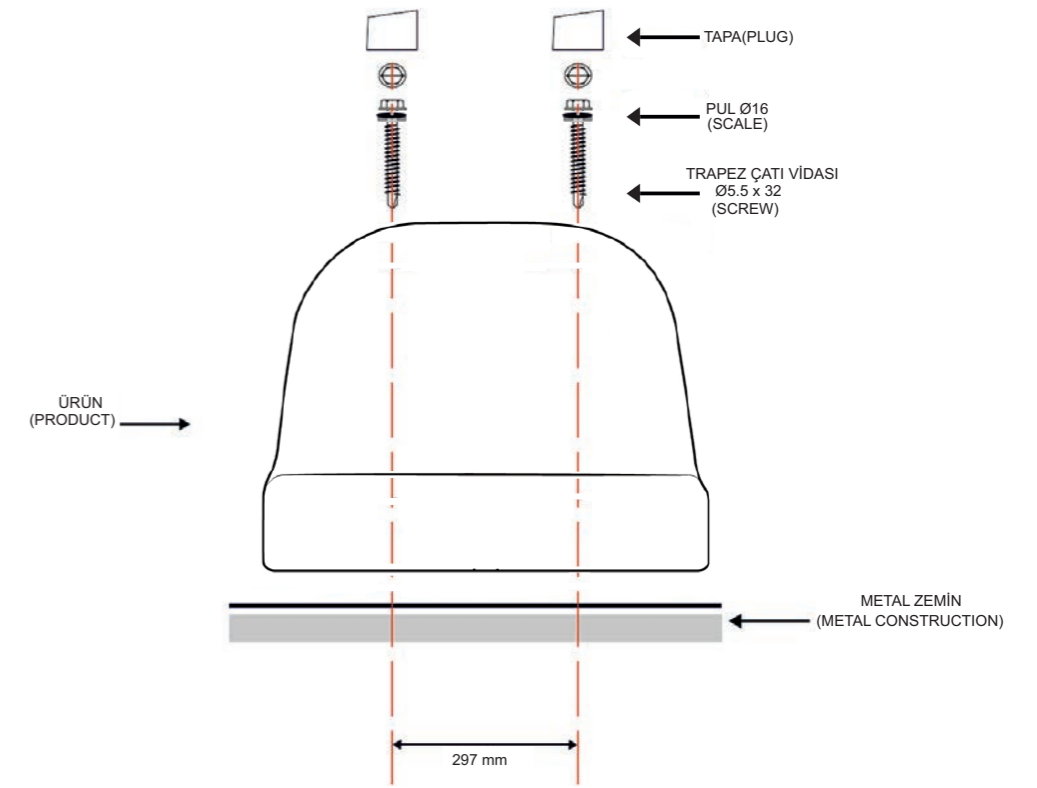

# DELTA TECHNICAL DATASHEET



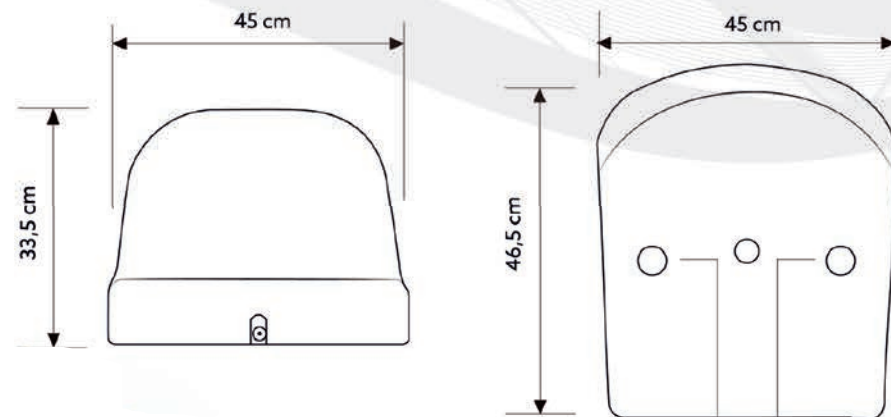

- ⚡ Seat is moulded by injection in virgin high quality copolymer polypropylene.
- ⚡ Backrest is strengthened with double wall to prevent to be broken with vandalism.
- ⚡ UV and Antioxidant additives are used in color masterbatch with highest light-fastness color pigments to prevent color fade. ( Light Resistance - EN ISO 4892-2)
- ⚡ Orthopedic seating feature, which is comfortable for both the back and legs.
- ⚡ There is a central drainage point which enables water go through.
- ⚡ Shiny surface prevent dirt from accumulating inside the seats. Easy to clean.
- ⚡ FR (fire retardent) additive is used to delay inflaming as required. Classified as UL94 V2 standard.
- ⚡ Front design does not allow the seat to be pulled off.
- ⚡ Seat is fixed onto the floor with 2 bolts and onto the step with 1 bolts after opening holes and placing dowels. The base and anchoring points of the seat are strengthened with additional ribs. Plastic caps placed on seat prevent water leaking inside the bolts.

Our products have TS EN 12727 & TSE EN 13200-4 certificates and our company has ISO 9001:2015 Quality Management System.



3 Assembly Points



			
package quantity	package dimension	40" container	90m <sup>3</sup> truck
9 Pieces	44x46.5x91 cm	2200 Pieces	3000 Pieces