



BETA

ARQMAT



-  Non-corrosive
-  Long-lasting
-  Waterproof
-  %100 Virgin Material

BETA



STANDARD-100



RISER MOUNTED-101



FLOOR MOUNTED-201

TOP VIEW

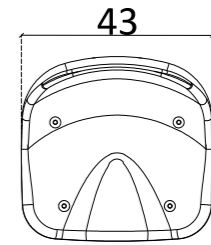
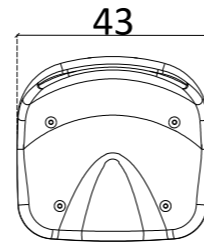
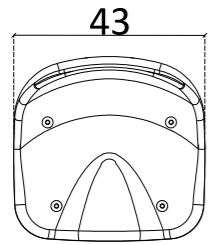

SIDE VIEW

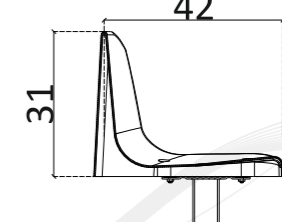
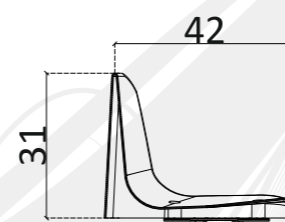
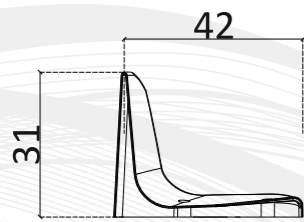

ASSEMBLY

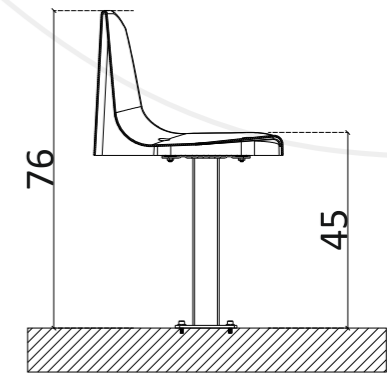
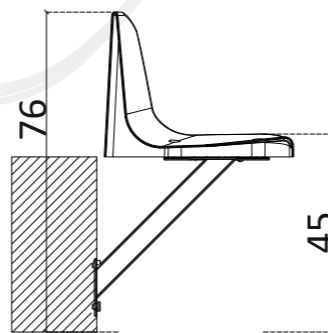
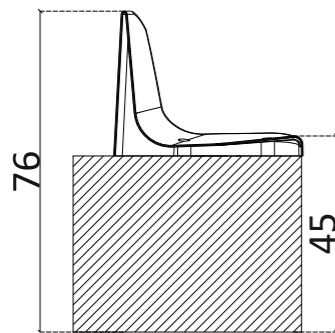

*All dimensions are centimeters.

BETA

ASSEMBLY SCHEME

Assembly Scheme(Concrete Surface)

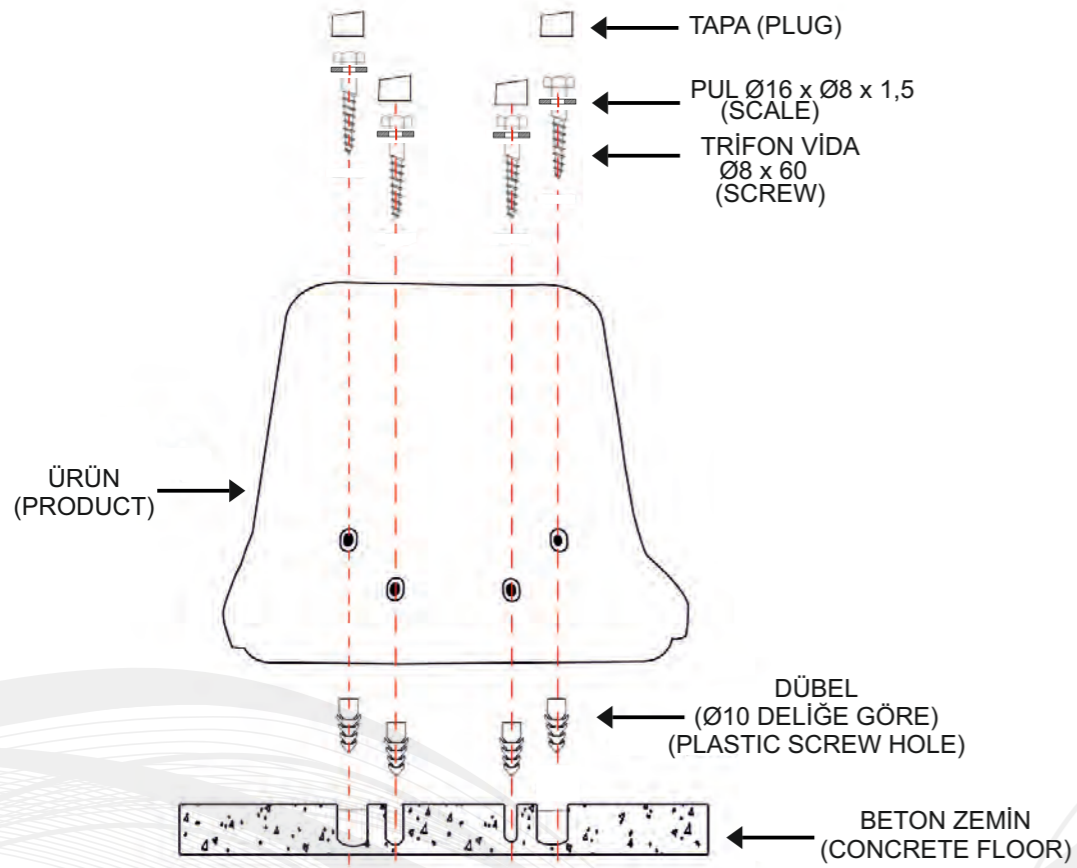

Assembly Scheme(Metal Surface)

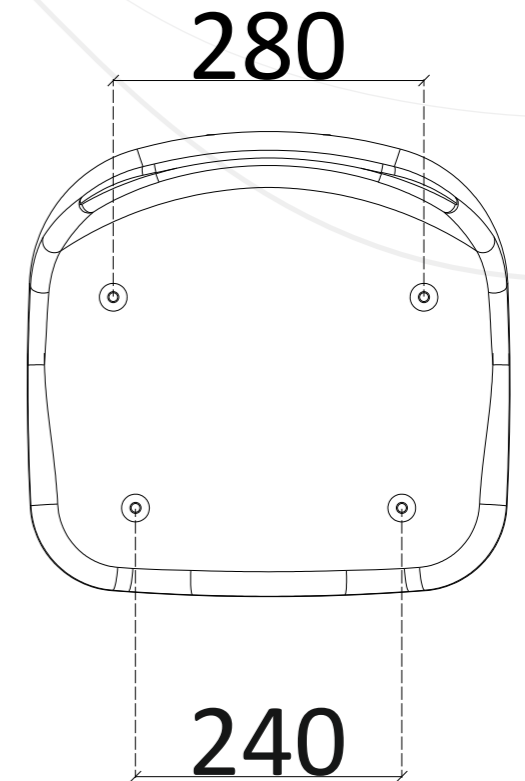
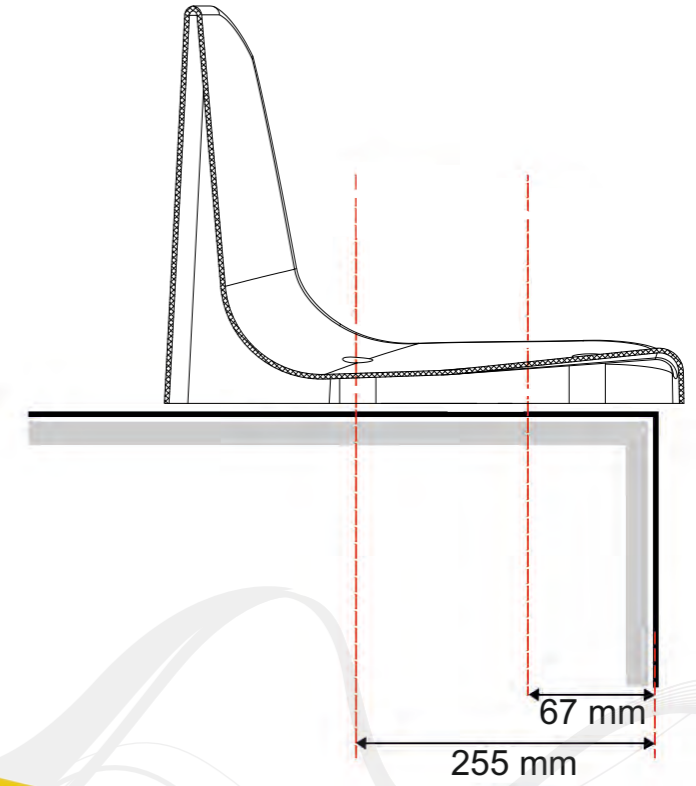
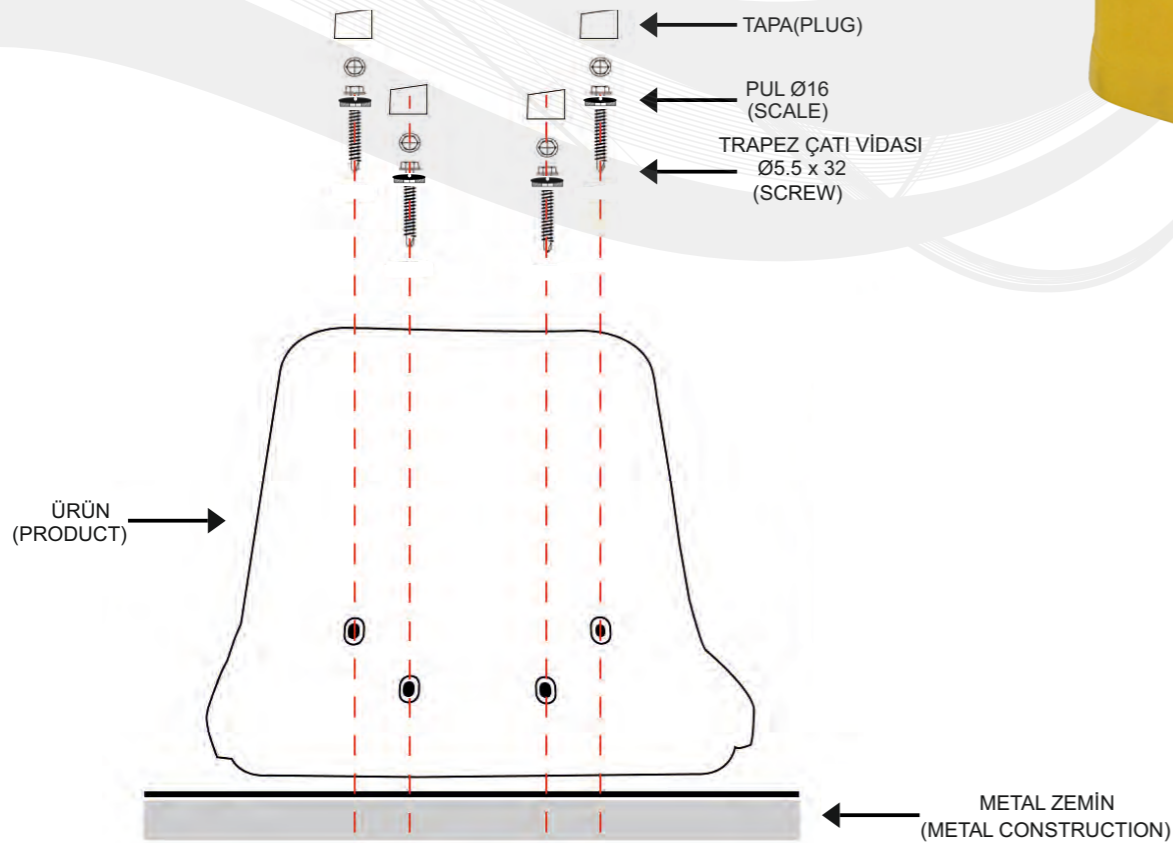

BETA TECHNICAL DATASHEET



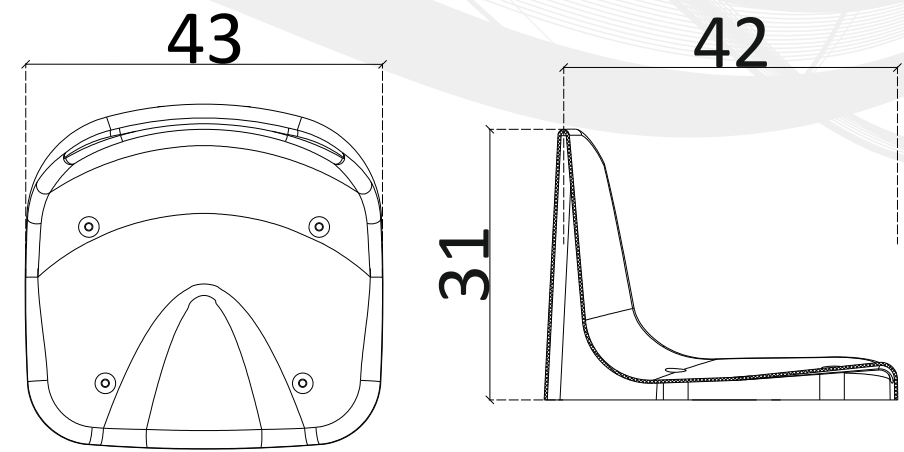

- ⚡ Seat is moulded by injection in virgin high quality copolymer polypropylene.
- ⚡ Backrest is strengthened with double wall to prevent to be broken with vandalism.
- UV and Antioxidant additives are used in color masterbatch with highest light-fastness color pigments to prevent color fade. (Light Resistance - EN ISO 4892-2)
- Orthopedic seating feature, which is comfortable for both the back and legs.
- ⚡ Ergonomical base allows correct drainage of fluids with its downward slope.
- ⚡ Shiny surface prevent dirt from accumulating inside the seats. Easy to clean.
- ⚡ FR (fire retardant) additive is used to delay inflaming as required. Classified as UL94 V2 standard.
- ⚡ Front design does not allow the seat to be pulled off.
- Seat is fixed onto the floor with 2 bolts after opening holes and placing dowels. The base and anchoring points of the seat are strengthened with additional ribs. Plastic caps placed on seat prevent water leaking inside the bolts.

Our products have TS EN 12727 & TSE EN 13200-4 certificates and our company has ISO 9001:2015 Quality Management System.



4 Assembly Points



			
package quantity 15	package dimension 42.5x42.5x105 cm	40" container 5350	90m ³ truck 7000