

DAVINCI

BODYFRIEND
Massage Chair
DAVINCI
User Manual

$$\frac{a+b}{a} = \frac{a}{b} = \phi \approx 1,61803$$

Every obstacle is overcome by persistence.
— Leonardo da Vinci



315

225

$$\frac{a+b}{a} = \frac{a}{b} = \phi \approx 1,61803$$

Greetings

Thank you for purchasing the DAVINCI massage chair of BODYFRIEND.

Before using our product, please read through the safety precautions and operation instructions carefully. We kindly ask users to understand that there may be slight differences in image and content descriptions presented throughout this manual due to product quality improvements. Thank you.

- ※ Please read the safety precautions first and use the product appropriately.
- ※ Please keep this manual in a place where users can access and read it at any time.
- ※ The product image or content descriptions may change due to product improvements without prior notice.

Product Features



Collaboration with ITALDESIGN



XD PRO



Mental Massage



Meditation Massage



Measuring Body Composition



Quick Button for Hand Acupressure Unit

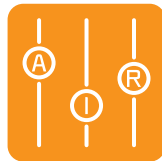

Adjust Airbag Intensity by Body Area



Healthcare massage



3STEP Sole Rolling



3STEP Adjust Zero Gravity Angle



8.7-inch Tablet Controller



Object Detection Sensors



4-channel Bluetooth Speaker



Internal Key Controls



Warm Heating

Body Composition Massage

Measure body composition and provide customized massage accordingly.

Adjust Zero Gravity Angle by Level

This button will move the body into the zero gravity position, which is an ideal posture for massage and adjustable to three angle levels.

Ergonomic 3D Frame

S-frame and L-frame provide roller massage customized to the user's body contour.

Table of Contents

	Product Features	02
Instructions Before Use	Safety Precautions	06
	Components and Descriptions	14
How to Connect	How to Connect the Product Moving and Installation	16
Controller Information	Tablet Controller Operation and Program Description	17
Special Function Information	XD PRO Module Description	31
	Brain Massage Program	32
	Mental Massage Program	34
	Meditation Massage Program	35
Product Specifications	Product Size and Specifications	36
Customer Service and Troubleshooting	Troubleshooting Guides	37
	Customer Service Descriptions related to the Tablet	38
	Massage Chair Customer Support Guidelines	39
Product Warranty	Warranty Terms and Conditions	40

Safety Precautions

- ※ The descriptions below are for using the product safely and accurately to prevent any unexpected risk or damage.
- ※ The safety precautions have two categories below depending on the expected risk and damage, and urgency if used incorrectly:



Warning

To reduce the risk of any product deformation, malfunction, safety accidents, product damage, mold, fire, electric shock, or physical damage



Caution

To reduce the risk of physical damage

Tablet Controller Precautions



Warning

- **In case of fire or explosion, the product may be damaged and the user may be injured from the accident.**
- The product has magnetics inside. Keep a safe distance between the product and your personal effects that may be affected by magnets, including credit cards, medical devices, etc. If you are using medical devices, including a pacemaker, defibrillator, etc., please consult with your doctor.
- Do not hit or damage the product or its batteries.
- Be cautious that any other matters, including metallic objects, liquid, or dirt do not come into contact with charger connectors or battery connectors.
- Stop using immediately if the product has damaged its glass, acrylic part, etc. or if it emits smoke or a burning smell, and repair it at Samsung Electronics's Customer Support center.
- Do not expose the batteries while using them.
- Do not disassemble or reuse batteries.
- Be cautious that children and pets do not bite the product or put it in their mouths.
- The appropriate use temperature is between 0 and 35 °C, and the appropriate storage temperature is between -50 and -20 °C. In a higher or lower temperature than the recommended temperature, the product may be damaged, or the battery life may be decreased.
- Do not use the product in high heat or near a fire.
- Do not maintain the same screen on the entire or partial display for a long time. It may cause screen retention, burn-in, or remaining spots.

Precautions Before Using



Warning

Do not install in bathrooms or areas with high humidity.

It may cause electric shock, fire, product deformation, or malfunction.



Avoid using in areas with dust or areas prone to rust.

It may cause electric shock, fire, product deformation, or malfunction.



Safety Precautions

Precautions Before Using

Warning

Do not operate in settings with temperatures exceeding 40°C.

It may cause fire or malfunction.

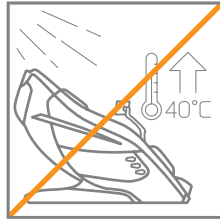

Do not install it outdoors.

It may cause safety accidents, physical damage, product damage, or malfunction.

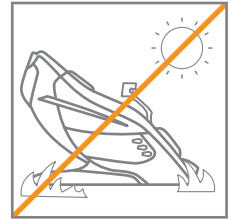

Do not use near heaters or any heat-emitting objects.

It may cause product damage, fire, or malfunction.

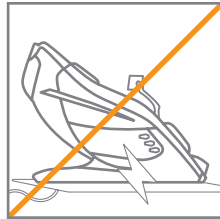

Install and use only on a flat, stable surface.

It may cause safety accidents, physical damage, product damage, or malfunction.

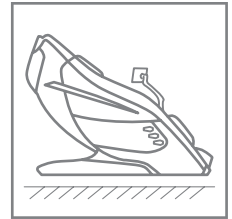

Use in areas with ample space and satisfactory air circulation.

It may cause product deformation, mold, or malfunction.

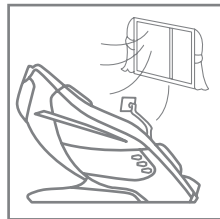

Users should not disassemble parts.

It may cause safety accidents, physical damage, product damage, or malfunction.

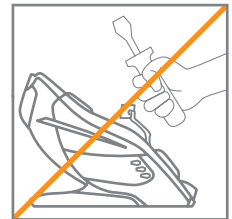

Do not use simultaneously with other electronic or medical devices.

It may cause safety accidents, physical damage, product damage, or malfunction.

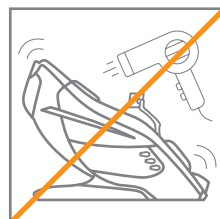

Do not spill or spray foreign substances on the product.

It may cause safety accidents, physical damage, product damage, or malfunction.

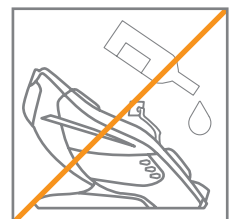

Do not place heavy objects on this product.

It may cause safety accidents, physical damage, product damage, or malfunction.

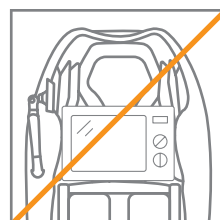

Please take precautionary measures to ensure toddlers, pets, etc., do not crawl under or onto the back of the chair, leg rest, etc.

It may cause safety accidents, physical damage, product damage, or malfunction.

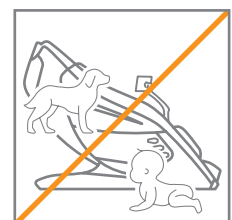

Safety Precautions

Precautions Before Using

Caution

Do not install or repair without the assistance of technicians.

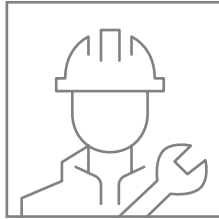

It may cause safety accidents, physical damage, product damage, or malfunction.

Do not use the product for purposes other than what is stated in this Manual.



It may cause safety accidents, physical damage, product damage, or malfunction.

Do not move the product by its power cable or pull the cable with your hand.

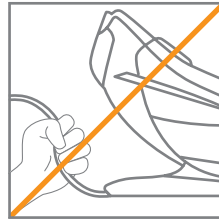

It may cause electric shock, fire, or malfunction.

Only connect the product to outlets with protective grounding.

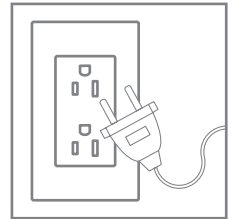

It may cause electric shock or injury.

Check if the product is connected to power before use.

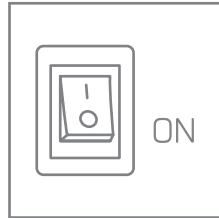

This allows for appropriate use of the product.

Plug device into a 220V~ power outlet only.

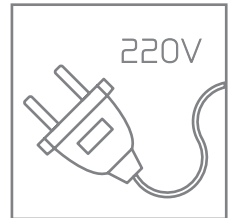

It may cause electric shock or malfunction.

Do not install in settings where it is difficult to unplug.

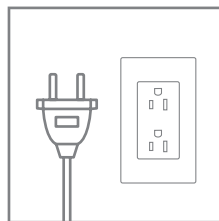

It may cause safety accidents, physical damage, product damage, or malfunction.

When unplugging the power plug, make sure to hold the power plug itself instead of pulling the cable.

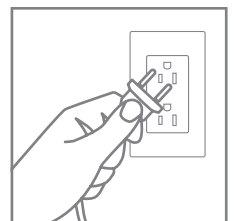

It may cause electric shock, fire, or malfunction.

Use the massage chair after checking safety sensors and if any children or pets are around.

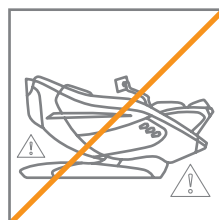

It may cause safety accidents, physical damage, product damage, or malfunction.

Please note that the sheets may become discolored from dark-colored clothes, including jeans.

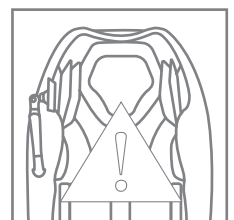

It may cause sheet discoloration.

Safety Precautions

Precautions for Use

Warning

Check how to use the product and its possible side effects.

This allows for appropriate use of the product.

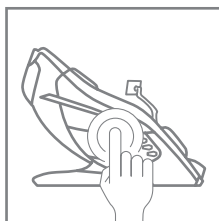

Do not connect or disconnect the power plug with wet hands. It may cause electric shock.

It may cause electric shock, fire, or malfunction.

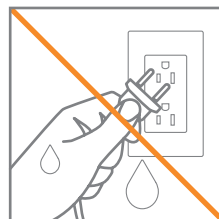

Do not use the chair if your body is wet.

It may cause electric shock, fire, or malfunction.



Do not use the massage chair directly after a heavy meal.

It may cause physical damage.

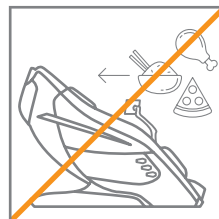

Be careful not to let any body parts get caught during use.

It may cause safety accidents, physical damage, product damage, or malfunction.



Be careful not to focus on a certain body part for too long as it may become excessive.

It may cause safety accidents, physical damage, product damage, or malfunction.

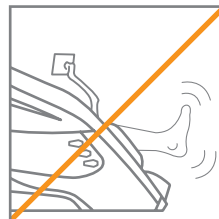

Disconnect the power plug from the socket when the massage chair is not in use.

It may cause electric shock or malfunction.

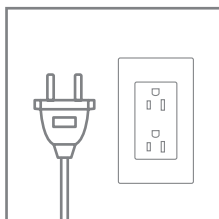

Toddlers and babies should not use the massage chair.

It may cause safety accidents, physical damage, product damage, or malfunction.

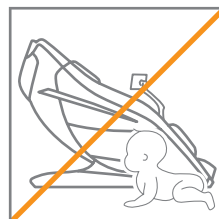

Do not place your head, elbows, chest, abdomen or knees on the massage chair and attempt to use it.

It may cause safety accidents, physical damage, product damage, or malfunction.

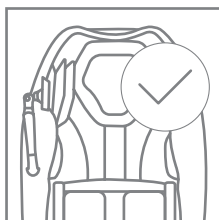

Control the massage balls to ensure they are being operated in the right position.

It may cause safety accidents, physical damage, product damage, or malfunction.

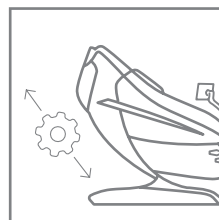

Safety Precautions

Precautions for Use

Warning

Wait until the reclining unit returns to its original position to get off the chair.

It may cause safety accidents, physical damage, product damage, or malfunction.

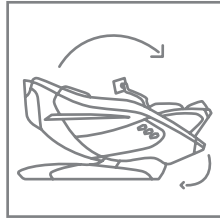

Stop using the massage chair immediately if you experience any pain or discomfort and take appropriate measures for your health.

It may cause physical damage.



Consecutive uses may burden your body. Select whether to keep using it according to your health condition.

It may cause physical damage.

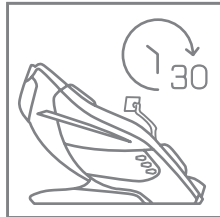

Prevent children or pets from playing around the massage chair during the operation.

It may cause safety accidents, physical damage, product damage, or malfunction.

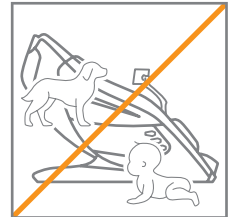

Do not operate the massage chair where aerosol (spray) products are being used or oxygen is being administered.

It may cause product damage, fire, explosion or malfunction.

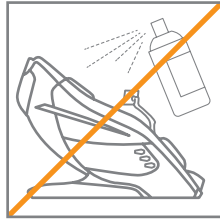

Do not operate the massage chair when wearing accessories.

It may cause safety accidents, physical damage, product damage, or malfunction.

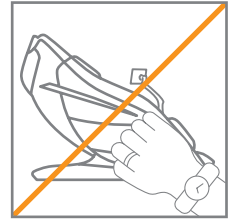

Ensure that long hair does not become entangled in the massage chair.

It may cause safety accidents and physical damage.

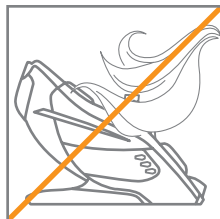

Do not drop or insert any objects in the empty spaces.

It may cause safety accidents, physical damage, product damage, or malfunction.



If the cable or plug malfunctions, is damaged, or is soaked in water, do not operate the massage chair. Contact the Customer Service Center for inspection and repair.

It may cause electric shock, fire, or malfunction.

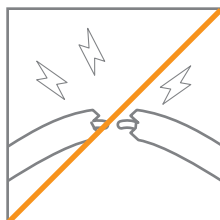

Be aware not to burn when using the heating feature.

It may cause a low-temperature burn.



Safety Precautions

Precautions for Use

Warning

Sit in an appropriate position in the massage chair.

It may cause safety accidents, physical damage, product damage, or malfunction.

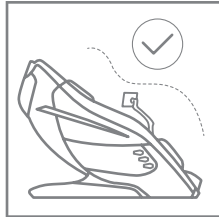

Do not use the massage chair when the cover is torn or removed.

It may cause safety accidents, physical damage, product damage, or malfunction.

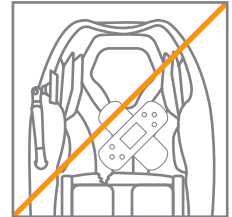

Caution

Do not let more than two people operate the massage chair at the same time.

It may cause safety accidents, physical damage, product damage, or malfunction.

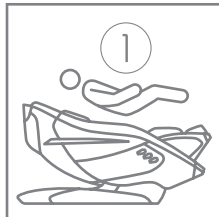

Avoid using the massage chair where the ambient temperature rapidly changes.

It may cause physical damage or injury.

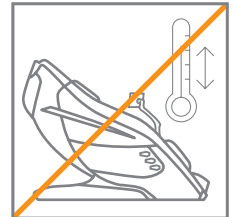

Do not apply more than 120kg of pressure on the product.

It may cause safety accidents, deformation, noises, product damage, or malfunction.



People shorter than 150cm or taller than 190cm may feel different when massaging.

It may cause a lack of tightness between massage product damage, or malfunction.



Do not stand on the massage chair. Please use it in sitting position.

It may cause safety accidents, physical damage, product damage, or malfunction.



Be careful of catching hypothermia when falling asleep after a massage.

It may cause safety accidents, physical damage, etc.



Safety Precautions

Precautions for Use

Caution

Make sure the cable is not damaged or excessively bent.

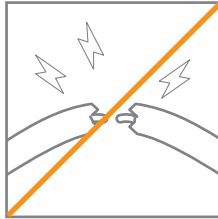

It may cause electric shock, fire, or malfunction.

Please start at a lower intensity for safe use.

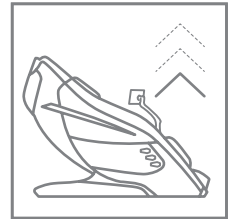

It may cause physical damage.

Do not hold the leg massage unit with your hands.

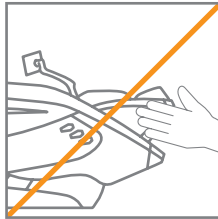

It may cause safety accidents, physical damage, product damage, or malfunction.

Do not lean or hang on the back side of the massage chair.

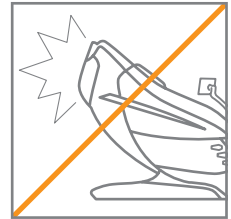

It may cause safety accidents, physical damage, product damage, or malfunction.

Prevent pets from biting the power cable.

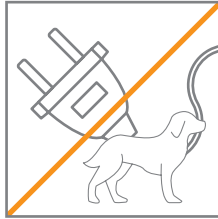

It may cause electric shock, product damage, or malfunction.

Do not stand on the leg rest when the massage chair is reclining.

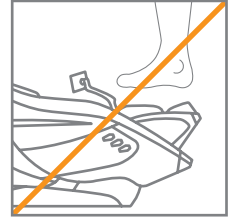

It may cause safety accidents, physical damage, product damage, or malfunction.

Please ensure the power switch is off before connecting the power.

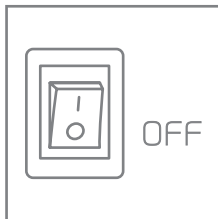

It may cause electric shock, product damage, or malfunction.

Do not sit on the back of the massage chair, arm massage unit, or leg massage unit.

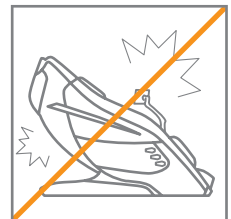

It may cause safety accidents, physical damage, product damage, or malfunction.

Do not use the Bluetooth speaker at a loud volume for a long period of time. (*Applies to some massage chairs)

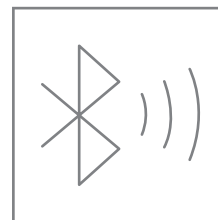

It may damage your hearing ability.

Do not stand up while holding the tablet holder with your hands. (*Applies to some massage chairs)

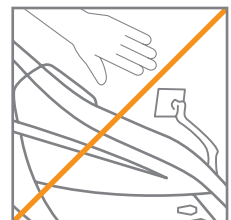

It may cause safety accidents, physical damage, product damage, or malfunction.

Safety Precautions

Precautions for Use

Caution

Do not wash the product with water.

It may cause electric shock, fire, or malfunction.

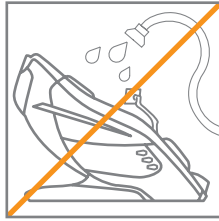

Please disconnect the power plug before cleaning or mending the massage chair.

It may cause safety accidents, physical damage, product damage, or malfunction.



Gently remove dirt with a soft cloth and do not use organic solvents, such as thinner, or chemicals.

It may cause product damage.

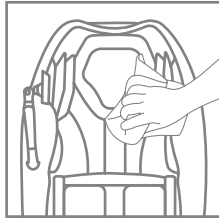

Use the dedicated leather cleaner when cleaning the natural leather sheets. (*Applies to some massage chairs)

It may cause product damage.

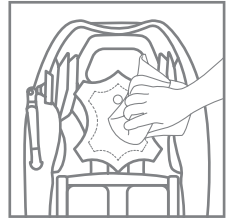

Use a sealed cable when charging via the USB charging port. (*Applies to some massage chairs)

It may cause electric shock, fire, or malfunction.

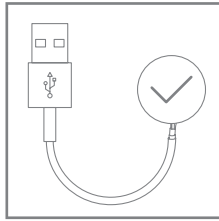

※ Sealed cable refers to a cable with a protected cord covered with aluminum foil, copper, or steel nets to reduce noise from the outside and inside.

Safety Precautions

Precautions for Use

Precautions

- **Do not use the product if**
 - Doctor diagnoses to not use this massage chair for those who suffer from thrombosis, embolism, a serious varicose veins
 - Pregnant women in the first trimester or the beginning of the third trimester
 - Those who suffer from severe diseases related to the heart, kidneys, or liver
 - Those who suffer from schizophrenia or other mental disorders
 - Those who suffer from uncontrollable epilepsy or other brain diseases
 - Those who cannot move by themselves
- **Before use, consult with a doctor if**
 - Pregnant women other than those who are within the first trimester and may experience side effects from the use
 - Those who have higher body temperature and suffer from acute inflammation, including chills and fever
 - Those who suffer from severe skin disease, including pressure sore or burn
 - Those who suffer from a malignant tumor
 - Those who are old, suffer from extreme weight loss or loss of muscle tissue due to other diseases
 - Those who need to stay in bed due to medical treatment
 - Those who are diagnosed with acute disc and acute cervical sprain
 - Those who suffer from severe osteoporosis
 - Those who are using implantable electronic medical devices, including implantable pacemaker
 - Those who lack communication ability
 - Those who have difficulty moving their body
 - Those who have any other health concerns
 - Those with joint discomfort due to hip or knee joint surgeries (artificial joint, fracture, etc.)

Instructions for Use Heating Feature

- If using the product long without rest, it may cause a low-temperature burn or any other risks.
- Do not let skin come in direct contact with parts of the massage chair that heat up.
- Supervise young children, seniors, and patients when they are using this product as they have sensitive skin.
- Do not fall asleep with the heating function on.

Possible Side Effects

- **Please note the following side effects, which may occur during use.**
 - Minor abrasions, bruising, etc.
 - Damage to muscle or tendon injury due to overuse or too much pressure
 - Allergic reactions and burns
 - Elderly spine fractures, dislocated joints, etc.

Safety Precautions

Precautions for Measuring Body Composition

※ The Korean Ministry of Food and Drug Safety classifies the body composition test as a common health care (wellness) test for maintaining or improving one's body. This product is not a medical device.

Warning

- **Do not use the machine when you wear the following medical electrical devices: The massage chair may cause malfunctions to these medical electrical devices and there is a likelihood of serious life-threatening injury.**
 - Implanted medical electrical devices, such as a pacemaker.
 - Life-sustaining medical electrical devices, such as artificial lungs and heart.
 - Handheld medical electrical devices, such as electrocardiographs.
 - Consult with your primary care physician or specialist if pregnant women intend to use the product.
 - The product is not a medical device. Therefore, users cannot diagnose diseases with the product and should visit a doctor's office for diagnosis.
 - If a user is losing weight, exercising, or following a specific diet, do not diagnose yourself and follow the instructions from doctors or specialists.
-

Caution

- Do not install the product within 1 m from medical or other treatment devices using short waves or microwaves.
 - Do not connect with high-frequency instruments.
 - Pay special attention that the person's body is in contact with other conductors, such as other people or metals, during measurement.
 - Do not attach the sensors to objects other than the human body for measurement.
 - People with contagious or infectious diseases should not touch or use the product.
 - Wash the product with a soft cloth after use.
 - Pay special attention not to get garbage or liquids, such as beverages, on the product.
-

Precautions for Wireless Charging

※ Wireless charging is limited to products equipped with a charging pad.

- **Place the middle of a mobile device with wireless charging on the charging pad, which is placed on the right arm massage unit. An inappropriately located device may result in slow charging or failure to charge.**
 - Using covers made of thick materials on the mobile device may prohibit normal charging. Therefore, remove it from the device and charge it.
 - Charge efficiency and speed may vary depending on the product's status, ambient temperature, and environment.
 - Wireless charging is not available when connecting your mobile device to charger cables during wireless charging.
- **Do not place your credit card, fare card, door lock card, etc., between the mobile device and its cover.**
 - Products that use magnetism may lose their data due to the massage chair's magnetism.
- **Do not place metals on the product while charging, including coins, keys, or necklaces.**
 - It may cause product deformation or a malfunction.
 - It may cause a fire if metals come into contact with the battery charger.
- **Stop using applications or the product for a few minutes if the product gets extremely hot.**
 - Extended contact with the heated product may cause low-temperature burns, including red rashes, discoloration of the pigment, etc.

Components and Descriptions

Opening the box

This product is packaged in four boxes. Please check that you have received all the necessary parts.

- **Main Body Box:** Body, Back/Buttocks Sheet, Head Sheet, Accessory Box (Power Cable, Tablet Holder, and User Manual)
- **Arm Massage Unit**
- **Leg Massage Unit**
- **Tablet Box:** Tablet Controller

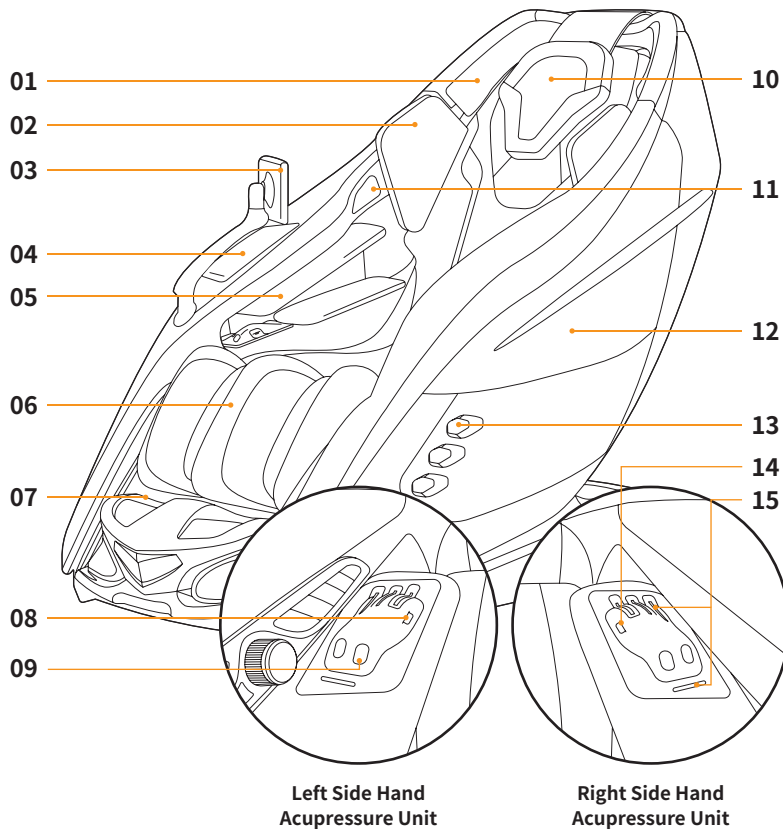

Exterior

- 01 Rear Speaker
- 02 Shoulder Massage Unit
- 03 Tablet Controller
- 04 Tray / Wireless charging pad
 - ※ Wireless charging is limited to products equipped with a charging pad.
- 05 Arm Massage Unit
- 06 Leg Massage Unit
- 07 Foot Composition Measuring Connector
- 08 Left Side Hand Acupressure Unit Button
 - ※ Adjust the zero gravity level from 1 to 3
 - ※ Press and hold it for more than 3 seconds to return to its original position
 - ※ Press the hand acupressure button or inside key during zero gravity to halt the zero gravity angle adjustment
- 09 Hand Composition Measuring Connector
- 10 Head Sheet
- 11 Front Speaker
- 12 Side Panel
- 13 LED Lights
- 14 Right Side Hand Acupressure Unit Button
 - ※ Start/Pause Massage
 - ※ Press and hold it for more than 3 seconds to turn the power ON/OFF
- 15 Hands Acupressure Unit LED

Components and Descriptions

Opening the box

This product is packaged in four boxes. Please check that you have received all the necessary parts.

- **Main Body Box:** Body, Back/Buttocks Sheet, Head Sheet, Accessory Box (Power Cable, Tablet Holder, and User Manual)
- **Arm Massage Unit**
- **Leg Massage Unit**
- **Tablet Box:** Tablet Controller

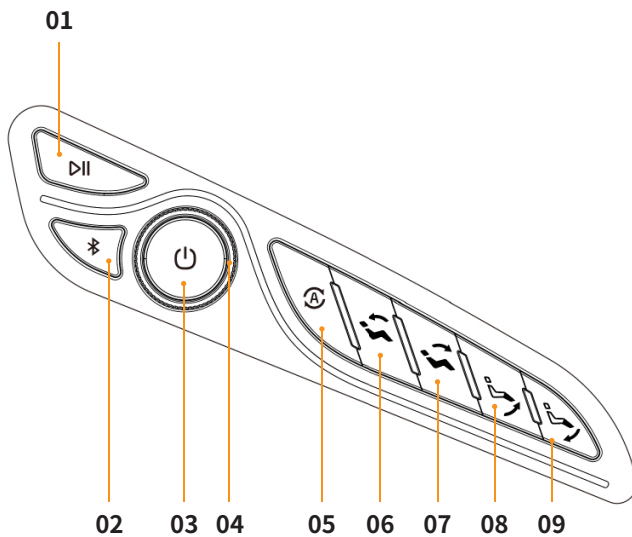

Inside Key

- 01** Massage Start/Pause
 - 02** Bluetooth ON/OFF
※ If the product is connected to any mobile devices
 - 03** Power ON/OFF
 - 04** Volume Adjust (Dial)
 - 05** Auto Mode
※ Neck/Shoulder > Back/Spine > Legs-Hip Stretch
 - 06** Reclining Angle Flat
 - 07** Reclining Angle Upright
 - 08** Raise Leg Unit
 - 09** Lower Leg Unit
-

How to Connect the Product | Moving and Installation

Connecting to power source

Connect the power cable to its port positioned on the bottom and back region of the main body. Turn on the massage chair and tablet controller.

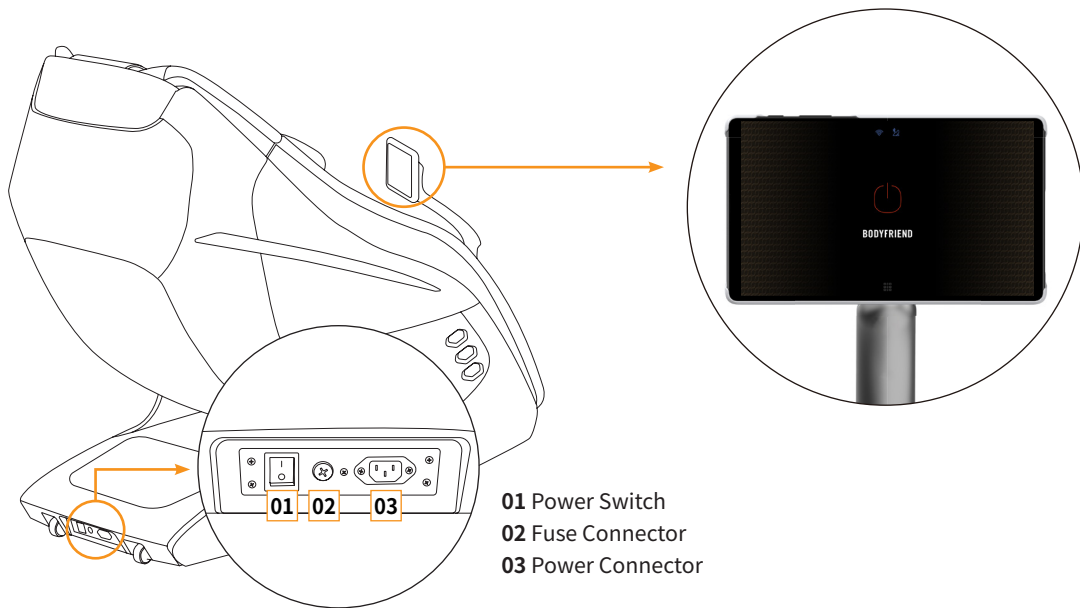

Check installation space

- Before installation, check whether there is enough room for installation.
- Remove all obstructions or miscellaneous objects around the product.
- Do not install the product with its back facing a glass window.
- Recline the product until it is convenient enough to move, then move it to the desired location. Install it by slowly putting it down.
- Be careful that the cables do not become stuck under the product during installation.

- ※ The weight of the product may cause damage or discoloration to the floor.
- ※ When moving the product, make sure more than two people carry it together.

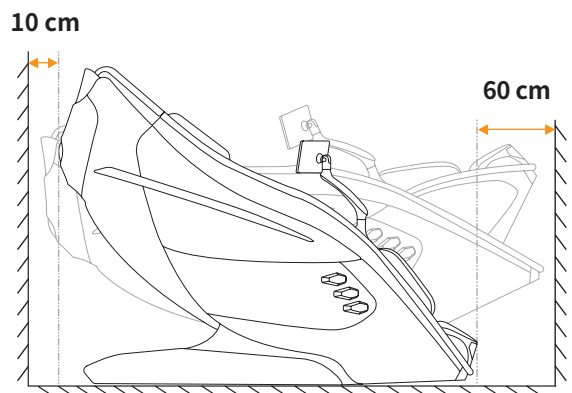

Tablet Controller Operation and Program Description

Start

- 01 Use the tablet controller via Bluetooth connection to the massage chair.
- 02 Bluetooth is automatically connected when the massage chair and tablet are powered on.
(If auto-connect fails, please refer to [How to Connect Manually] below.)
- 03 Connect the Bluetooth and register your account according to the instructions.

※ Using the product with a guest account may limit some services.

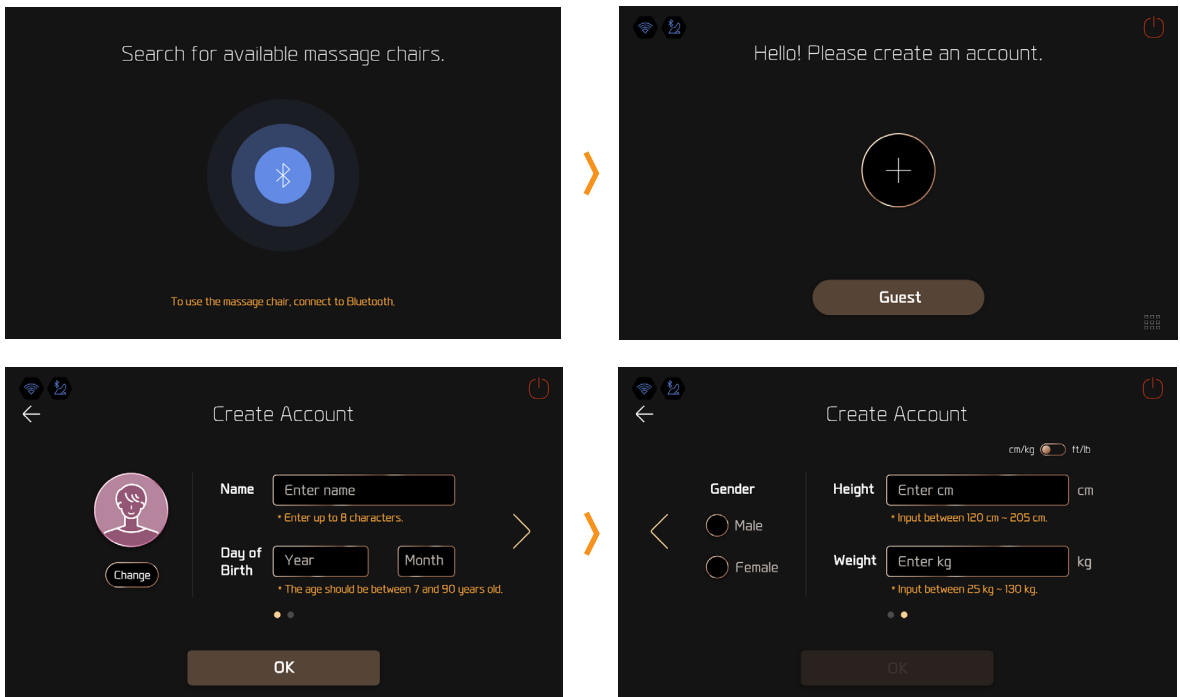

[How to Connect Manually]

- 01 If Bluetooth auto-connect fails, please manually connect the massage chair to Bluetooth according to the instructions below.
- 02 Press the Bluetooth icon at the top of the screen and select the desired Davinci massage chair on the list.

※ If users can't find the massage chair you want to connect on the list, please check whether the power is on or restart the machine.

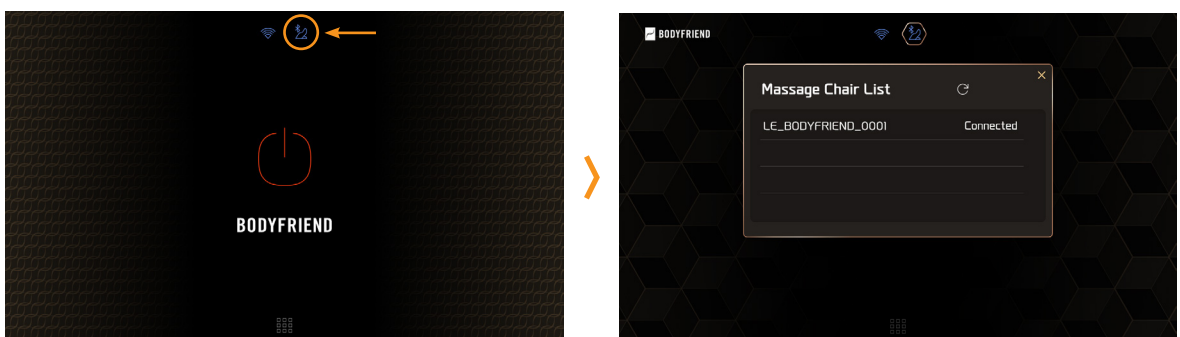

Tablet Controller Operation and Program Description

Home Screen Components

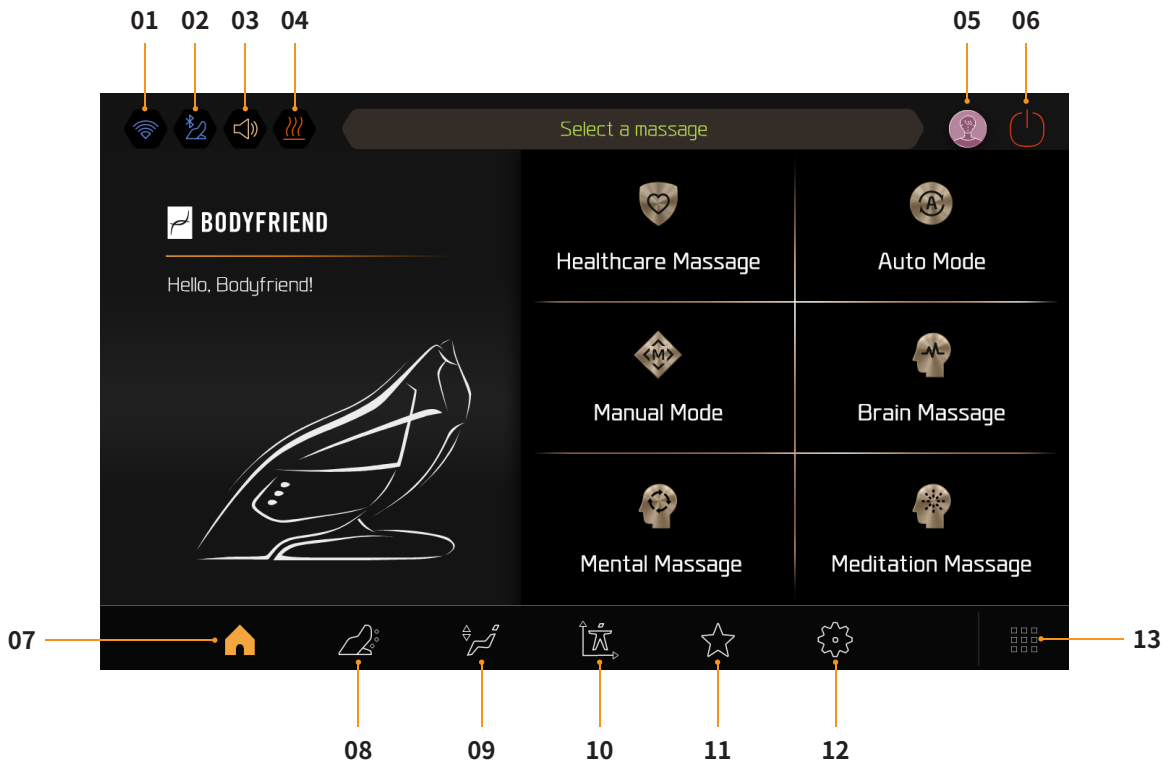

01 Wi-Fi Device List: Display available Wi-Fi device list.

02 Bluetooth List: Display available Massage Chair Bluetooth list.

03 Volume Adjustment: Adjust the volume levels of the massage chair.

04 Heating Settings: Heating for 30 minutes, set up heating features on [heating balls, waist, palm, calf/Feet].

05 User Account: Go to the User Account screen.

06 Power: Turn the massage chair on or off.

07 Home: Go to the Home screen.

08 Message Status Screen: Go to the currently playing Massage mode.

09 Massage Chair Controls Screen: Manually adjust the reclining angle and leg unit angles and length.

10 Body Composition Massage: Quick link to the Body Composition Massage programs.

11 Favorites: Go to the Favorites list.

12 Settings: Go to the Settings screen.

13 Apps (App drawer): Users can run all apps, including the existing apps on the tablet controller and the new apps the user downloads.

Users can enjoy playing games, watching videos, and listening to music just like they are using a tablet during the massage.

Tablet Controller Operation and Program Description

Massage Screen Components

※ Some components may vary while playing the Auto Program.



01 Current Massage Mode Indicator: Display the currently playing massage mode.

02 Massage Time: Display the remaining massage time. Users can choose their desired massage time from a pop-up message.

※ Users can't adjust the massage time for some auto programs with the fixed massage time.

03 Pause Massage: Pause the currently playing massage.

04 Stop Massage: Stop the currently playing massage.

05 Roller Speed: Adjust the roller speed levels for the calves/soles unit.

06 Massage Speed: Move the button up and down to adjust the massage speed.

07 Massage Technique: Choose desired massage techniques.

08 Massage Width: Adjust the massage ball width on the back unit.

09 Massage Technique: Choose the desired massage techniques.

10 LED Therapy: Turn the LED therapy On/Off.

11 Airbag Intensity: Adjust the airbag locations and intensity levels.

12 XD Intensity: Move the button up and down to customize the range for the roller heads to protrude along the contours of the user's body.

13 Massage Position: Use the Up and Down arrows to adjust the massage position.

14 Automatically Return to Original Position: The massage chair returns to its original position automatically upon completion of the massage. When OFF is pressed, the product returns to and maintains its original angles after the massage.

Tablet Controller Operation and Program Description

Healthcare Massage

Home > Healthcare Massage > Select desired massage mode > Automatically check for the contour of the user's body > Adjust the shoulder unit location in detail > Massage starts

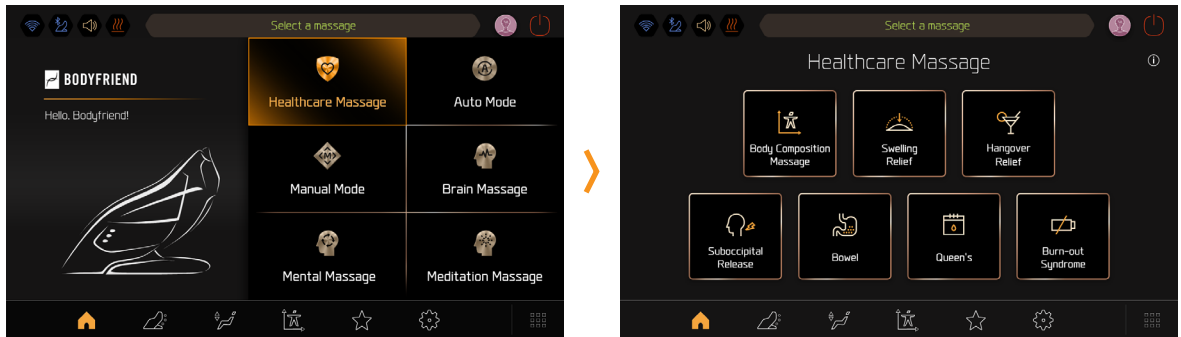

Body Composition Massage	This course recommends a customized massage by measuring and analyzing your body contours.
Swelling Relief	Helps blood circulation and reduces swelling by using full-body airbags.
Hangover Relief	Massages the key acupuncture points for a hangover cure.
Suboccipital Release	Relaxes and focuses on four muscles attached to the occipital bone and back of the neck.
Bowel	A course that massages the buttocks and major stimulation points beneficial for the bowel.
Queen's	A course specialized for women that massages the hip and buttocks area.
Burn-Out Syndrome	A course that provides a relaxing massage with soothing music to relieve exhaustion from stress.

Tablet Controller Operation and Program Description

Body Composition Massage - How to Measure Body Composition

01 Select [Body Composition Massage icon] at the bottom of the Home screen. Or Select Home > Healthcare Massage > Body Composition Massage.

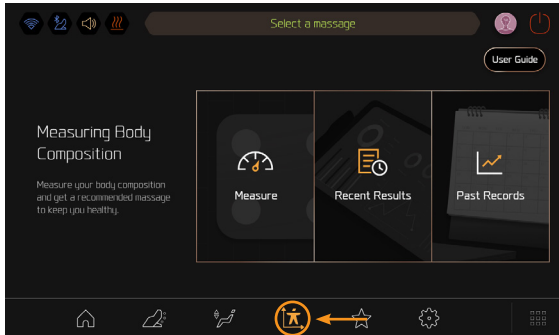

02 Select [Measure] and input the required information for measurement following the instructions and press [Start Measure].

※ Before measuring, please read the [User Guide] in the upper-right corner and use this feature properly.



[Correct Measurement Posture]

- Firmly place both soles of the feet on the foot electrodes of the footrest. Please note that the bare feet must directly touch the electrodes.

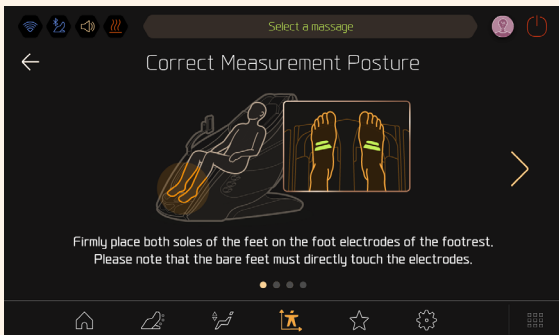

- Place both of your hands on the hand electrodes and keep your palms in close contact with the two electrode surfaces evenly.

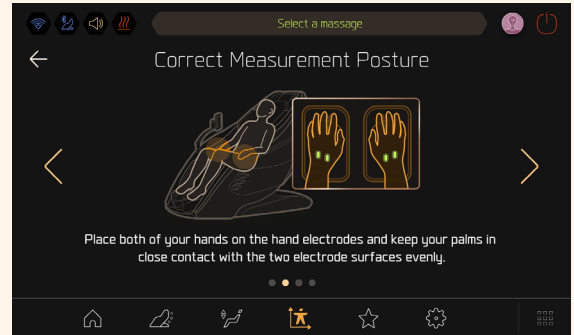

- Make sure there is space between the armpits.



- Make sure both your knees stay apart from each other.

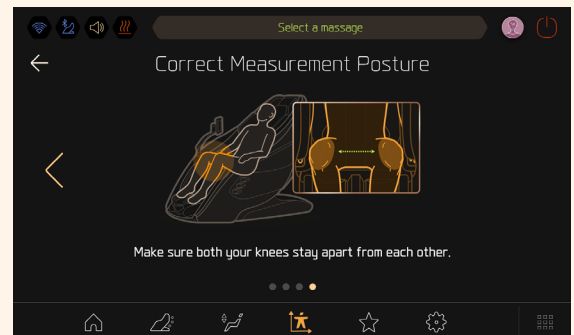

Tablet Controller Operation and Program Description

Body Composition Message - How to Measure Body Composition

03 Read the Precautions for Measuring Body Composition.

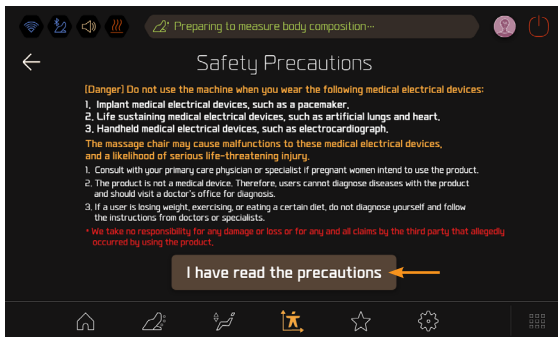

04 Measure the body composition for 40 seconds. Relax your body during measurement and maintain the measurement posture.

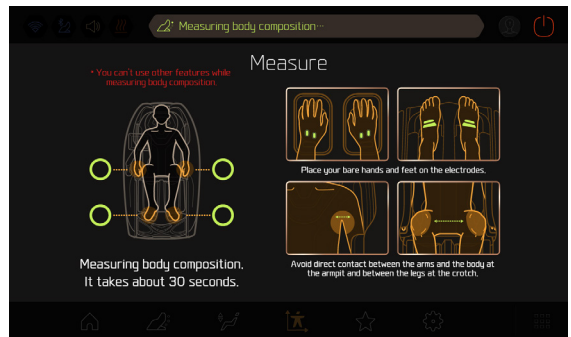

05 Upon completion of body composition measurement, the product recommends customized massages for your contour based on the analysis.

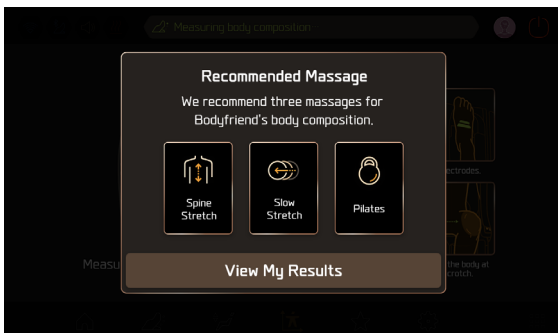

06 For detailed analysis, go to [Recent Results].
* Skeletal Muscle/Obesity Analysis, Nutritional Status Analysis, Overall Comment



07 Users can check the changes in weight, muscle mass, and body fat percentage over the last week/month/year via [Past Records].



Tablet Controller Operation and Program Description

Body Composition Massage - When Measurement Fails

- Check that the values entered in User Account are correct.
- Try again with the correct measurement method and comfortable clothes.
- Measurement may fail if the individual's palms have scrapes from eczema or too much dead skin.
- Measurement may fail if the individual's hands or feet are dry.
- Measurement may fail if an individual wears a tight top or many accessories, including a watch on the wrist.
- Measurement may fail if the individual has a body fat percentage that is too low with too much muscle mass or vice versa.
- If your body is too thin, it cannot be measured outside the effective range of measurement.
- Measure with bare hands and feet. Correct measurement may fail if an individual wears socks or stockings as this may disrupt the current's flow.

※ Result differences due to different measurement times, including after meals and after exercise, are not because of mechanical error. If you have any questions about the measurement results, contact your representative.

Body Composition Measurements - Measurement Results Guide

Weight	It contains all body composition weights and represents the body weight in pounds (lbs)
Muscle Mass	It indicates the muscle mass in the body. An increase in muscle reduces body fat and increases energy consumption, helping weight loss.
Body Fat Percentage	It represents the percentage of body fat in the body. Recently, obesity has been defined by whether one's body fat exceeds a given level. If one has too much body fat, they have a risk of diabetes, high blood pressure, etc.
BMI	BMI is one's weight in kilograms divided by the square of a height in meters. It indicates the obesity level.
Body Hydration	It represents the percentage of water in the body rather than one's weight. The body water percentage changes as we age, and may vary depending on each individual.
Protein	It is a key component in forming all cells and tissues of the body. A lack of protein results in weakened hair, skin, and immune system and may cause fatigue and skin breakouts.
Minerals	They are inorganic components in bones and bodily fluids that form bones and teeth. Minerals are essential nutrients for life support.
Body Fat	It means the percentage of fat from the weight. An ideal body fat percentage for adult males is 15-18% and for adult females is 20-25%.

※ The results may vary depending on the measurement equipment.

Tablet Controller Operation and Program Description

Auto mode

Home > Auto Mode > Select desired massage mode > Automatically check for the contour of the user's body > Adjust the shoulder unit location in detail > Massage starts

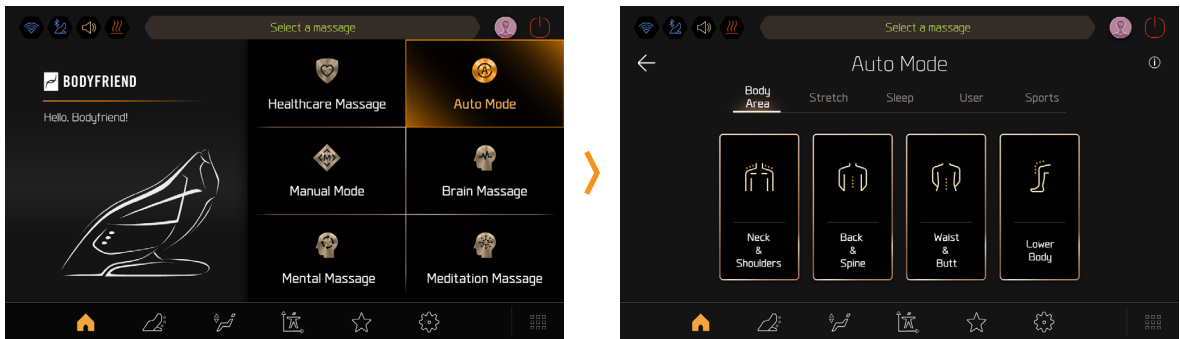

Body Area	Neck/Shoulders	Relaxes neck and shoulders via kneading and stretches.
	Back/Spine	Relaxes back and spine via acupressure and rubdown kneading.
	Waist/Butt	Relaxes waist and buttocks areas via acupressure and rubdown kneading.
	Lower Body	Provides various massages focused on the waist and leg areas.
Stretch	Legs-Hip Stretch	Strongly stretches the lower body by supporting the pelvis and pulling the legs.
	Spine Stretch	Strongly stretches the spine by supporting the back of the head and pulling the legs with spine area massage.
	Slow Stretch	Provides soft stretching and relaxation for those who want to avoid strong stretching.
Sleep	Airbag Stretch	Relaxes and provides soft massage with airbags.
	Natural Sleep	Induces sleep via soft and simple full-body massage and angle variation for 30 minutes.
	Nap	Induces an effective nap of less than 20 minutes by repeating soft tapping.
	Hammock Nap	Provides comfortable massage like sleeping in the hammock via swing patterns.
User	Soft Sound	Provides a full-body rubdown kneading course without airbags and is ideal for use at night when everyone is sensitive to noise.
	CEO	Focuses on neck and shoulders to reduce CEO's fatigue burdened by excessive stress.
	Senior	Provides safe massage for seniors who prefer soft and mild massage.
	New Parent	Focused on the neck and waist that are fatigued by parenting and applies special airbag patterns massage on arms, legs, and pelvic areas.
Sports	Office	Provides refreshing massage on the waist, neck, and shoulders to those who sit in a chair all day long.
	Golf	Provides strong massage on arms, legs, and soles fatigued after golf.
	Pilates	Helps keep the right posture to stimulate core muscles on the buttocks and lower belly and relax muscles by reclining the chair on a full-body and leg angle.
	Yoga	Provides a dynamic massage and stretch using yoga movements for a flexible body.
	Driving	A soft massage focused on the tired upper body after a long drive.

Tablet Controller Operation and Program Description

Manual Mode

Home > Manual Mode > Select the desired massage technique > Massage starts

※ Pressing the second icon at the bottom of the Home screen will help you with detailed settings and a quick start of the manual massage.

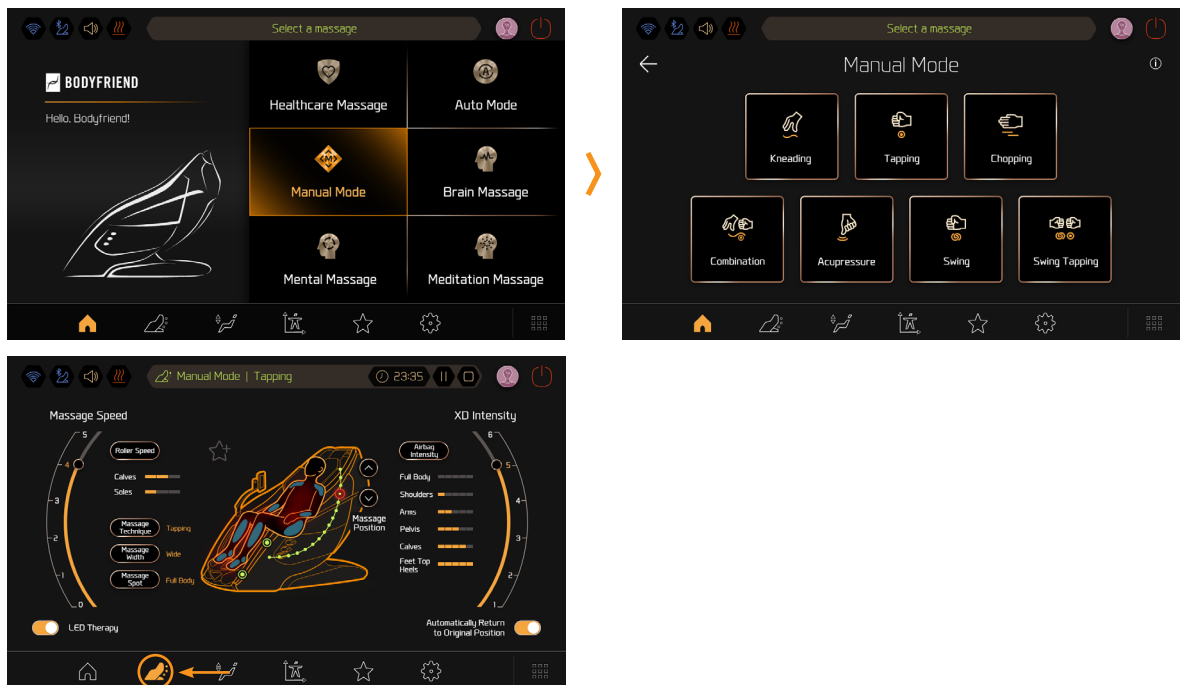

Kneading	Massage balls gather and scatter to the sides to massage. This technique is ideal for reducing severe stiffness and improving muscle cramps.
Tapping	Massage balls tap the body from the shoulders to the bottom. This technique is effective for loosening up the shoulders and back.
Chopping	Massage balls go up and down the body in a light and quick chopping motion. This technique is effective for relieving muscle fatigue.
Combination	This technique is a combination of rhythmically repeated kneading and tapping techniques to provide the advantages of both techniques.
Acupressure	Massage balls go up and down the body to deliver a deep tissue massage. This technique relieves rigid muscles in a sophisticated manner.
Swing	Massage balls repeatedly go side by side to massage the body. This technique is effective for concentrated muscle relief.
Swing Tapping	Massage balls repeatedly go side by side to tap the body. This technique is effective for concentrated muscle relief.

Tablet Controller Operation and Program Description

Brain Massage

Home > Brain Massage > Select desired massage mode > Select Music > Automatically check for the contour of the user's body > Adjust the shoulder unit location in detail > Massage starts

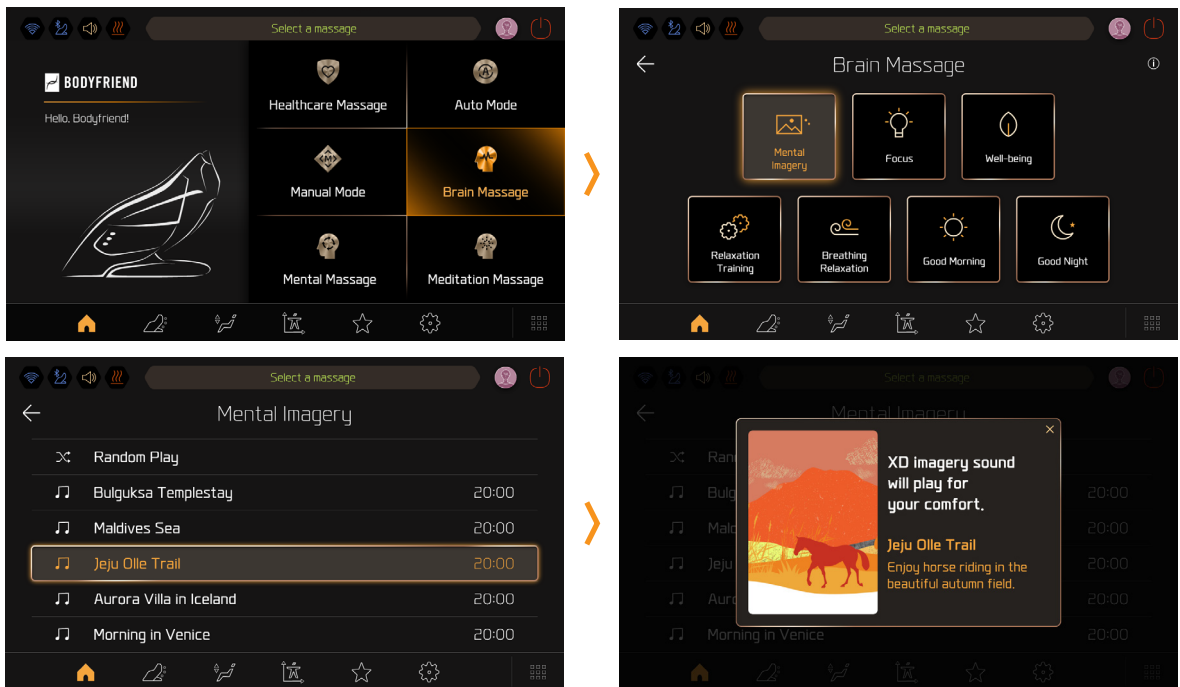

Mental Imagery

This course is for those who want to freely imagine their own getaway with XD mental imagery sound.

Focus

This course is for those who need to rest their fatigued brain due to excessive academic or work stress and recharge their mind and body.

Well-being

This course is for those who need a break due to excessive stress from their daily life.

Relaxation training

This course is developed by using gradual muscle relaxation therapy for those who want to reduce tensions and stress in their mind and body.

※ Gradual muscle relaxation therapy: Intentionally reduces the bodily tension of muscles to remove tension from the mind.

Breathing Relaxation

Developed by breathing relaxation therapy for those expecting important tests or announcements.

※ Breathing relaxation therapy: Intentionally adjusts breathing to relax the mind and reduces excessive tension and excitement

Good morning

Specializes in those who are not early birds and have difficulty pleasantly starting the day.

Good night

Specialized for those who want to reduce fatigue during the day and organize their thoughts before going to bed.

Tablet Controller Operation and Program Description

Mental Massage

Home > Mental Massage > Select desired massage mode > Automatically check for the contour of the user's body > Adjust the shoulder unit location in detail > Massage starts

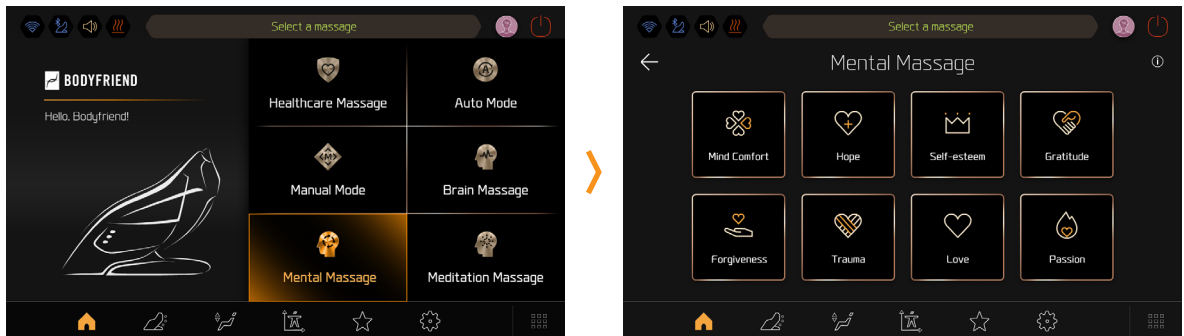

Mind Comfort	Helps those who are gloomy due to past regrets.
Hope	Helps those who suffer from anxiety and nervousness due to various concerns.
Self-esteem	Helps comfort your mind and recover self-esteem when feeling down and frustrated.
Gratitude	Helps remind us of the precious things in our daily lives and refreshes our mind.
Forgiveness	Suggests active forgiveness and comfort for yourself with calming music.
Trauma	Provides a stable mind for those who suffer from past memories.
Love	Suggests a way to love yourself via massage and breadth of mind.
Passion	Suggests to embrace the GRIT that exists in your mind during the massage.

Meditation Massage

Home > Meditation Massage > Select Level > Select Music > Automatically check for the contour of the user's body > Adjust the shoulder unit location in detail > Massage starts

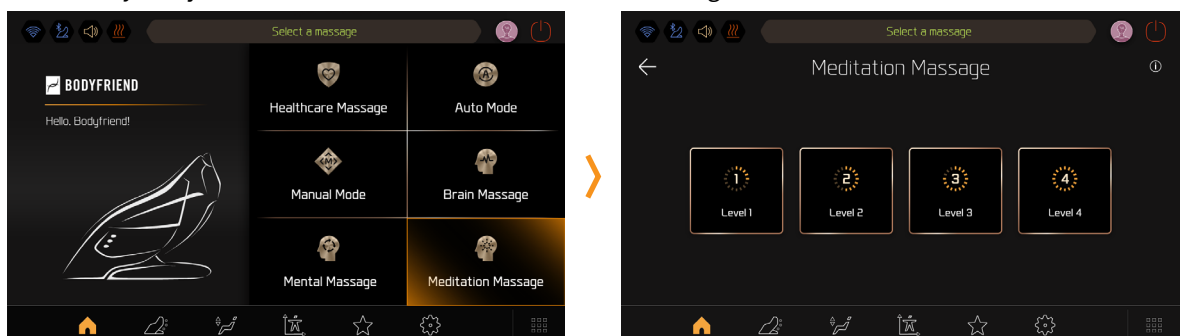

Level 1	Select from among [Awakening], [Body Scan], [Self-reflection], [Awareness], and [Breathing].
Level 2	Select from among [Effortless], [Self Love], [Self-reflection], [Awareness], and [Breathing].
Level 3	Select from among [Destress], [Sleep], [Comfort], [Self-compassion], and [Discernment].
Level 4	Select from among [Self Acceptance], [Smile], [Charity], [Calmness], and [Self-reflection].

Tablet Controller Operation and Program Description

Favorites

※ You cannot register favorites when logged in as a guest. Log in with your account and try again.

- 01 Register: Home > Select and start the desired mode > Set up customized message > Press the ☆ icon to save it in Favorites.
- 02 Start: Select the Favorites icon > Select the desired mode > Massage starts
- 03 Manage the list: Users can register up to 12 favorites. Users can change the order or remove the registered favorites on the list.

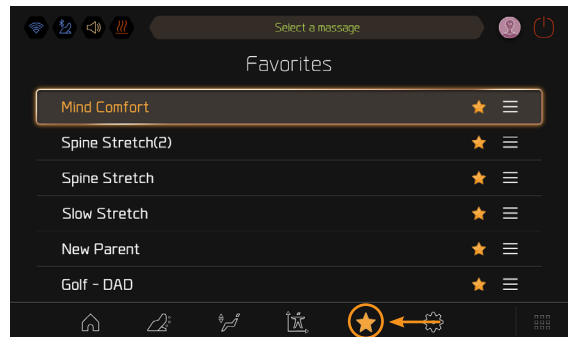

[Favorites Save History Range]

Healthcare Massage, Auto Mode, Brain Massage, Mental Massage, Meditation Massage

- 01 Message Name
- 02 Shoulder Location
- 03 Massage Speed, XD Intensity, Roller Speed, Airbag Intensity, Automatically Return to Original Position
- 04 Heating
- 05 Music Information
(for Brain, Mental and Meditation massages)

Manual Mode

- 01 Massage Technique Name
- 02 Massage Technique
- 03 Shoulder Location
- 04 Massage Speed, XD Intensity, Roller Speed, Airbag Intensity, Automatically Return to Original Position
- 05 Reclining and Leg Unit Angle
- 06 Heating

Settings

Home > Select the Settings icon

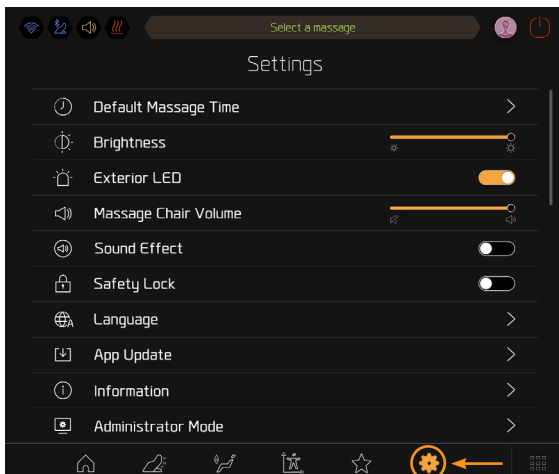

Tablet Controller Operation and Program Description

Tablet Controller - Connect to Massage Chair Speaker via Bluetooth

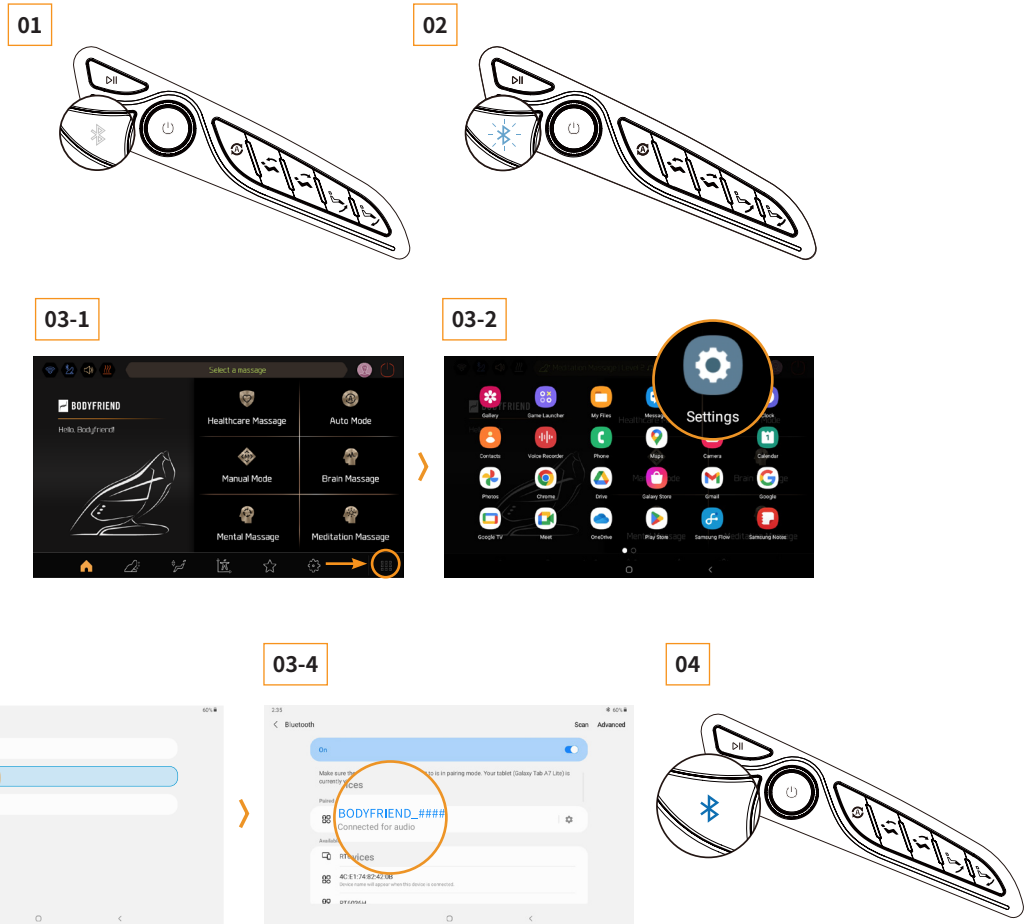

- 01** Turn on the massage chair and press the Bluetooth button of the inside key.
- 02** While connecting Bluetooth, the Bluetooth icon of the massage chair inside the key blinks in blue every second.
- 03** Tablet Home screen > Go to Apps (app drawer) screen > Settings > Bluetooth > Search > Search BODYFRIEND and connect Bluetooth.
 - ※ Name: BODYFRIEND_####
 - ※ #### is a unique Bluetooth number of the product. If there are various massage chairs in a place, please check the serial number before connecting.
- 04** The inside key's blue LED blinks with voice instructions to indicate when Bluetooth has been connected.
 - ※ If the Bluetooth connection fails or is disconnected, the white LED will turn on.
 - ※ In case of disconnection, please try again to pair the machine.
 - ※ If the Bluetooth name is not shown even if the device resets, please check if the machine is connected to other smartphones.

Tablet Controller Operation and Program Description

Mobile Device - Connect to Massage Chair Speaker via Bluetooth

01

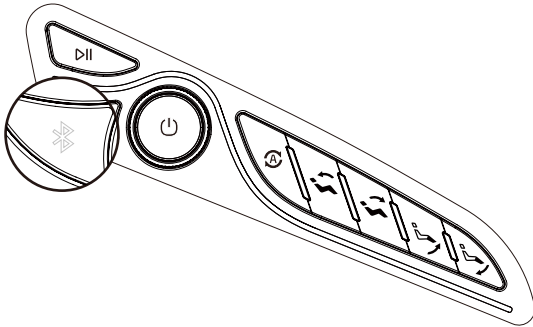

02

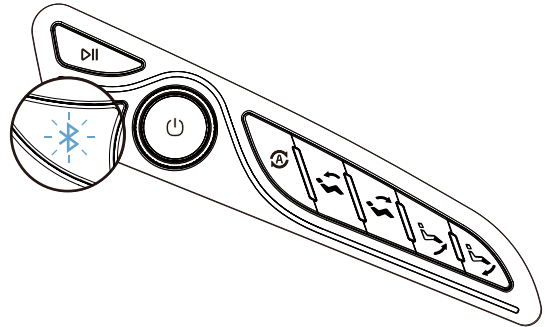

03

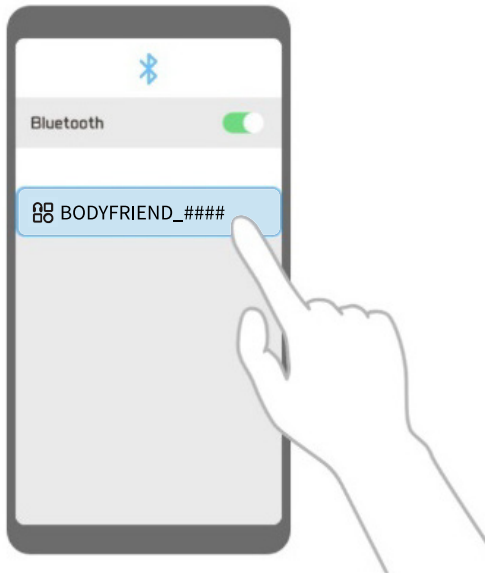

04

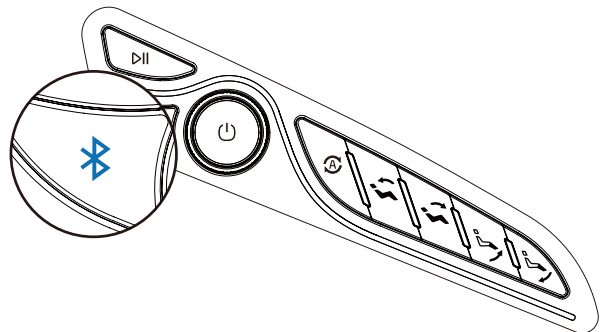

- 01** Turn on the massage chair and press the Bluetooth button of the inside key.
- 02** While connecting the Bluetooth, the Bluetooth icon of the massage chair inside the key blinks in blue every second.
- 03** Go to the Bluetooth settings on the mobile device and connect the BODYFRIEND.
 - ※ Name: BODYFRIEND_####
 - ※ #### is a unique Bluetooth number of the product. If there are various massage chairs in a place, please check the serial number before connecting.
- 04** The blue LED of the inside key blinks with voice instructions to indicate when Bluetooth has been connected.
 - ※ If the Bluetooth connection fails or is disconnected, the white LED will turn on.
 - ※ In case of disconnection, please try again to pair the machine.
 - ※ If the Bluetooth name is not shown even if the device resets, please check if the machine is connected to other smartphones.

XD PRO Module Description

BODYFRIEND's exclusive new XD massage system

1. Wide and Deep XD Massage

- Provides a rubdown massage for a wider area using the long axis of rotation of the XD module.
- Massage balls provide a sophisticated and deep massage while drawing an X pattern.

2. Ergonomic XD Massage Angle

- Adjust the angle depending on the massage technique for a more focused massage on body parts.
- Provide strong massage for big muscles and gentle massage for small muscles.
- Realize similar angles of massage conducted by a real massage therapist.

XD PRO

Customized Massage System by Analyzing User's Body Contour

1. Quick and Accurate Body Contour Recognition

- Massage modules drop along the contour of the body to recognize the accurate location of shoulders by sensing curves and pressures of the human body.
- Even during the massage mode, you can adjust the shoulder position in real time.

2. Sophisticated and Gentle Massage

- High performance sensors provide more sophisticated massage than the previous XD module.
- Precise body contour recognition enables various massage techniques.



Brain Massage Program

Brain Massage

BODYFRIEND's exclusive mind and body management induce a short break for the brain via XD brain sound, including binaural beats and special massage.

※ Binaural beats:

When two sounds in different frequencies are played, the brain perceives a third sound called a binaural beat. It syncs with brain waves to help relax and other beneficial effects.

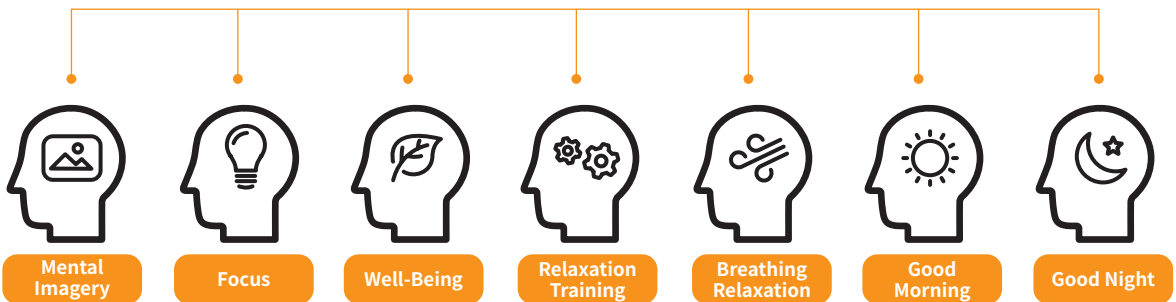

Brain Massage - Mental Imagery / Focus / Well-Being

This program is for those who want a relaxing massage with XD brain sounds, including binaural beats.

Mental Imagery	This program is for those who want to imagine their own getaway from their busy daily lives via XD brain sound and soft full-body massage patterns. We recommend this course for those who haven't experienced stress care before.
Focus	This program is for those who need to rest their tired brain due to excessive academic or work stress and recharge their minds and bodies. We recommend reducing brain and body fatigue while resting with XD brain sound and upper body massage patterns focused on the neck and shoulders.
Well-Being	This program is for those who need a break due to excessive stress from their daily lives. We recommend reducing excessive stress via XD brain sound and optimized massage patterns.

※ Brain Massage - Focus / Well-Being changes the angle automatically. You can manually change the angle after the indication of auto leg adjusts off appears.

※ Please avoid changing the song during the massage mode for the best Brain Massage.

Brain Massage Program

Brain Massage - Relaxation Training / Breathing Relaxation

This program provides voice guides to easily follow muscle and breathing relaxation for those who want an active body relaxation with a voice guide.

Relaxation Training

This program is developed by using gradual muscle relaxation therapy for those who want to reduce tension and stress with a voice guide. We recommend reducing tensions in your body by following the voice guides for muscle relaxation linked to massage.

※ Gradual muscle relaxation therapy: Intentionally reduces the bodily tension of muscles to remove the tension of mind.

Breathing Relaxation

This program is developed by breathing relaxation therapy for those expecting important tests or announcements. We recommend following the voice guides for breathing linked to massage to easily relax your extremely tense body and mind.

※ Breathing relaxation therapy: Intentionally adjusts breathing to relax the mind and reduce excessive tension and excitement

Brain Massage - Good morning / Good night

Provides positive and affirmative voice guides to start the day with optimism.

Good morning

Designed for those who are not early birds and have difficulty pleasantly starting the day. We recommend starting a day with good feelings with energetic full-body massage and voice guides to induce positive thoughts.

Good night

Specialized for those who want to reduce fatigue during the day and organize their thoughts before going to bed. We recommend wrapping up the day with good feelings by reducing fatigue with a soft, full-body massage and voice guides to remove complex thoughts.

Mental Massage Program

Mental Massage

This program calms your mind with soothing messages, gentle songs, and a rhythmic massage on the left and right region of your body.

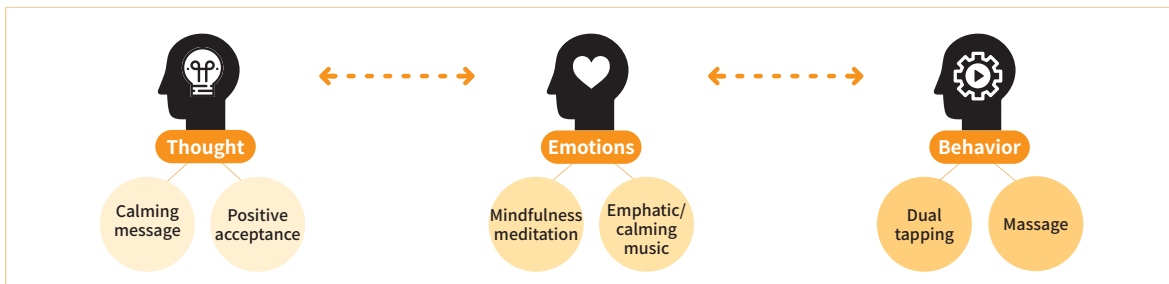

Mind Comfort	Helps those who are gloomy due to past regrets. It comforts your gloomy mind with empathic songs and messages and helps turn your emotions positive with a full-body massage by tapping the left and right sides of the body.
Hope	Helps those who suffer from anxiety and nervousness caused by vague concerns. It relaxes entire muscles that become stiff with a full-body massage by tapping the left and right sides of the body and helps effectively manage emotions with calming messages.
Self-Esteem	This helps people slow down and avoid needless self-blame when life gets out of control. Fill the void in your mind and boost confidence when feeling small and helpless.
Gratitude	This helps refresh and reflect on once-forgotten precious things and focus on themselves when angry and frustrated, or when they keep blaming circumstances.
Forgiveness	This comforts people who have suffered from their emotions for a long time and suggests active forgiveness for oneself.
Trauma	Calms people that are dwelling on past trauma, brings the mind back to the present through body stimulation and music.
Love	Relax with Bodyfriend and listen to stories from your precious people. Love your current self and create a happy future.
Passion	GRIT is not just a fierce passion at the start but the constant force always in our mind. Feel the GRIT with BODYFRIEND now. Your inner GRIT becomes clear. ※ GRIT: A psychology term highlighting effort rather than a gift. Ordinary people with average intelligence and gifts can achieve the best performance if they keep trying with passionate perseverance.

Meditation Massage Program

Meditation Massage

A course where you can experience official programs developed in collaboration with the Korean Academy of Meditation in Medicine in a massage chair.



Level 1

Awakening

Trains you to keep your thoughts in the here and now rather than the past and future.



Level 2

Mindfulness

Trains you to focus on your inner senses in the present moment.



Level 3

Managing

Trains you to manage your thoughts through the comfortable experience of massage.



Level 4

Acceptance

A new form of rest away from excessive stress through mindfulness meditation.

Awakening

Meditation massage trains you to hold your thoughts that float in the past and future in the senses and experiences of the here and now. Even the same stimulation will feel more lively and deep as you reduce your thoughts and focus on your senses through training.

Mindfulness

This training helps grow your power to concentrate on your senses in the present. You will be able to regain peace through mindfulness and by letting go of the worries that trouble you.

Managing

The stimulation of massage has the effect of bringing about positive thoughts through a pleasant and comfortable experience. Reducing your thoughts through mindfulness will sharpen your senses and allow you to get away from negative thoughts.

Acceptance

The greater the stress the more you seek stronger stimuli. The problem is that with sensory stimuli the body develops a tolerance to it making you seek new, ever stronger stimuli. Experience a new form of rest away from excessive stress and an overload of thoughts through mindfulness meditation.

Product Size and Specifications

For performance improvement, the specification may partially change without previous notice.

Model	BFB-8210EU
Rated Voltage	220-240 V~, 50/60 Hz
Power Consumption	230 W
USB	5 V / 1.5 A
Output Power	Up to 15 W
Auto Timer	5/10/15/20/25/30 minutes
Airbags	Shoulders / Arms / Pelvis / Calves / Top of Feet / Heels
Rollers	Calves / Soles
Massage Ball Range	Neck - Buttocks
Remote Controller	8.7 inch Screen Resolution: 1340 X 800 (WXGA+)
Product Weight	149 kg
User Maximum Weight	100 kg
Upright	166 (L) X 80 (l) X 125 (H) cm
Reclined	193 (L) X 80 (l) X 88,5 (H) cm
General Name	Electric Massager

Customer Support Guidelines

If you encounter minor malfunctions or errors, please refer below before contacting the customer center.

Problem	Cause	Solution
Massage chair does not operate	Did not press the Power button on the controller or inner key	Press the Power button
	Program is not selected	Select and run the program
	Power is not properly plugged in	Properly plug the power into the socket
	Power plug/cable is damaged	Please contact the after-service center
	Fuses is burnt	
	Electrical circuit is malfunctioning	
Massage chair makes noise during use	General machine noise - Air pump vibration, air inlet/outlet noises - Noise due to airbag inflation - Solenoid valves opening/closing - Sheet friction	The noise is general machine noise. There is nothing wrong with the product
	Used the massage chair for a long time	Restart the machine (after 30 min)
	Tear from long-time usage	Please contact the after-service center
Machine suddenly stops during the operation	Accidentally pressed the OFF button	Press the Power ON button
	Massage time has ended	Restart the machine (after 30 min)
Machine suddenly stops during angle change	Check the object detection sensors and whether there are any objects caught between parts	Remove the object and restart the machine
	Excessive usage or shock	Restart the machine (after 30 min)
Massage balls caught or crashed into the interior sheet during the operation	Frictions between the massage balls and sheets	Rubdown technique generates such a phenomenon due to massage balls so it's not a problem
Does not go back to the original position	Excessive use	Please contact the after-service center
Overheated controller	Use the massage chair for a long time	Restart the machine (after 30 min)
Overheated power cable	Excessive load	Restart the machine (after 30 min)
	Other miscellaneous causes	Please contact the after-service center
Airbags do not activate	Air hose disconnected	Please contact the after-service center
	Air-related power cord is disconnected	

Customer Service Descriptions related to the Tablet

This product includes a touchscreen tablet from the Samsung Electronics brand whose reference is the Galaxy Tab A7 Lite 32 GB 8.7 inches. Bodyfriend guarantees the item for a period of 2 years and the guarantee does not cover the following:

- a) the care of the product and its maintenance following normal wear and tear;
- b) any adaptation of the product which would be necessary for the purposes of compliance with the technical or safety standards applicable in a country other than that for which the product was originally designed and manufactured;
- c) damage to the product resulting from:
 - i. improper use or installation of the product (use not in accordance with the intended use of the product, installation or use not in accordance with Samsung's instructions or the technical or safety standards in force in the country where it is used, etc.)
 - ii. maintenance of the product not in accordance with Samsung's instructions or negligence in maintaining the product
 - iii. improper handling or treatment of the product (mishandling, falling, shock, contact with sand, water, or any other substance, etc.) or an inappropriate environment (poor ventilation, vibrations, exposure to humidity or excessive heat, inadequate power supply, etc.)
 - iv. use of the product with an incompatible or defective product or accessory;
 - v. an adaptation of the product for the purposes of compliance with the technical or safety standards applicable in a country other than that for which the product was originally designed and manufactured;
 - vi. a modification or repair of the product not carried out by a service provider approved by Samsung
 - vii. a case of force majeure, disaster (fire, flood, etc.), lightning, etc.
- d) for professional monitors, the calibration of screen walls, particularly following a repair

Massage Chair Customer Support Guidelines

Warranty Guidelines	Massage chair interior parts
	Mainboard, motors, air pump
	Interior electrical wiring / air hose
Fees Applied	Leather and Fabric Any fading or deterioration of leather and fabric, product parts, etc. caused by personal use.) ※The leather of this product is made of synthetic leather. In the case of synthetic leather, depending on the frequency of use and storage conditions, lifespan may vary. If damage to the leather is found, contact the place of purchase and replace it.
	Controller / Cable Wear and tear due to the frequency of use by customers, failure or damage caused by discretionary opening or dropping
	Etc. Additional charges may apply for massage chair location change or disassembling/ assembling due to customer's request.

Warranty Period

- 01 If a malfunction occurs while using the product, you can receive free service within a set period from the date of installation.
- 02 When used for shared facilities, business, or commercial use, warranty is separate/shortened.

Fees Applied

Fees apply for the following.

- 01 Problems due to liquids spilling within interior of product.
- 02 Broken or disabled parts due to excessive pressure.
- 03 Problems due to deformation or external defects caused by personal actions.
- 04 Problems due to not using parts or consumables provided by BODYFRIEND.
- 05 Malfunction due to incorrect use of operating voltage.
- 06 Problems caused by user disabling parts of the machine.
- 07 Problems caused by repairs conducted by non-BODYFRIEND technicians/employees.
- 08 Problems caused by natural disasters.
- 09 Failure to follow safety precautions listed in User Manual.
- 10 Problems caused by user's personal mistakes.
- 11 Problems caused by user's reckless behavior, inability to follow guidelines, and etc.
- 12 Problems with discoloration caused by continuous sunlight or exposure to ultraviolet rays.

Reasons for No Return and Exchange

As this product is an electronic product that requires installation, no return or exchange is allowed for the following reasons.

(When using after installation, the value of the product significantly decreases, so it cannot be sold as a new product)

- 01 No change of mind refunds (color, price change, etc.) or exchange is allowed.
- 02 If it is not a defect that requires a major repair of the product, it cannot be exchanged or returned after installation. (Warranty applies)
- 03 No exchange or return is allowed due to individual differences. (massage strength, body size, etc.) (Recommend product testing before purchase)

Warranty Terms And Conditions

Covered :

- All parts, labor, and framework of the chair
- Labor and parts covered for the first three years at no cost to Purchaser
- Structural Framework covered at no cost to Purchaser for all five years
- Defects in materials and workmanship

All goods sold hereunder, except accompanying accessories, documentations, or enhancements, are warranted to be free from defects in material and workmanship at the time of delivery to Purchaser and covered for the above, for a period of three (3) years from the date of delivery.

Defective material may be returned to BODYFRIEND after inspection by an agent of BODYFRIEND and upon receipt from BODYFRIEND of shipping instructions specific to the defective goods authorized by BODYFRIEND to be returned.

Goods returned in accordance with the foregoing procedure will be replaced or repaired, at the option of BODYFRIEND, and returned to Purchaser without charge.

This warranty is subject to the following LIMITATIONS AND EXCLUSIONS :

Limitations :

- This express warranty applies to massage chairs ONLY, and not to accompanying accessories, documentation or enhancements;
- This warranty is non-transferable;
- This warranty is valid only within the European Union;
- BODYFRIEND's responsibility and Purchaser's exclusive remedy under this warranty is limited to the repair or replacement of defects in material and workmanship, as set forth above. BODYFRIEND is not responsible for any consequential damages resulting from the breach of this or any other express or implied warranty with respect to the goods;
- This express warranty is the only warranty applicable to this transaction. It excludes all other express oral or written warranties and all warranties implied by law with respect to the goods, including any warranties of merchantability or fitness for a particular purpose;
- This warranty does not extend to any of BODYFRIEND's products which have been subject to misuse, accident or improper installation or storage, maintenance or application, nor does it extend to products which have been repaired or altered outside of BODYFRIEND or its authorized agents, nor does this warranty extend to any labor charges for removal and/or replacement of the nonconforming or defective product or part thereof;
- Every claim under this warranty or related to this purchase order shall be deemed waived by Purchaser unless made in writing within three (3) years of the receipt of the goods to which such claim relates; AND
- This warranty is void in the event that repairs are made by anyone other than BODYFRIEND without prior authorization from BODYFRIEND.

The terms of this warranty shall be governed by the laws of the European Union.

Warranty Terms And Conditions

Exclusions :

This express warranty is void without this warranty card and requested information (date of purchase, installation, RMA, etc.).

This express warranty does not cover damage resulting from improper installation or use, neglect, dropped product, unreasonable maintenance, failure to follow instructions, unauthorized repairs, alterations, modifications of original condition, and cosmetic alternations. Furthermore, warranty does not cover damage resulting from improper use of electrical/power supply; loss of power; electrical disturbances, power surges.

Also, damage or cracked screen because of personal misuse, excessive force, transportation damage, theft, abuse, misuse, vandalism, or natural disasters (fires, floods, rust, corrosion, sand, dirt, windstorms, hail, earthquakes, or any exposure to weather conditions) are not covered under stated warranty.

BODYFRIEND does not honor warranty for products purchased by or through unauthorized dealers, product used commercially or for commercial purposes, and time lost by owner during the time the product is being replaced, at a repair facility, etc. Natural occurrences such as, but not limited to softening/hardening of foams and composites, fading, wear, pilling of fabrics, natural markings, grain and dye variations in leather, and failure of attach points does not validate issue of warranty, as well as items intended to be periodically replaced by Purchaser during the normal lifetime of a product including, but not limited to batteries, light bulbs, and etc. Seat cover replacement and other accessories are not covered under warranty.

Labor :

Only for the first three years of the warranty period (“Labor Service Period”), BODYFRIEND will provide labor services for the repair or replacement of defective parts at no cost to Purchaser. However, Purchaser is responsible for all shipping, duties, and brokerage fees.

Upon expiration of the Labor Service Period, Purchaser shall pay for any labor service charges.

Labor services are limited to the replacement of the defective product or parts with a similar product of equal or less value. If replacement is not accepted by Purchaser, BODYFRIEND or its labor service provider is no longer responsible for further service under this labor warranty. If and only when deemed necessary at its sole discretion, BODYFRIEND will send a service provider at no cost.

*Listed years vary by product

BODYFRIEND

+33 1 47 72 05 05

france@bodyfriend.com

Memo

Memo

DAVINCI

Product Name Electrical massager
Model BFB-8210EU
Customer Service france@bodyfriend.com / +33 1 47 72 05 05
Manual No. 231206

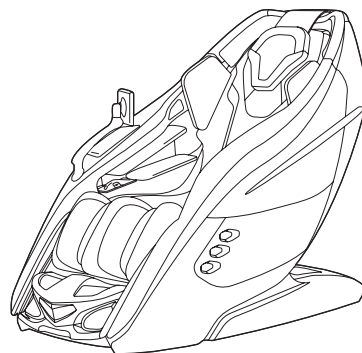

 Please remove this manual according to the local separate waste collection rules.
