



Manual Zipper Screen Installation Instruction

Section 1 -Tools	-----	P2
Section 2 -Installations	-----	P3-P8



Section 1 Tools required:

 Electric Drill	 Philips Head	 Screw Driver (Flat Head)	 Allen Key Set (3mm)
 Self Tapper Screws	 Levelling Instrument	 Motor Regulator	 Electrical Adhesive Tape
 Wire Clamp	 Measuring Tape		

***Motor Regulator, Electrical Adhesive Tape, Wire Clamp is for motorize unit only.

Section 2 Installation

Step 1:

Clear work area and lay all parts to ensure all parts are contained in the box

*****NOTE: Before installing, double check the sides are level. (not level could cause the screen to fail overtime) *****

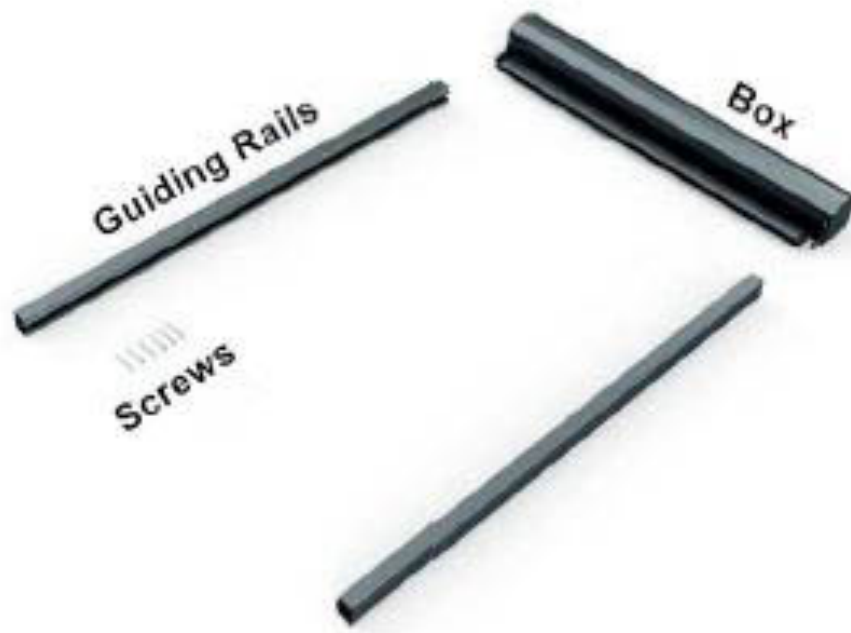

Remove front cover

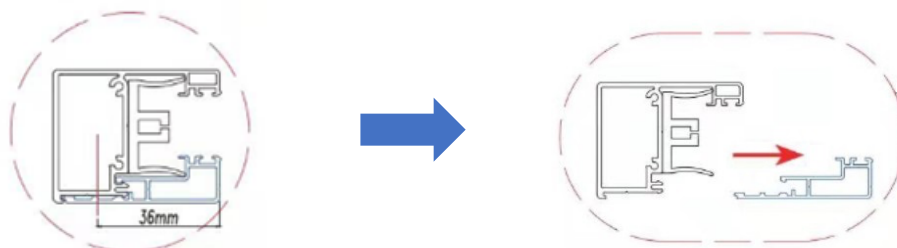

Step 2:

Before installing, lift up the screen and pull down and push upward to double check if the screen can retract back to the top without falling down after you push up. If it slide down after push up, you will need to follow the increase tension instruction on our website Q&A section to increase its tension little by little until it is completely stay up.

*****NOTE:** Failed to check tension could result in taking the screen down and reinstall it again.

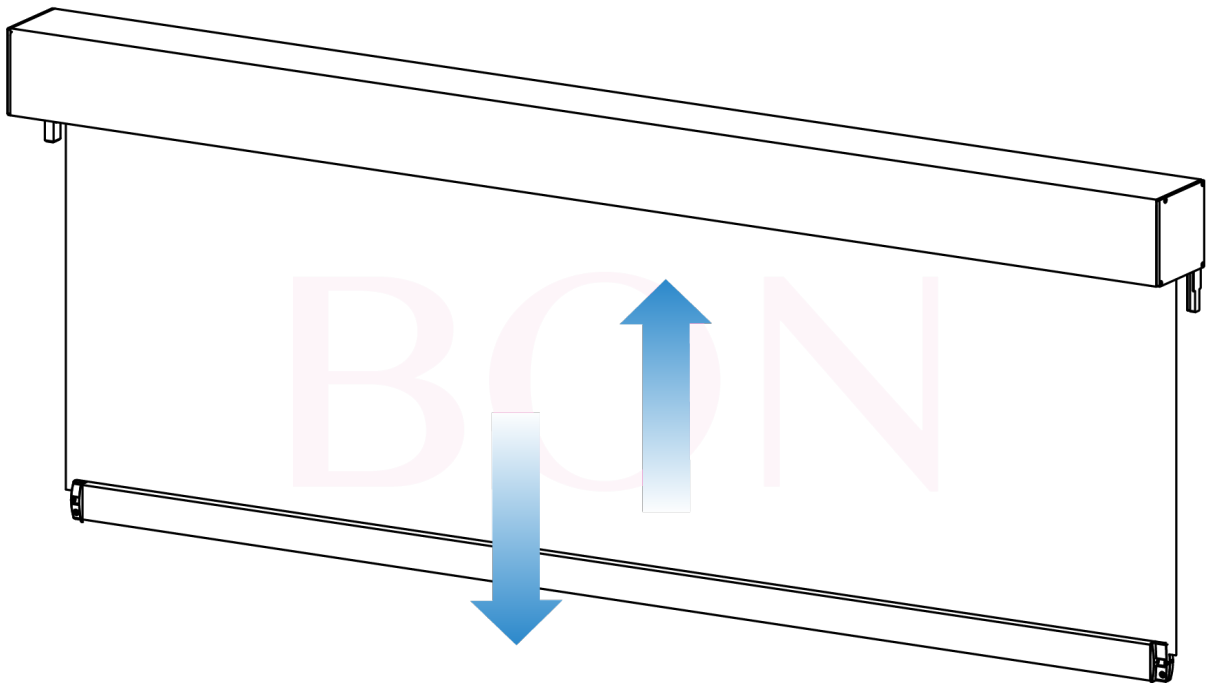

Step 3:

Pre Drill holes for the screw to connect the side channel and the pergola post later.

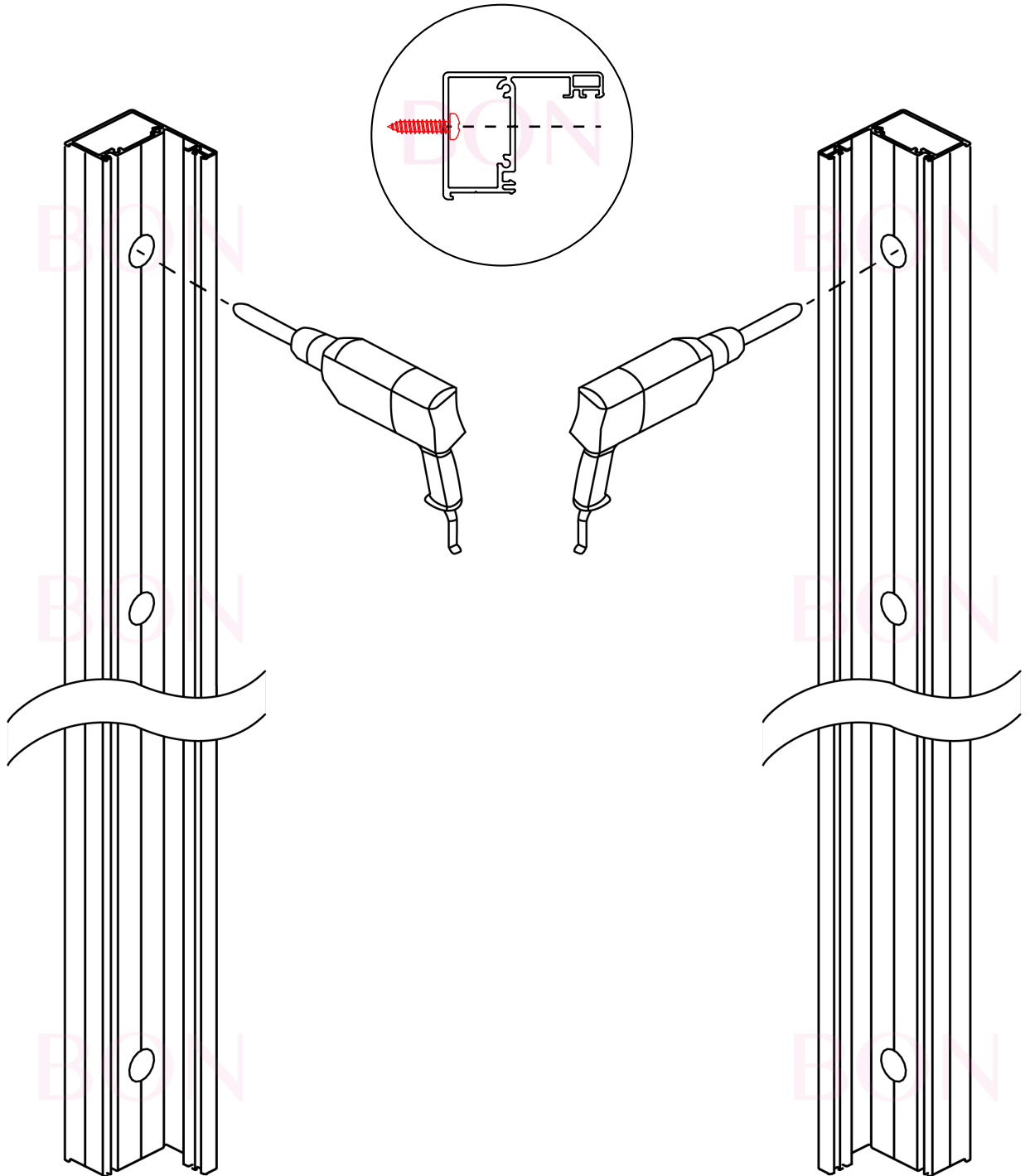

Step 4:

Separate the front rail, plastic zipper guide insert, and back rails. Insert the back rails into sides of box cassette (so they are in one piece), then screw it onto the pergola with self-tapping screws on each side.

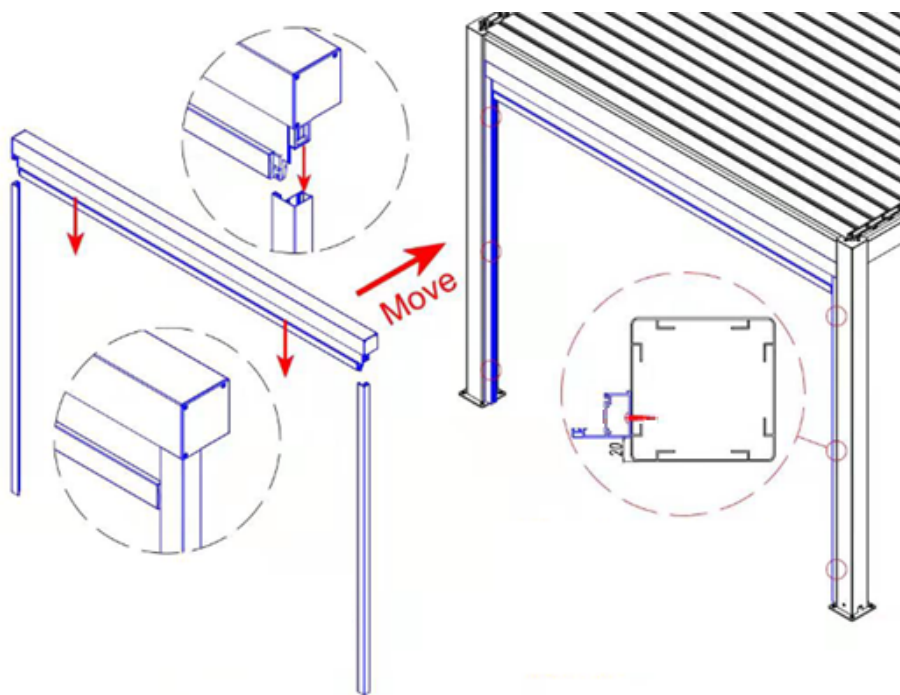

*** Note, plan which side you want the screen to align to before screwing the side rail. ***

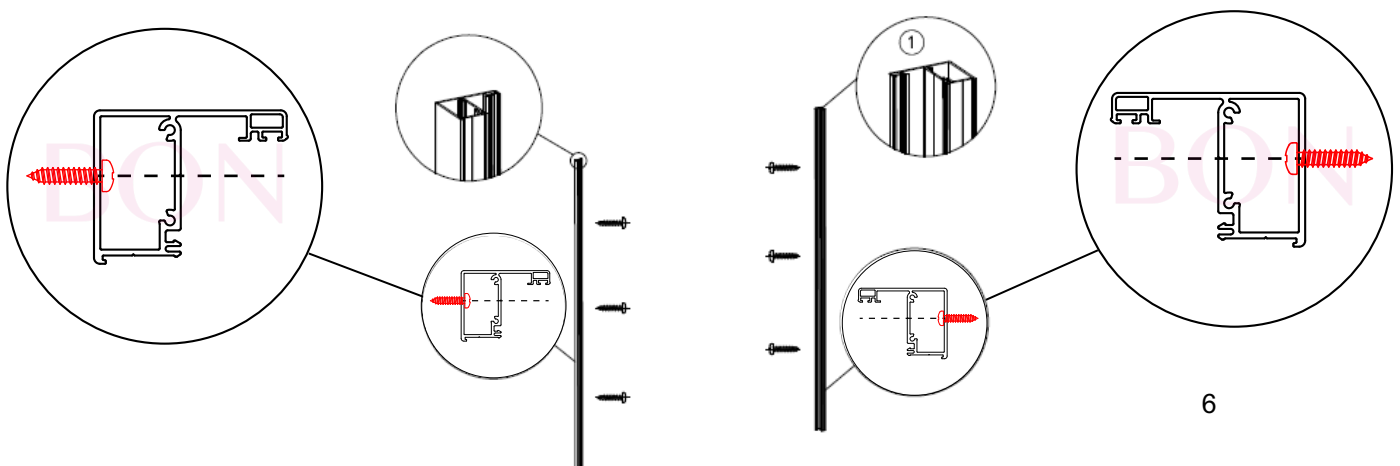

Step 5:

Insert the zipper with fabric into the plastic zipper guide
insert rails and align it to the side rail .

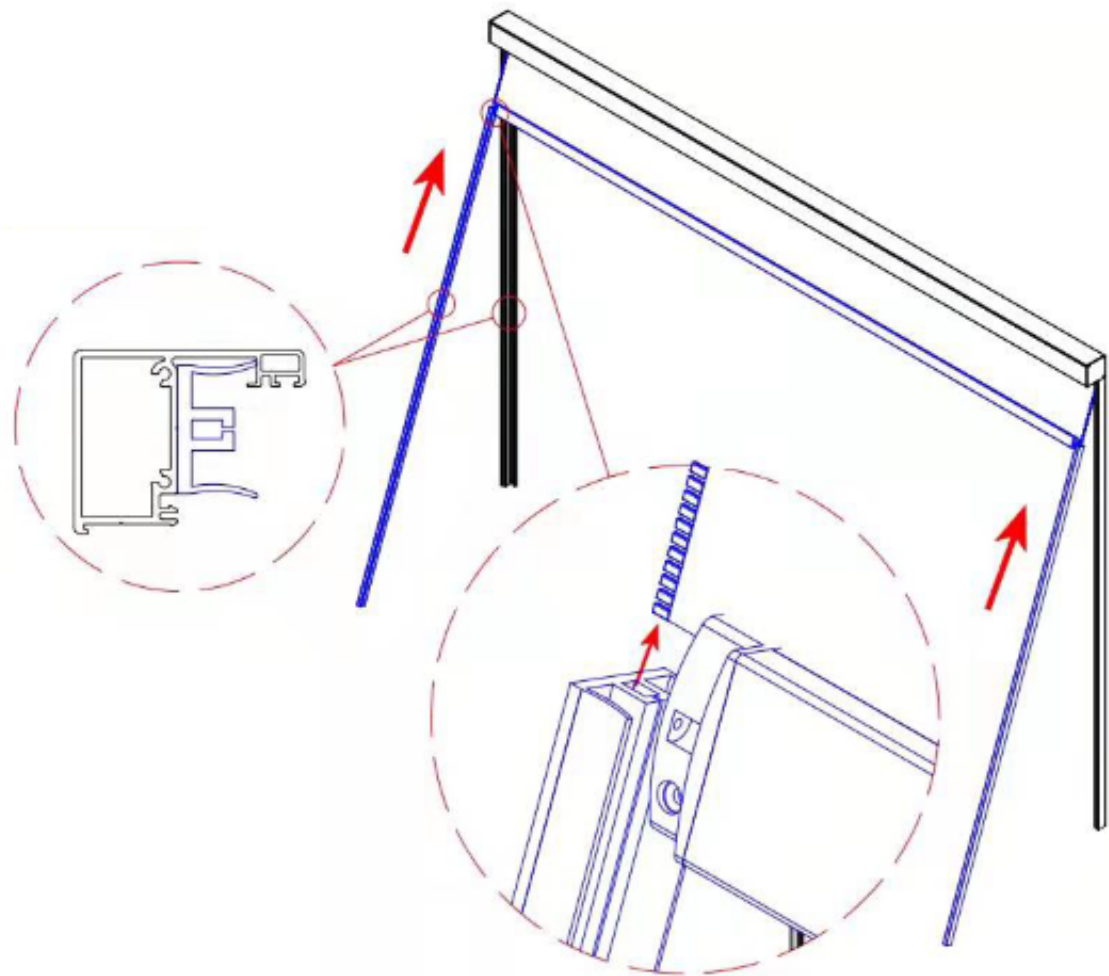

Step 6:

Assemble the front rail tight by pushing the front rail into the back rail (while the plastic zipper guide insert is within).

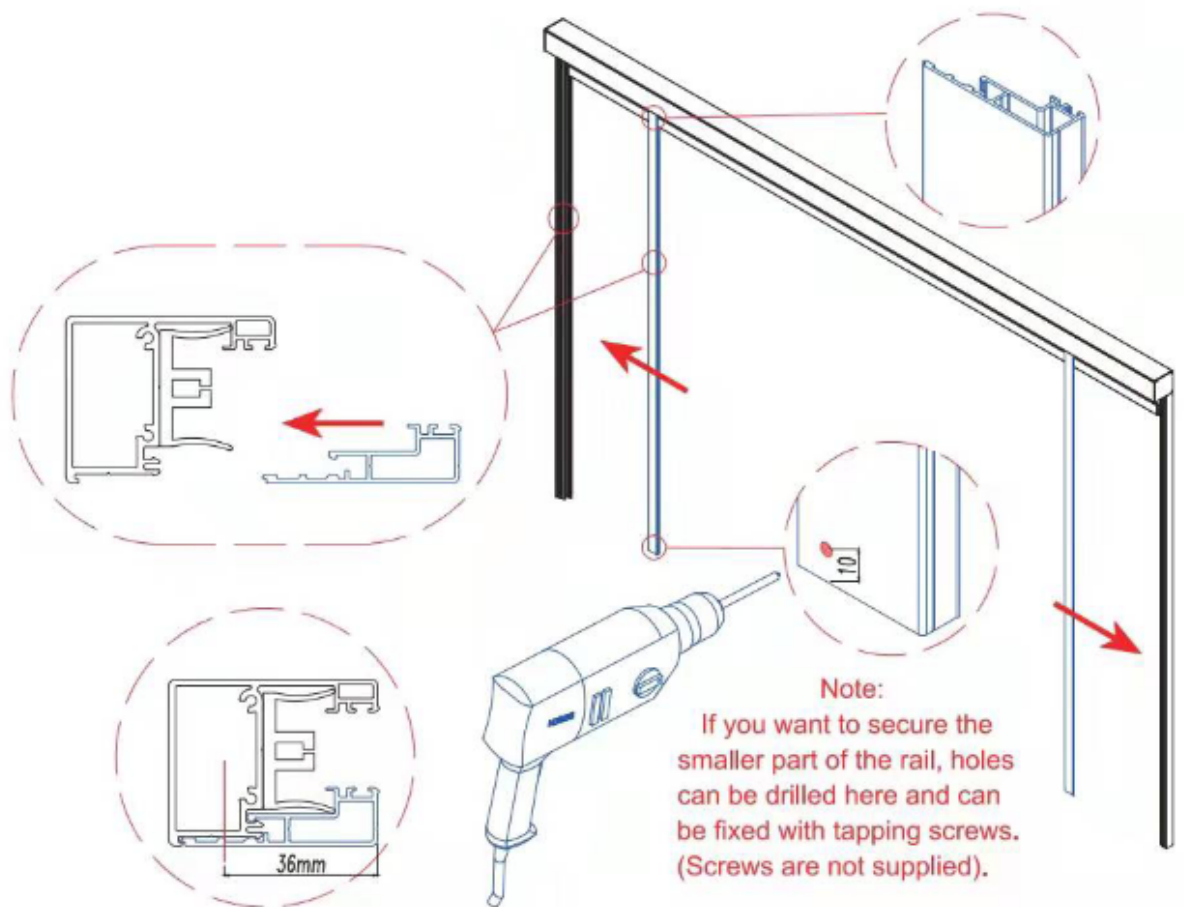

Step 7:

Pull the fabric down only after the screen is fully assembled for testing.