

# Pleasant Hearth®

## 12 FT. HEAVY DUTY LOG RACK

MODEL #LS938-144

*Español p.6*

*Français p.11*

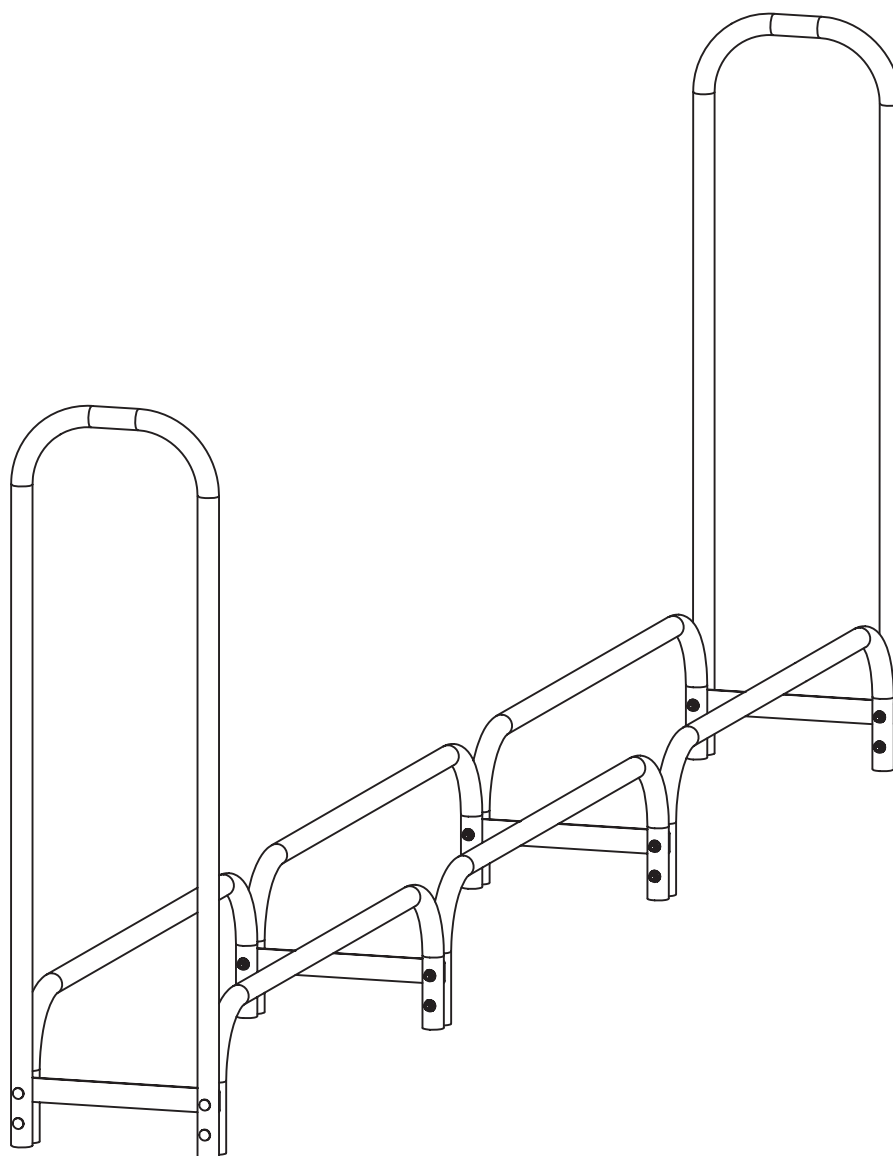

**ATTACH YOUR RECEIPT HERE**

Serial Number \_\_\_\_\_ Purchase Date \_\_\_\_\_



**Questions, problems, missing parts?** Before returning to your retailer, call our customer service department at 1-877-447-4768, 8:00 a.m. – 4:30 p.m., CST, Monday – Friday, or email us at [customerservice@ghpgroupinc.com](mailto:customerservice@ghpgroupinc.com).

## PACKAGE CONTENTS

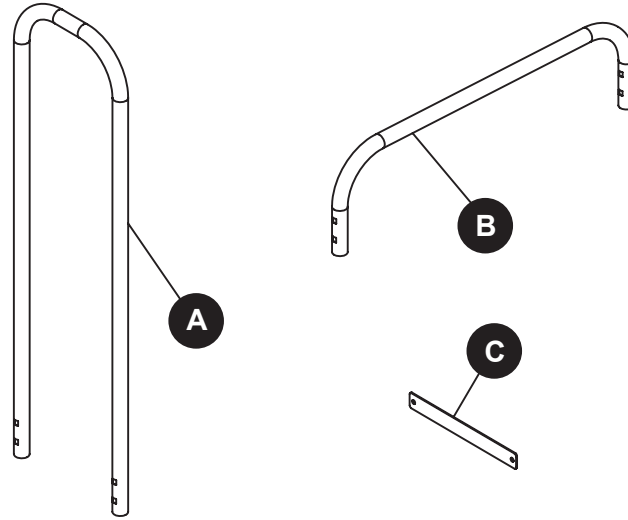

PART	DESCRIPTION	QUANTITY
A	Vertical Ends	2
B	Horizontal Base Bars	6
C	Spreader Bar	4

## HARDWARE CONTENTS

AA



M8x90mm Carriage Bolt  
Qty. 16

BB



Nut  
Qty. 16

CC



Washer  
Qty. 16

DD



Wrench  
Qty. 1

## SAFETY INFORMATION

Please read and understand this entire manual before attempting to assemble, operate or install the product.

### WARNING

- Do not allow children to play with or around log rack.

### CAUTION

- Place rack on hard, dry surface.
- Protect rack from moisture.

## PREPARATION

Before beginning assembly of product, make sure all parts are present. Compare parts with package contents list and hardware contents above. If any part is missing or damaged, do not attempt to assemble the product. Contact customer service for replacement parts.

**Estimated Assembly Time:** 20 minutes

Tools Required for Assembly (included): Wrench





## ASSEMBLY INSTRUCTIONS

1. Attach two horizontal base bars (B) to the vertical end (A) by inserting 4 carriage bolts (AA) through the predrilled holes in the vertical end (A), the predrilled holes in the spreader bar (C), and the predrilled holes in the horizontal base bars (B). Insert two washers (CC) between the vertical end (A) and the spreader bar (C) on the bottom hole only. Then, insert two washers (CC) between the spreader bar (C) and the horizontal base bars (B) on the bottom hole only. Then secure all bolts with nuts (BB). Tighten with the wrench (DD).

Repeat with the second vertical end (A), two additional horizontal base bars (B), and the second spreader bar (C).



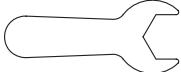

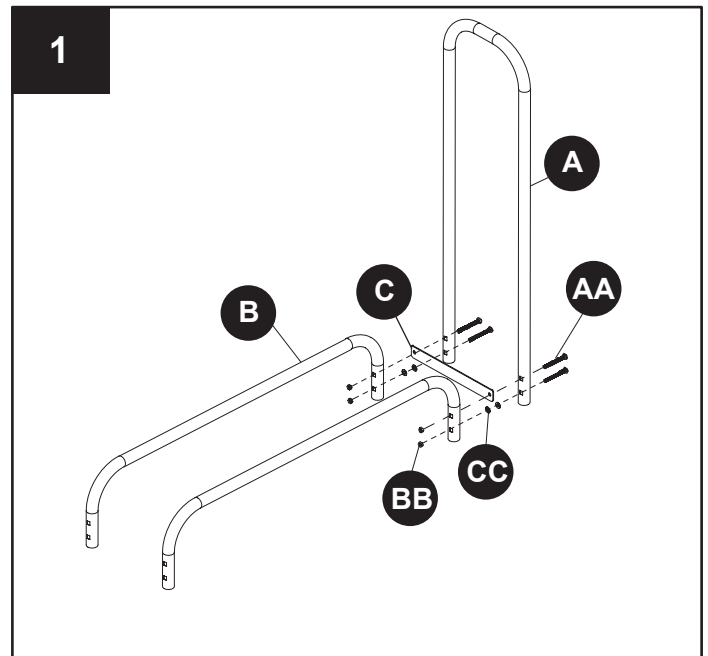
### Hardware Used

<b>AA</b>	M8x90mm Carriage Bolt		x 4
<b>BB</b>	Nut		x 4
<b>CC</b>	Washer		x 4
<b>DD</b>	Wrench		



2. Attach the remaining horizontal base bars (B) to the completed end assemblies by inserting 8 carriage bolts (AA) through the predrilled holes in the horizontal base bars (B) and the remaining two spreader bars (C). Insert two washers (CC) between the completed assemblies on the bottom holes only, then secure all bolts with nuts (BB). Tighten with the wrench (DD).

### Hardware Used

<b>AA</b>	M8x90mm Carriage Bolt		x 8
<b>BB</b>	Nut		x 8
<b>CC</b>	Washer		x 8
<b>DD</b>	Wrench		

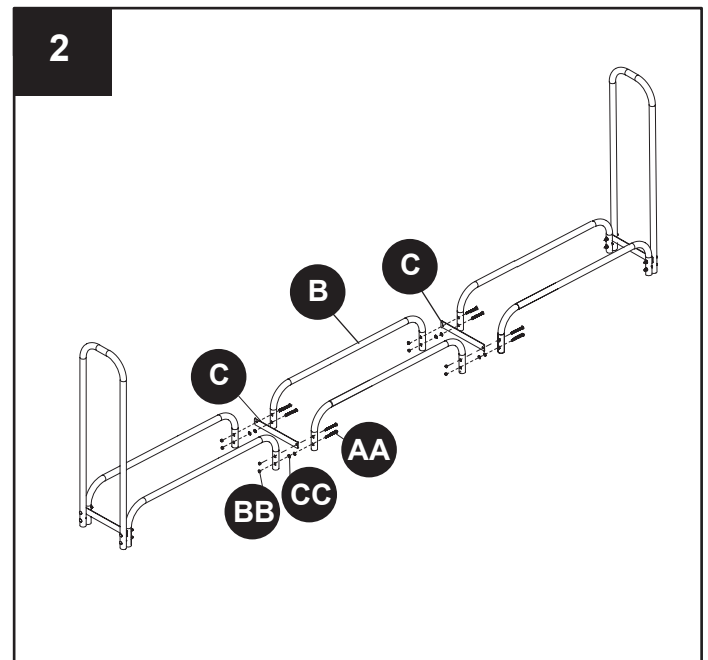

## CARE AND MAINTENANCE

- Keep the log rack protected from elements.
- Do not attempt to overload the rack.

## **WARRANTY**

---

If within 25 years from the date of original purchase, this log rack fails due to a defect in material or workmanship, we will replace or repair at our option, free of charge. This warranty does not cover defects resulting from improper or abnormal use, misuse, accident, alteration, damage that is attributable to acts of God, common erosion of outdoor products or use in a commercial application. Failure to follow all instructions in the owner's manual will also void this warranty. Proof of purchase will be required before warranty service is rendered. The manufacturer will not be liable for incidental or consequential damages. Some states do not allow the exclusion or limitation of incidental or consequential damages, so the above limitation or exclusion of incidental or consequential damages may not apply to you. This warranty gives you specific legal rights, and you may also have other rights which vary from state to state.



**GHP Group Inc.**  
6440 W. Howard St.  
Niles, IL 60714-3302  
877-447-4768

## REPLACEMENT PARTS LIST

For replacement parts, call our customer service department at 1-877-447-4768, 8:00 a.m. - 4:30 p.m., CST, Monday - Friday.

PART	DESCRIPTION	PART #
A	Vertical Ends	LSP-38RVE
B	Horizontal Base Bars	LSP-38RHB
C	Spreader Bar	LSP-SB
AA-DD	Hardware Bag	HWP-12FT
N/A	Instruction Manual	40-10-131

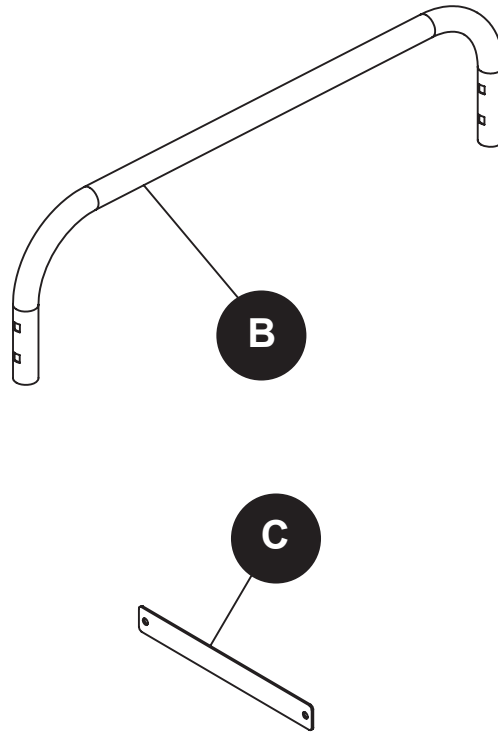
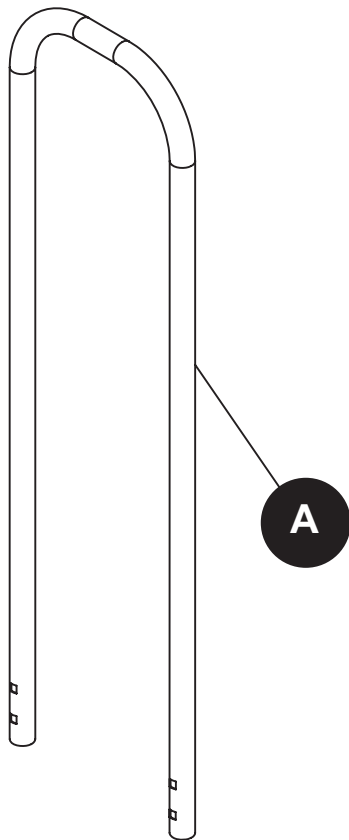
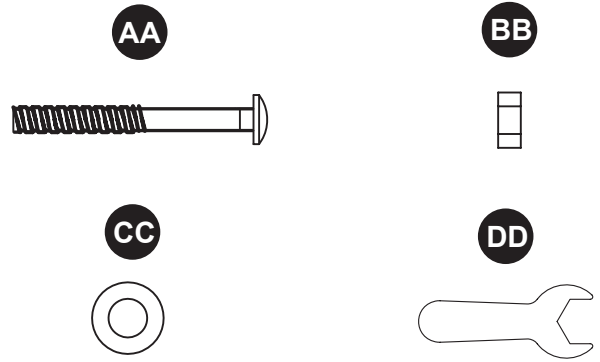

# Pleasant Hearth®

## ESTANTE RESISTENTE PARA LEÑA DE 12 PIES

MODELO #LS938-144

English p. 1

Français p. 11

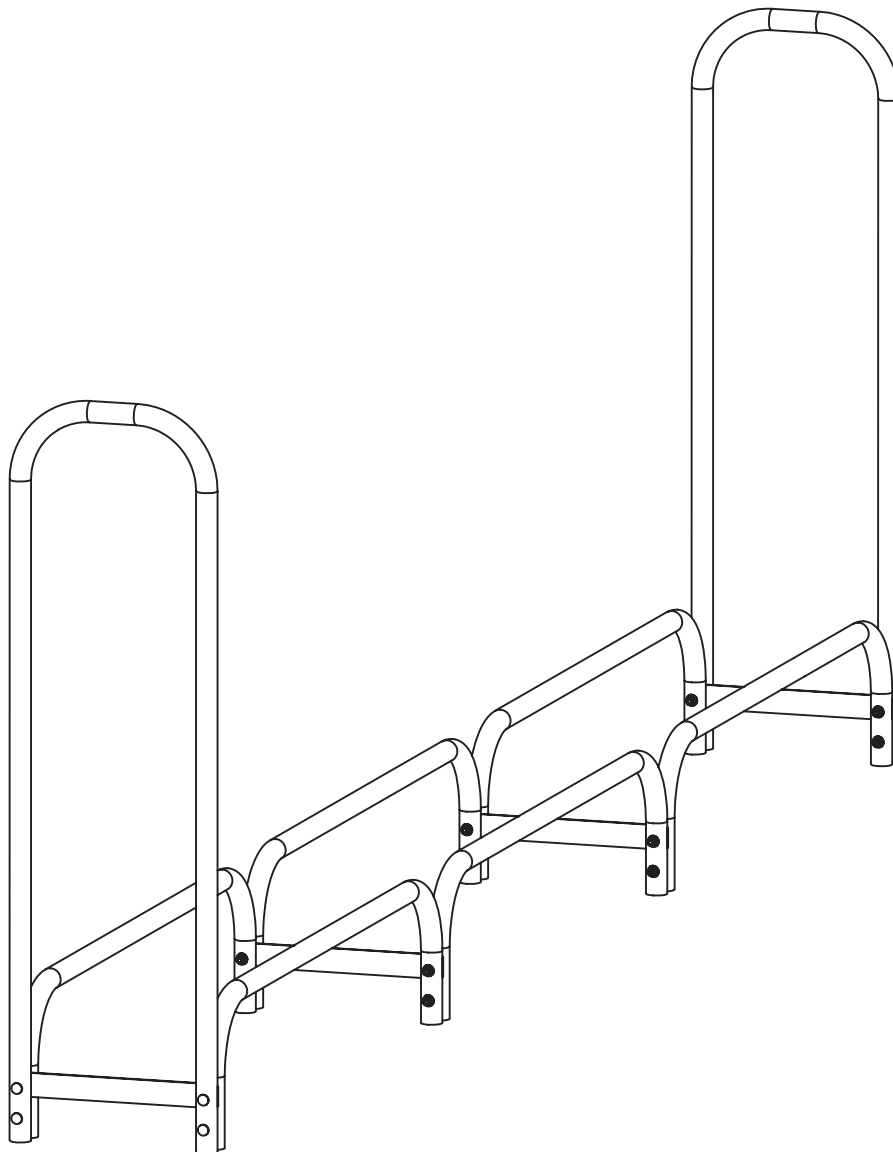

ADJUNTE SU RECIBO AQUÍ

Número de serie \_\_\_\_\_ Fecha de compra \_\_\_\_\_



### ¿Preguntas, problemas, piezas faltantes?

Antes de volver a la tienda, llame a nuestro departamento de servicio al cliente al 1-877-447 4768, de lunes a viernes de 8:00 a.m. a 4:30 p.m., hora central estándar o envíenos un correo electrónico a [customerservice@ghpgroupinc.com](mailto:customerservice@ghpgroupinc.com)

## CONTENIDO DEL PAQUETE

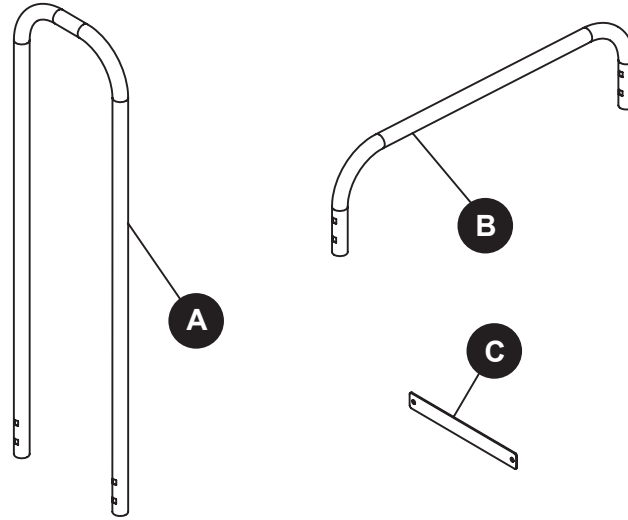

PIEZA	DESCRIPCIÓN	CANTIDAD
A	Extremos verticales	2
B	Barras horizontales de base	6
C	Barra separadora	4

## ADITAMENTOS

AA



M8x90mm Perno  
Cant.16

BB



Tuerca  
Cant. 16

CC



Arandela  
Cant. 16

DD



Llave  
Cant. 1

## ⚠ INFORMACIÓN DE SEGURIDAD

Lea y comprenda completamente este manual antes de intentar ensamblar, usar o instalar el producto.

### ⚠ ADVERTENCIA

- No permita que los niños jueguen con el soporte para leños o cerca de él.

### ⚠ PRECAUCIÓN

- Coloque el soporte en una superficie dura y seca.
- Protéjalo de la humedad.

## PREPARACIÓN

Antes de comenzar a ensamblar el producto, asegúrese de tener todas las piezas. Compare las piezas con la lista del contenido del paquete y los aditamentos mencionados anteriormente. No intente ensamblar el producto si falta alguna pieza o si éstas están dañadas. Póngase en contacto con el Departamento de Servicio al Cliente para obtener piezas de repuesto.

**Tiempo estimado de ensamblaje:** 15 minutos

Herramientas necesarias para el ensamblaje (incluida): Llave





## INSTRUCCIONES DE ENSAMBLAJE

1. Junte las dos barras horizontales de base (B) a los bordes verticales (A) insertando los 4 pernos (AA) por los agujeros perforados en la barra vertical (A), los agujeros perforados en la barra distribuidora (C) y los agujeros perforados en las barras horizontales (B). Inserte dos arandelas (CC) entre el extremo vertical (A) y la barra separadora (C) únicamente en el orificio inferior. Luego, inserte dos arandelas (CC) entre la barra separadora (C) y las barras horizontales de base (B) únicamente en el orificio inferior. Luego, asegure todos los pernos con tuercas (BB). Ajuste con una llave inglesa (DD).

Repita lo mismo con la segunda barra vertical del borde (A), dos barras horizontales de base (B), y la segunda barra separadora (C).

x 4



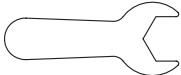

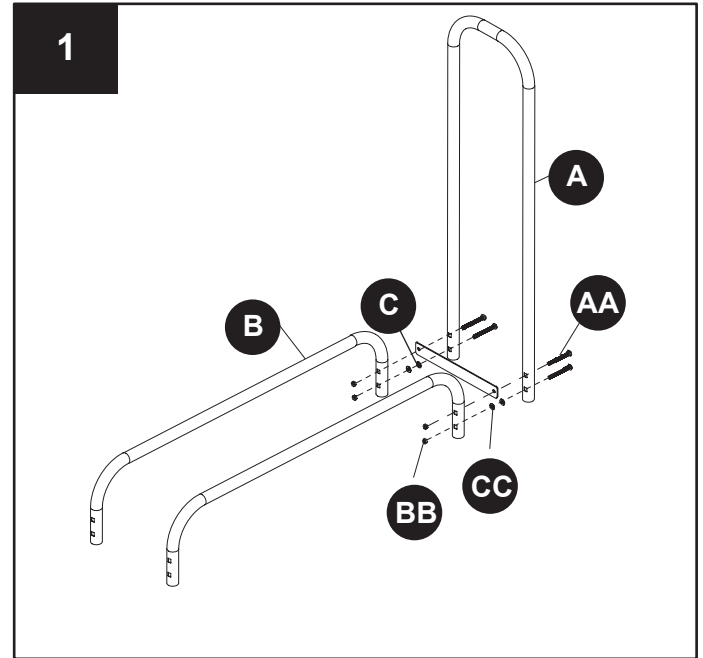
### Ferreteria utilizado

<b>AA</b>	M8x90mm Perno		x 4
<b>BB</b>	Tuerca		x 4
<b>CC</b>	Arandela		
<b>DD</b>	Llave		



2. Junte las restantes barras horizontales de base (B) a los ensamblajes completados insertando 8 pernos (AA) por los agujeros perforados en las bases horizontales (B) y las restantes barras separadoras (C). Inserte dos arandelas (CC) entre los ensamblajes completados solamente en los agujeros del fondo, luego ajuste todos los pernos y tuercas (BB). Ajuste con una llave inglesa (DD).

### Ferreteria utilizado

<b>AA</b>	M8x90mm Perno		x 8
<b>BB</b>	Tuerca		x 8
<b>CC</b>	Arandela		x 8
<b>DD</b>	Llave		

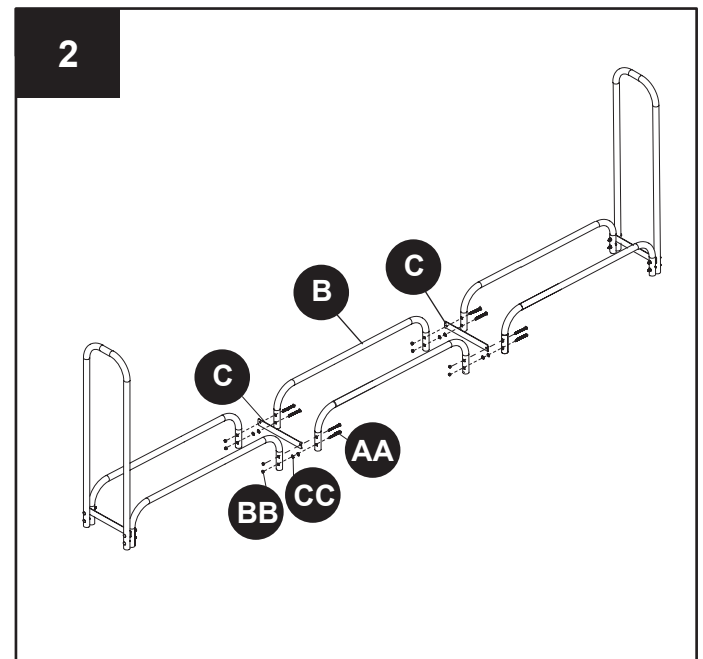

## CUIDADO Y MANTENIMIENTO

- Mantenga el soporte para leños protegido de los elementos.
- No intente estante el soporte.



## **GARANTÍA**

---

Si dentro de los 25 años de la fecha original de la compra este estante para leña falla debido a defecto de fabricación o material, se la reemplazaremos o se la repararemos, de acuerdo a nuestro criterio, sin cargo. Esta garantía no lo cubre por defectos debido al uso inadecuado o inapropiado, o por accidente o alteraciones y daños atribuidos como fuerza mayor, erosión común en productos de uso al aire libre o por uso comercial. Si este producto se usa sin seguir las instrucciones en el manual la garantía quedará cancelada. Se requiere prueba de la compra antes de recibir el servicio de garantía. El fabricante no será responsable por daños fortuitos o causales. Algunos estados no permiten la exclusión o limitación de daños fortuitos o causales entonces esta limitación o exclusión por daños fortuitos o causales puede no ser aplicable a su situación. Esta garantía le otorga derechos legales específicos, y Ud puede también tener otros derechos que varían de un estado al otro.



**GHP Group Inc.**  
6440 W. Howard St.  
Niles, IL 60714-3302  
877-447-4768

## LISTA DE PIEZAS DE REPUESTO

Para obtener piezas de repuesto, llame a nuestro Departamento de Servicio al Cliente al 1-877-447-4768, de 8:00 a.m. a 4:30 p.m. hora central estándar, de lunes a viernes.

PIEZA	DESCRIPCIÓN	PIEZA #
A	Extremos Verticales	LSP-38RVE
B	Barras Horizontales de Base	LSP-38RHB
C	Barra Separadora	LSP-SB
AA-DD	Bolsa de Herraje	HWP-12FT
N/A	Manual de instrucciones	40-10-131

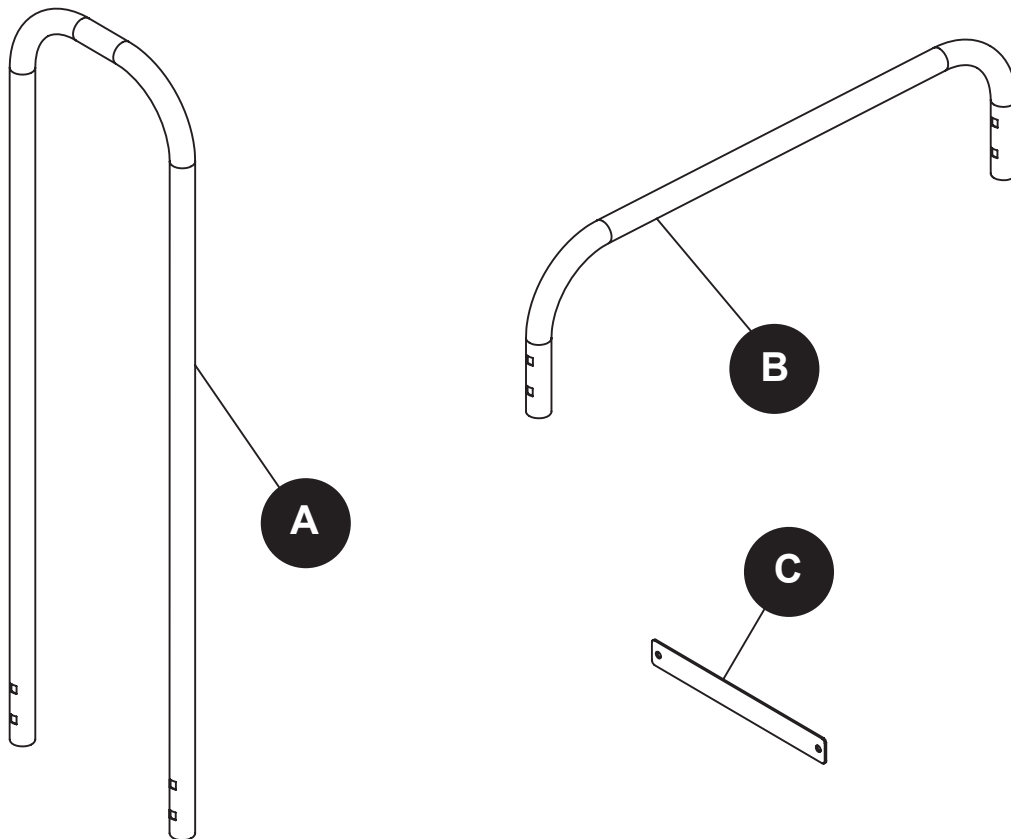
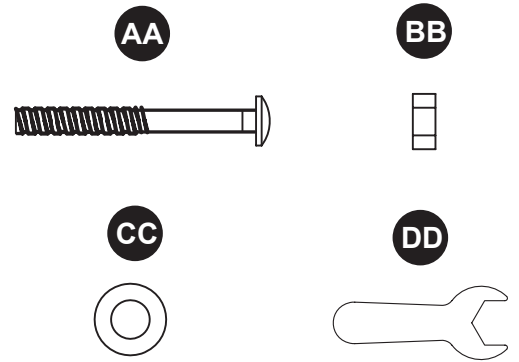

# Pleasant Hearth®

## 3,66 METRES PORTE-BUCHES A USAGE INDUSTRIEL

MODÈLE #LS938-144

English p.1

Español p.6

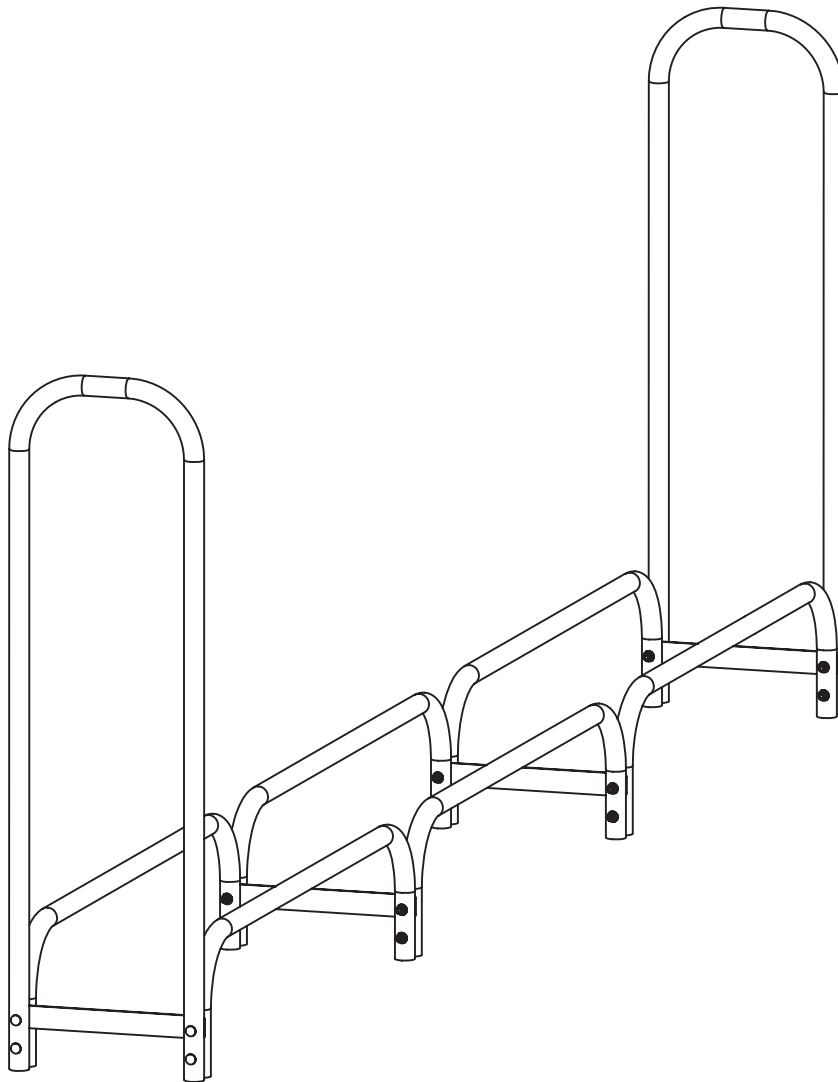

ATTACHEZ VOTRE REÇU ICI

Numéro de série \_\_\_\_\_ Date d'achat \_\_\_\_\_



**Questions, problèmes, pièces manquantes?** Avant de contacter votre détaillant, contactez notre centre de service à la clientèle au 1-877-447-4768 entre 08h00 à 16h30, heure du Centre du lundi au vendredi, ou nous envoyer un courriel à [customerservice@ghpgroupinc.com](mailto:customerservice@ghpgroupinc.com).

## CONTENU DE L'EMBALLAGE

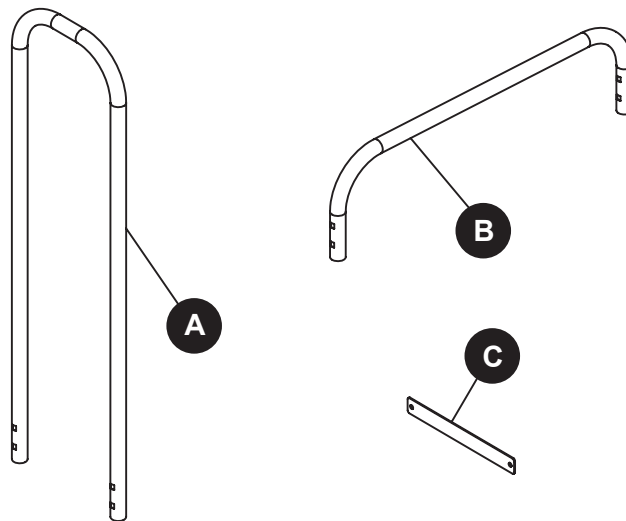

PIÈCE	DESCRIPTION	QUANTITÉ
A	Extrémités Verticales	2
B	Barres Horizontales de Base	6
C	Barre d'Ecartement	4

## ADITAMENTOS

AA



M8x90mm Boulon  
Qté 16

BB



Écrou  
Qté 16

CC



Rondelle  
Qté 16

DD



Clé  
Qté 1

## ⚠️ CONSIGNES DE SÉCURITÉ

Assurez-vous de lire et de comprendre l'intégralité du présent manuel avant de tenter d'assembler, d'installer ou d'utiliser l'article.

### ⚠️ AVERTISSEMENT

- Ne laissez pas les enfants jouer avec le support à bûches ou à proximité de celui-ci.

### ⚠️ MISE EN GARDE

- Placez le support sur une surface dure et sèche.
- Protégez le support de l'humidité.

## PRÉPARATION

Avant de commencer l'assemblage du produit, assurez-vous d'avoir toutes les pièces. Comparez les pièces avec la liste du contenu de l'emballage et celle de la quincaillerie ci-dessus. S'il y a des pièces manquantes ou endommagées, ne tentez pas d'assembler le produit. Communiquez avec le service à la clientèle pour obtenir des pièces de rechange.

**Temps d'assemblage approximatif:** 20 minutes

Outil nécessaire pour l'assemblage (incluse) : Clé

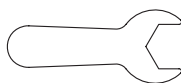





## INSTRUCTIONS POUR L'ASSEMBLAGE

1. Attacher 2 barres horizontales de base (B) à l'extrémité verticale (A) en insérant 4 boulons (AA) dans les trous prépercés de l'extrémité verticale (A), dans les trous prépercés de la barre d'écartement (C), dans les trous prépercés des barres horizontales de base (B). Insérez deux rondelles (CC) entre l'extrémité verticale (A) et la barre d'espacement (C), pour les trous du bas seulement. Ensuite, insérez deux rondelles (CC) entre la barre d'espacement (C) et les barres horizontales de la base (B), pour les trous du bas seulement. Serrez les boulons à l'aide des écrous (BB). Serrer avec la clé (DD).

Répéter avec la deuxième extrémité verticale (A), deux barres horizontales de base supplémentaires (B) et la deuxième barre d'écartement (C).



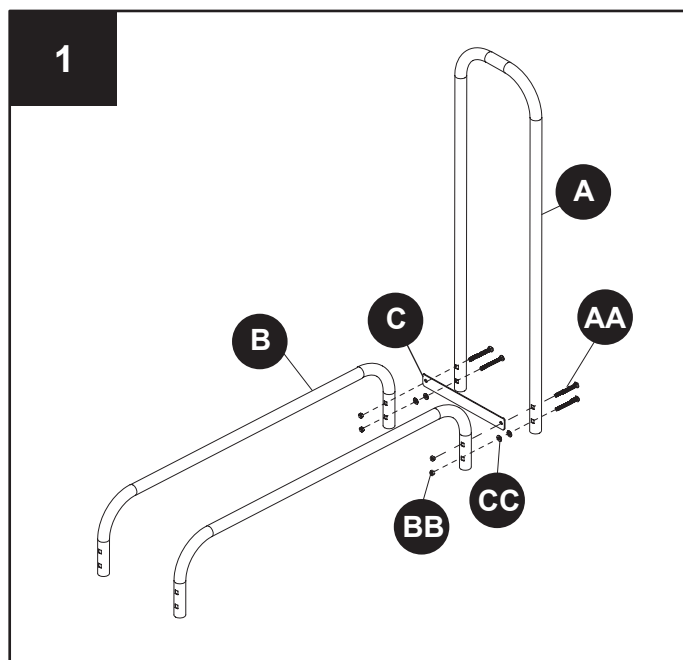

### Matériel utilisé

<b>AA</b>	M8x90mm Boulon		x 4
<b>BB</b>	Écrou		x 4
<b>CC</b>	Rondelle		x 4
<b>DD</b>	Clé		



2. Attacher les barres horizontales de base (B) qui restent pour terminer le montage en insérant 8 boulons (AA) dans les trous prépercés des barres horizontales de base (B) ainsi que les 2 barres d'écartement (C) qui restent. Insérer 2 rondelles (CC) entre les assemblages effectués (dans les trous inférieurs seulement) puis fixer tous les boulons avec des écrous (BB). Serrer avec la clé (DD).

### Matériel utilisé

<b>AA</b>	M8x90mm Boulon		x 8
<b>BB</b>	Écrou		x 8
<b>CC</b>	Rondelle		x 8
<b>DD</b>	Clé		

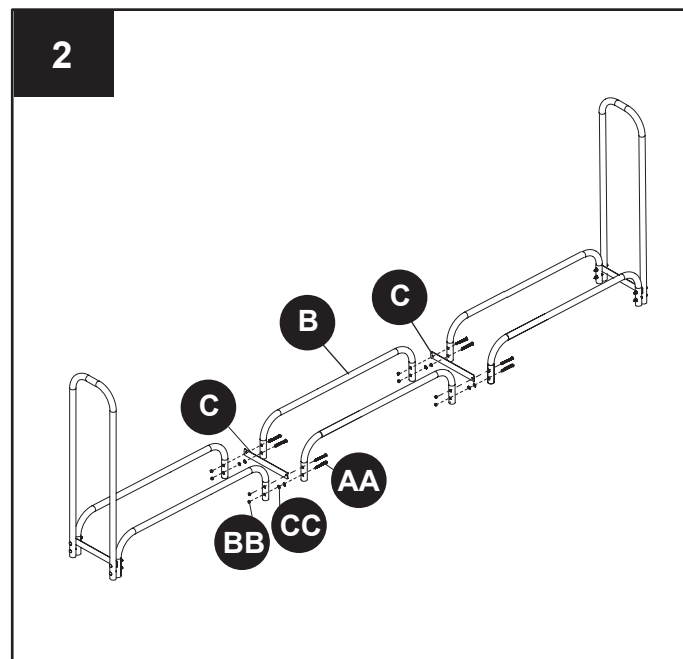

## ENTRETIEN

- Protégez le support à bûches des intempéries.
- Évitez de surcharger le support.

## **GARANTIE**

---

Durant les 25 ans, à compter de sa date d'achat, si ce porte-bûches fait défaut en raison d'un problème défectif de matériaux ou de fabrication, nous vous le remplacerons ou le réparerons, à notre discrétion et sans frais pour vous. Cette garantie ne couvre pas les défauts résultant d'un mauvais usage, d'une utilisation anormale, abusive, d'un accident, d'une modification, d'un dégât suite à un désastre naturel, d'une érosion commune à des produits laissés en plein air ou utilisés à des fins commerciales. Aussi, la garantie sera annulée si les instructions contenues dans le manuel du fabricant ne sont pas suivies. Une preuve d'achat sera exigée avant que toute réparation garantie soit rendue. Le fabricant ne sera pas tenu responsable des dégâts directs ou indirects. Certains Etats ne permettent pas l'exclusion ou la limitation des dégâts fortuits ou consécutifs ce qui fait que la limitation ou l'exclusion de ces derniers peuvent ne pas s'appliquer à vous. Cette garantie vous donne des droits précis et vous pouvez également en avoir d'autres puisqu'ils varient d'un Etat à un autre.



**GHP Group Inc.**  
6440 W. Howard St.  
Niles, IL 60714-3302  
877-447-4768

## LISTE DES PIÈCES DE RECHANGE

Pour obtenir des pièces de rechange, communiquez avec notre service à la clientèle au 1 877 447-4768, entre 8 h 00 et 16 h 30 (HNC), du lundi au vendredi.

PIÈCE	DESCRIPTION	N° DE PIÈCE
A	Extrémités Verticales	LSP-38RVE
B	Barres Horizontales de Base	LSP-38RHB
C	Barre d'Ecartement	LSP-SB
AA-DD	Sac de Quincailleries	HWP-12FT
N/A	Manuel d'instructions	40-10-131

