

BREANNE

STUDIO COLLECTION

H | S

AS SHOWN:

Tub only

FEATURES SHOWN:

- Exterior
- * Linear Integral Drain (standard)
- Polished Chrome Drain
- Adjustable Legs
- Built in Faucet Deck

ALSO AVAILABLE:

- Thermal Air

SIZE:

66.36.25

WATER CAPACITY:

70 Gallons

WEIGHT:

185 pounds

TECHNICAL REQUIREMENTS FOR SYSTEMS:

- Requires 15 Amp Dedicated GFCI



The Breanne is the pinnacle of elegance with its delicate curves and its reflection of an antique freestanding bathtub. This acrylic freestanding bathtub will transform a typical bathing experience into a spa-like soaking occurrence. Visit <http://www.hydrosystem.com> for more details on our options and accessories.

OPTIONS:

- Island Tub Drain
- Thermal Air System
 - With Variable Speed Blower Air Switch
 - Activated with Pulse and Wave Mode
- Hydro Express Quick Ship
- Hydro Coat

CODES AND COMPLIANCES

Massachusetts code File no: P1-0614-491



HYDRO SYSTEMS
Family Owned And Operated Since 1978

29132 Avenue Paine, Valencia, CA, 91355
661.775.0686 | hydrosystem.com

* Indicates options that are shown (listed in order from top to bottom/
left to right)

BREANNE

STUDIO COLLECTION

H | S



ACRYLIC TUB

- Acrylic models finished in 1/8" thick layer of deep lustrous acrylic
- Extra thick reinforced fiberglass

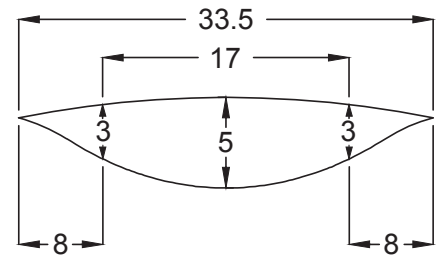
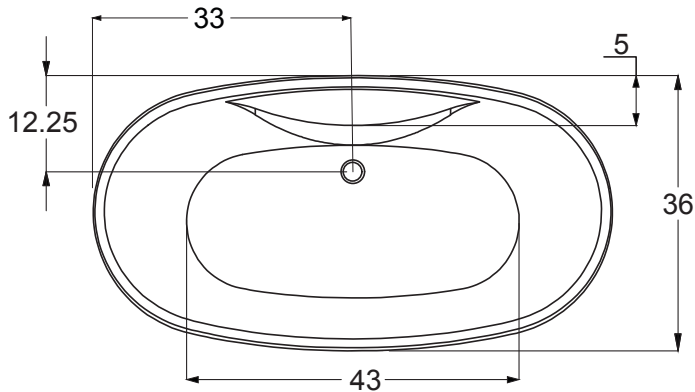

Faucet deck

