

Before connecting the faucet to the water supply flush the tubing thoroughly to eliminate any residue/  
Antes de conectar la grifería a la distribución de agua, purgue muy bien la cañería a fin de eliminar partículas extrañas.

**FV203/F4.0** - Wall mounted lavatory faucet/ Juego de lavatorio de pared

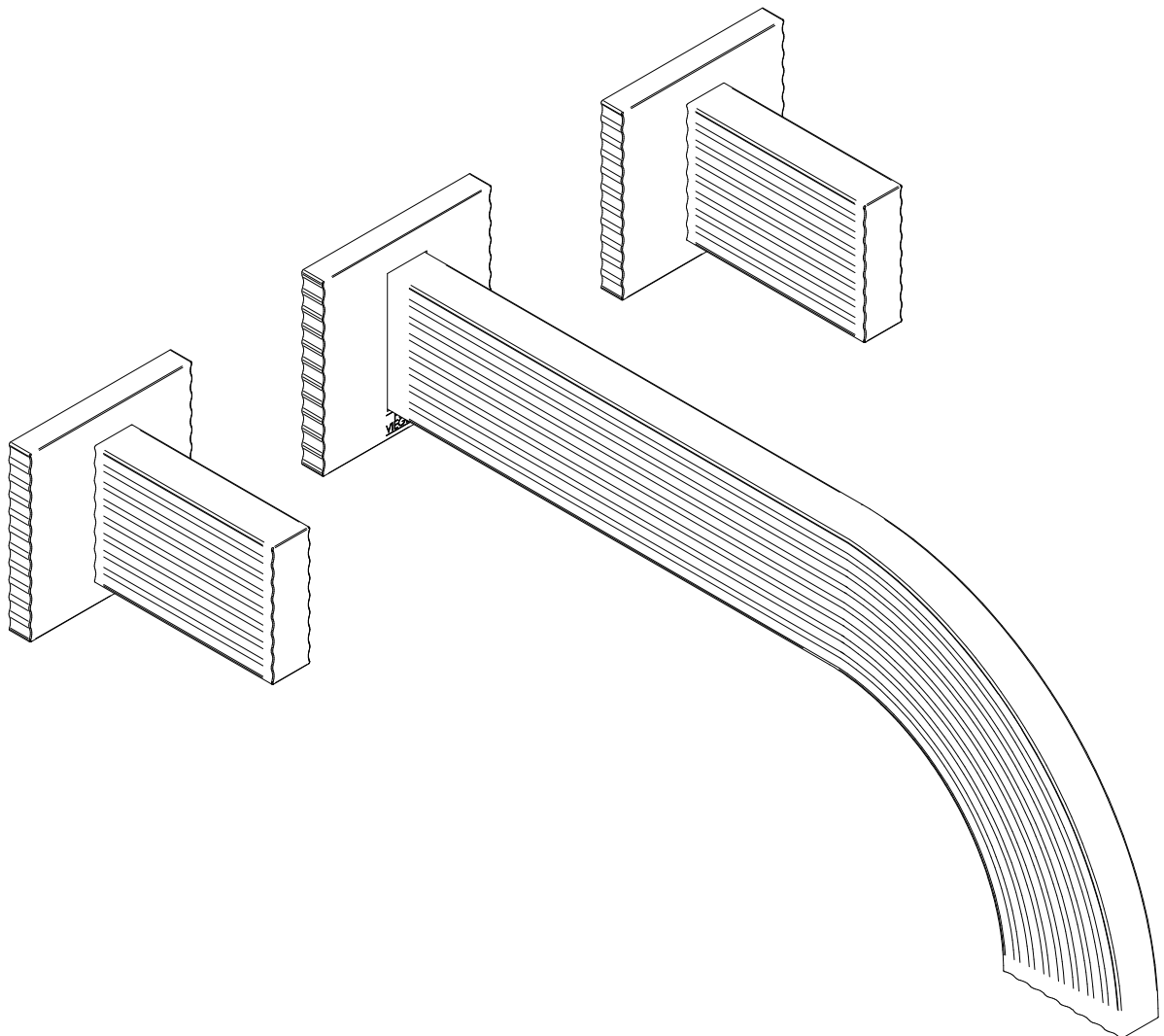

**Required installation tools / Herramientas necesarias para la instalación**

Provided / Provistas

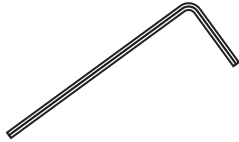

Allen wrench  
Llave Allen

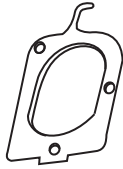

Aerator tool  
Herramienta para aireador

Not Provided / No Provistas

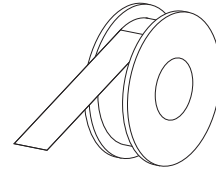

Teflon tape  
Cinta de Teflón

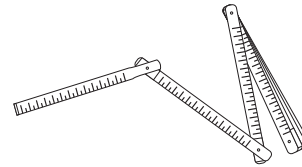

Ruler  
Regla

Hacksaw  
Sierra

# Exploded view / Vista explotada

## FI203.BASE

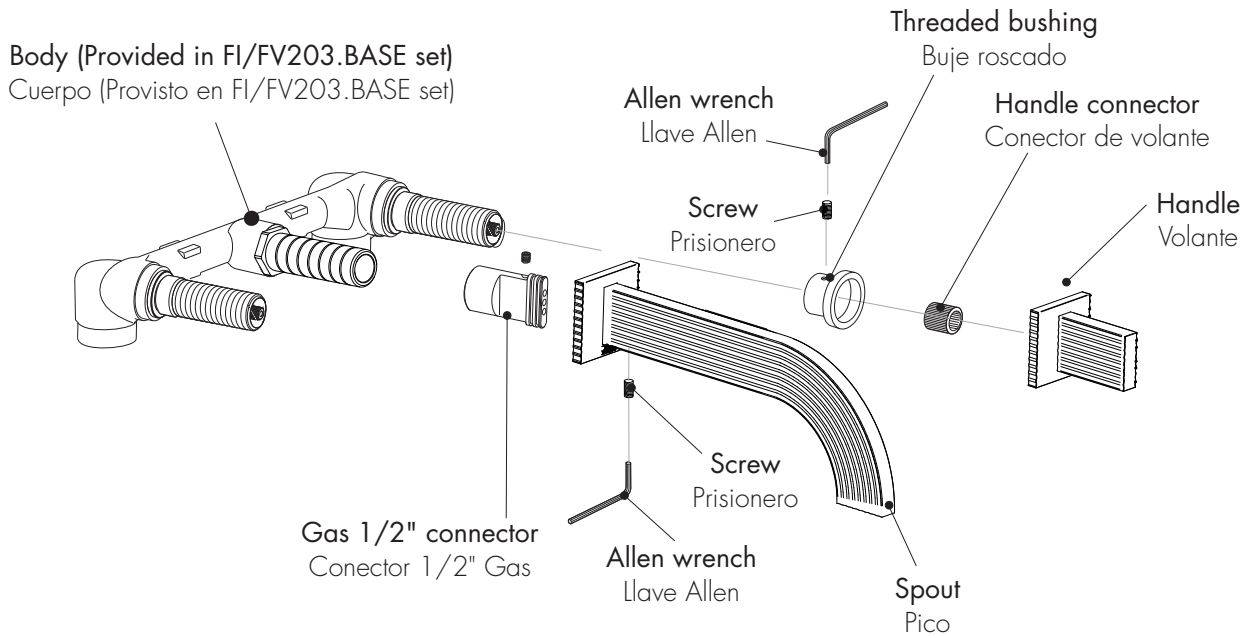

## Measures / Medidas

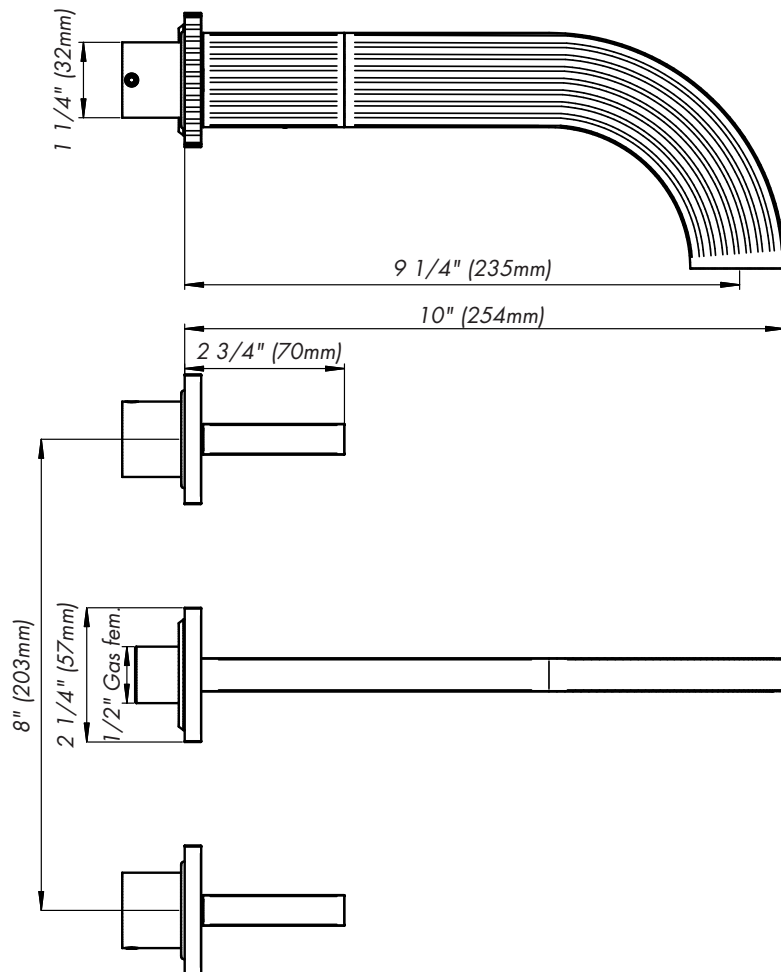

# Installation / Instalación

## Handle installation/Instalación del volante

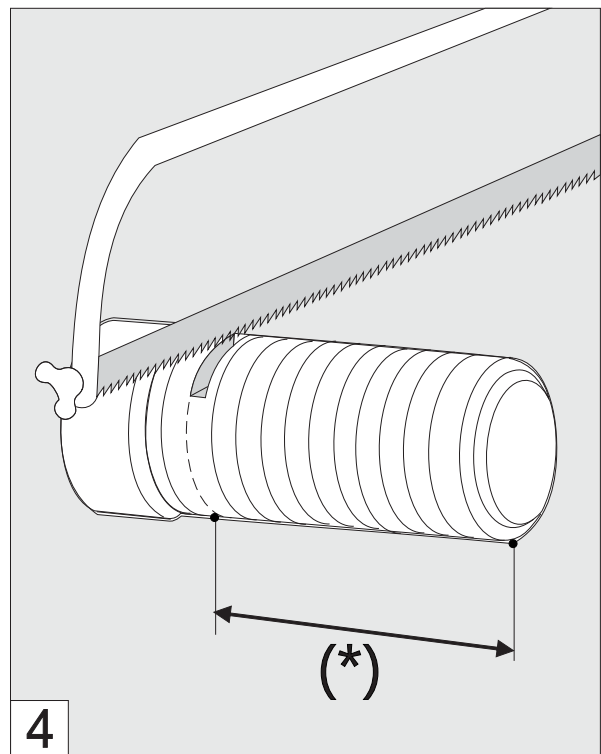
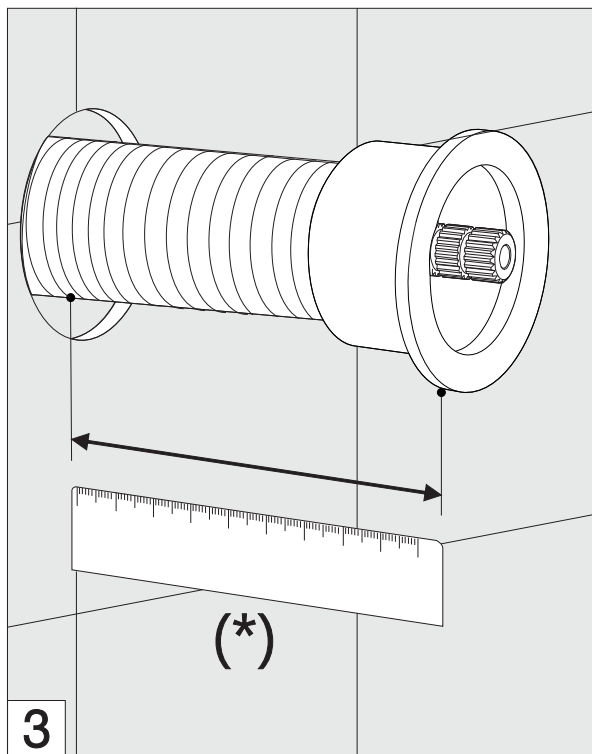
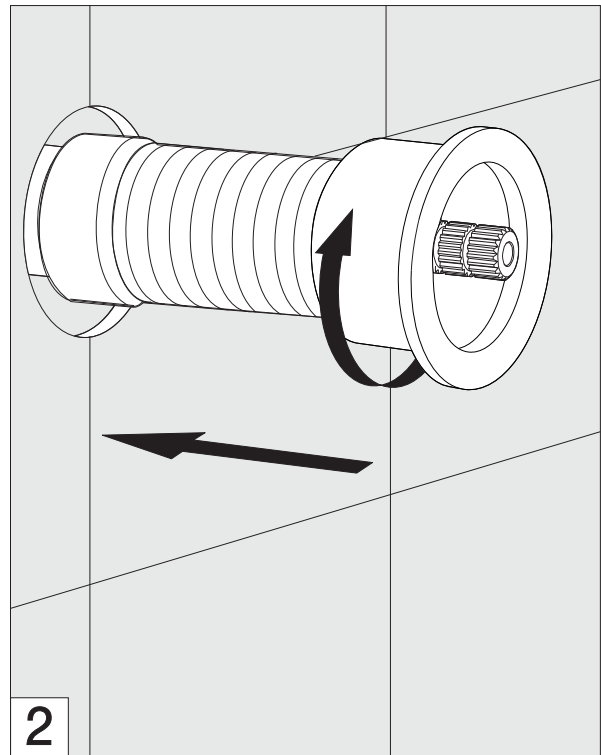
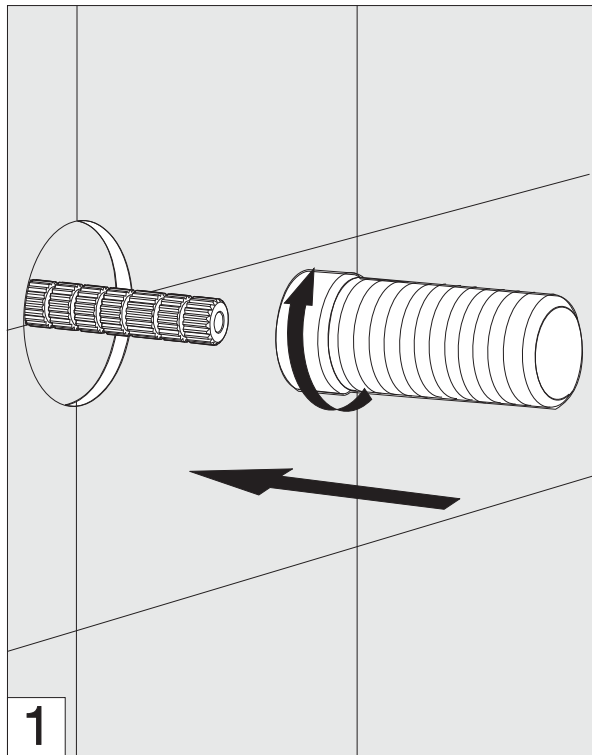

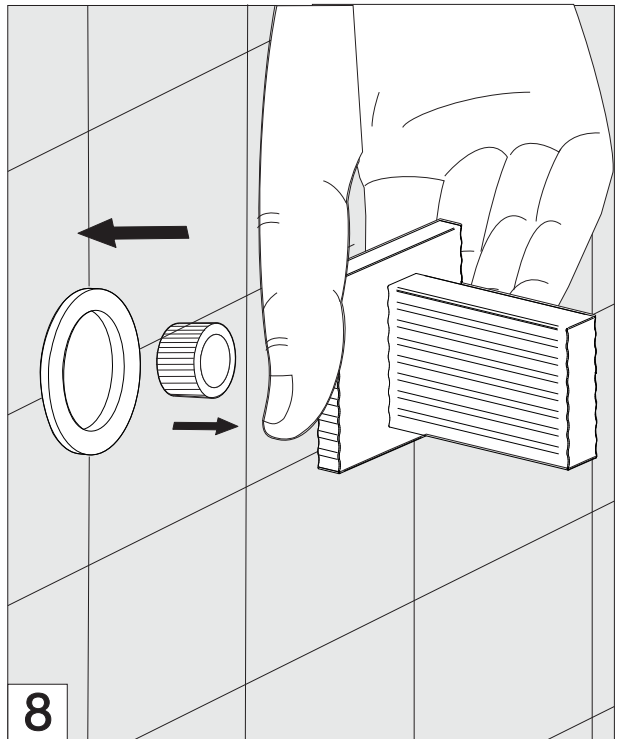
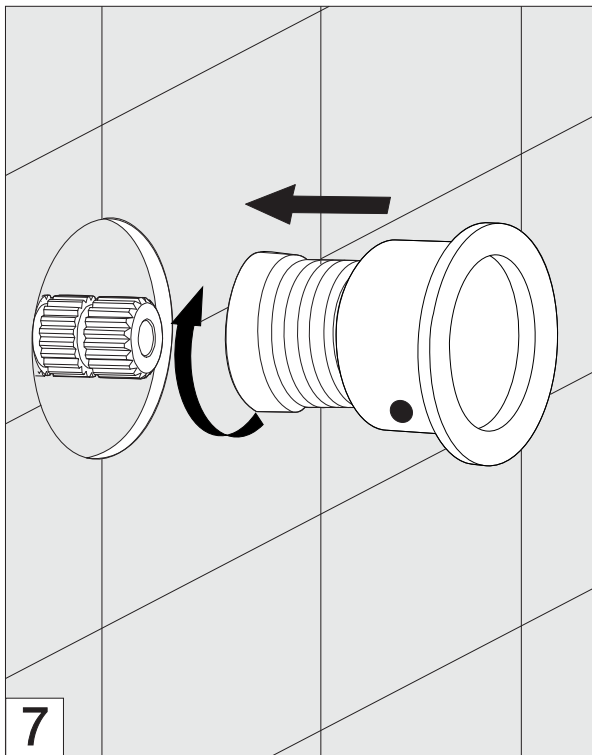
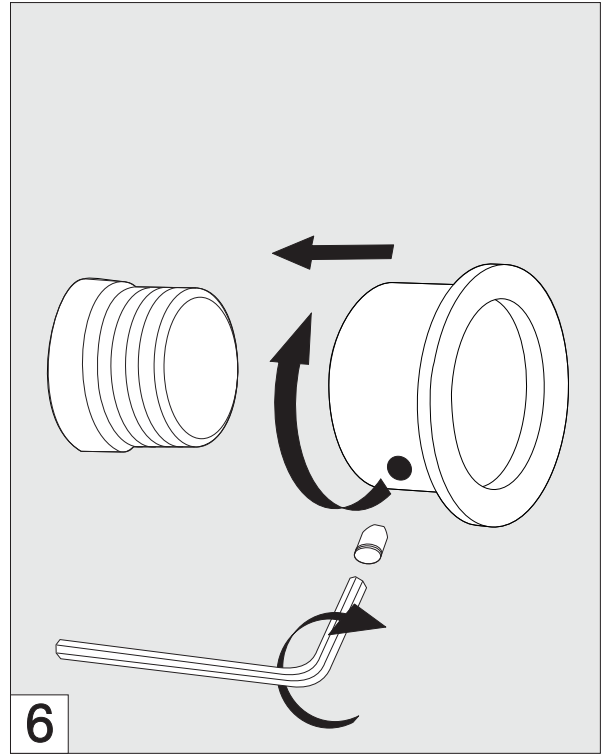
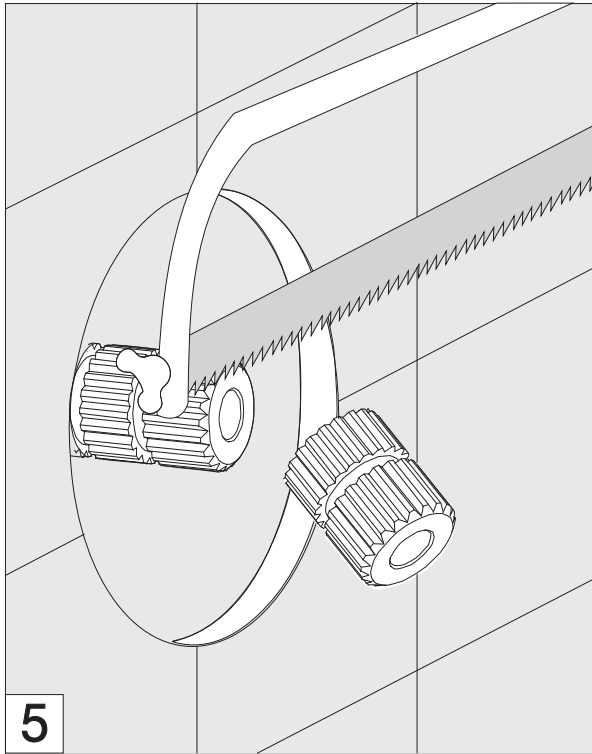

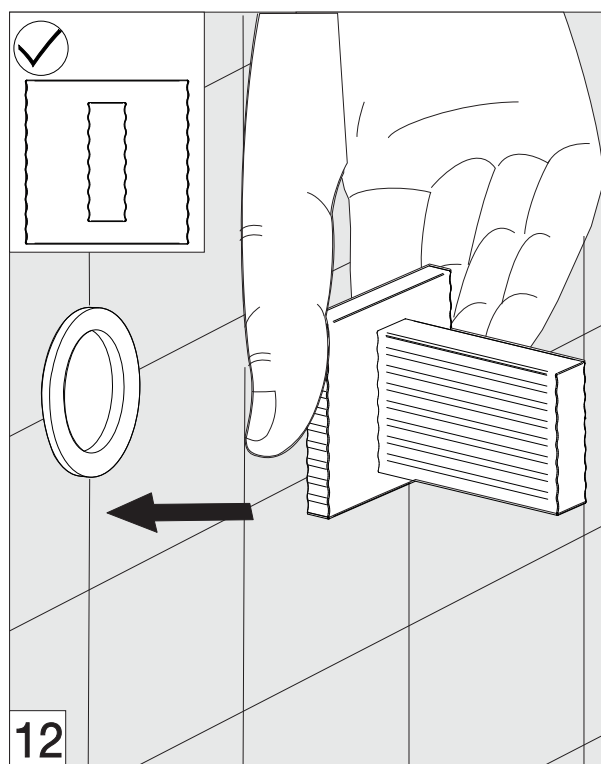
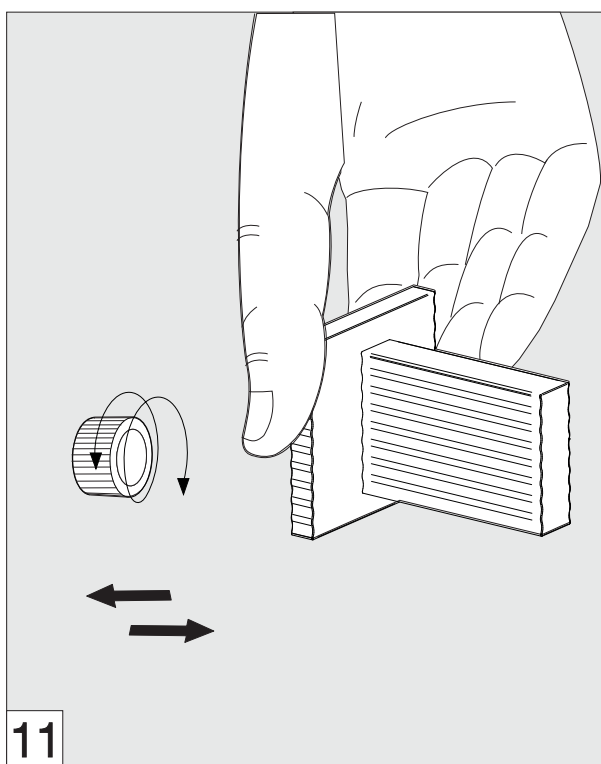
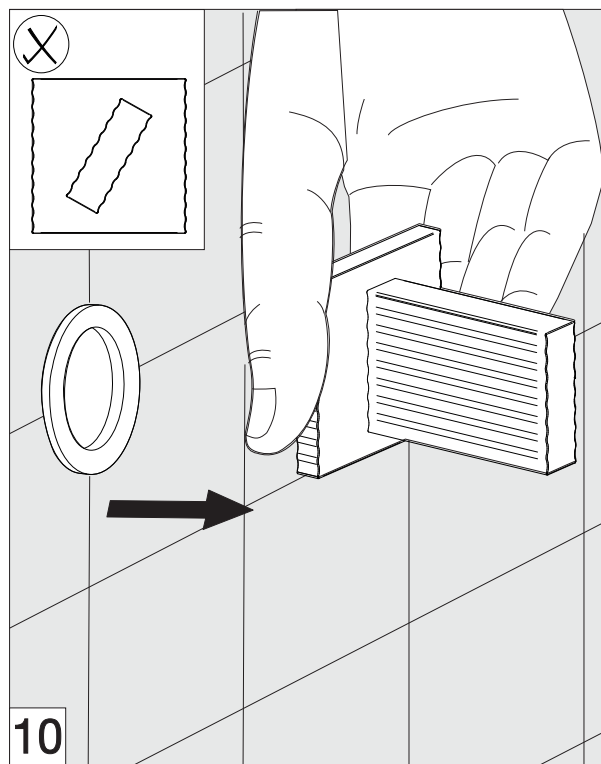
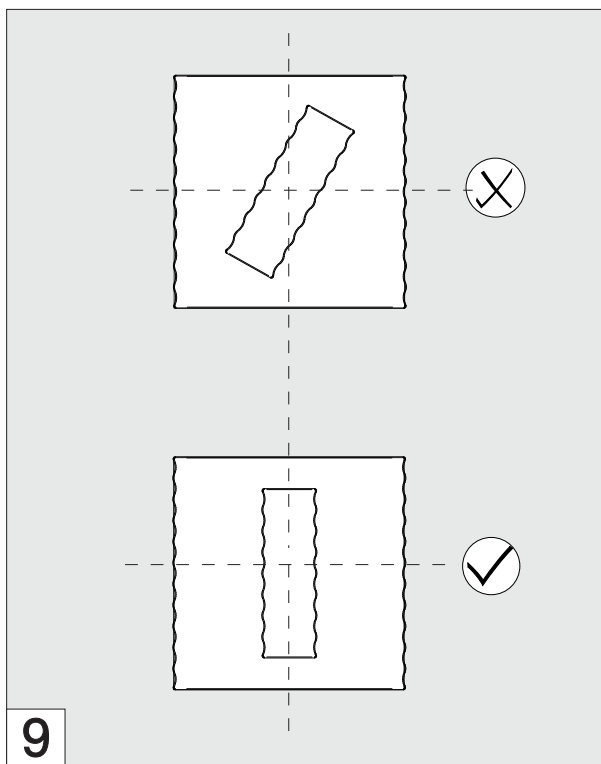

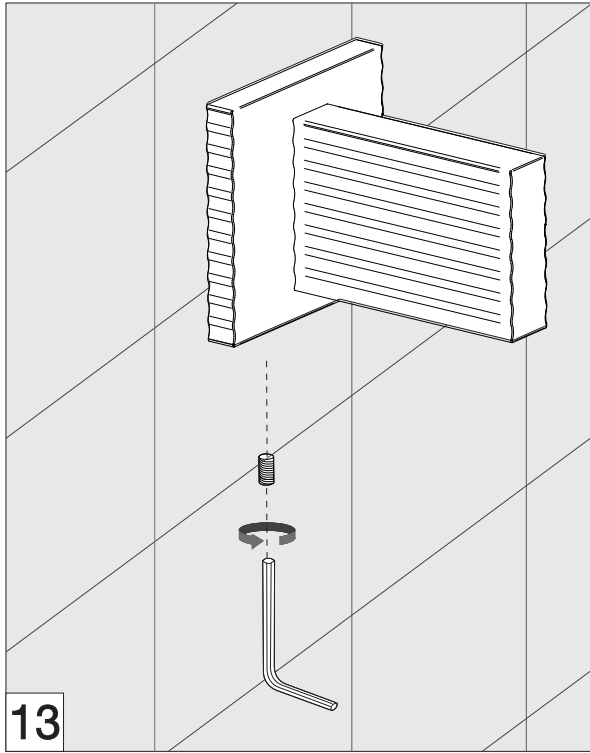

# Installation / Instalación

## Spout installation/Instalación del pico

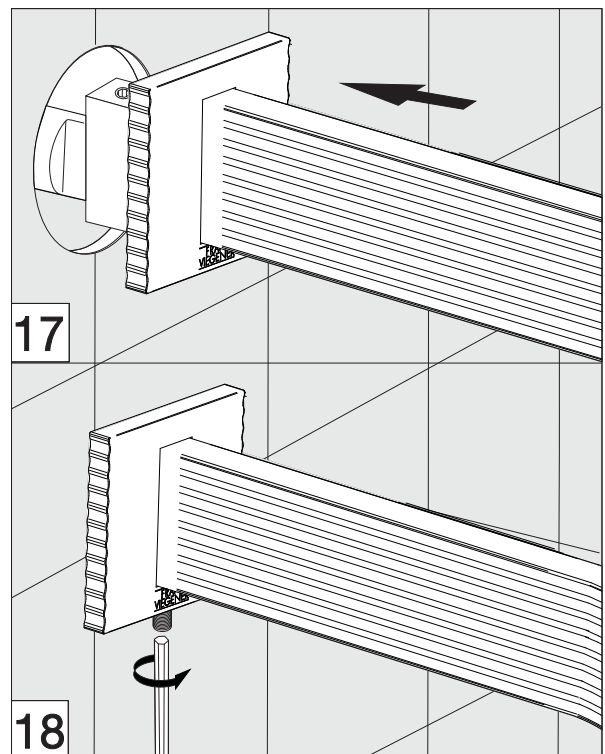
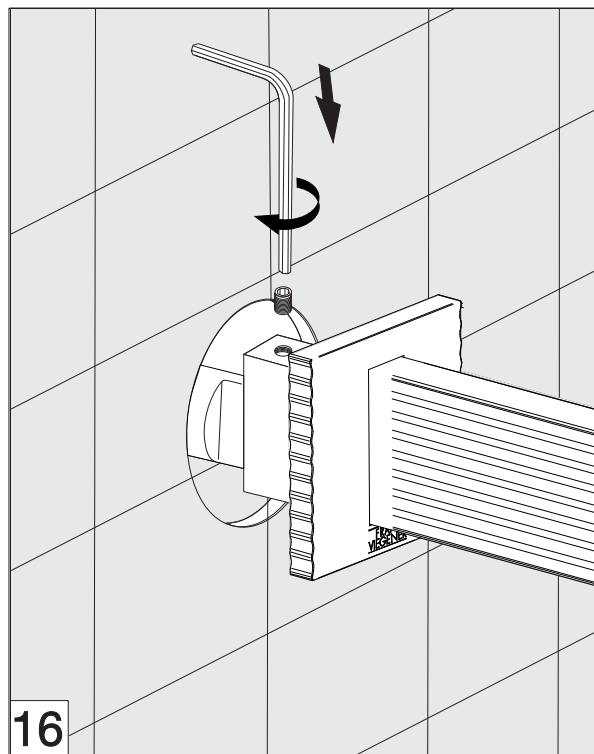
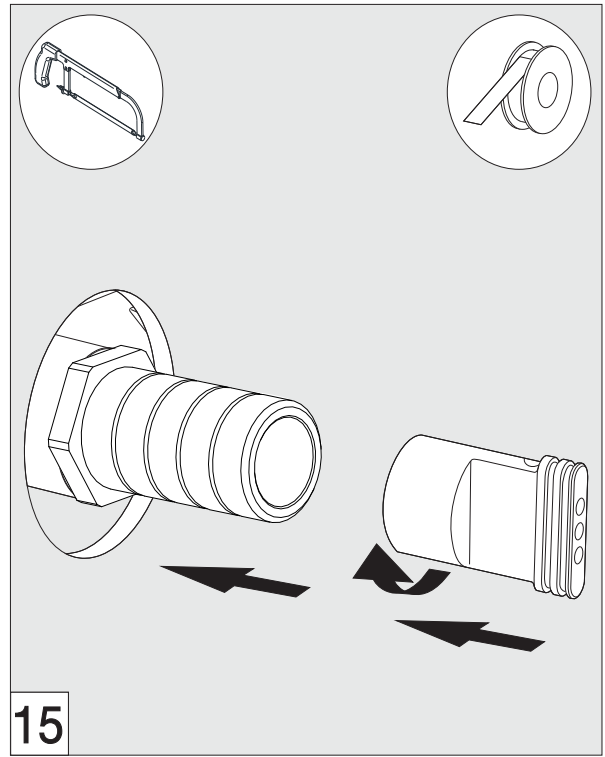
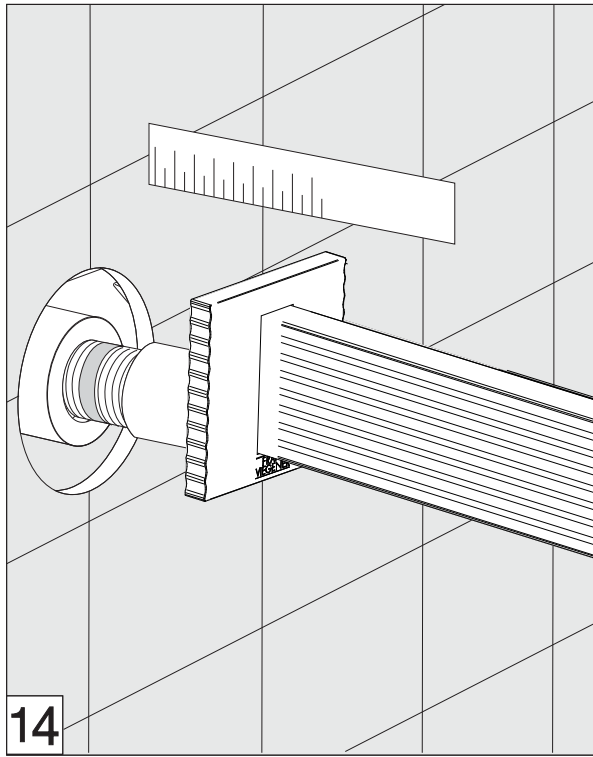









## Aerator cleaning / Limpieza de aireador

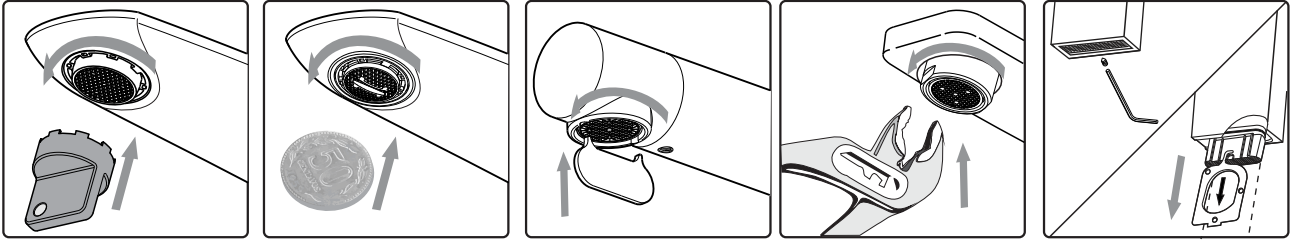

Place the corresponding tool according to the type of aerator you have and remove it. Wash it under a stream of water. If there is any sediment, place it in a glass of vinegar during the night. Put it back the next day.

Coloque la herramienta correspondiente según el tipo de aireador y remuevalo del pico. Lávelo bajo un chorro de agua. Si esta tapado colóquelo en un vaso de vinagre durante la noche. Al día siguiente vuelva a armarlo.



**Attention! Do not use sharp objects to unblock the aerator**  
**¡Atención! NO intente destapar el aireador utilizando objetos punzantes que puedan dañarlo**

**WARRANTY:** For more information please visit <https://franzviegner.com/warranty/>



FRANZ VIEGENER Customer Service Department (800) 446-9700

Phone 847-244-3837 / Fax 847-249-4049 - [info@franzviegner.com](mailto:info@franzviegner.com)

4000 Porett Drive - Gurnee, IL, 60031-USA.

Follow us on social media!



Scan the code to get more information about this line.

[www.franzviegner.com](http://www.franzviegner.com)