

FISH MATE[®]



Innovative Products for Ponds



Bell



1200 (Ref. 390*), 1500 (Ref. 391) & 1800 (Ref. 392) * Model varies from image shown

- Ideal for fountains and small ponds
- Includes fountain set with 4 options
- Low running costs
- 3 year guarantee
- Pond-life friendly

- 1 Single control knob adjusts flow to fountain and waterfall/filter
- 2 May be connected to filter or waterfall using 12mm (1/2") or 19mm (3/4") hose
- 3 Ceramic shaft bearings and superior rotor design for long service life
- 4 Fully encapsulated electrical parts for safety
- 5 High efficiency pump turbine ensures low running costs
- 6 Filter foam ensures minimum fountain maintenance



Column



2000 (Ref. 447), 3000 (Ref. 448) & 4000 (Ref. 449)

- Anti-clog filter design
- Includes fountain set with 4 options
- Low running costs
- 3 year guarantee
- Pond-life friendly

- 1 Single control knob adjusts flow to fountain and waterfall/filter
- 2 May be connected to filter or waterfall using 12mm (1/2"), 19mm (3/4") or 25mm (1") hose
- 3 Ceramic shaft bearings and superior rotor design for long service life
- 4 Fully encapsulated electrical parts for safety
- 5 High efficiency pump turbine ensures low running costs
- 6 Strainer filter less prone to blockage and easier to clean than conventional foam filters



Plume



5000 (Ref. 377), 7000 (Ref. 378) & 9000 (Ref. 379)

- Very low running costs
- Includes fountain set with 4 options
- Anti-clog design
- 3 year guarantee
- Solids-handling capability to 8mm (3/8")

- 1 High performance pump with innovative, energy saving electronics
- 2 Ceramic shaft bearings and superior rotor design for long service life
- 3 Fully encapsulated electrical parts for safety
- 4 High efficiency turbine handles solids to 8mm (3/8") and ensures low running costs
- 5 Strainer filter less prone to blockage and easier to clean than conventional foam filters
- 6 Handle for easy placement/retrieval from pond
- 7 Single control knob adjusts flow to fountain and waterfall/filter



Tiered



18000 (Ref. 364)

- Very low running costs
- Solids-handling capability to 5mm (3/16")
- Anti-clog design
- 3 year guarantee
- Super-quiet operation

- 1 High performance pump with innovative, energy saving electronics
- 2 May be connected to filter or waterfall using 25mm (1"), 32mm (1 1/4"), 38mm (1 1/2") or 50mm (2") hose
- 3 Ceramic shaft bearings and superior rotor design for long service life
- 4 Fully encapsulated electrical parts for safety
- 5 High efficiency turbine handles solids to 5mm (3/16") and ensures low running costs
- 6 Strainer filter less prone to blockage and easier to clean than conventional foam filters
- 7 Handle for easy placement/retrieval from pond

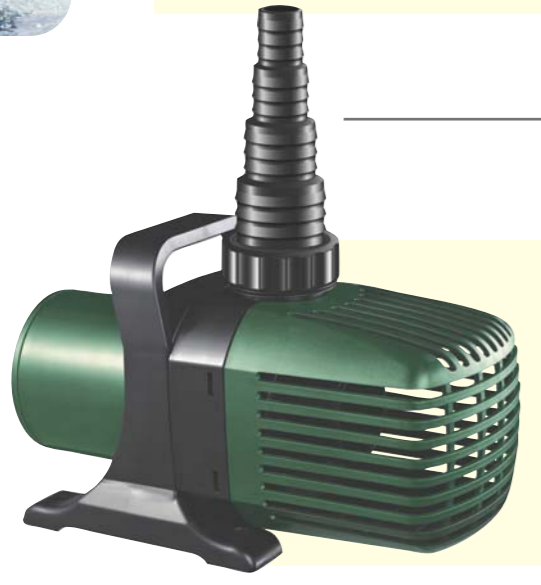

Ref. 344

Ref. 390

Ref. 391 392

Ref. 447 448 449

Ref. 377 378 379

Ref. 364

	Model	700	1200	1500	1800	2000	3000	4000	5000	7000	9000	18000
	Ref.	344	390	391	392	447	448	449	377	378	379	364
Performance	Max. flowrate	700L/h (154GPH)	1200L/h (265GPH)	1500L/h (330GPH)	1800L/h (400GPH)	2000L/h (440GPH)	3000L/h (660GPH)	4000L/h (880GPH)	5500L/h (1210GPH)	7000L/h (1540GPH)	8500L/h (1870GPH)	18000L/h (3960GPH)
	Max. Head	1.2m (4' 0")	1.7m (5' 7")	1.7m (5' 7")	1.7m (5' 7")	2.5m (8' 2")	2.8m (9' 2")	2.9m (9' 6")	4.0m (13' 2")	4.5m (14' 9")	5.0m (16' 5")	6.5m (21' 4")
	Power Consumption (Wattage)	9	11	25	25	25	44	47	50	70	85	155
Accessories	Outlet Size	12mm (1/2")	12mm, 19mm (1/2", 3/4")	12mm, 19mm (1/2", 3/4")		12mm, 19mm, 25mm (1/2", 3/4", 1")			19mm, 25mm, 32mm (3/4", 1", 1 1/4")			25mm, 32mm 38mm, 50mm (1", 1 1/4", 1 1/2", 2")
	Fountain Set (No. of options)	4	4	4		4			4			-
Fountains	Bell Fountain max. Diameter	0.2m (8")	0.4m (1' 4")	0.5m (1' 8")	0.5m (1' 8")	0.6m (2' 0")	0.6m (2' 0")	0.6m (2' 0")	0.8m (2' 8")	0.8m (2' 8")	0.8m (2' 8")	-
	Column Fountain max. Diameter x Height	0.6m x 0.6m (2' 0" x 2' 0")	0.2m x 0.9m (8" x 2' 11")	0.3m x 1.1m (1' 0" x 3' 7")	0.3m x 1.1m (1' 0" x 3' 7")	0.6m x 1.75m (2' 0" x 5' 6")	0.6m x 1.75m (2' 0" x 5' 6")	0.6m x 1.75m (2' 0" x 5' 6")	0.8m x 1.9m (2' 8" x 6' 3")	0.8m x 1.9m (2' 8" x 6' 3")	0.8m x 1.9m (2' 8" x 6' 3")	-
	Plume Fountain max. Diameter x Height	0.15m x 0.15m (6" x 6")	0.1m x 0.5m (4" x 1' 8")	0.1m x 0.6m (4" x 2' 0")	0.1m x 0.6m (4" x 2' 0")	0.2m x 1.25m (8" x 4' 1")	0.2m x 1.25m (8" x 4' 1")	0.2m x 1.25m (8" x 4' 1")	0.4m x 1.3m (1' 4" x 4' 3")	0.4m x 1.3m (1' 4" x 4' 3")	0.4m x 1.3m (1' 4" x 4' 3")	-
	Tiered Fountain max. Diameter x Height	0.6m x 0.6m (2' 0" x 2' 0")	0.3m x 1.0m (1' 0" x 3' 3")	0.4m x 1.2m (1' 4" x 3' 11")	0.4m x 1.2m (1' 4" x 3' 11")	0.8m x 1.75m (2' 8" x 5' 6")	0.8m x 1.75m (2' 8" x 5' 6")	0.8m x 1.75m (2' 8" x 5' 6")	1.0m x 2.0m (3' 3" x 6' 7")	1.0m x 2.0m (3' 3" x 6' 7")	1.0m x 2.0m (3' 3" x 6' 7")	-
	Outlet with Flow Adjuster	✓	✓	✓		✓			✓			-
Vertical & Horizontal Outlet	-	✓	✓		✓			✓			-	
Motor and Shaft/Bearings	Power Cable Length	10m (33')	10m (33')	10m (33')		10m (33')			10m (33')			10m (33')
	Ceramic Bearings	✓	✓	✓		✓			✓			✓
Solids-Handling	Pond-life Friendly Strainer Filter	✓	✓	✓		✓			-			-
	Optional Fountain Filter Foam	✓	✓	✓		-			-			-
	Anti-Clog Open Impeller	✓	✓	✓		✓			✓			✓
	Solids-Handling	-	-	-		-			8mm (3/8")			5mm (3/16")
Dimensions	Length x Width x Height	143mm x 54mm x 75mm (5 5/8" x 2 1/8" x 3")	131mm x 72mm x 81mm (5 1/8" x 2 7/8" x 3 1/8")	160mm x 65mm x 90mm (6 1/4" x 2 5/8" x 3 1/2")		239mm x 145mm x 133mm (9 3/8" x 5 3/4" x 5 1/4")			245mm x 121mm x 131mm (9 5/8" x 4 3/4" x 5 1/4")			325mm x 175mm x 195mm (12 3/4" x 7 1/8" x 6 1/8")
	Fully Encapsulated Electrical Parts	✓	✓	✓		✓			✓			✓
Safety	Thermal Cutout	-	✓	✓		✓			✓			✓

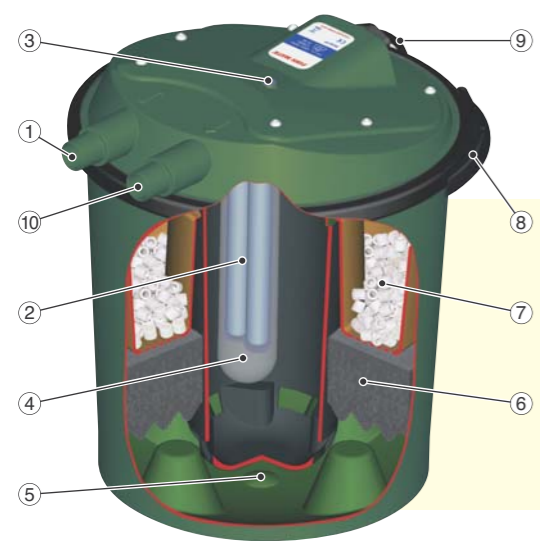

5000 P-UV (Ref. 265)

- Combined UV and biological filtration for crystal clear purified water
- Easy to maintain
- Easy installation above or below ground level
- Includes **SUPRA+** bio media
- 3 year guarantee

- Multisized inlet: 19mm (3/4") or 25mm (1")
- Easy to replace UV lamp
- UV lamp on indicator
- UV chamber
- Settlement chamber
- Profiled filter foam for mechanical filtration (supplied)
- Fish Mate **SUPRA+** biological filter media (supplied)
- Lid secured by single clamp ring allows easy access for filter maintenance
- Fitted with 5m (16') power cable
- Outlet may be extended with 19mm (3/4") or 25mm (1") hose if required

10000 P-UV (Ref. 266), 15000 P-UV (Ref. 267) & 15000 P-BIO (Ref. 271)

- Powerclenz Automatic Cleaning System
- Combined UV and biological filtration for crystal clear purified water (Ref. 266, 267 only)
- Easy to maintain
- Easy installation above or below ground level
- Includes **SUPRA+** bio media
- 3 year guarantee

- Multisized inlet: 19mm (3/4") or 25mm (1")
- Easy to replace UV lamp (Ref. 266, 267 only)
- UV lamp on indicator (Ref. 266, 267 only)
- UV chamber (Ref. 266, 267 only)
- Settlement chamber
- Profiled filter foam for mechanical filtration (supplied)
- Fish Mate **SUPRA+** biological filter media (supplied)
- Lid secured by single clamp ring allows easy access for filter maintenance
- Fitted with 5m (16') power cable (Ref. 266, 267 only)
- Outlet may be extended with 19mm (3/4"), 25mm (1") or 32mm (1 1/4") hose if required
- P** Powerclenz control knob for automatic cleaning of foam filter elements
- S** Sludge outlet - may be extended with 3/4" or 1" hose if required

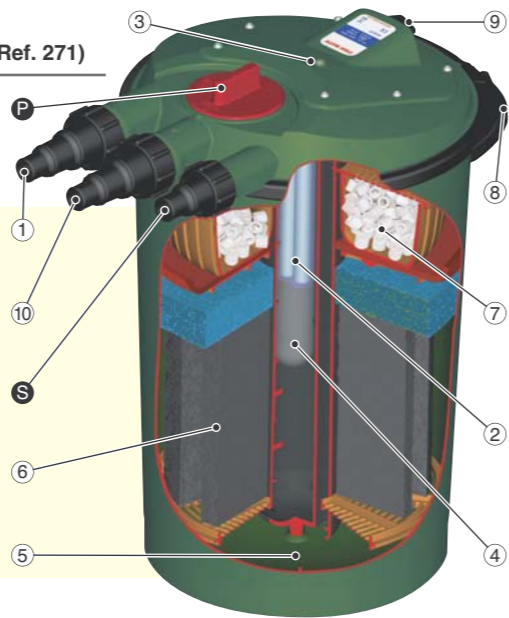

30000 P-UV (Ref. 320) & 45000 P-UV (Ref. 321)

- Powerclenz Automatic Cleaning System
- Combined UV and biological filtration for crystal clear purified water
- Easy to maintain
- Easy installation above or below ground level
- Includes **SUPRA+** bio media
- 3 year guarantee

- Multisized inlet: 32mm (1 1/4") or 38mm (1 1/2")
- Easy to replace UV lamp
- UV lamp on indicator
- UV chamber
- Primary mechanical filtration brush / settlement chamber
- Multi-stage profiled filter foams for secondary mechanical filtration (supplied)
- Fish Mate **SUPRA+** biological filter media (supplied)
- Lid secured by single clamp ring allows easy access for filter maintenance
- Fitted with 5m (16') power cable
- Outlet may be extended with 32mm (1 1/4") or 38mm (1 1/2") hose if required
- P** Powerclenz control knob for automatic cleaning of foam filter elements
- S** Sludge outlet - may be extended with 19mm (3/4"), 25mm (1") or 32mm (1 1/4") hose if required

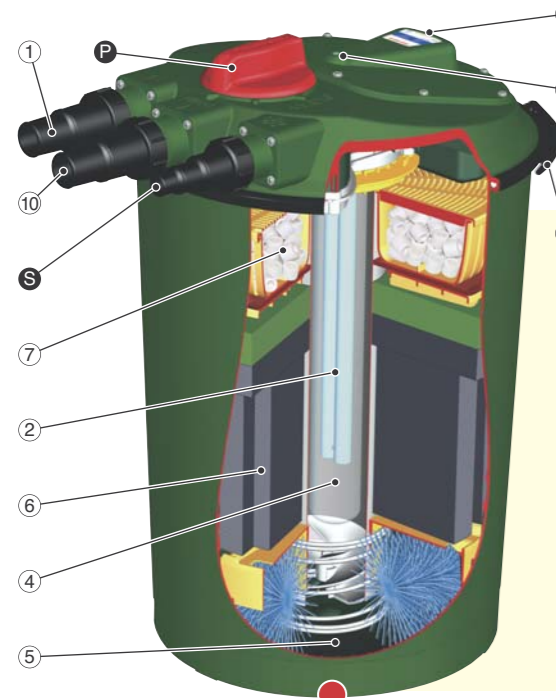

Powerclenz Automatic Cleaning System

The patented Powerclenz automatic cleaning system is unique in that by a simple twist of a knob, the filter automatically cleans itself.

POSITION "RUN"
Incoming water undergoes a 3-stage purification process

POSITION "CLEAN"
Simply turn the knob and the foam will be squeezed by up to 1000lb force through water pressure forcing out pond sludge.

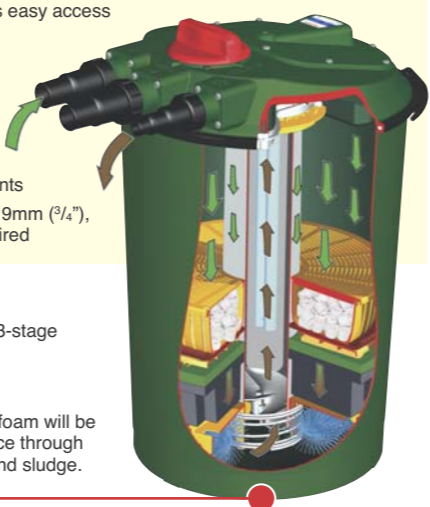

	Model Ref.	5000 P-UV 265	10000 P-UV 266	15000 P-UV 267	15000 P-BIO 271	30000 P-UV 320	45000 P-UV 321	2500 G-UV 226	5000 G-BIO 228	5000 S-UV 375
UV		9	9	13	-	24	36	8	-	11
Max. flow		2500 LPH (500 GPH)	5000 LPH (1000 GPH)	7500 LPH (1500 GPH)	7500 LPH (1500 GPH)	15000 LPH (3000 GPH)	15000 LPH (3000 GPH)	1250 LPH (250 GPH)	2500 LPH (500 GPH)	1500 LPH (300 GPH)
Maximum Pond Size										
		5000 Litres (1000 Gallons)	10000 Litres (2000 Gallons)	15000 Litres (3000 Gallons)	15000 Litres (3000 Gallons)	30000 Litres (6000 Gallons)	45000 Litres (9000 Gallons)	2500 Litres (500 Gallons)	5000 Litres (1000 Gallons)	1000 Litres (200 Gallons)
		2500 Litres (500 Gallons)	5000 Litres (1000 Gallons)	7500 Litres (1500 Gallons)	7500 Litres (1500 Gallons)	15000 Litres (3000 Gallons)	22500 Litres (4500 Gallons)	1250 Litres (250 Gallons)	2500 Litres (500 Gallons)	500 Litres (100 Gallons)
		2500 Litres (500 Gallons)	5000 Litres (1000 Gallons)	7500 Litres (1500 Gallons)	7500 Litres (1500 Gallons)	15000 Litres (3000 Gallons)	22500 Litres (4500 Gallons)	1250 Litres (250 Gallons)	2500 Litres (500 Gallons)	-
		1250 Litres (250 Gallons)	2500 Litres (500 Gallons)	3750 Litres (750 Gallons)	3750 Litres (750 Gallons)	7500 Litres (1500 Gallons)	11250 Litres (2250 Gallons)	625 Litres (125 Gallons)	1250 Litres (250 Gallons)	-
Installation	Buriable	✓	✓	✓	✓	✓	✓	-	-	-
	Submersible	-	-	-	-	-	-	-	-	✓
	Inlet Size Ø	19mm, 25mm (3/4", 1")	19mm, 25mm, 32mm (3/4", 1", 1 1/4")			32mm, 38mm (1 1/4", 1 1/2")		19mm, 25mm (3/4", 1")	19mm, 25mm (3/4", 1")	-
	Outlet Size Ø	19mm, 25mm (3/4", 1")	19mm, 25mm, 32mm (3/4", 1", 1 1/4")			32mm, 38mm (1 1/4", 1 1/2")		32mm x 2 (1 1/4")	32mm x 2 (1 1/4")	12mm, 19mm, 25mm (1/2", 3/4", 1")
	Powerclenz Automatic Cleaning System	-	✓	✓	✓	✓	✓	-	-	-
Biological Filtration	Bio Media	SUPRA+	SUPRA+	SUPRA+	SUPRA+	SUPRA+	SUPRA+	SUPRA+	SUPRA+	✓
	Removable tray	✓	✓	✓	✓	✓	✓	-	-	-
	Power cable length	5m (16')	5m (16')	-	-	5m (16')	5m (16')	-	-	10m (33')
Dimensions	Length x Width x Height	270mm x 250mm x 280mm (10 3/4" x 10" x 11")	390mm x 280mm x 430mm (15 1/2" x 11" x 17")			445mm x 400mm x 625mm (17 1/2" x 15 3/4" x 24 1/2")		381mm x 249mm x 180mm (15" x 10" x 7")	381mm x 249mm x 122mm (15" x 10" x 5")	371mm x 265mm x 130mm (14 3/8" x 10 1/2" x 5 1/8")
Guarantee	Clear water	✓	✓	-	✓	✓	✓	-	-	✓
	Filter	3 Years	3 Years	3 Years	3 Years	3 Years	3 Years	3 Years	3 Years	3 Years
	UV lamp	6 Months	6 Months	-	6 Months	6 Months	6 Months	-	-	6 Months

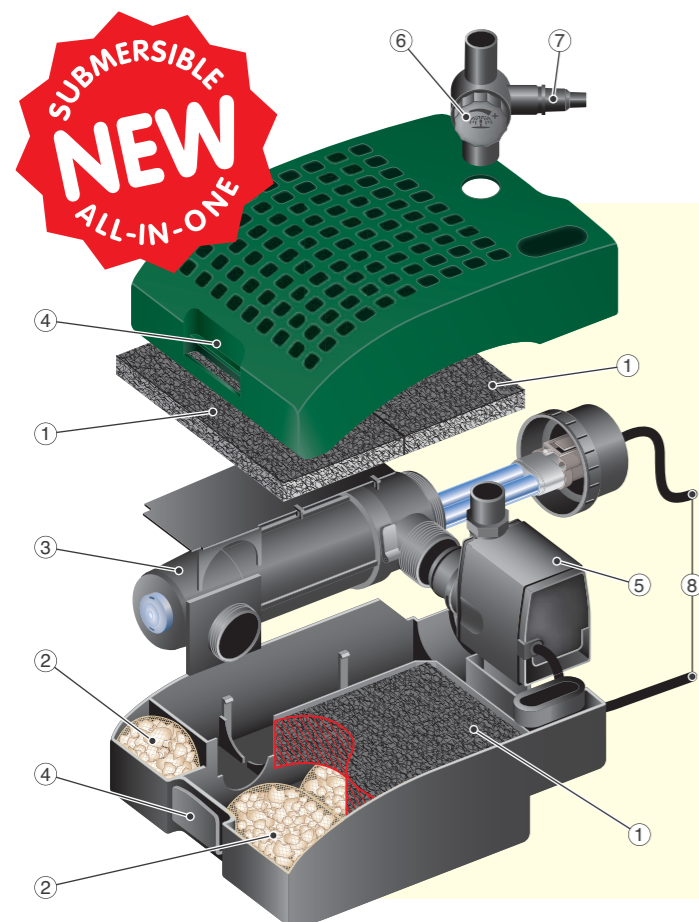

5000 S-UV (Ref. 375)

- The all-in-one solution for crystal clear, healthy pond water
- UV, biological and mechanical filtration with integrated pump
- Easy to install and maintain
- Includes fountain set with 4 options
- 3 year guarantee

- 3 x Filter sponges (supplied) provide primary filtration, trapping large particles.
- Includes biological filter medium in net bags for easy removal and cleaning.
- Low voltage U.V. chamber eliminates algae that cause green water.
- Simple snap-lock lid design allows easy access for filter foam maintenance and U.V. lamp replacement.
- High efficiency pump turbine with ceramic shaft bearings ensures long service life and low running costs.
- Single control knob adjusts flow to fountain and waterfall or feature.
- May be connected to waterfall or feature with 12mm (1/2"), 19mm (3/4") or 25mm (1") hose
- Supplied with fitted power cables and low voltage UV transformer.

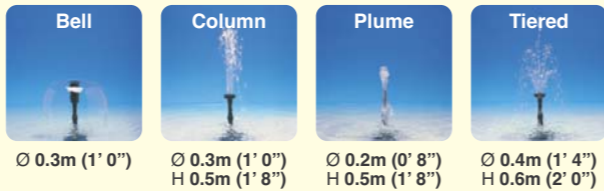

2500 G-UV (Ref. 226C)

- Combined UV and biological filtration for crystal clear purified water
- Flip up lid for easy maintenance
- Frostproof quartzless UV chamber
- Includes **SUPRA+** bio media
- Colored green to blend in with natural surroundings
- 3 year guarantee

- Multisized inlet: 19mm (3/4") or 25mm (1")
- Easy to replace UV tube
- High efficiency U.V. reflector
- Large capacity, slow flow U.V. chamber ensures efficient algae clumping and acts as primary settlement chamber
- Flow gauge enables you to easily ensure the correct flow through your filter
- Profiled filter sponge for mechanical filtration (supplied)
- Fish Mate **SUPRA+** biological filter media (supplied)
- Hinged lid allows easy access
- 1 or 2 outlets. May be extended with 38mm (1 1/2") hose if required
- Fitted with 5m (16') power cable

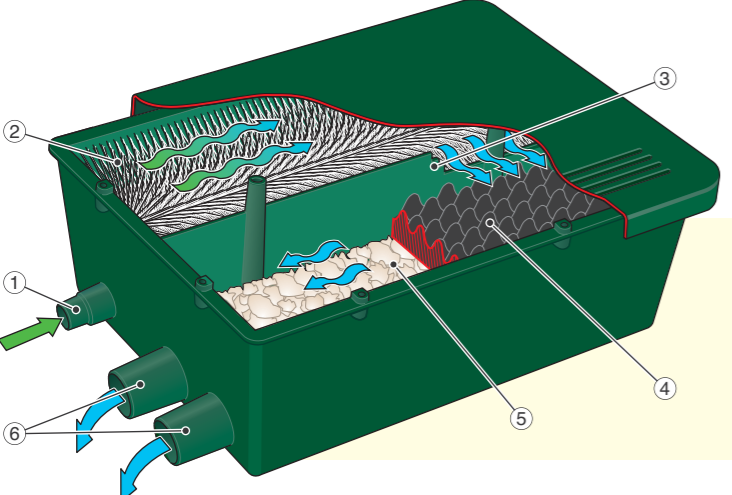
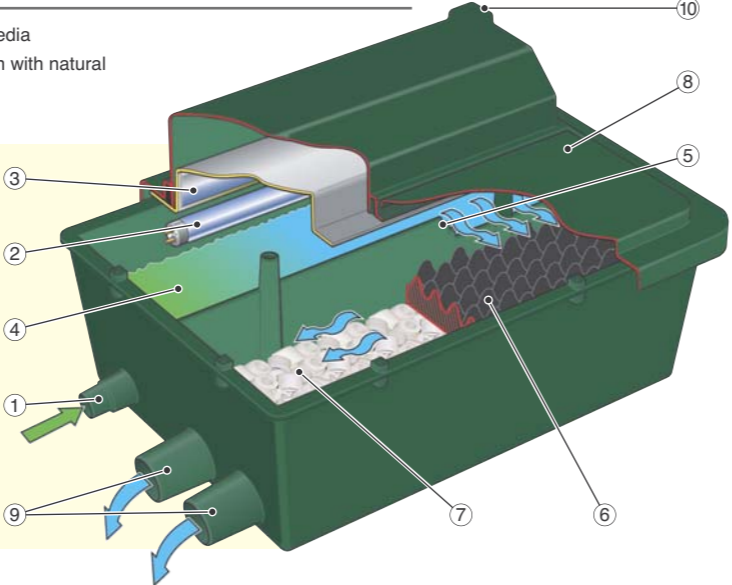

5000 G-BIO (Ref. 228)

- Powerful 3 stage mechanical and biological filtration for optimal water quality and healthier fish
- Easy filter maintenance
- Designed to blend with natural surroundings
- Includes **SUPRA+** bio media
- 3 year guarantee

- Multisized inlet: 19mm (3/4") or 25mm (1")
- Primary mechanical filtration brush / settlement chamber
- Flow gauge enables you to easily ensure the correct flow through your filter
- Profiled filter sponge for mechanical filtration (supplied)
- Fish Mate **SUPRA+** biological filter media (supplied)
- 1 or 2 outlets. May be extended with 38mm (1 1/2") hose if required



P7000 POND FISH FEEDER (Ref. 348)

The Fish Mate P7000 Pond Fish Feeder is suited to larger ponds for use with pellet or 'stick' food. Variable feed sizes are dispensed at programmed times or on demand at the touch of a button.

- 7 Litre (6.5lbs) capacity dry food hopper.
- Easy to use LCD control with approximately 6 to 9 months battery life in continuous use
- Unique feed mechanism ensures accurate and consistent feed sizes from 15ml (3 teaspoons) upwards
- Weather-resistant
- Can be fastened to a secure base for increased stability
- Suitable for most popular food sticks and pellets
- Dimensions: L 210mm (8 1/4") x W 210mm (8 1/4") x H 350mm (13 3/4")

P21 POND FISH FEEDER (Ref. 211)

For smaller ponds and large aquariums, the P21 will dispense food daily over a period of several hours for approx 21 days. The fully weatherproofed P21 may be pole-mounted at waters edge or suspended over the water.

- Reliable and accurate quartz timer
- Over 1 year's continuous use from 1 x AA battery
- Battery condition indicator
- Food capacity of approximately 21 daily meals
- Food served over several hours - keeps fish active and reduces danger of overfeeding
- Adjustable feed quantity and timing for all fish foods
- Easily suited to all ponds and large aquariums
- Dimensions: L 183mm (7 1/4") x W 90mm (3 1/2") x H 174mm (6 7/8")



F14 AQUARIUM FISH FEEDER (Ref. 207)

This versatile feeder may be mounted on the aquarium hood, on a condensation tray, or on the glass edge of the aquarium with the brackets provided.

- Reliable and accurate quartz timer
- Over 1 year's continuous use from 1 x AA battery
- Battery condition indicator
- Serves up to 14 individual meals while you are away
- Food served over several hours - keeps fish active and reduces danger of overfeeding
- Accurate feeding of all fish foods, including flake
- Easy to use timer provides from 1 to 4 meals per day
- Dimensions: L 139mm (5 1/2") x W 118mm (4 5/8") x H 39mm (1 1/2")



FISH MATE®

Pet Mate Ltd, established in 1986, is dedicated to providing customers well designed, innovative, high quality product at competitive pricing with a high level of customer service. To this end, all products under the **Fish Mate** brand are manufactured in compliance with the most demanding standards.



As a measure of success, **Pet Mate** now supplies distributors in 40 countries. Since 1991 distribution in the North American market has been handled by **Ani Mate** - a wholly owned operating division of **Pet Mate Ltd**.

Pet Mate Ltd.

Lyon Road, Hershaw, Surrey KT12 3PU England
Telephone +44 (0)1932 700 000
Fax +44 (0)1932 700 002

Ani Mate

104A Longview Drive, Conroe, Texas 77301 USA
Telephone (936) 760 4333
Fax (936) 760 4338

Email sales@pet-mate.com



All goods are subject to Pet Mate's standard terms and conditions of sale. As part of our commitment to continuous product improvement, we reserve the right to make design and manufacturing changes which may mean that products supplied differ in certain respects from those illustrated and specified in this catalogue.

www.pet-mate.com