

### IMPORTANT SAFETY INSTRUCTIONS

**WARNING - To guard against injury or death, basic safety precautions should be observed, including the following:**

### READ AND FOLLOW ALL SAFETY INSTRUCTIONS

- Register your purchase on-line at [www.pet-mate.com/uk](http://www.pet-mate.com/uk) (see guarantee overleaf).
- All electrical work must be carried out by a competent electrician.
- Check that the voltage label on the motor (H) (see Fig. 1) conforms with your supply voltage.
- The pump **MUST** be wired into an R.C.D./G.F.I. circuit breaker (maximum 30mA) and a 3 AMP (maximum) fuse. Ensure breaker is regularly tested in accordance with manufacturers instructions.
- Connection to the power supply should be made through a CE approved weatherproof outdoor socket or double pole switched enclosure with minimum 3mm (1/8") contact separation in all poles. If product is hard wired to electrical supply this must comply fully with the wiring regulations of the national and local electricity authority. The pump must be protected by a 3 AMP (maximum) fuse.
- This appliance must be earthed. It is essential that all connections are securely made using the following code:

Brown - Live  
Blue - Neutral  
Green/Yellow - Earth

- Do not carry or pull the pump using the supply cord.
- Disconnect electrical supply from all appliances in the pond including pumps and filters before contact with the pond water or pump.
- Closely supervise children when near to pond or pond equipment.
- Use pump only for ponds - do not use pump in connection with swimming pools, showers, etc.
- Use conduit approved by your electricity authority to protect supply cord where damage from gardening equipment, children and animals may occur.
- Discard pump if motor (H) shows visual defects (e.g. cracks or swelling).
- The supply cord of this appliance cannot be replaced; if the cord is damaged the appliance should be discarded.
- Do not allow the pump to run dry.
- Do not operate the pump in freezing conditions. Remove, disassemble and dry pump if there is a risk of pump being frozen.
- This pump is provided with a thermal cut-out switch that temporarily switches off the pump in case of overheating. The pump may restart when it has cooled.

**SAVE THESE INSTRUCTIONS**

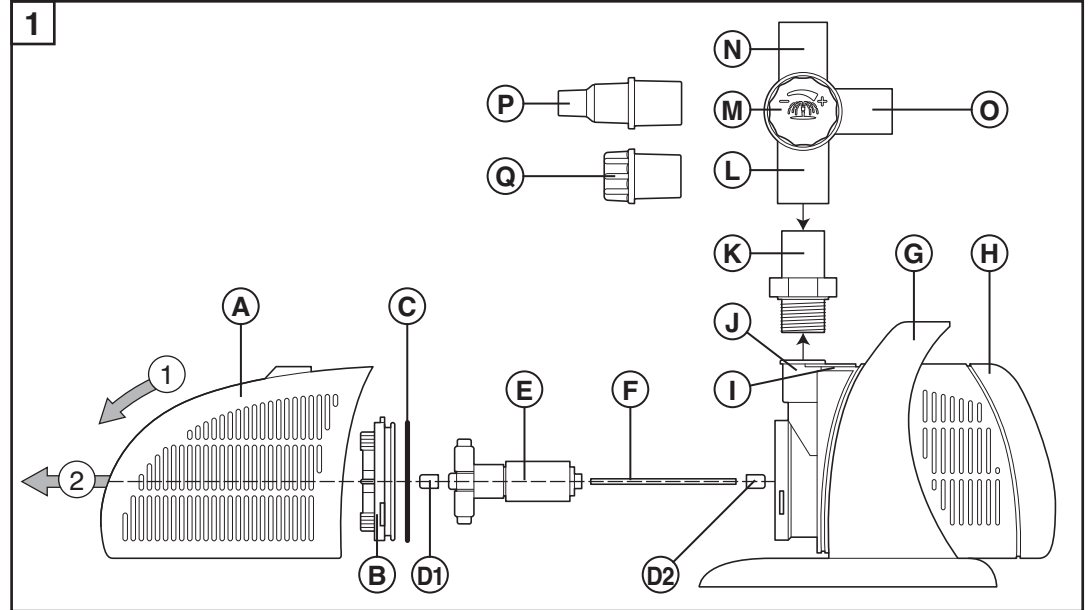

### IMPORTANT - READ BEFORE USE

#### 1. PUMP INSTALLATION

For convenience the pump should be positioned within reach from the side of the pond on a solid platform (e.g. paving slabs) approximately 250mm (10") below the pond surface. The pump should be at least 200mm (8") below water level to avoid problems of freezing and low water levels in summer and no more than 1000mm (40") deep.

**Only use pump if completely immersed in water.**

#### A. Waterfall/Filter Only

For use with a pond filter you will often get improved results with the pump sited at the opposite end of the pond to the filter return.

The pump may be connected to a waterfall or filter using 12mm (1/2"), 19mm (3/4") or 25mm (1") bore hose. Fit suitable outlet adapter (K) and flow valve (L) into pump outlet (J). Insert adapter (P) in unused outlet and adjust flow using the flow control knob (M).

#### B. Fountain (and Waterfall/Filter)

Insert fountain components as shown in Fig. 2a (conventional fountain) / 2b (bell fountain). If required tubes (R) and (T) may be shortened with a hacksaw. Also fountain (W) may be fitted directly to flow valve (N). For plume fountain do not fit any parts to tube (T). If required, connect waterfall/filter with hose to outlet (O) or (P). Alternatively, use blanking plug (Q). The Fountain heads (V) may be unscrewed anticlockwise for cleaning. Adjust fountain height/width using the flow control (M) turning clockwise for increased height. If using the bell fountain you will also need to manually adjust the gap between parts (W) and (X) for the required effect. (Try starting with approximately 1mm (1/16") gap.)

#### 2. MAINTENANCE / FAULT FINDING - IMPORTANT SAFETY INSTRUCTIONS

- **Disconnect electrical supply from pump before removing from pond or contacting pond water.**
- **Do not carry or pull the pump by the cable.**

#### A. ROUTINE MAINTENANCE OR WHEN FLOW FROM YOUR PUMP IS NOTICEABLY REDUCED OR FOUNTAIN DISPLAY HAS DETERIORATED:

- Remove strainer cover (A) as shown by arrows ① and ② in Fig. 1. Clean strainer covers (A) and (H) using a stiff brush.
- Check and remove any obstruction to inlet on impeller cover (B).
- Remove and clean fountain head in water with a brush.
- Reassemble, taking care to align cut out in top of cover (A) with grooves (I).

#### IMPORTANT

If flow is still poor check:

- Flow control (M) is correctly set.
- No blockage or kinks in outlet hose.

#### B. ONCE A YEAR OR IF FLOW IS STOPPED (CHECK POWER SUPPLY FIRST!):

Completely disassemble pump to the component parts shown in Fig. 1 as follows:

- Disconnect all items fitted to pump outlet (J).
- Remove strainer cover (A) as shown in Fig. 1.
- Remove impeller cover (B) by rotating anticlockwise. If required, pliers can be used as shown in Fig. 3.
- Carefully pull out pump impeller assembly (E) then (F).
- After cleaning of all components:
  - Check cable and pump body (G) for any damage or deterioration and discard pump if suspected faulty.
  - Check for wear of impeller (E) on shaft (F) and condition of seal (C), rubber bushes (D1) and (D2). Replace with new parts using the appropriate FISH MATE service kit as required.
- Carefully reassemble as follows:
  - Locate shaft (F) into rubber bush (D2) inside pump body (G).
  - Carefully and slowly slide impeller assembly (E) on to shaft (F) to avoid damage from the powerful magnet.
  - Lubricate rubber bush (D1) by immersing in water and then push halfway on to the end of shaft (F). Align impeller cover (B) before pushing on fully and rotating clockwise into position.
  - Refit front cover (A) taking care to align cut out with grooves (I).



**IMPORTANT:** Dispose of damaged/faulty/end-of-life products in accordance with locally applicable regulations for your country. **EU:** Refer to Terms and Conditions section *EU Waste Electrical and Electronic Equipment (WEEE) Directive* on [www.pet-mate.com](http://www.pet-mate.com) for more information.



Hereby, Pet Mate Ltd., declares that this product is in compliance with the essential requirements and other relevant provisions of EU Directives. All Declarations of Conformity (DoC) may be viewed at [www.pet-mate.com/eudoc](http://www.pet-mate.com/eudoc).

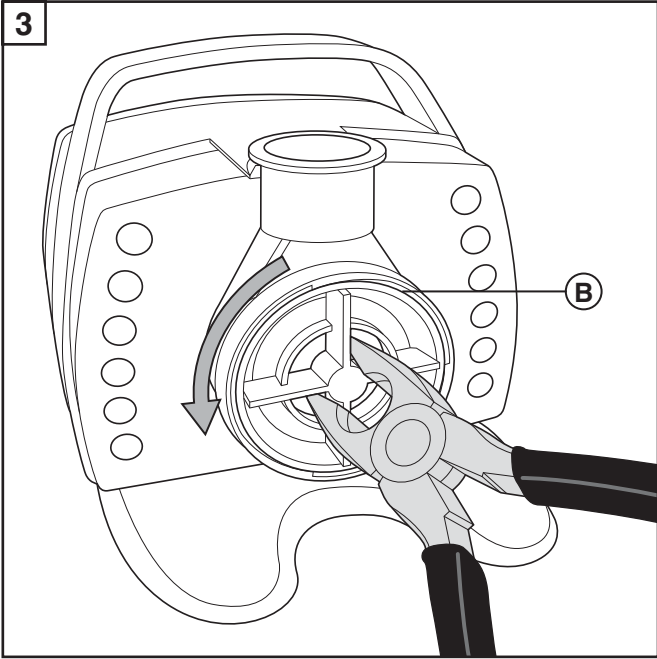
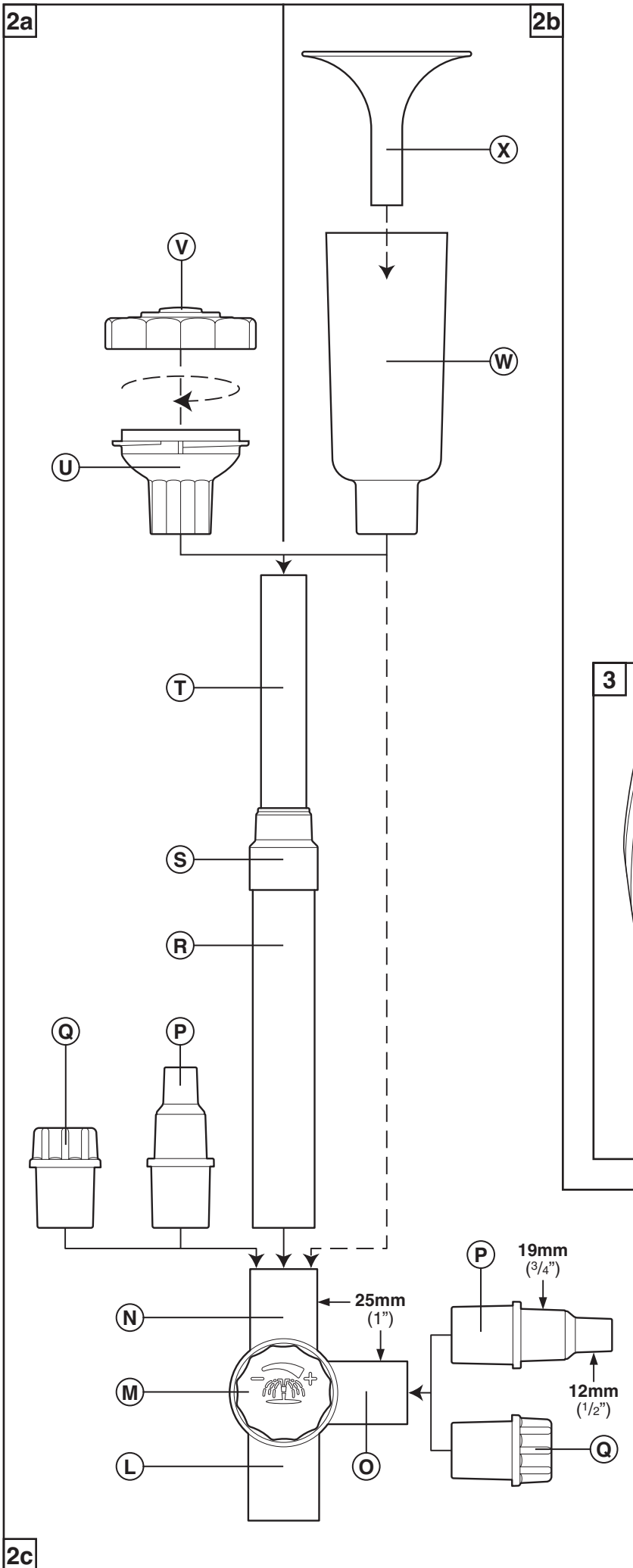

**GUARANTEE**

Pet Mate Ltd. guarantees your product for a period of 3 years from the date of purchase, subject to the registration of your purchase details on our website [www.pet-mate.com/uk](http://www.pet-mate.com/uk) within 14 days of purchase. (If you do not have access to a computer, please send details of your purchase with copy of receipt along with your name and address.) In the event of a fault developing contact Pet Mate customer services for a returns authorisation number. The guarantee is limited to any defect arising due to faulty materials or manufacture. Any defective item will be repaired or replaced free of charge at the manufacturer's discretion, provided that the defect has not been caused by neglect, misuse or normal wear and tear. The guarantee excludes moving parts and claims arising from frost, accidental damage or loss of fish. Your statutory rights are not affected.