

F9W ASSEMBLY GUIDE

VERSION: F9W-001-150LB/200LB/225LB

PART #: 5775001-C

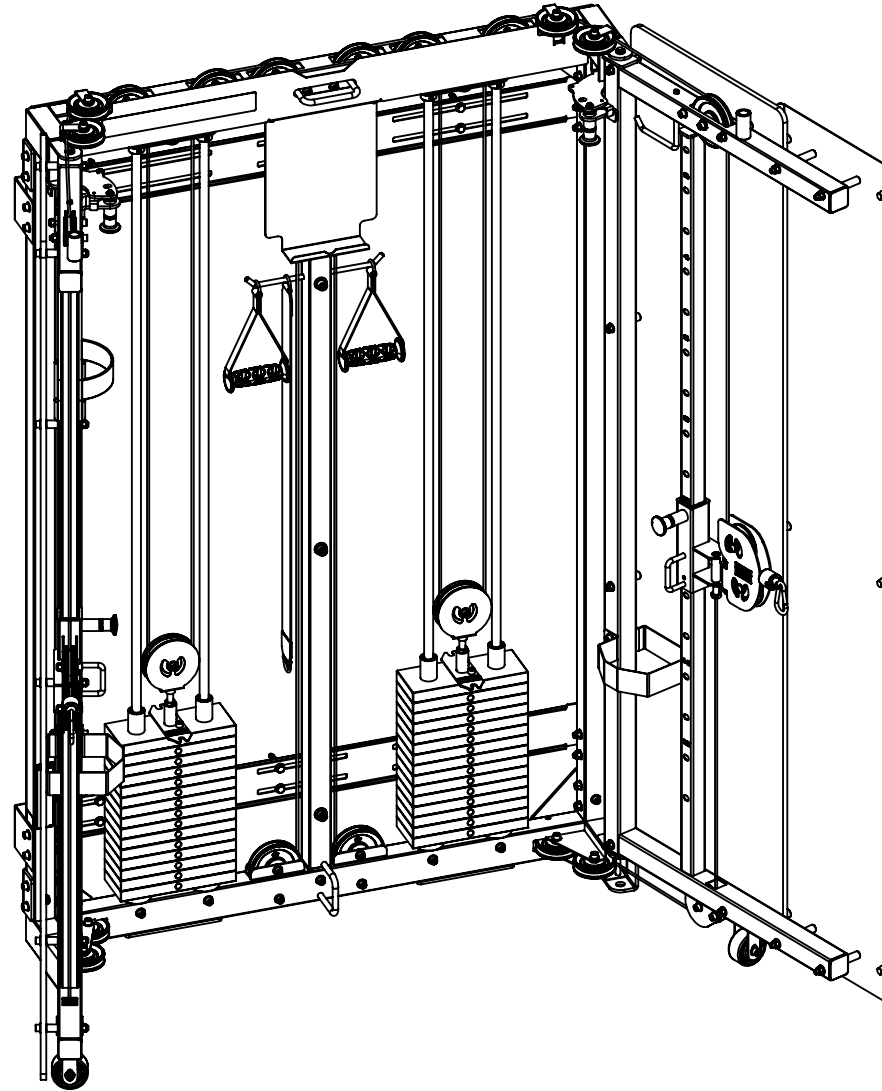

TORQUE USA

TABLE OF CONTENTS

Important safety instructions:

- Important safety instructions for using equipment: **Page 3**
- Important safety instructions for assembling equipment: **Page 3**
- Obtaining service: **Page 3**

General Notes:

- Unpacking equipment: **Page 4**
- Tools Required: **Page 4**
- Optional equipment: **Page 4**
- Assembly tips: **Page 4**

Parts List: **Page 5**

Assembly Instructions: **Pages 6 - 43**

Adjustments and Maintenance:

- Cable adjustments: **Pages 30 & 34**
- Attachment and adjustment instructions: **Pages 44 - 46**
- Maintenance: **Page 46**
- Resistance Ratio Chart: **Page 47 & 48**

WARNING !

Important safety instructions for using Equipment

There is a risk assumed by the individuals who use this type of equipment. To minimize risk, you must follow these precautions:

1. **READ ALL INSTRUCTIONS AND WARNING LABELS COMPLETELY PRIOR TO ANY USE OR ASSEMBLY.** Failure to read and follow the safety instructions and warnings within the Assembly and Maintenance Guide may result in possible serious injury or death. Use this product only for the intended uses described in the Assembly and Maintenance Guide and exercise booklet. **DO NOT** modify equipment in anyway. **Any use other than as intended or modification of product will void any and all product warranties.**
2. Consult your physician before starting any exercise program. Warm up properly before engaging in resistance training. Stop exercising and consult a physician immediately if you experience dizziness, nausea, faintness, chest pain, shortness of breath or any other abnormal symptoms during use of this equipment.
3. Certain exercise equipment and/or equipment may not be suitable or appropriate for pregnant women, people with heart conditions, balance impairment or other pre-existing health problems. Persons with disabilities should consult a physician and obtain medical approval prior to using this product and should only use this product under close supervision. **Failure to comply with these instructions will void any and all product warranties.**
4. Carefully inspect equipment before each use. Replace all parts at the first sign of wear or damage. Tighten all loose connections. Pay special attention to cable ends and connections. Do not disassemble, remove any parts or components or otherwise attempt to repair this product. **DO NOT** use product if product appears damaged. **DO NOT** attempt to fix a broken or jammed machine, obtain assistance from your authorized Torque Fitness Dealer. **Failure to comply with these instructions will void any and all product warranties.**
5. Keep body and clothing clear of all moving parts. Do not put any foreign on or near this product when in use. Wear comfortable clothing which does not impair freedom of movement. Do not wear clothing which is too loose and could get caught in moving parts.
6. Make sure all adjustment spring pins are fully engaged after making an adjustment and before using the product.
7. Make sure weight stack selector pin is completely inserted into the weight stack before beginning any exercise.
8. Children and pets must not be allowed near this machine. Supervise teenagers. This product is not a toy.
9. If unsure of proper use of this product, contact Torque Fitness Customer service at: 763-754-7533 (8:30 am - 5:00 pm CST). or 1-877-TORQUE5 (1-866-664-9894). www.service@torquefitness.com

Important Safety Instructions for Assembling Equipment

1. **Assistance is required. Torque Fitness recommends using more than one person to assemble this equipment.**
2. This product must be assembled on a flat, level surface to assure its proper function. Locate the unit a few inches from walls or furniture to allow easy access during assembly and use.
3. Read each numbered step in Assembly and Maintenance Guide and follow the steps in sequence. Skipping ahead may result in damage to the equipment and may require components to be disassembled.
4. Wear proper attire during the assembly process. Do not wear clothing which is too loose or open toed shoes.

Obtaining Service

Do not attempt to service the product yourself except for maintenance tasks described in this manual.

Refer to the Adjustments and Maintenance section at the back of this manual and the included workout booklet for information on product operation and service.

For further information, visit our website at www.torquefitness.com or contact us at www.service@torquefitness.com

If you call or email customer service, have the model number and serial number(s) available. The location of the model and serial numbers are indicated in the back of this manual. For future reference, write the model and serial number(s) in the space below.

Model Number: _____

Serial Number(s): _____

GENERAL NOTES

CAUTION: More than one person is required to assemble this unit. Do not attempt to assemble by yourself.

Unpacking the Equipment

This product may be packaged and shipped in multiple boxes. Parts from all of the boxes are required for various steps during the assembly process.

Carefully open each box and arrange all the parts near the area where assembly is to take place.

CAUTION: Use extreme care when cutting plastic tie wraps and package banding. A wire cutter works best for protecting yourself and the parts.

CAUTION: Some of the internal boxes may contain upholstery. Do not use a utility knife to open any boxes or the pads may be damaged.

The hardware is packed in bags. Carefully open each bag and sort them per parts list on the next page.

Before starting assembly, identify each part and hardware item as listed in the parts list on the next page. If any items are missing, contact Torque Fitness Customer service at: 763-754-7533 (8:30 am - 5:00 pm CST), or 1-877-TORQUE5 (1-866-664-9894). www.service@torquefitness.com

Note: Some items listed in the parts list may already be pre-installed on the product.

Tools Required

- Rubber mallet or hammer
- 3/4" Box wrench or adjustable wrench
- 9/16" Box wrench or adjustable wrench
- Ratchet with 9/16" socket
- 5/16" & 7/32" Allen wrench
- 4mm Metric allen wrench
- Wire snips (to cut plastic tie wraps)
- Scissors or utility knife (to cut hardware bags)
- Step stool or ladder
- Tape measure

Optional Equipment

Optional equipment may be available for this product.

Follow the instructions included with the optional equipment to assemble it to the base product.

Assembly Tips

- In a continual effort to improve our products, specifications are subject to change.
- A 6" scale is provided at the bottom of every page. To correctly measure the bolts, measure from underneath the bolt head to the end of the bolt as illustrated below.
- Read all notes on each page before beginning that step.
- Some of the items shown in the assembly steps may already be pre-assembled.

Assembly Tips Continued

- **Note:** Some items have been hidden for assembly clarity.
- **Note:** Some pre-assembled parts may need to be temporarily removed in order to complete the step. Follow the instructions or damage to the product could occur.
- Some parts may have extra holes that will not be used. Use only the holes depicted in the instructions.
- Certain parts make reference to the right and left side of the machine. In order to determine the left and right side, stand with your back to the front of the machine.
- Provide ample space around the product for ease of assembly.
- **DO NOT** fully tighten any connections until instructed to do so. This will help insure that the alignment of all of the parts will be correct.
- Insert all bolts in the direction indicated in the instructions. Failure to do so may result in clearance issues and will degrade the aesthetics of the product.
- Carefully follow instructions for all pivot points. In general, primary rotating parts have connections that should be securely tightened, while secondary connections need to be loosen 1/4 turn.

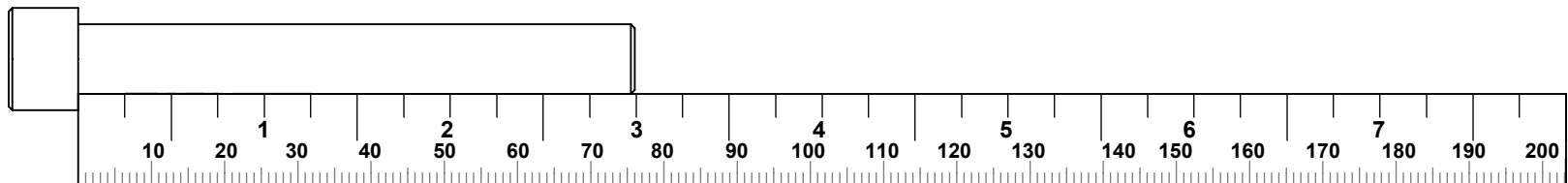

ITEM	PART NUMBER	DESCRIPTION	QTY
1	57514PA	PTD ASSY, BASE	1
2	57525PA	PTD ASSY, CORNER UPRIGHT TUBE	1
3	5752501	TUBE, CORNER UPRIGHT	1
4	2001101	WASHER, FLAT 3/8 SAE ST ZN	108
5	2008410	BOLT, 3/8-16 X 2-3/4" (70mm) ST HT SOCKET HEAD	34
6	2001201	NUT, 3/8-16 LK ST ZN	40
7	57526PA	PTD ASSY, CENTER UPRIGHT	1
8	57529PA	PTD ASSY, TOP BOOM	1
9	5754001	BRKT, F9 WALL MOUNT	2
10	2031101	SCREW, 3/8" LAG X 2.5"L CLEAR ZINC	12
11	5489201	GUIDE ROD, 19 DIA X 1880	8
12	57094PA	PTD ASSY, 10 LB WEIGHT PLATE	36
13	57388PA	PTD ASSY, 15 LB WEIGHT PLATE	47
14	57097PA	PTD ASSY, HEAD PLATE	4
15	54896PA	PTD ASSY, GUIDE ROD SUPPORT	4
16	5513601	CUSHION, WEIGHT STACK	8
17	5095301	SHAFT COLLAR, GUIDE ROD	8
18	2009409	BOLT, 3/8-16 X 2-1/2" (64mm) ST HT SOCKET HEAD W/NP	6
19	5487101	WLDMT, CARRIAGE UPRIGHT	2
20	5795401	ASSY, RIGHT CARRIAGE	1
21	57546PA	PTD ASSY, RIGHT DOOR	1
22	2009403	BOLT, 3/8-16 X 1" (25mm) ST HT SOCKET HEAD W/NP	2
23	5816301	PIN, DOOR PIVOT	4
24	5795801	ASSY, LEFT CARRIAGE	1
25	57553PA	PTD ASSY, LEFT DOOR	1
26	5466201	WHEEL, 3" OD X 1/2" ID X 1-1/2"	2
27	5466601	SPACER, WHEEL HUB	2
28	2008409	BOLT, 3/8-16 X 2-1/2" (64mm) ST HT SOCKET HEAD	2
29	2008406	BOLT, 3/8-16 X 1-3/4" (45mm) ST HT SOCKET HEAD	4
30	5094401	PULLEY, 3-1/2 OD X 25	6
31	5500701	LABEL, WEIGHT STACK 1-20	2
32	5666401	ASSY, WEIGHT STACK PIN	2

ITEM	PART NUMBER	DESCRIPTION	QTY
33	55181PA	PTD ASSY, WEIGHT SELECTOR STORAGE PLATE	2
34	54970PA	PTD ASSY, HEAD PLATE PULLEY	2
35	2009402	BOLT, 3/8-16 X 3/4" (19mm) ST HT SOCKET HEAD W/NP	4
36	2002601	NUT, 1/2 JAM ST ZN	4
37	5756301	CABLE ASSY, F9 WALL	2
38	2009406	BOLT, 3/8-16 X 1-3/4" (45mm) ST HT SOCKET HEAD W/NP	6
39	5094501	PULLEY, 4-1/2 OD X 25	2
40	5508801	HOUSING, CABLE COUPLER	2
41	5508901	GROMMET, RUBBER CABLE	2
42	5509001	CORE, CABLE COUPLER	2
43	2003201	CAP SCREW, M5 X 0.8 X 6MM SOCKET HEAD	4
44	57608PA	PTD ASSY, ACCESSORY HOLDER	1
45	57612PA	PTD ASSY, TOP BOOM SHROUD	1
46	2002101	WASHER, FLAT 1/4 SAE ST ZN	2
47	2006502	BOLT, 1/4-20 X 1/2" (13mm) SOCKET HEAD W/NP	2
48	2041701	BHCS, 3/8-16 X 1/2, GR 10.9, CZ	2
49	57814PA	PTD ASSY, ROLLER/MAT HOLDER	2
50	5755601	PANEL, DOOR SIDE	2
51	5493001	SPACER, SHROUD STAND OFF	12
52	2035801	WASHER, FLAT 3/8" SAE ST BZ	32
53	2035901	SHCS, 3/8-16 X 4" (102MM), G5, BZ	12
54	2035701	NUT, 3/8-16 LK G5 BZ	16
55	5780001	BUMPER, 18 DIA X 12.7	6
56	5755801	SHROUD, DOOR FRONT	1
57	5755701	SPACER, 50MM SHROUD STAND OFF	4
58	2036001	BOLT, 3/8-16 X 4-3/4" (121mm) ST HT SOCKET HEAD	4
59	5497501	STRAP, UNIVERSAL	1
60	57820PA	PTD ASSY, PULL-UP/PRESS BAR	1
61	5784201	ASSY, LEG BOOT, SHORT	1
62	5324701	ASSY, SHORT STRAP HANDLE	2
63	5497601	ASSY, SQUAT HARNESS W D-RING	1
64	5091801	SNAP HOOK, 8MM DIA X 80MM	2

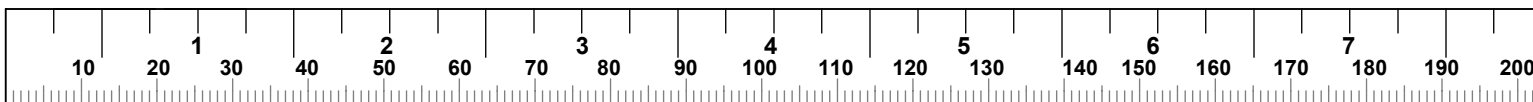

STEP 1

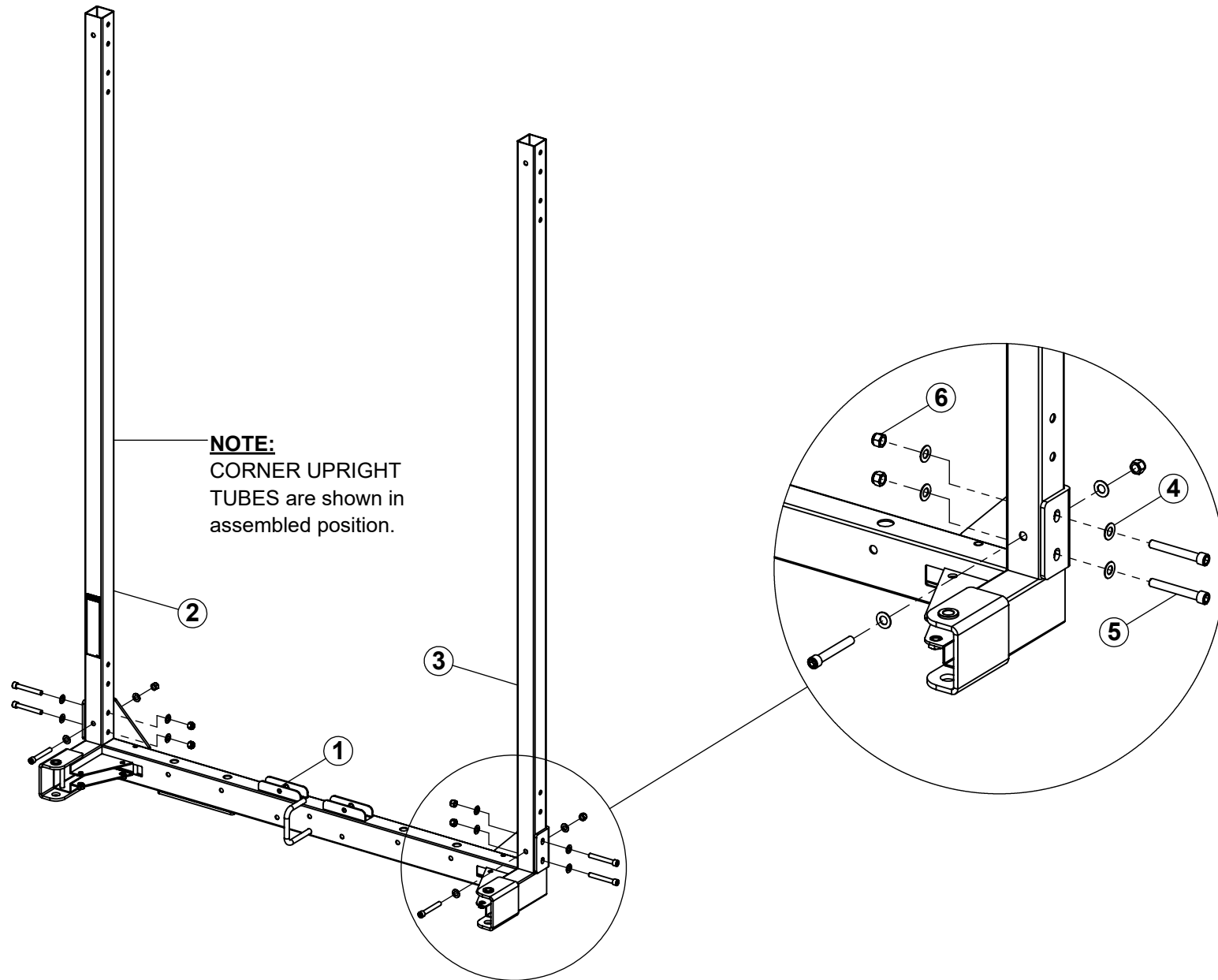

NOTE:
LOOSELY assemble bolt connections in this step.

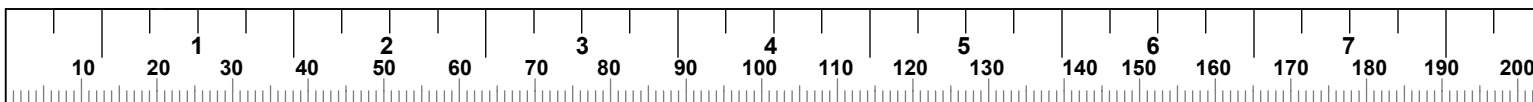

STEP 2

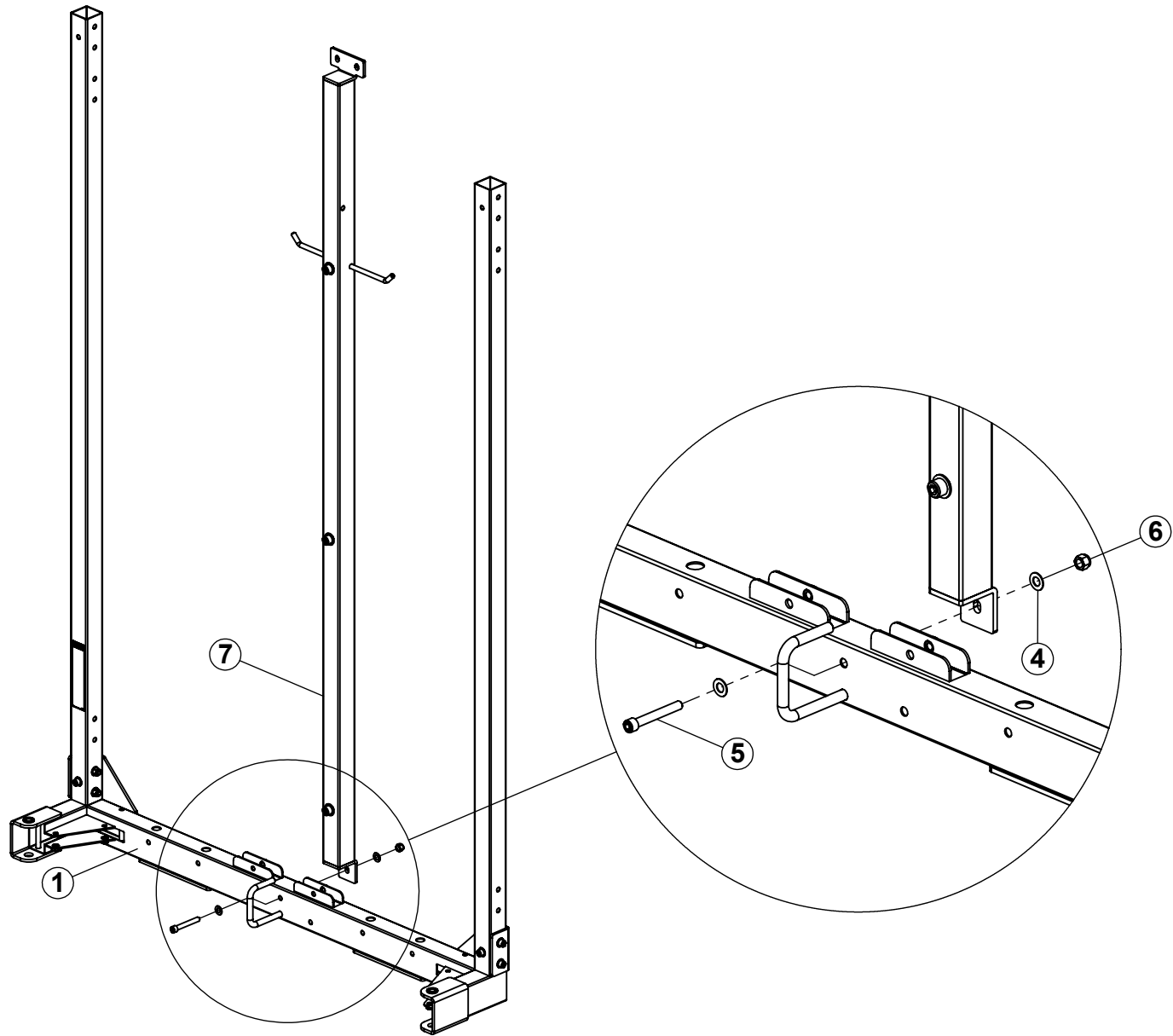

NOTE:
LOOSELY assemble bolt connections in this step.

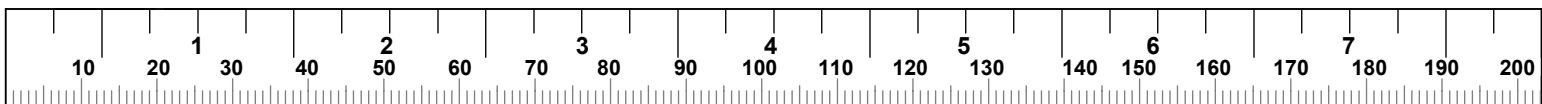

STEP 3

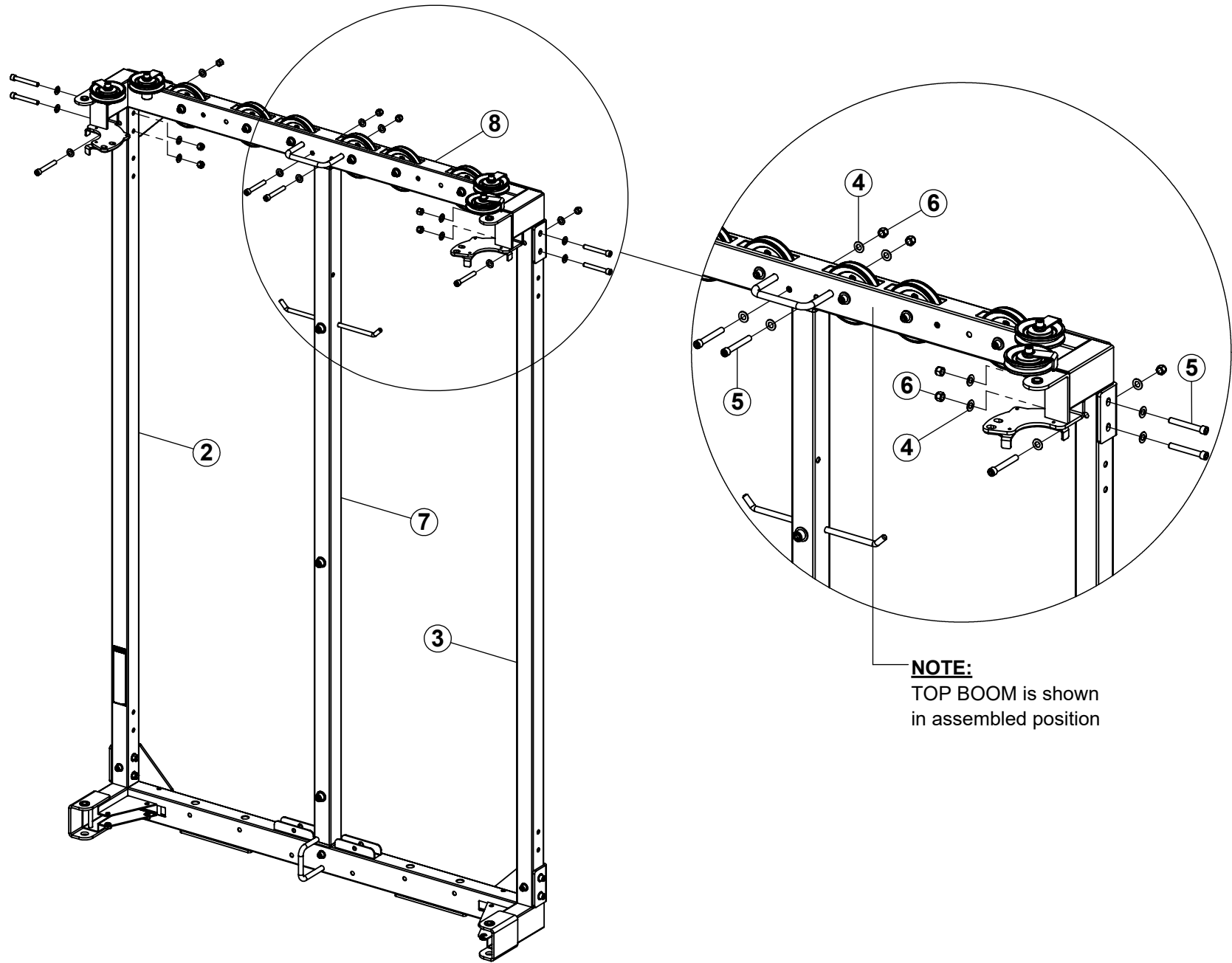

NOTE:
LOOSELY assemble bolt connections in this step.

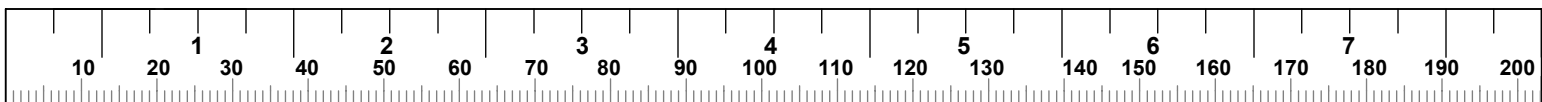

STEP 4

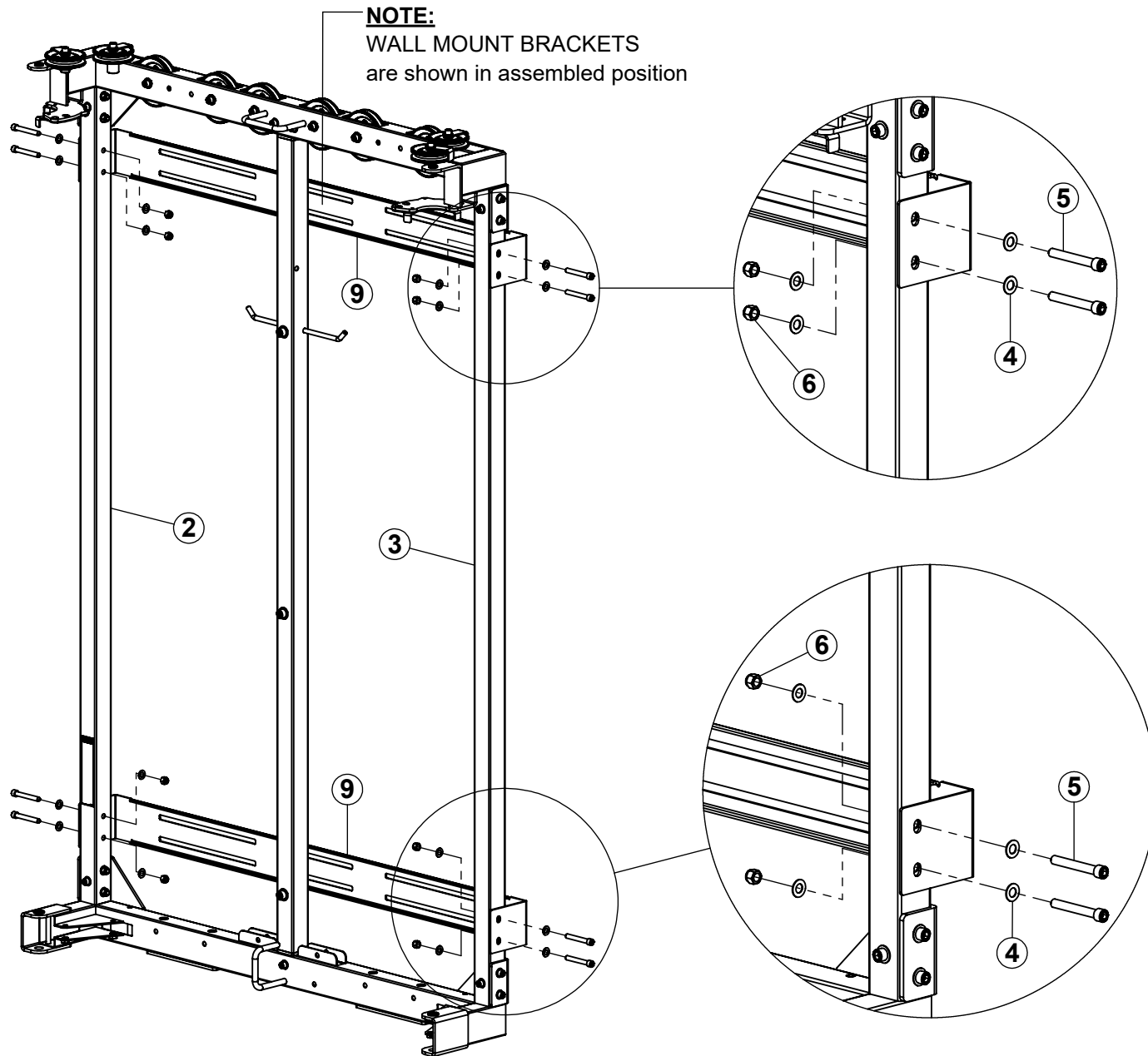

NOTE:
Once this step has been completed, **SECURELY** tighten all bolt connections in this step and previous steps.

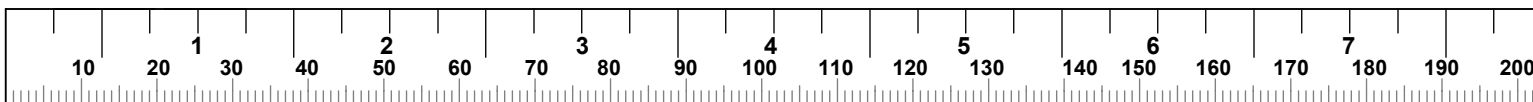

STEP 5

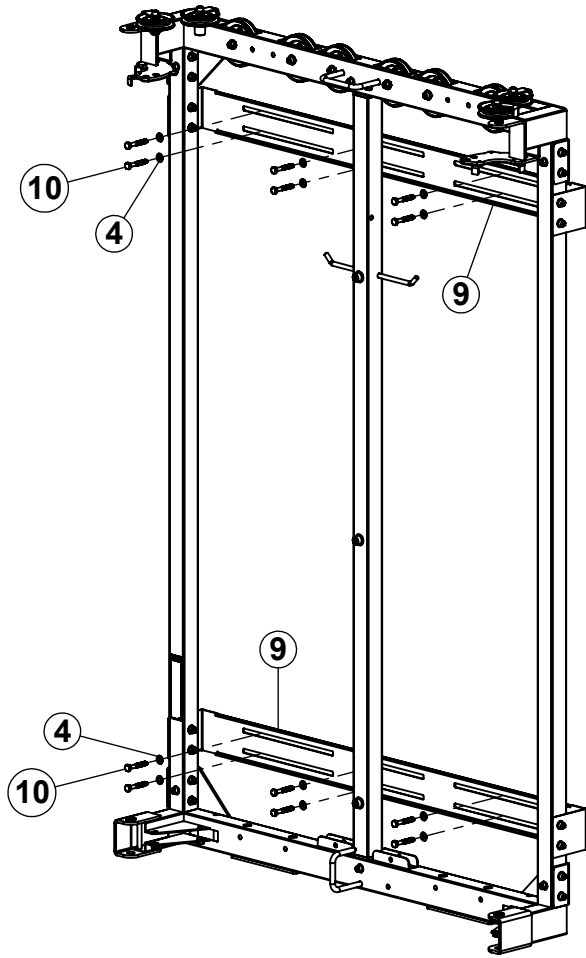

WARNING:

The UPPER and LOWER WALL MOUNT BRACKETS **MUST** be anchored to the wall using 12 wall anchors suitable for that particular wall construction.

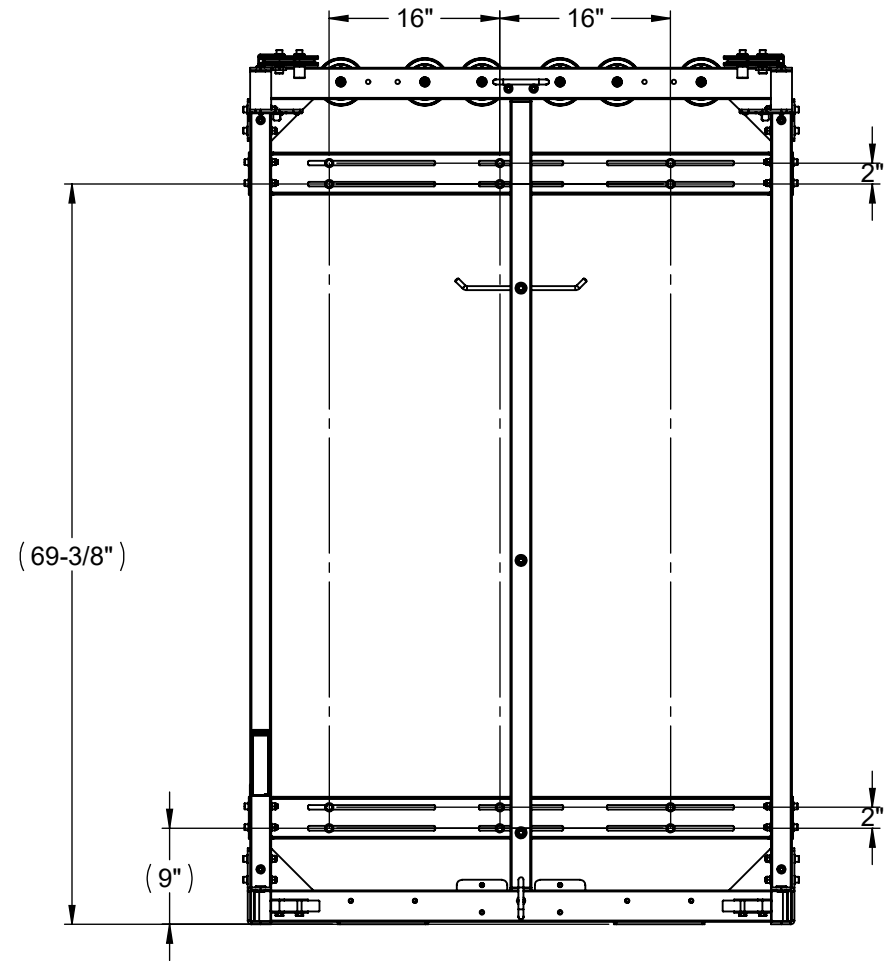

NOTES:

The images above show anchoring hardware used for attaching the WALL MOUNT BRACKETS to a typical wall with wood studs spaced 16" on center. The anchors used will depend on the wall construction.

All twelve anchoring locations must be used. The pull-out strength of the anchoring bolts used must be equal to or greater than 200 lbs. (91 kg)

NOTE:

The dimensions shown are for reference only. Dimensions are based on the UPRIGHTS and floor being level.

SECURELY tighten bolt connections in this step.

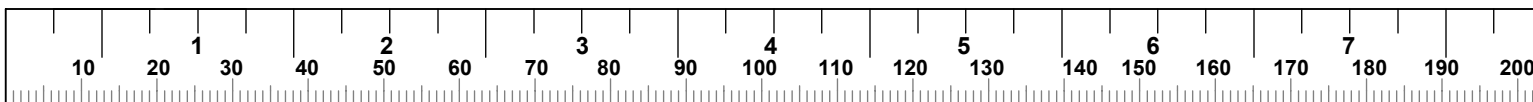

STEP 6 (150 LB OPTION)

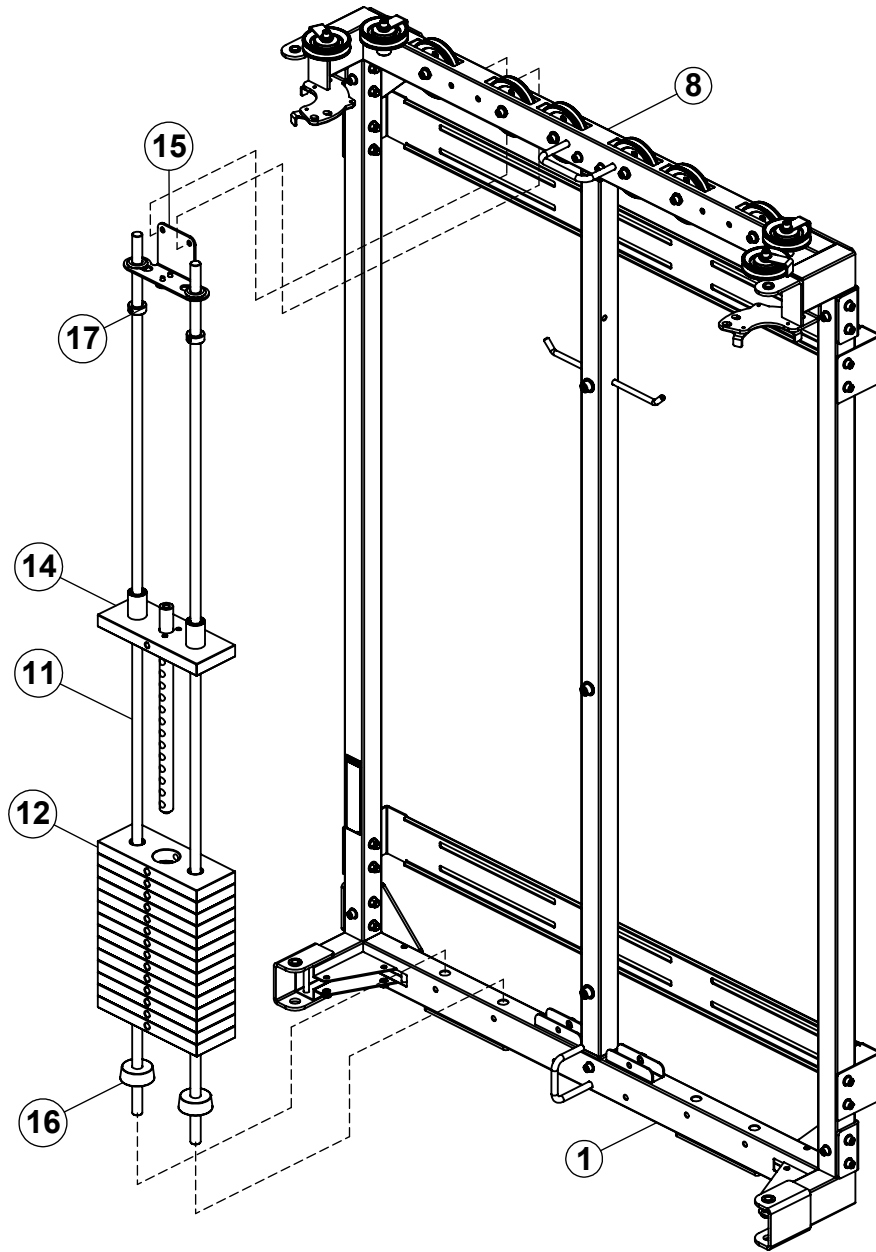

STEP 6 (200 LB OPTION)

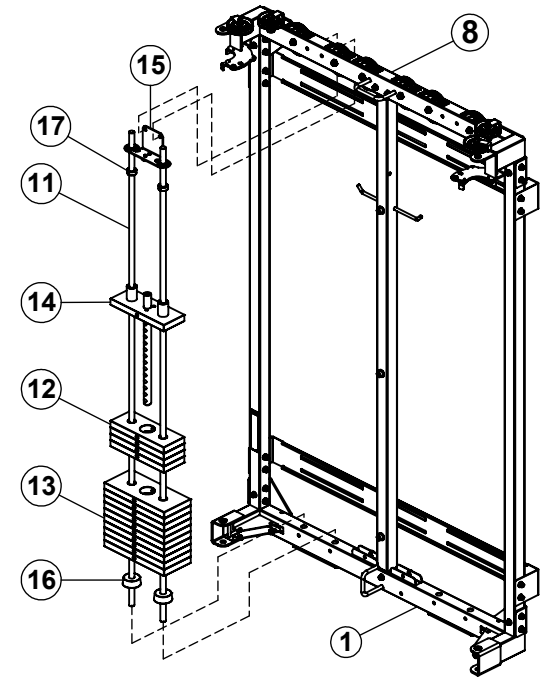

STEP 6 (225 LB OPTION)

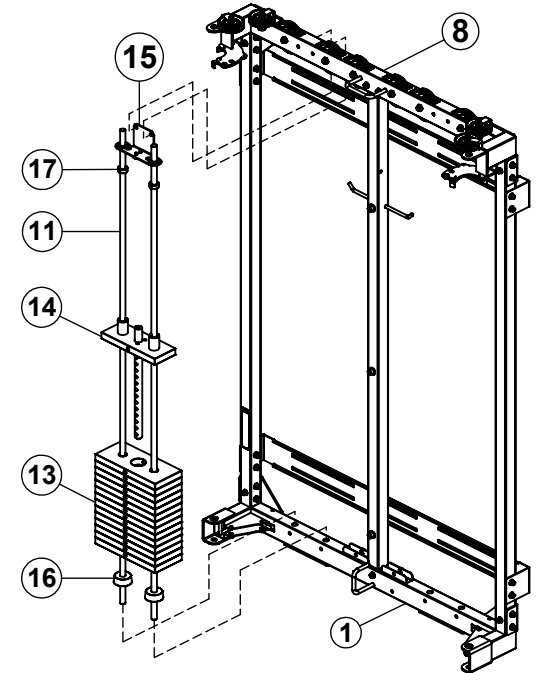

STEP 7

NOTE 2:

After everything has been assembled, slide SHAFT COLLARS up to GUIDE ROD SUPPORT and tighten set screws.

NOTE 1:

Lift up on GUIDE RODS and insert bolts underneath

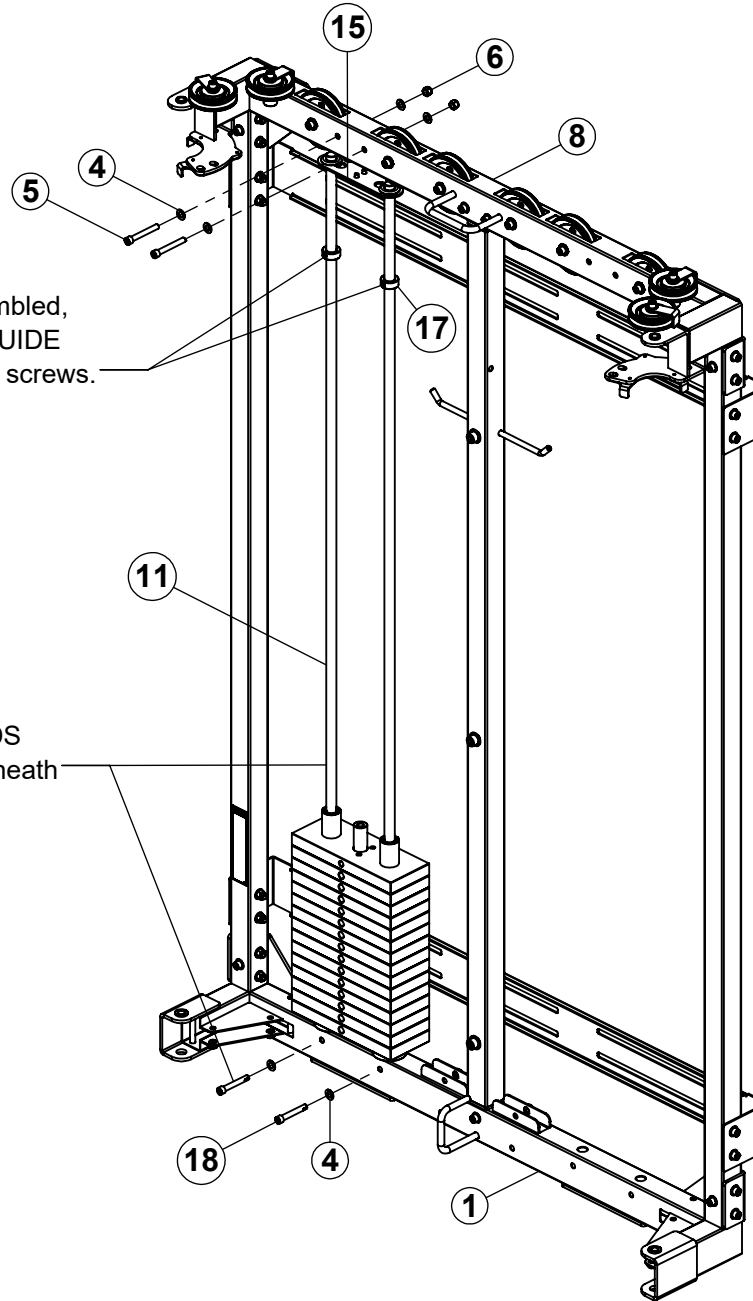

NOTE:
SECURELY tighten bolt connections in this step.

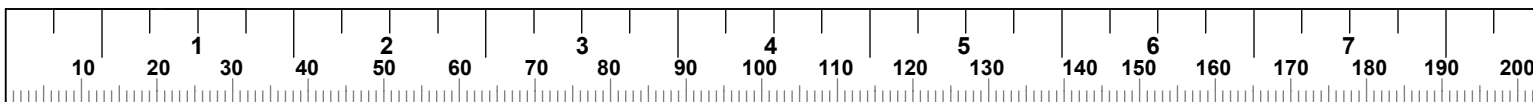

STEP 8 (150 LB OPTION)

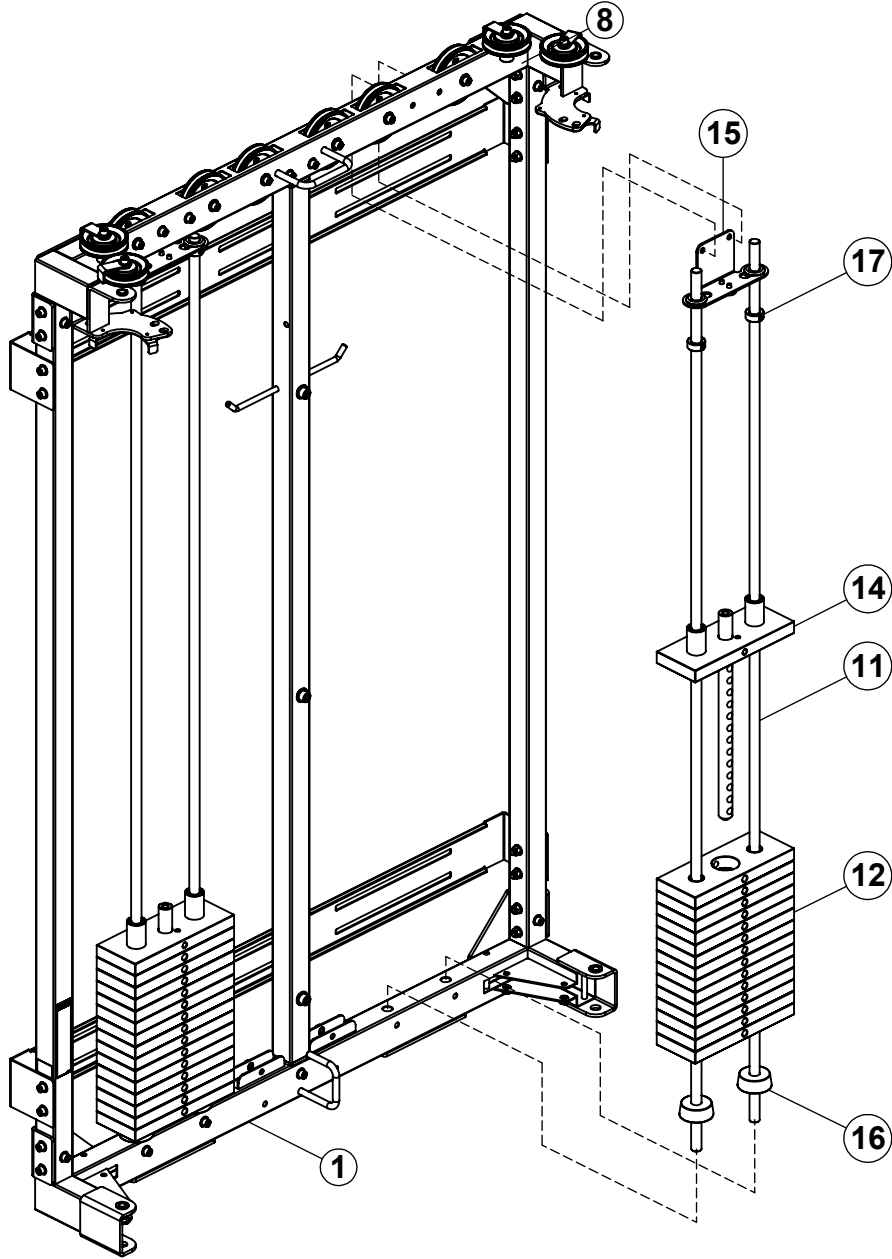

STEP 8 (200 LB OPTION)

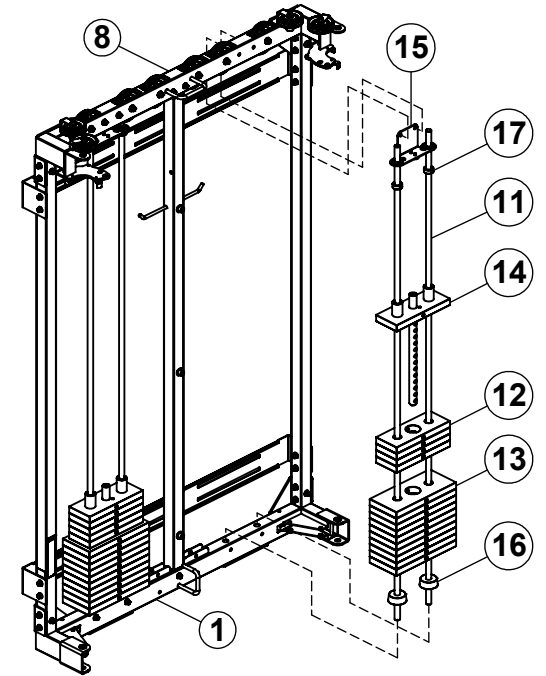

STEP 8 (225 LB OPTION)

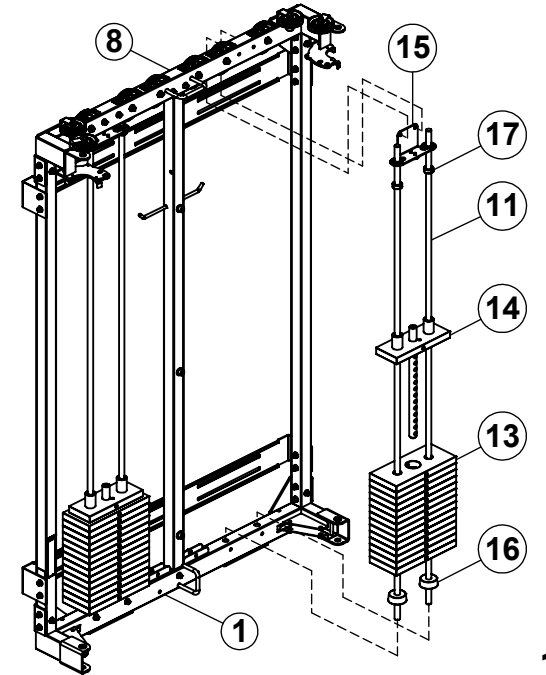

STEP 9

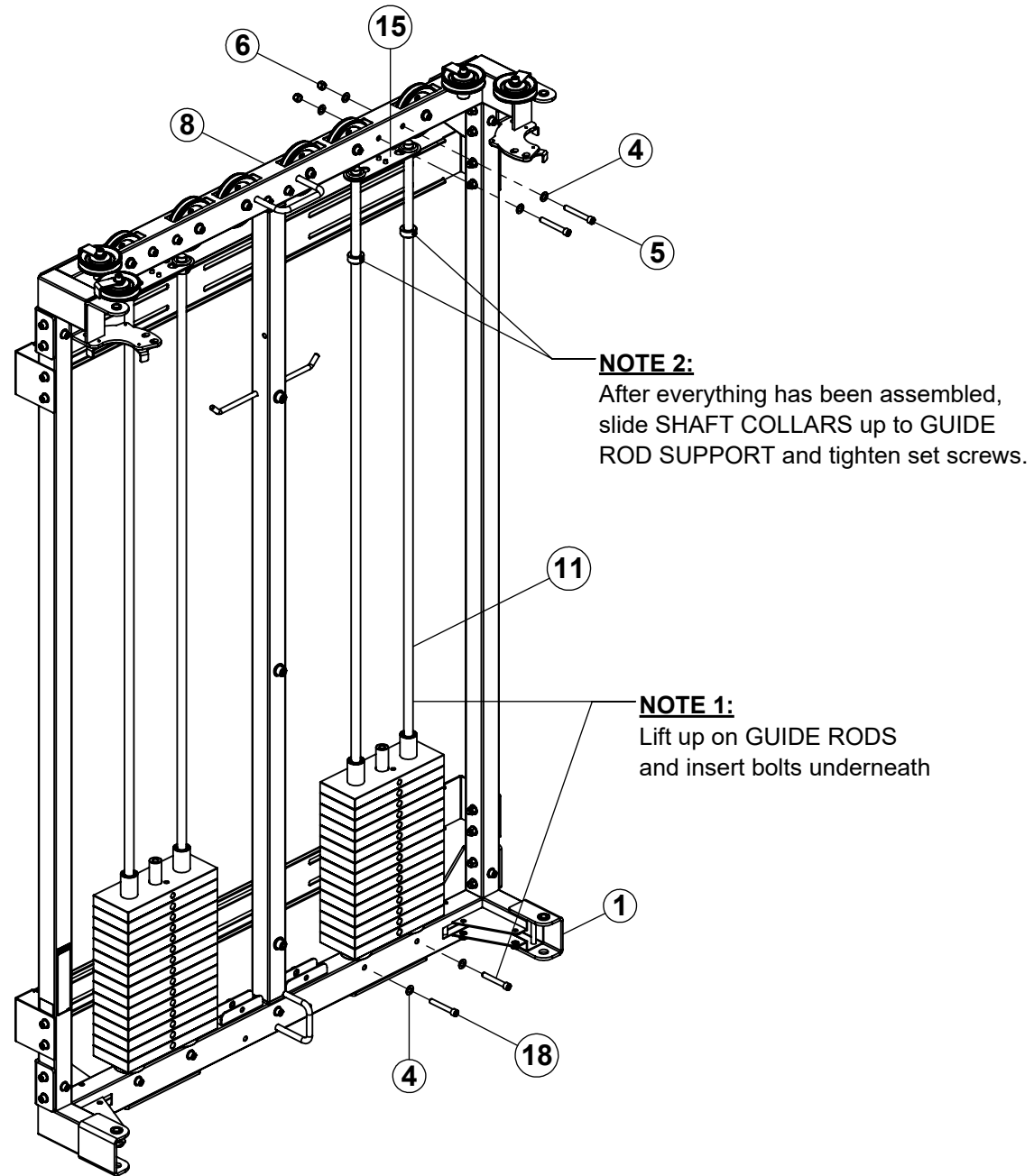

NOTE:
SECURELY tighten bolt connections in this step.

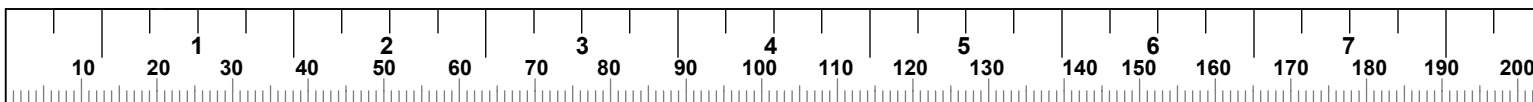

STEP 10

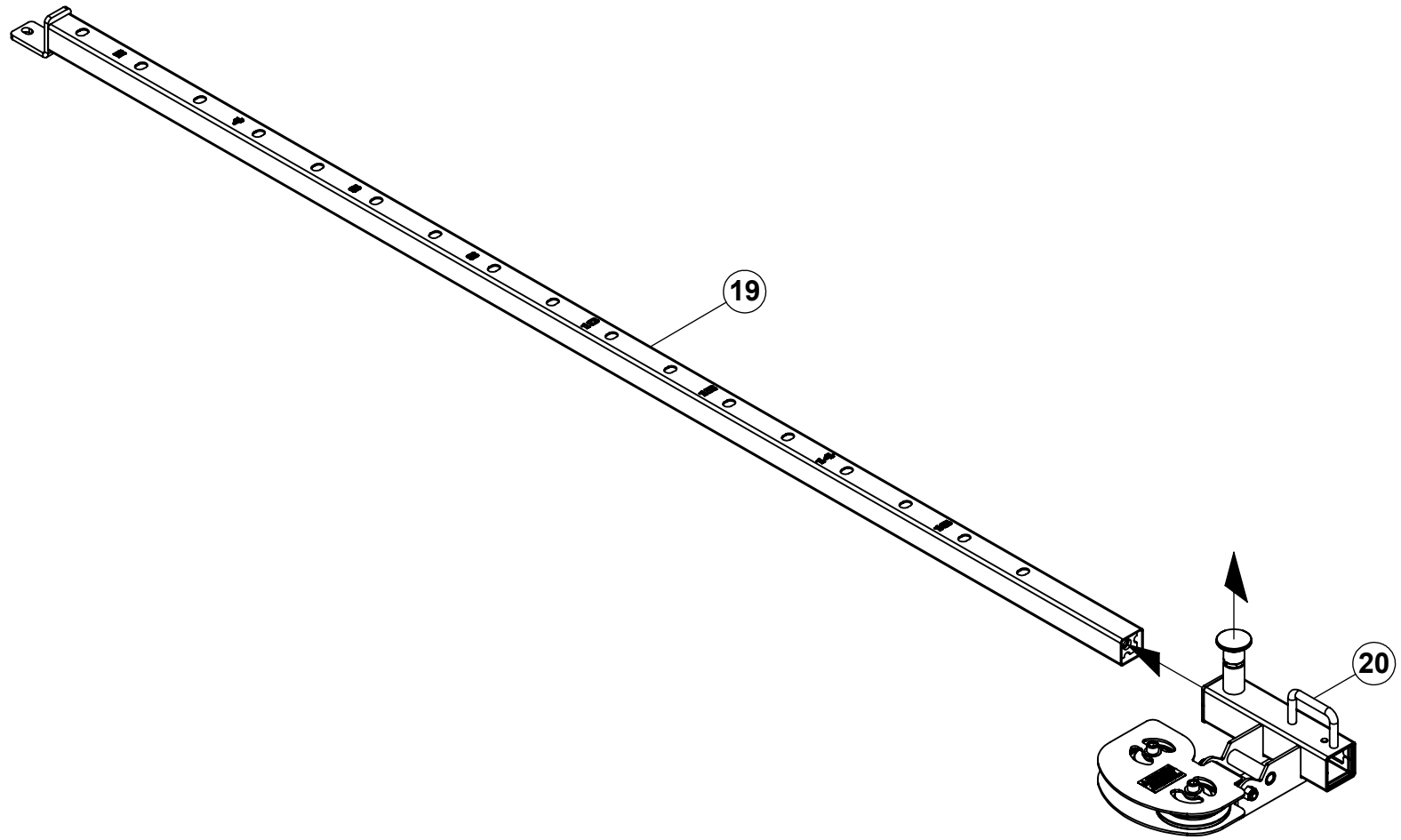

STEP 11

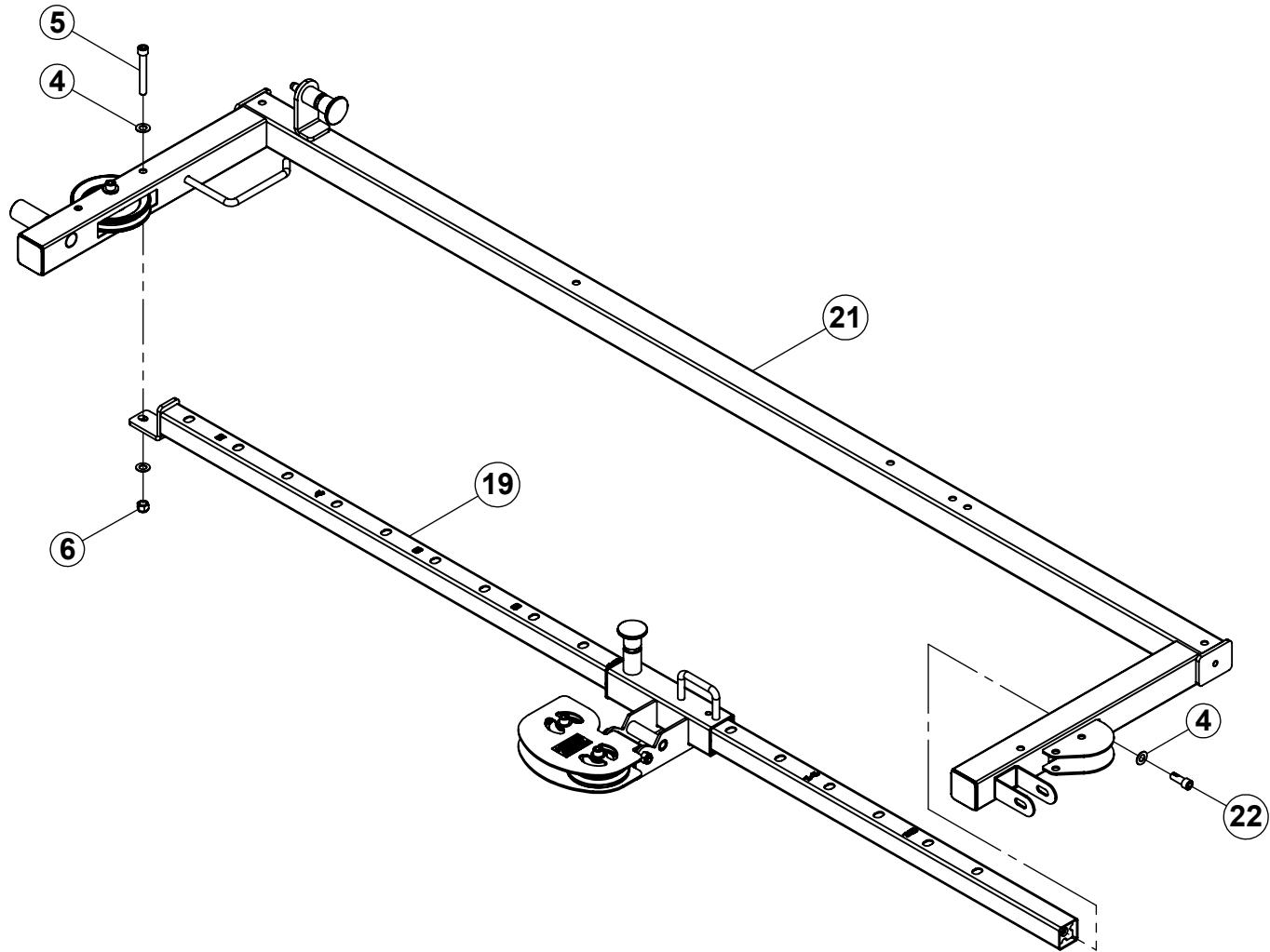

NOTE:
SECURELY tighten bolt connections in this step.

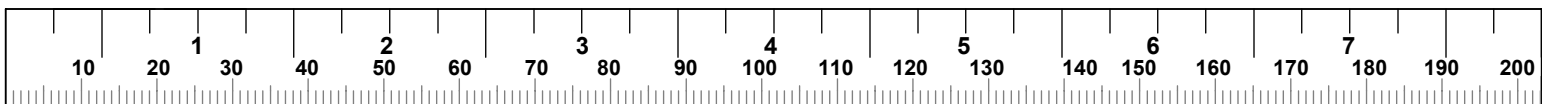

STEP 12

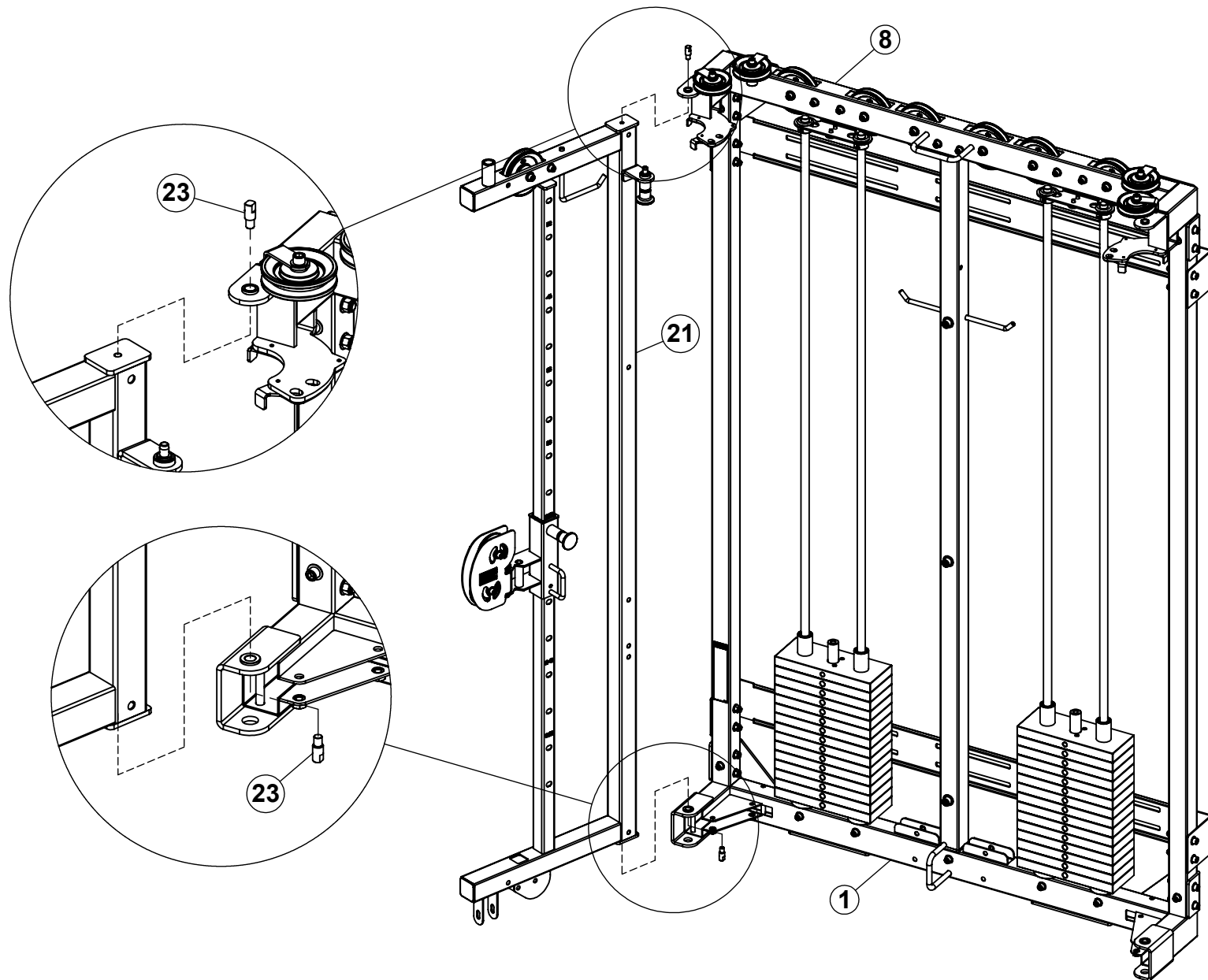

NOTE:
SECURELY tighten bolt connections in this step.

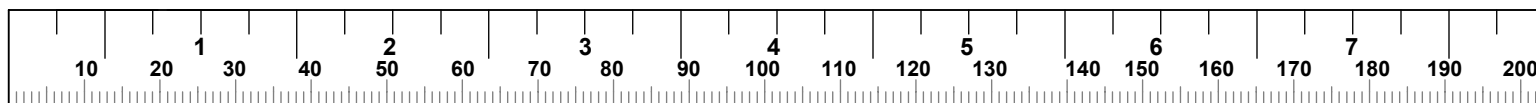

STEP 13

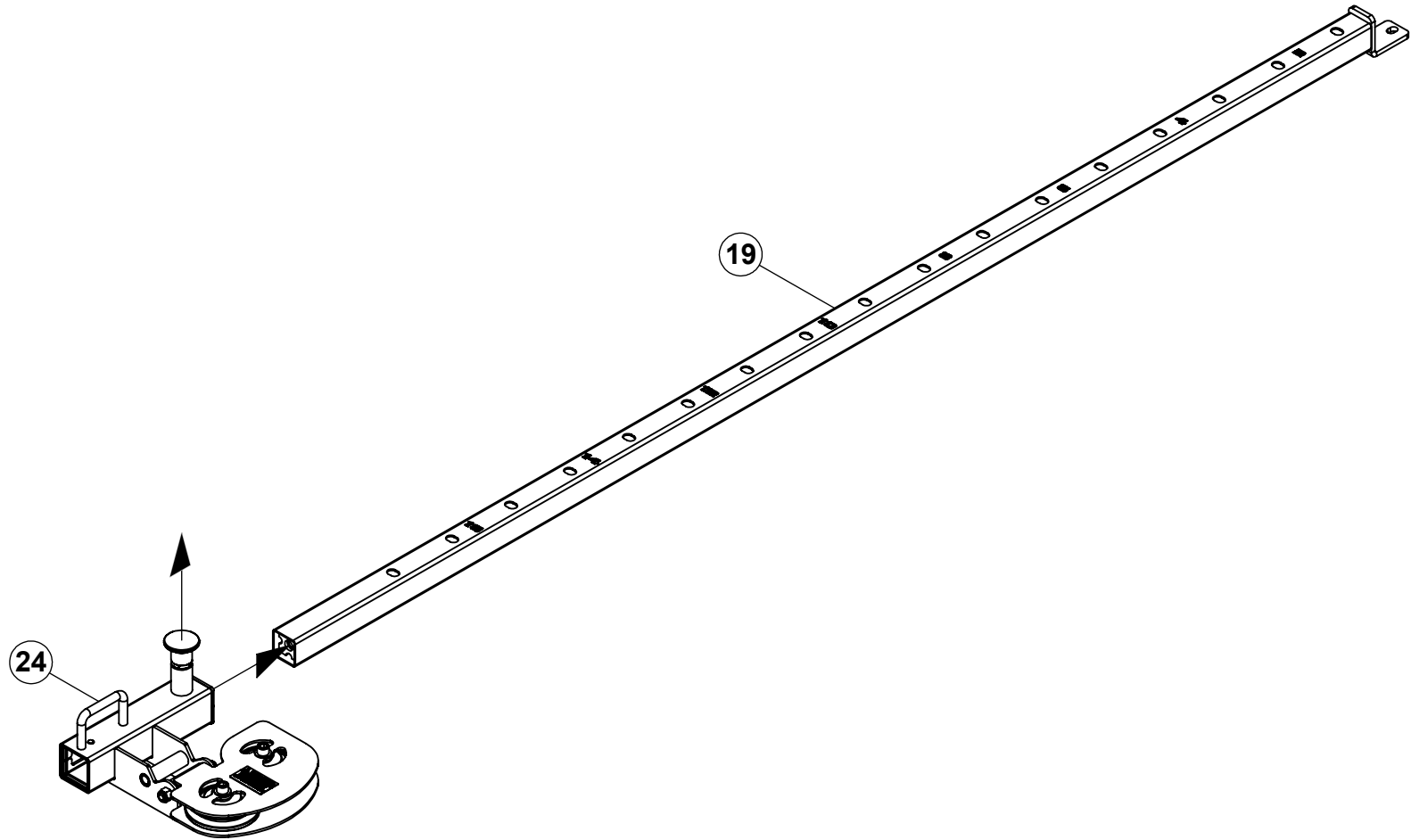

STEP 14

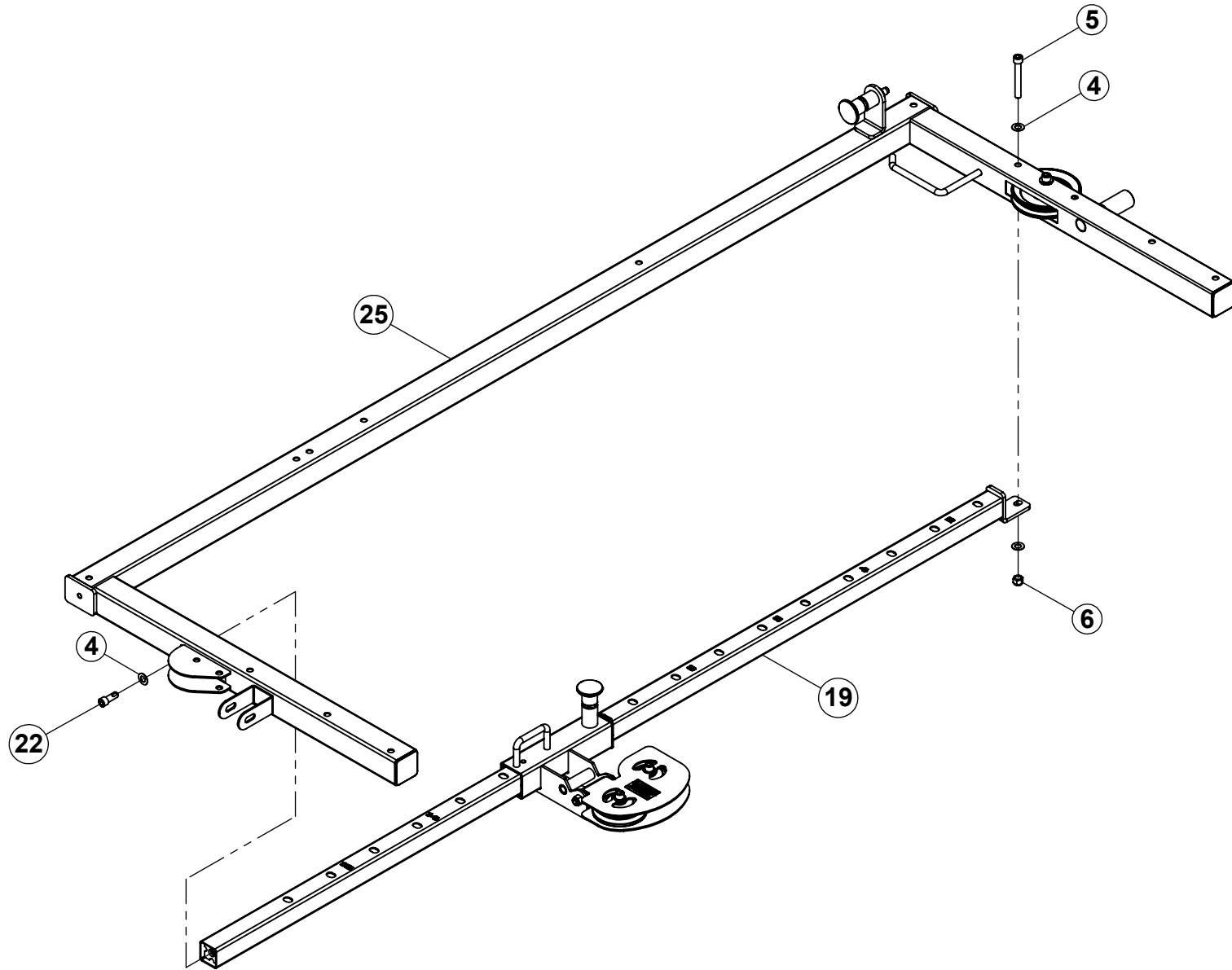

NOTE:
SECURELY tighten bolt connections in this step.

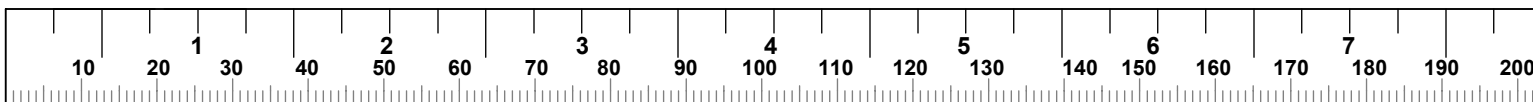

STEP 15

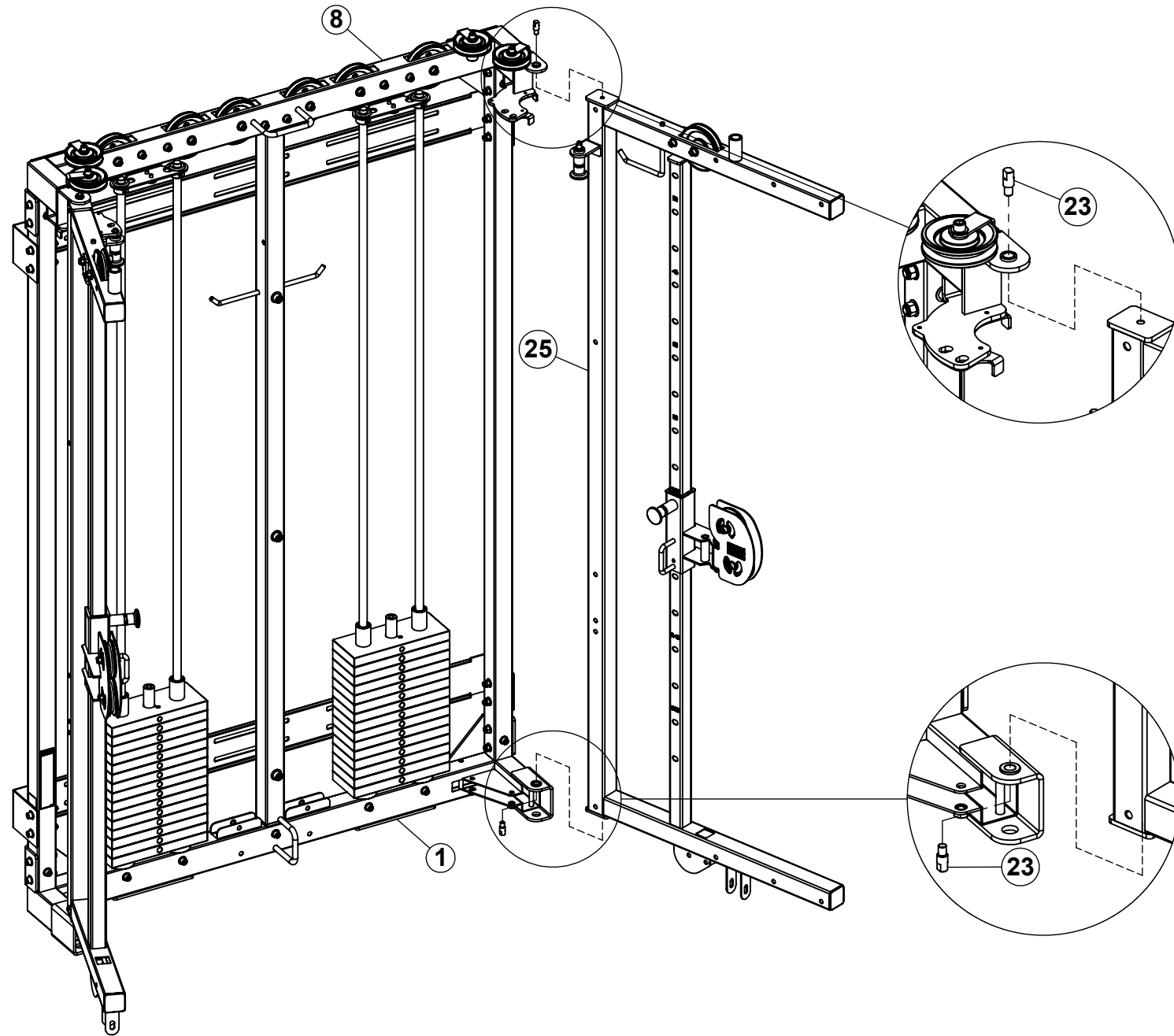

NOTE:
SECURELY tighten bolt connections in this step.

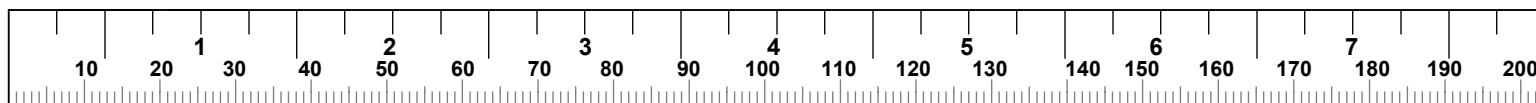

STEP 16

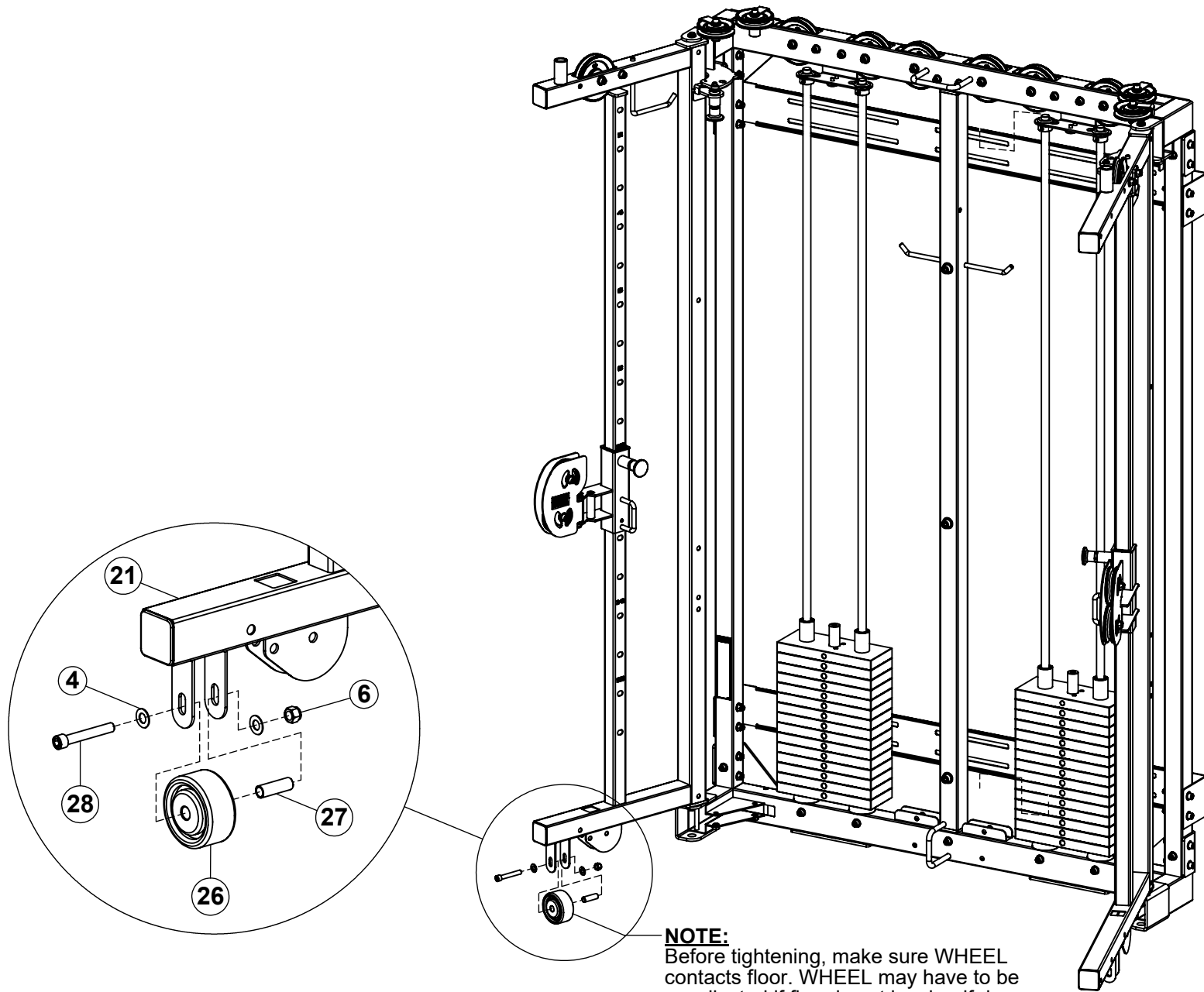

NOTE:
Before tightening, make sure WHEEL contacts floor. WHEEL may have to be re-adjusted if floor is not level or if door is difficult to open or close

NOTE:
SECURELY tighten bolt connections in this step.

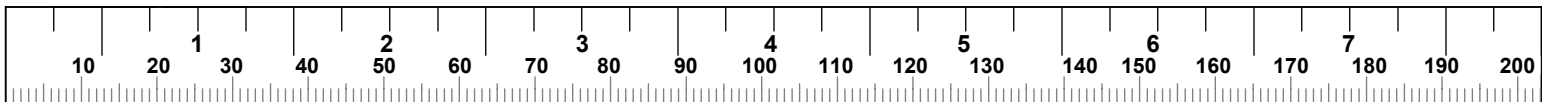

STEP 17

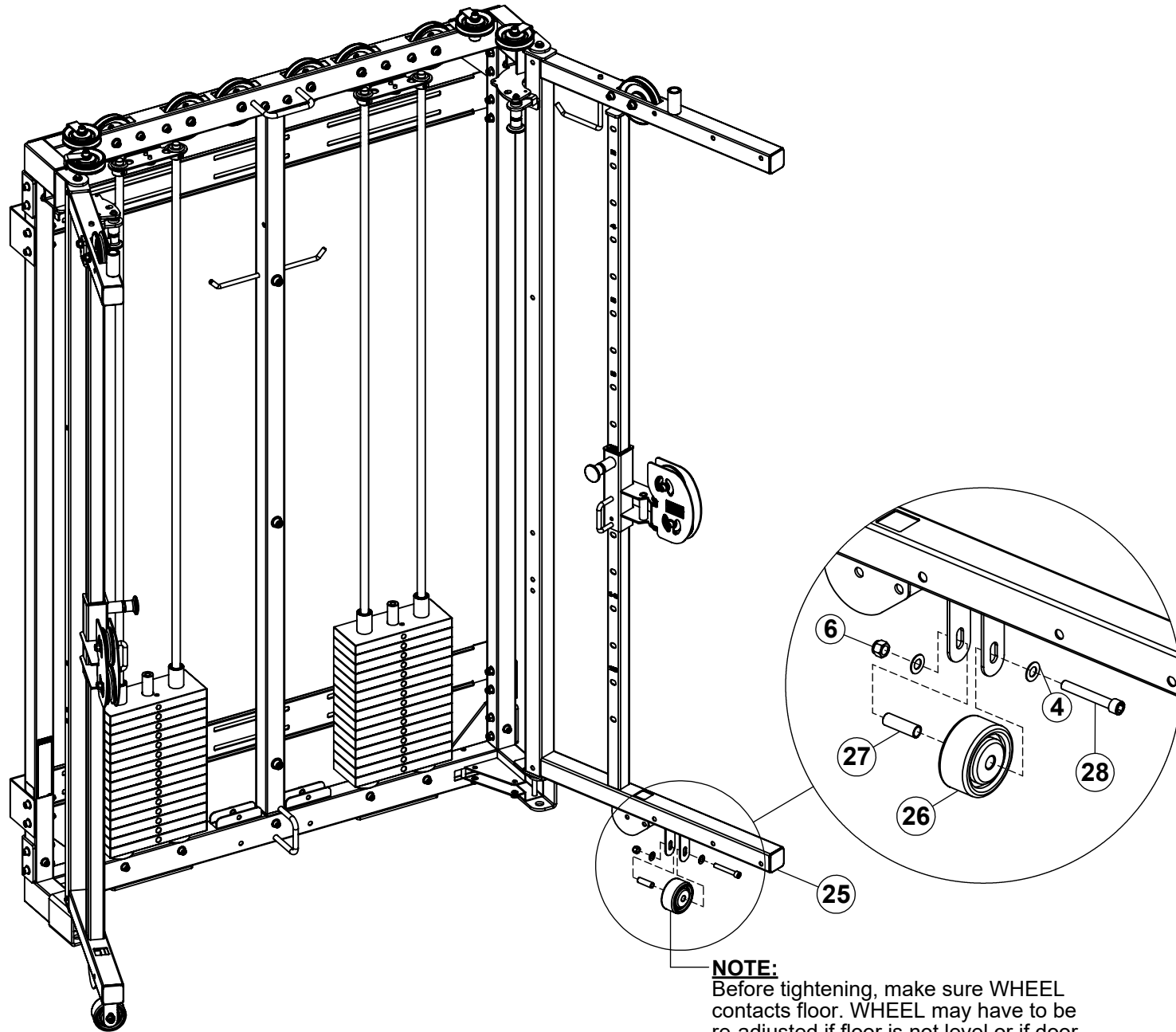

NOTE:
Before tightening, make sure WHEEL contacts floor. WHEEL may have to be re-adjusted if floor is not level or if door is difficult to open or close

NOTE:
SECURELY tighten bolt connections in this step.

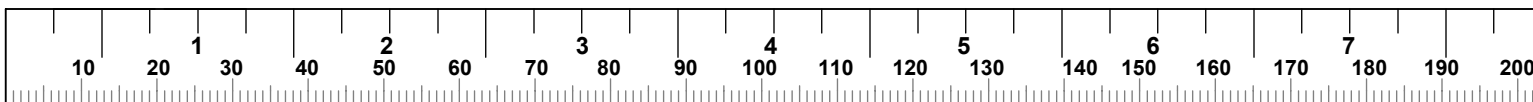

STEP 18

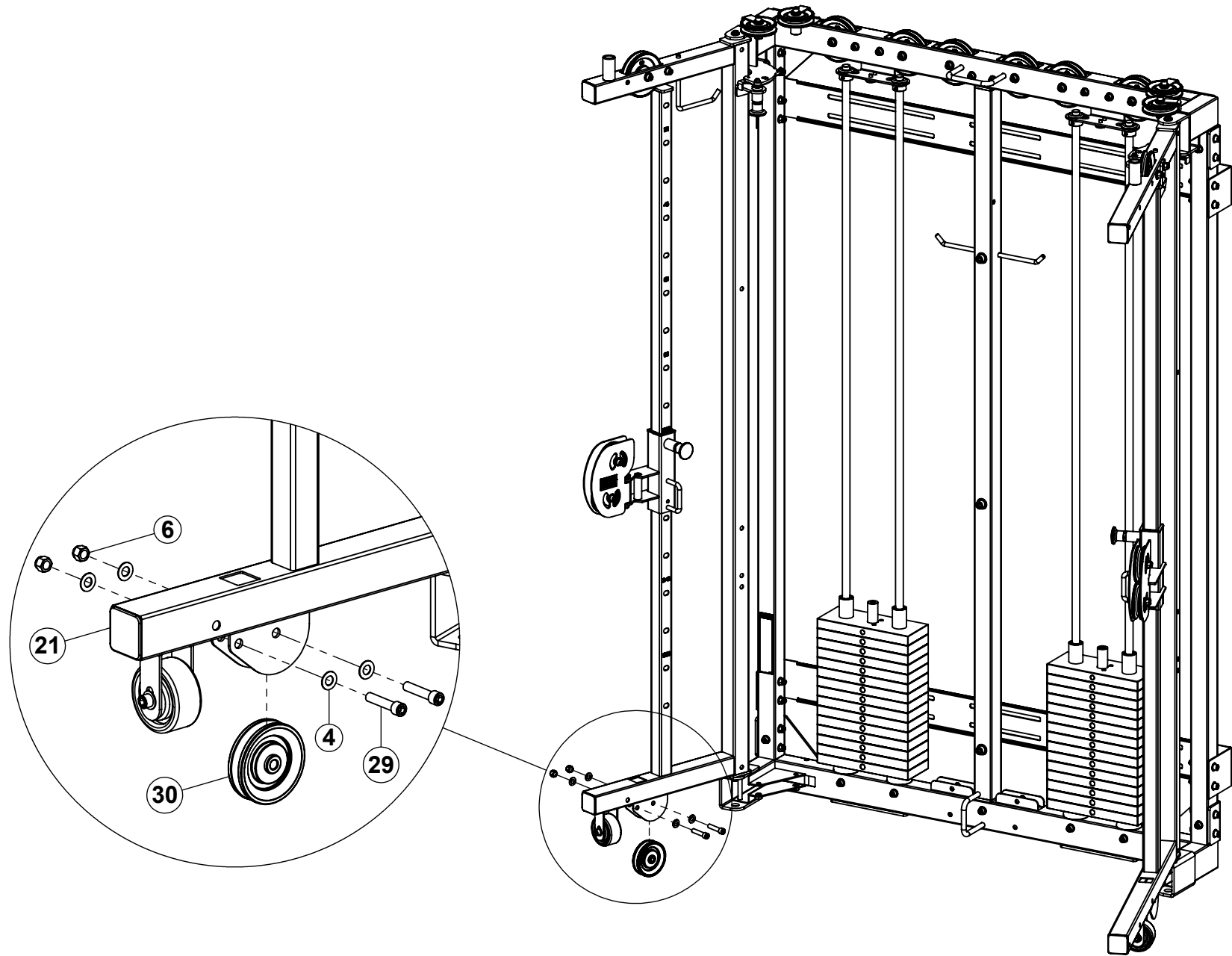

NOTE:
SECURELY tighten bolt connections in this step.

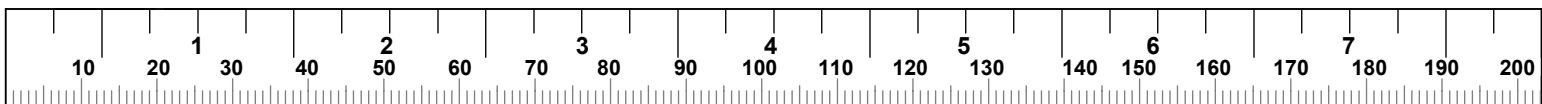

STEP 19

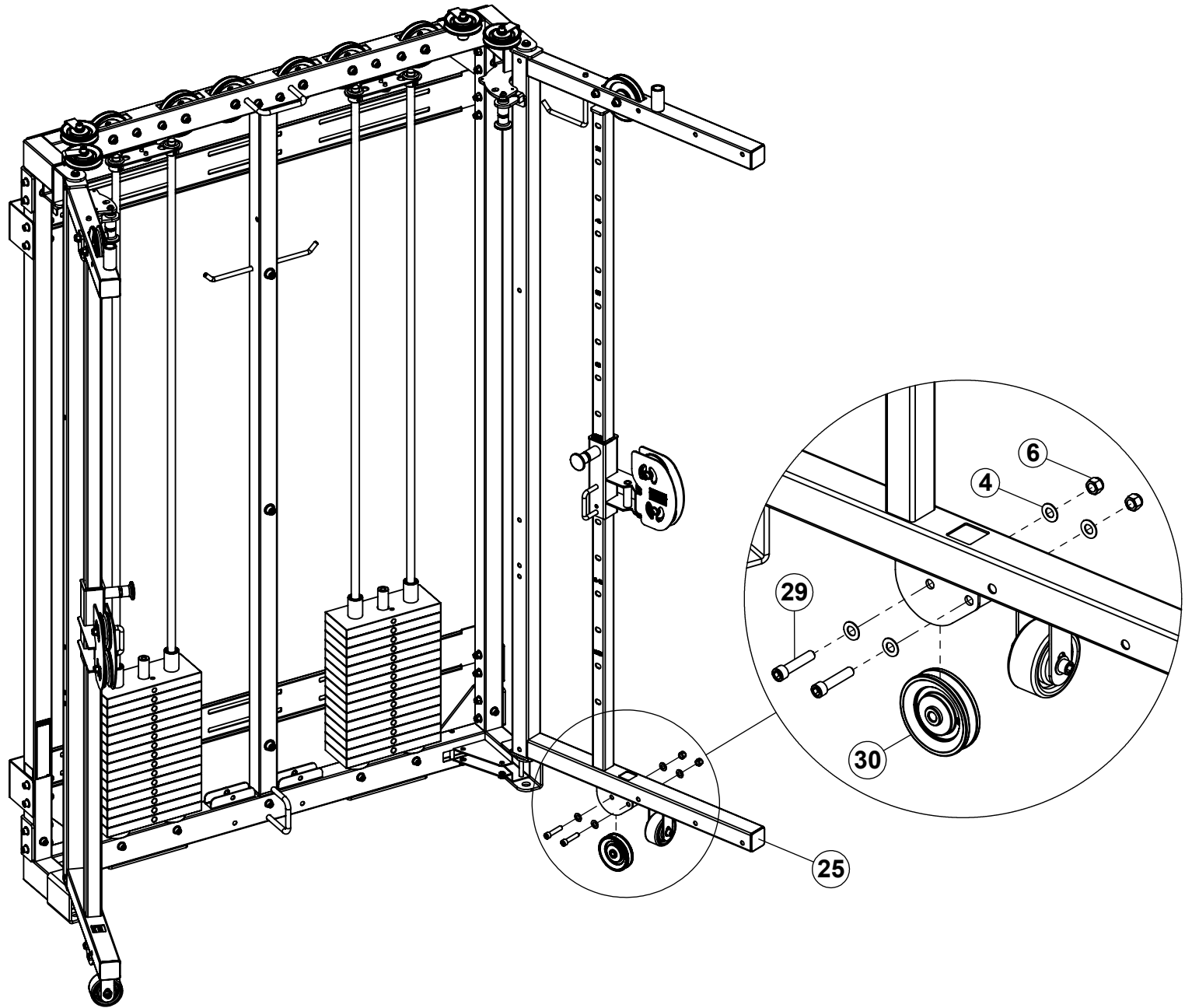

NOTE:
SECURELY tighten bolt connections in this step.

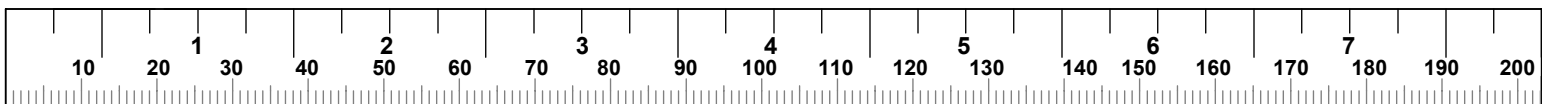

STEP 20

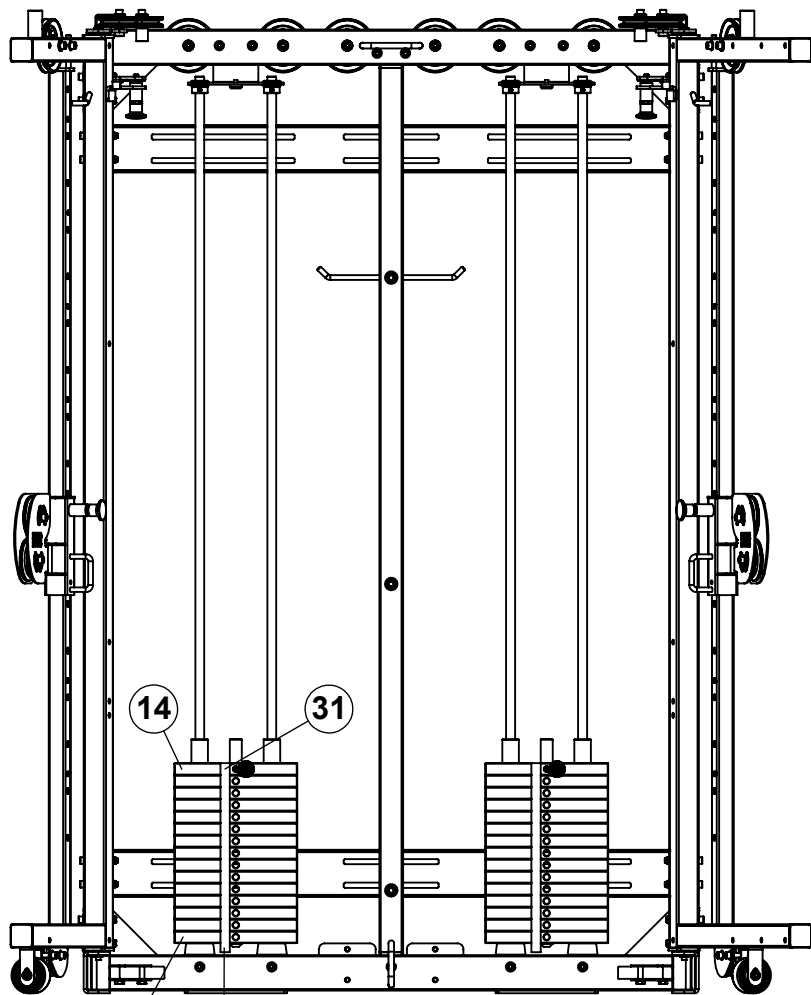

13 12

NOTE:
Apply the WEIGHT STACK LABELS to the left of the holes on WEIGHT PLATES by following the installation instructions printed on the LABEL

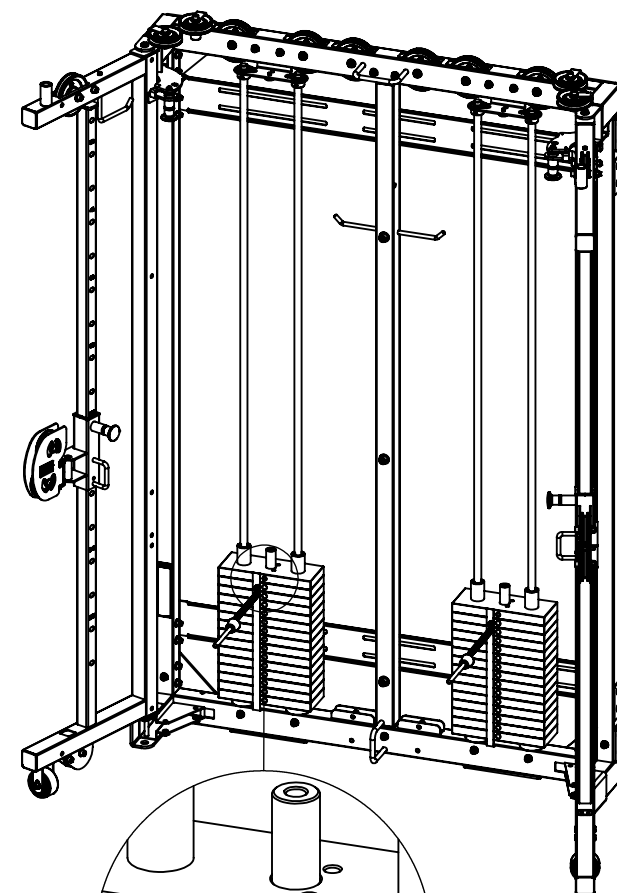

32

14

NOTE:
After WEIGHT STACK LABELS have been applied, use a rubber mallet to carefully install INSERT PLUG of the WEIGHT STACK PIN into the center hole of the HEAD PLATE

STEP 21

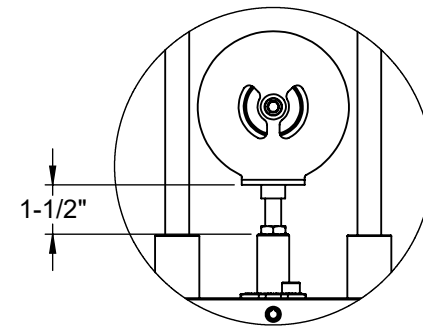
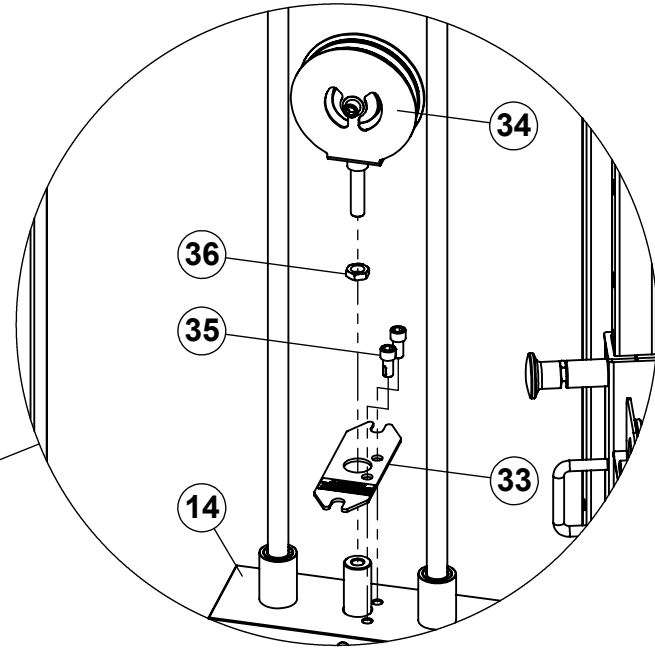
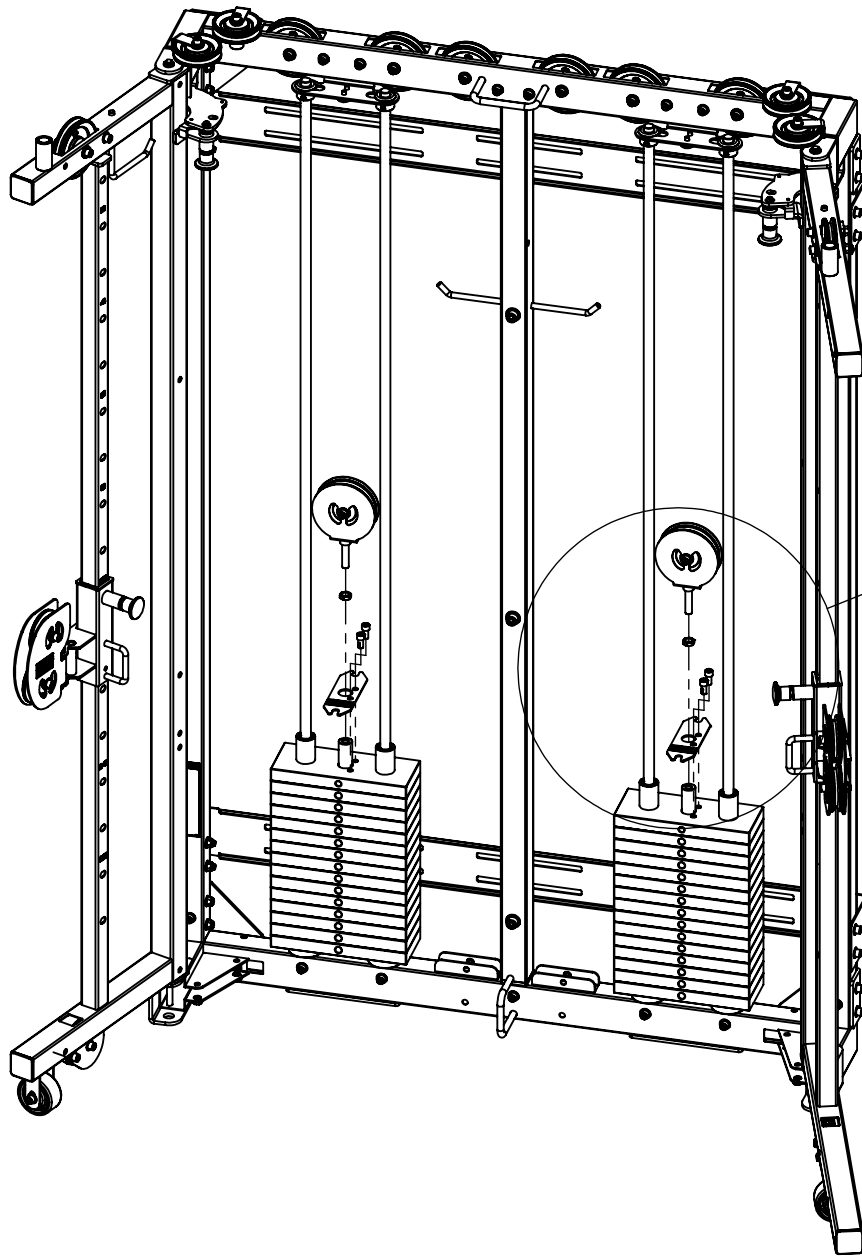

ASSEMBLED VIEW

NOTE:
SECURELY tighten bolt connections in this step.

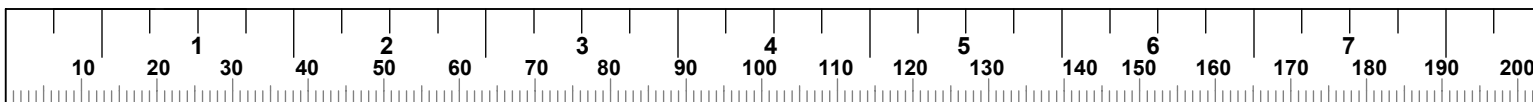

STEP 22 (RIGHT CABLE ASSEMBLY)

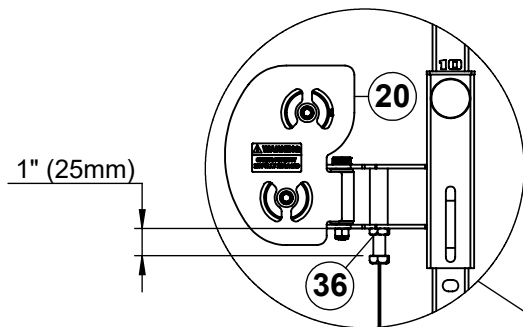

STEP 22a:

Thread a JAM NUT on bolt end of CABLE. Thread bolt end of CABLE into CARRIAGE as shown in inset above.

Route CABLE in direction of arrows. See **CAUTIONS** below.

STEP 22b:

Route ball end of CABLE through DOOR and around PULLEYS. Make sure CABLE is in groove of PULLEY

NOTE 1:

Make sure CABLE runs in front of retaining pins

STEP 22c:

Route ball end of CABLE through BASE and out in front of MIDDLE UPRIGHT

CAUTION:

Make sure CABLE is routed under frame bolts.

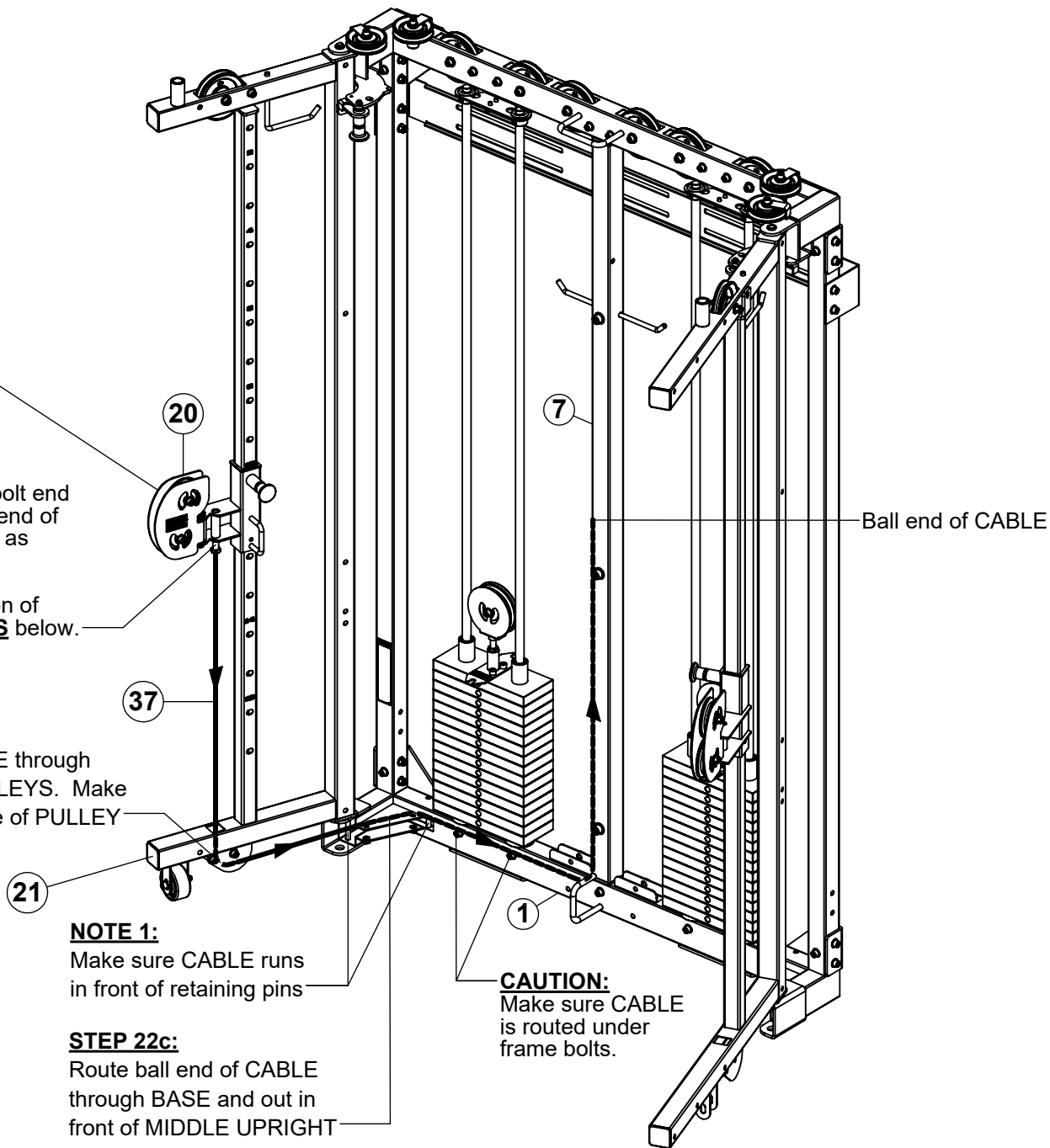

CAUTION:

When routing CABLE, make sure CABLE is seated in groove of PULLEYS and underneath all retaining bolts, pins or brackets. Failure to do so, may result in damage to CABLE.

STEP 23 (RIGHT CABLE ASSEMBLY)

STEP 23c

Route CABLE around these four PULLEYS

STEP 23a

Route CABLE around these two PULLEYS

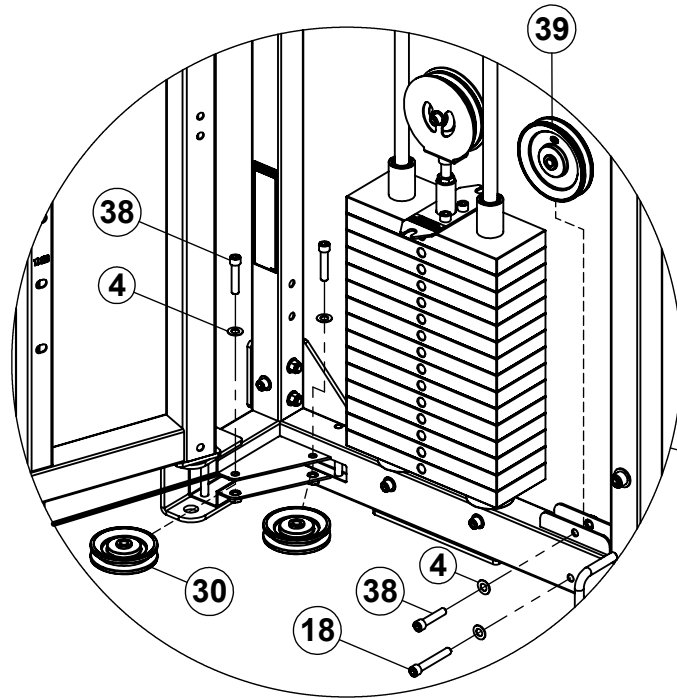

STEP 23d
Route CABLE around pulley

Ball end of CABLE

STEP 23b
Route CABLE around PULLEY

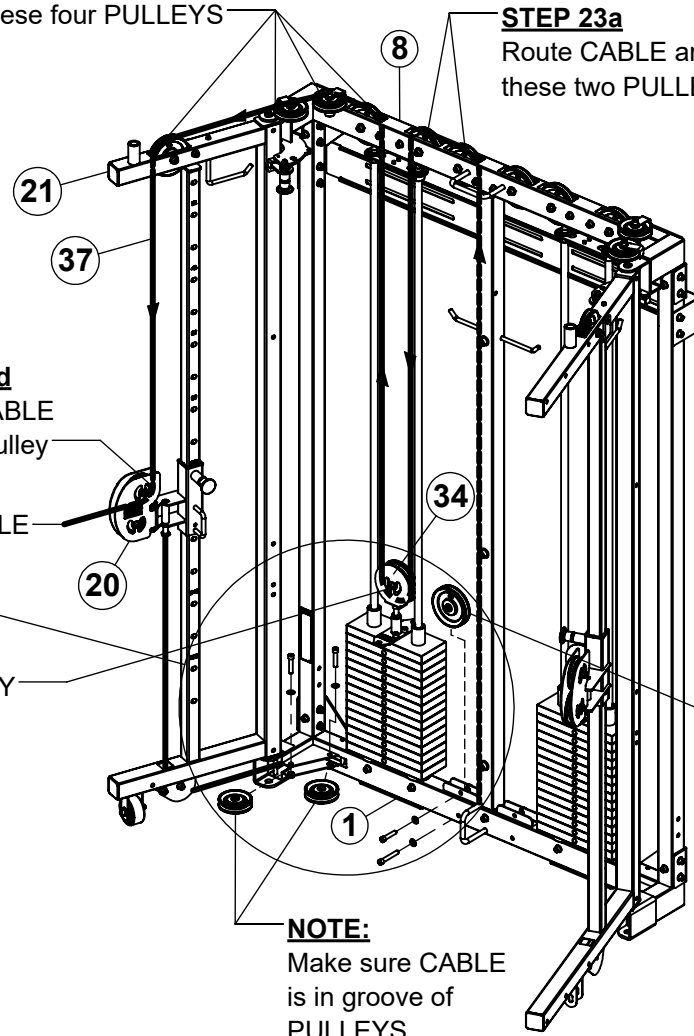

NOTE:
Make sure CABLE is in groove of PULLEY

NOTE:
Make sure CABLE is in groove of PULLEYS

CAUTION:

When routing CABLE, make sure CABLE is seated in groove of PULLEYS and underneath all retaining bolts, pins or brackets. Failure to do so, may result in damage to CABLE.

NOTE:

SECURELY tighten bolt connections in this step.

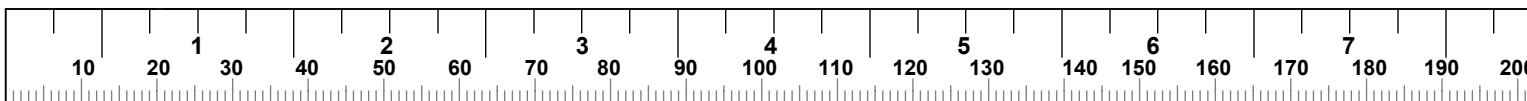

STEP 24A (RIGHT CABLE ASSEMBLY)

4) Slide 40 over 41 & 42
then assemble 43 to 42

1) Slide 40 over
CABLE end

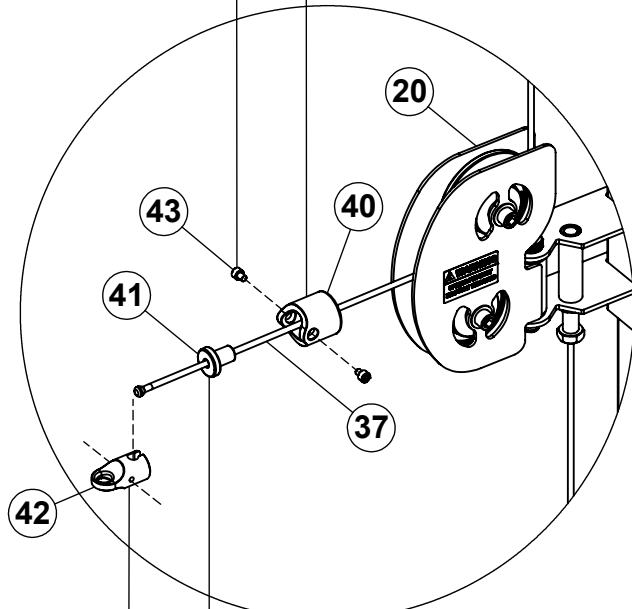

2) Slide 41 over
CABLE end

3) Slide 42 on to
CABLE end

NOTE:

Before beginning this step, lift HEAD PLATE up and insert WEIGHT STACK PIN into bottom hole of stem and set back down on top of first WEIGHT PLATE

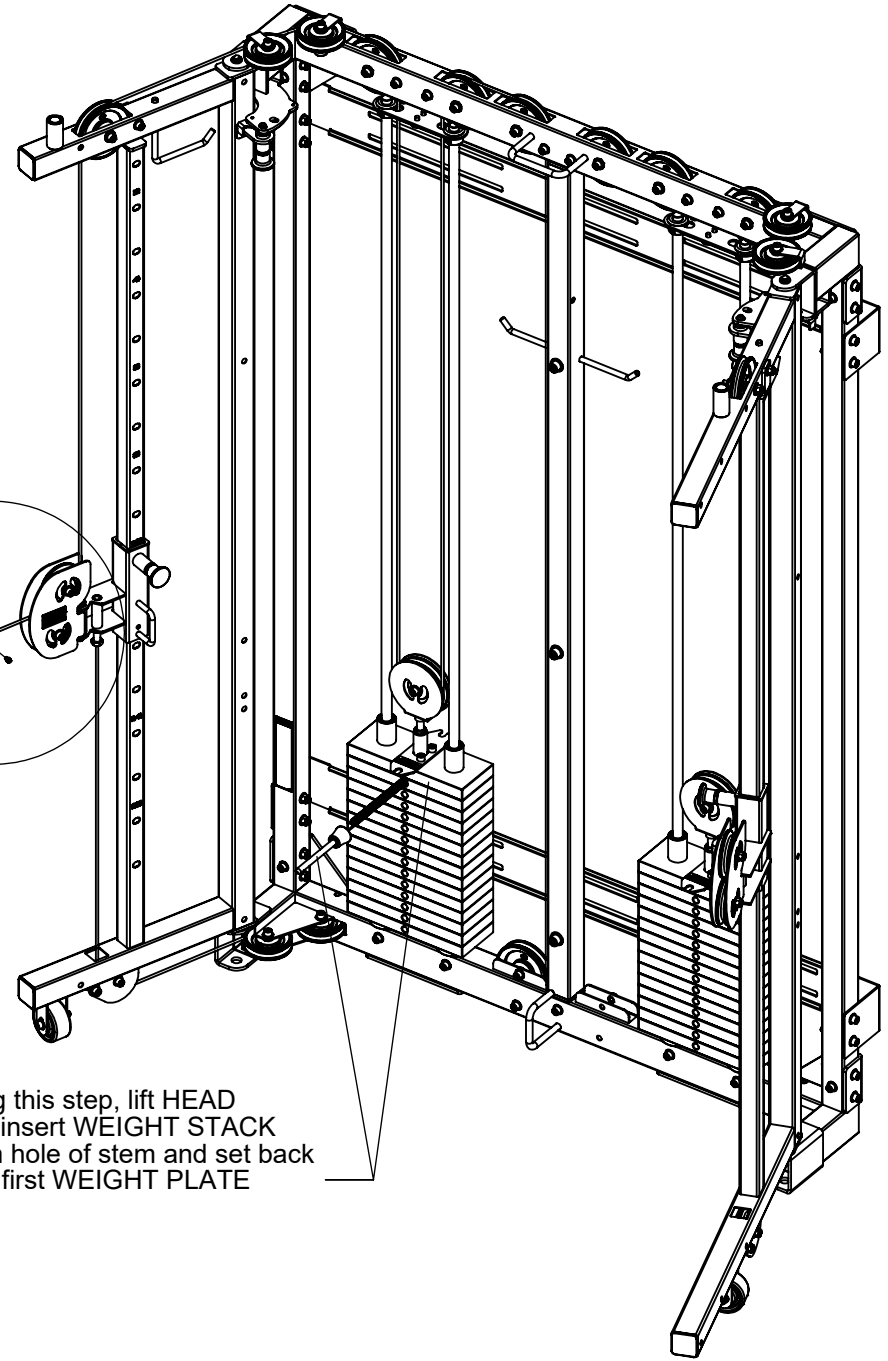

NOTE:
SECURELY tighten bolt connections in this step.

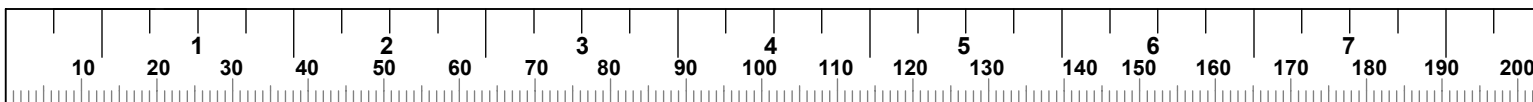

STEP 24B (RIGHT CABLE ADJUSTMENT)

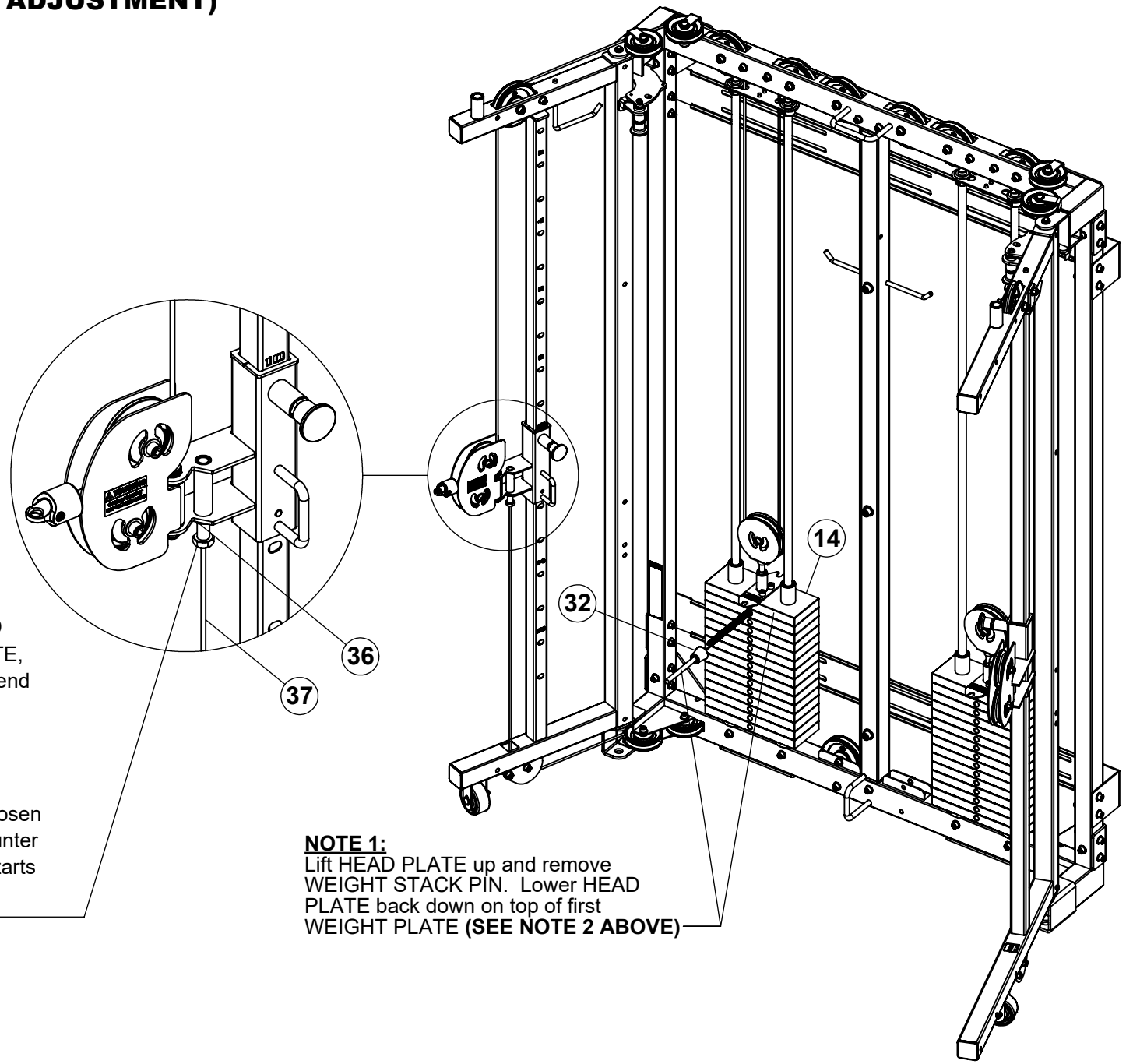

NOTE 2:

If there is a gap between HEAD PLATE and first WEIGHT PLATE, loosen JAM NUT and turn bolt end clockwise until HEAD PLATE touches first WEIGHT PLATE.

SECURELY tighten JAM NUT.

If CABLE has too much slack, loosen JAM NUT and turn bolt end counter clockwise until HEAD PLATE starts lifting off first WEIGHT PLATE.

SECURELY tighten JAM NUT.

NOTE 1:

Lift HEAD PLATE up and remove WEIGHT STACK PIN. Lower HEAD PLATE back down on top of first WEIGHT PLATE (**SEE NOTE 2 ABOVE**)

NOTE:

SECURELY tighten bolt connections in this step.

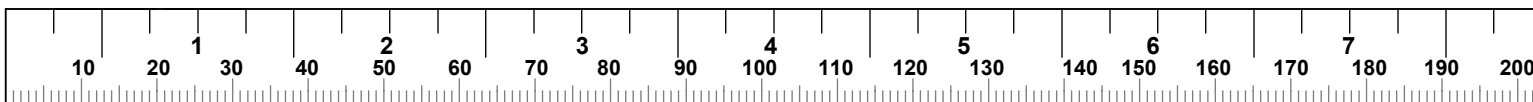

STEP 25 (LEFT CABLE ASSEMBLY)

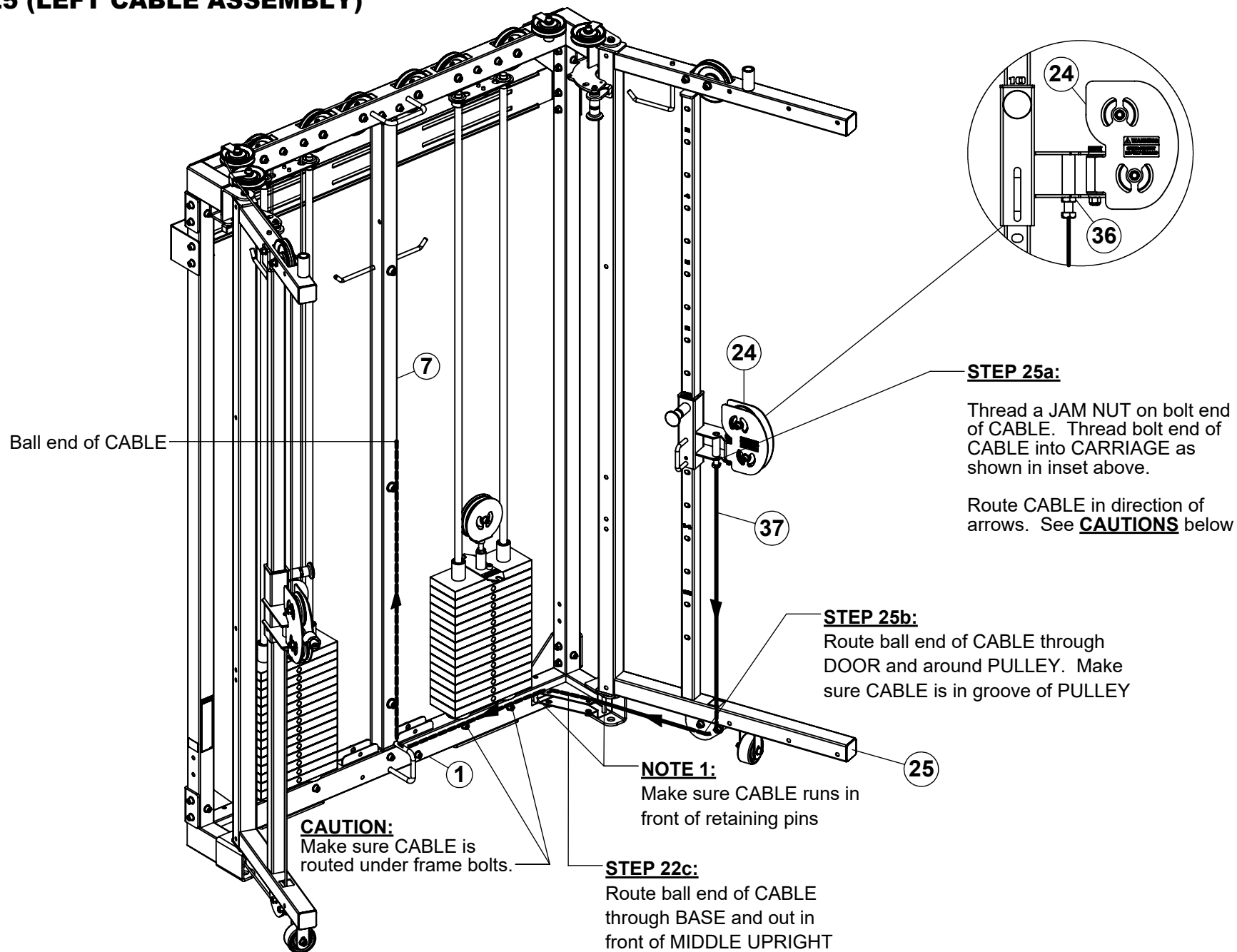

CAUTION:

When routing CABLE, make sure CABLE is seated in groove of PULLEYS and underneath all retaining bolts, pins or brackets. Failure to do so, may result in damage to CABLE.

STEP 26 (LEFT CABLE ASSEMBLY)

STEP 26a

Route CABLE over these two PULLEYS

STEP 26c

Route CABLE around these four PULLEYS

STEP 26d

Route CABLE around PULLEY

STEP 26b

Route CABLE around PULLEY

NOTE:

Make sure CABLE is in groove of PULLEYS

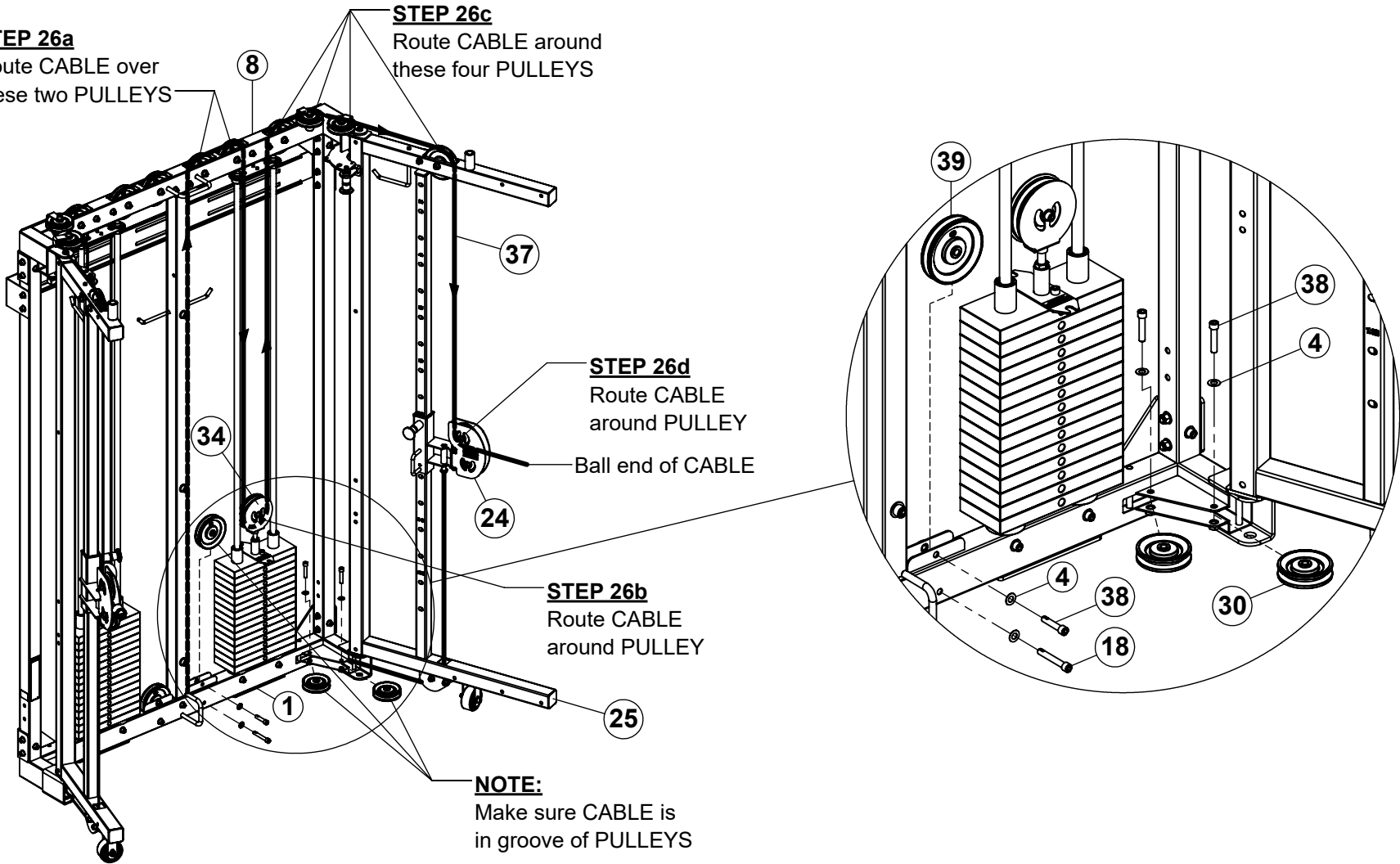

CAUTION:

When routing CABLE, make sure CABLE is seated in groove of PULLEYS and underneath all retaining bolts, pins or brackets. Failure to do so, may result in damage to CABLE.

NOTE:

SECURELY tighten bolt connections in this step.

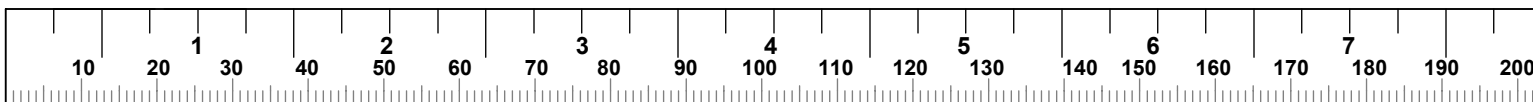

STEP 27A (LEFT CABLE ASSEMBLY)

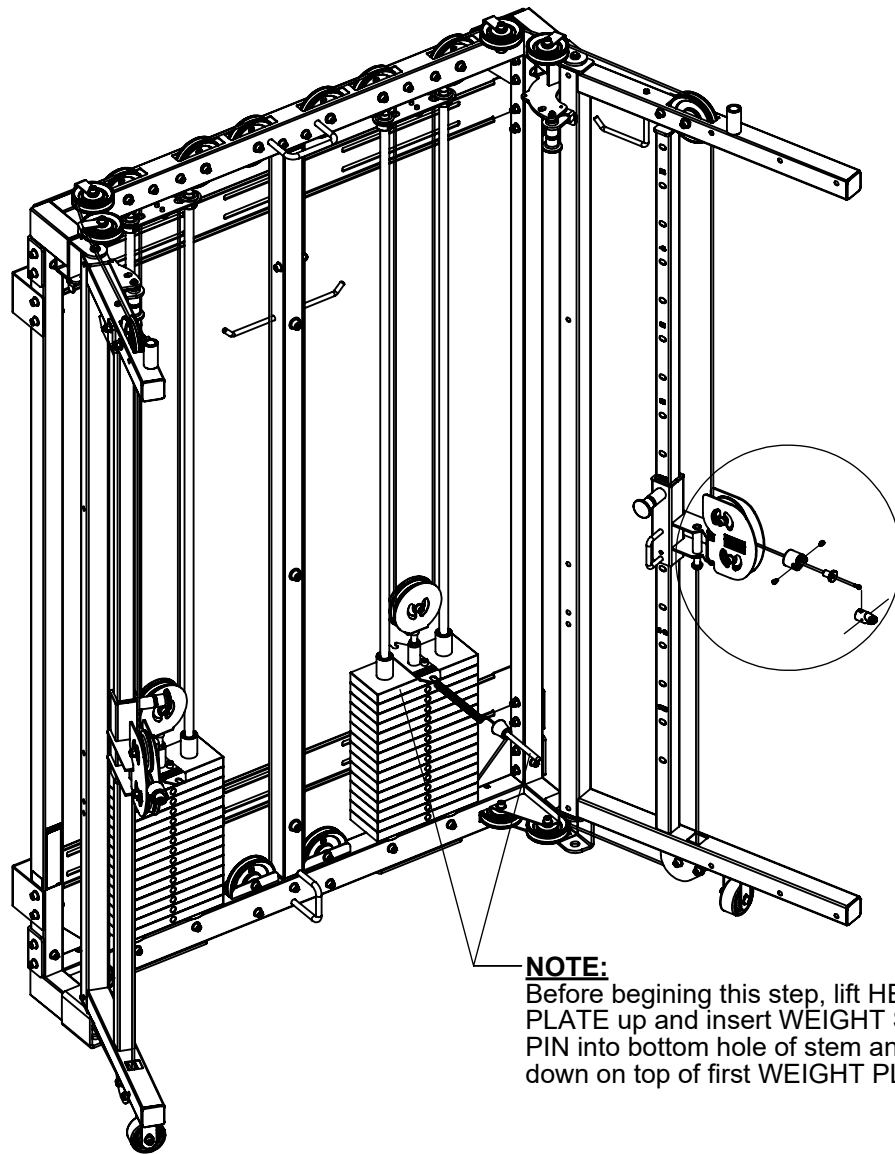

NOTE:
Before beginning this step, lift HEAD PLATE up and insert WEIGHT STACK PIN into bottom hole of stem and set back down on top of first WEIGHT PLATE

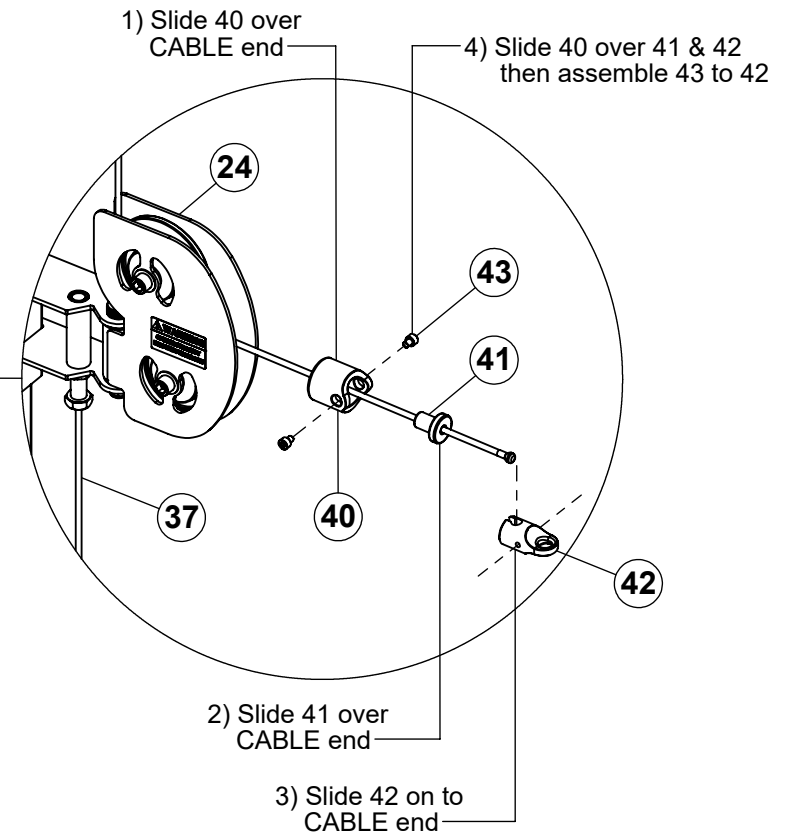

NOTE:
SECURELY tighten bolt connections in this step.

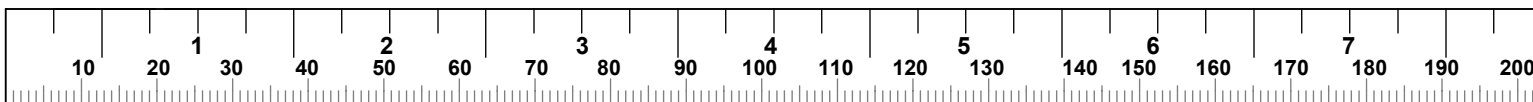

STEP 27B (LEFT CABLE ADJUSTMENT)

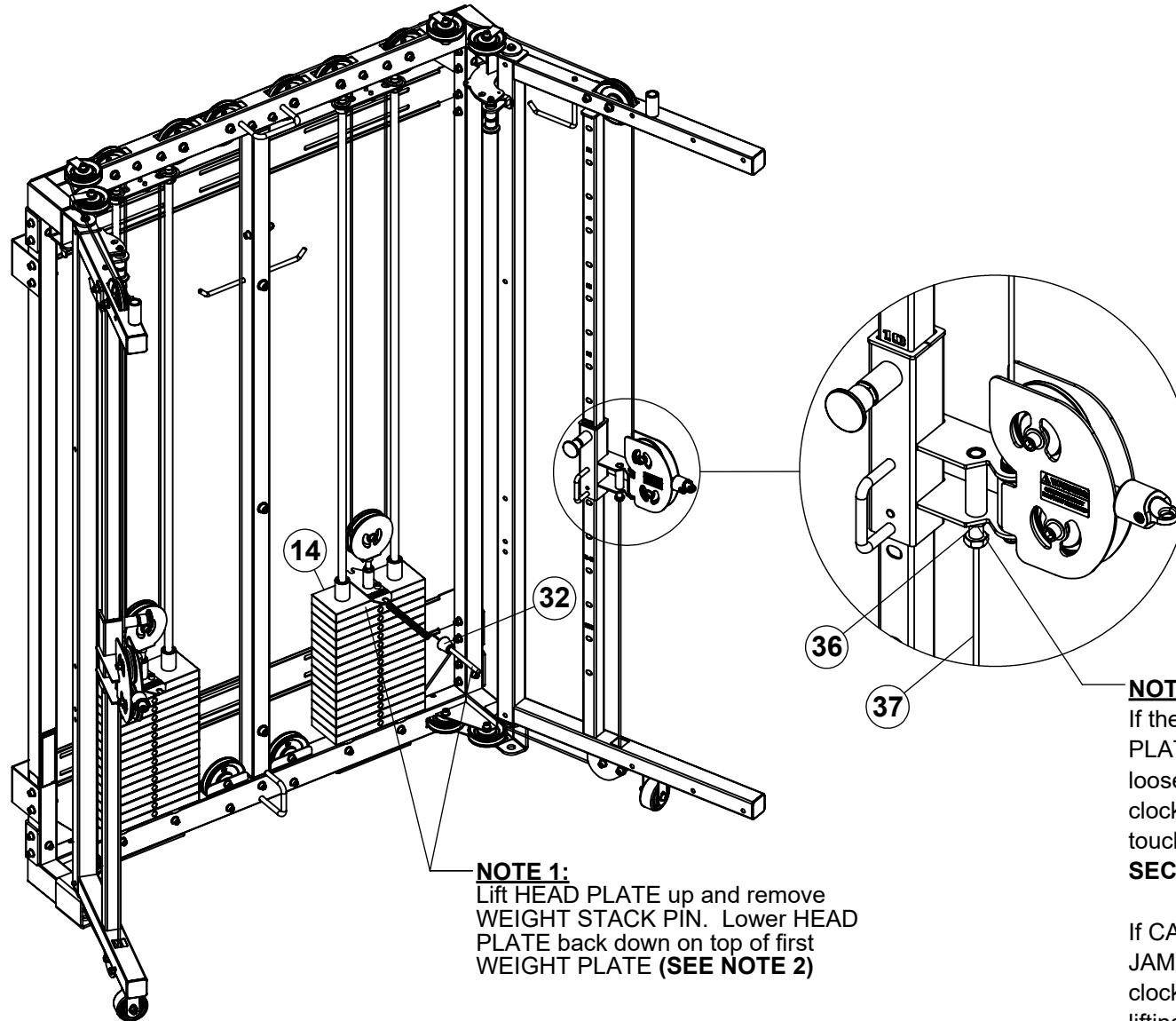

NOTE 1:
Lift HEAD PLATE up and remove WEIGHT STACK PIN. Lower HEAD PLATE back down on top of first WEIGHT PLATE (SEE NOTE 2)

NOTE 2:

If there is a gap between HEAD PLATE and first WEIGHT PLATE, loosen JAM NUT and turn bolt end clockwise until HEAD PLATE touches first WEIGHT PLATE. **SECURELY** tighten JAM NUT.

If CABLE has too much slack, loosen JAM NUT and turn bolt end counter clockwise until HEAD PLATE starts lifting off first WEIGHT PLATE. **SECURELY** tighten JAM NUT.

NOTE:
SECURELY tighten bolt connections in this step.

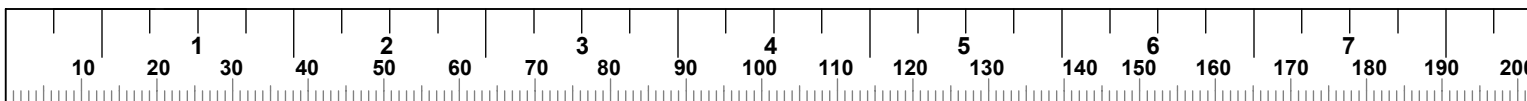

STEP 28

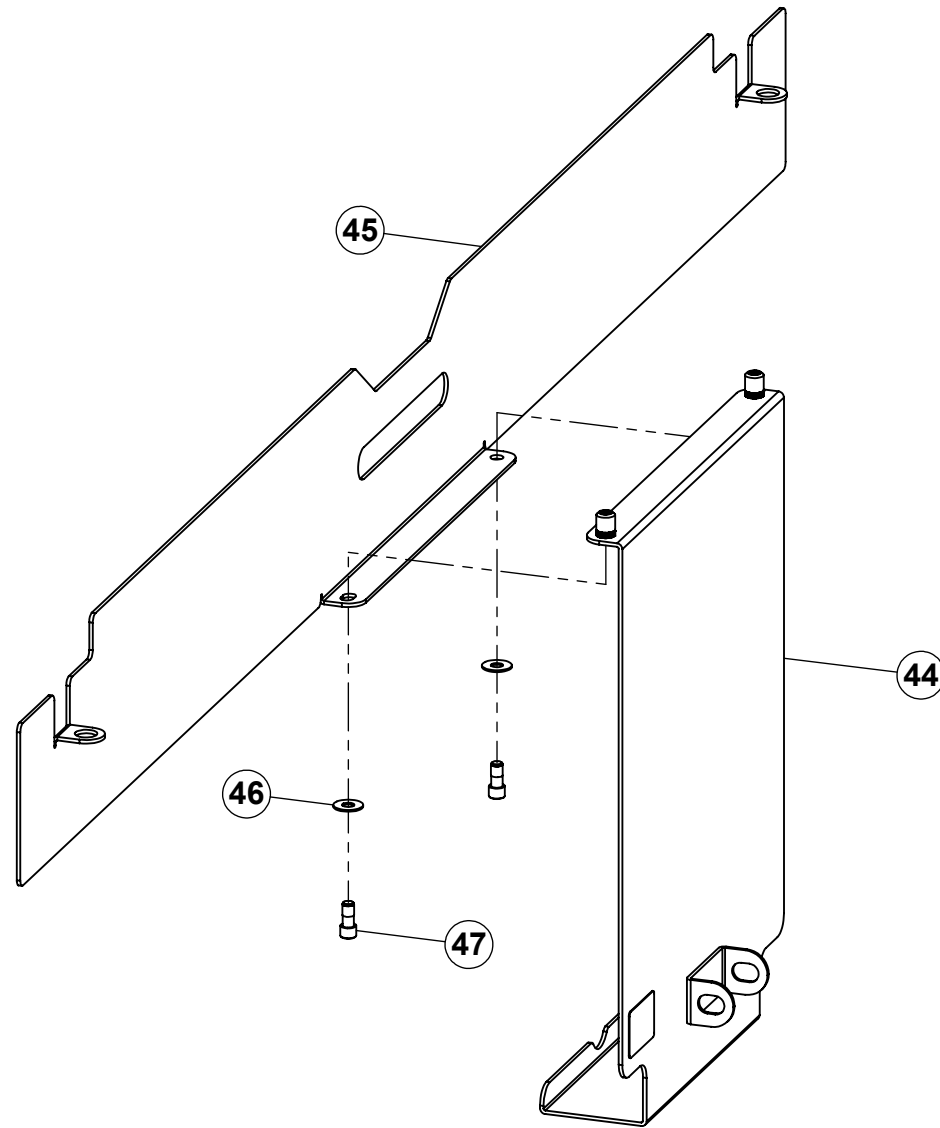

NOTE:
SECURELY tighten bolt connections in this step.

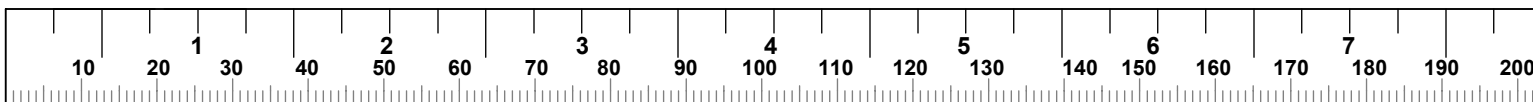

STEP 29

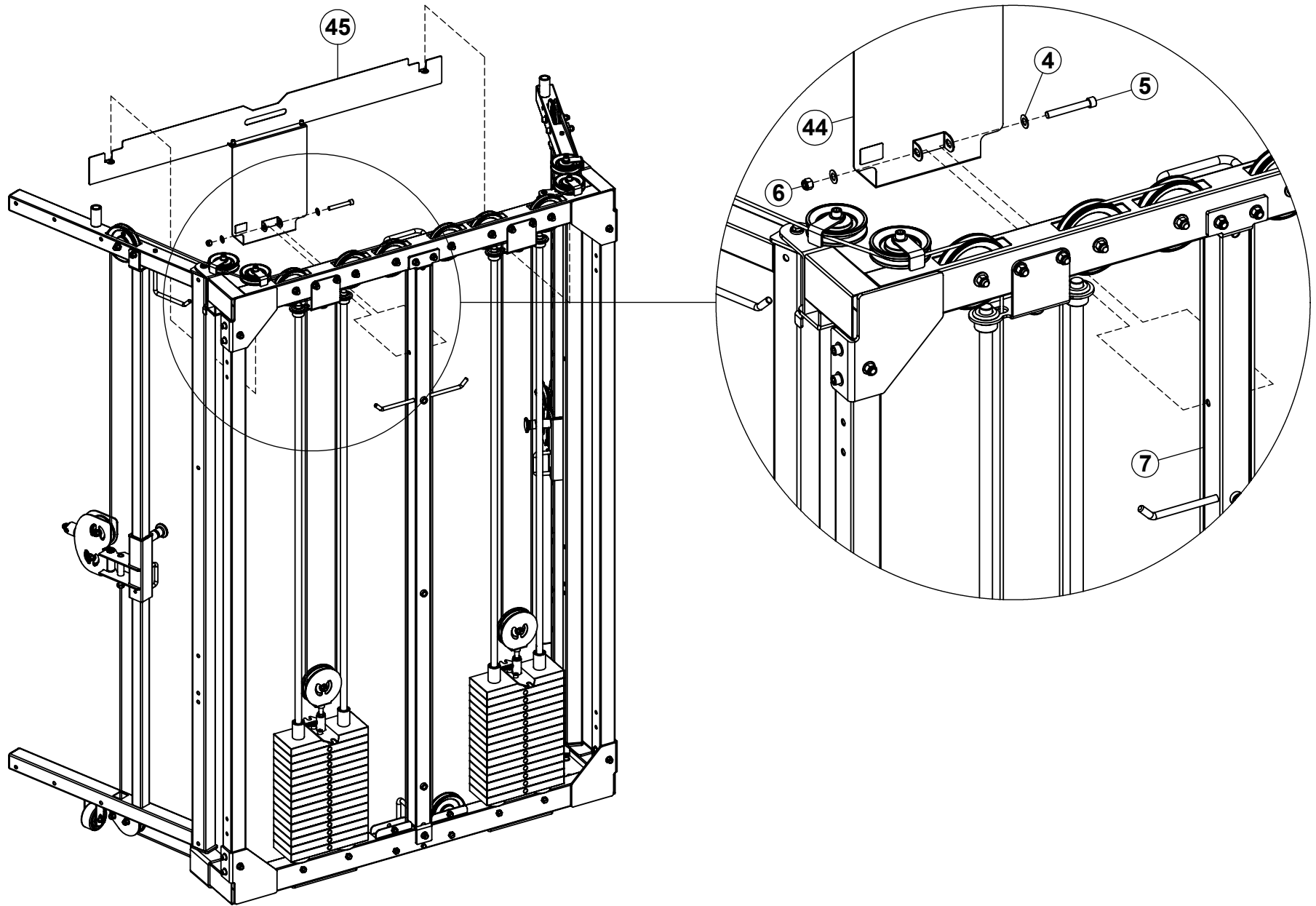

NOTE:
LOOSELY tighten bolt connections in this step.

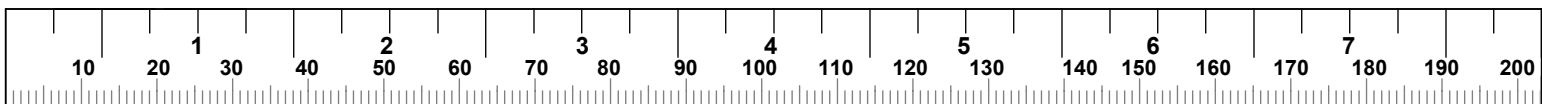

STEP 30

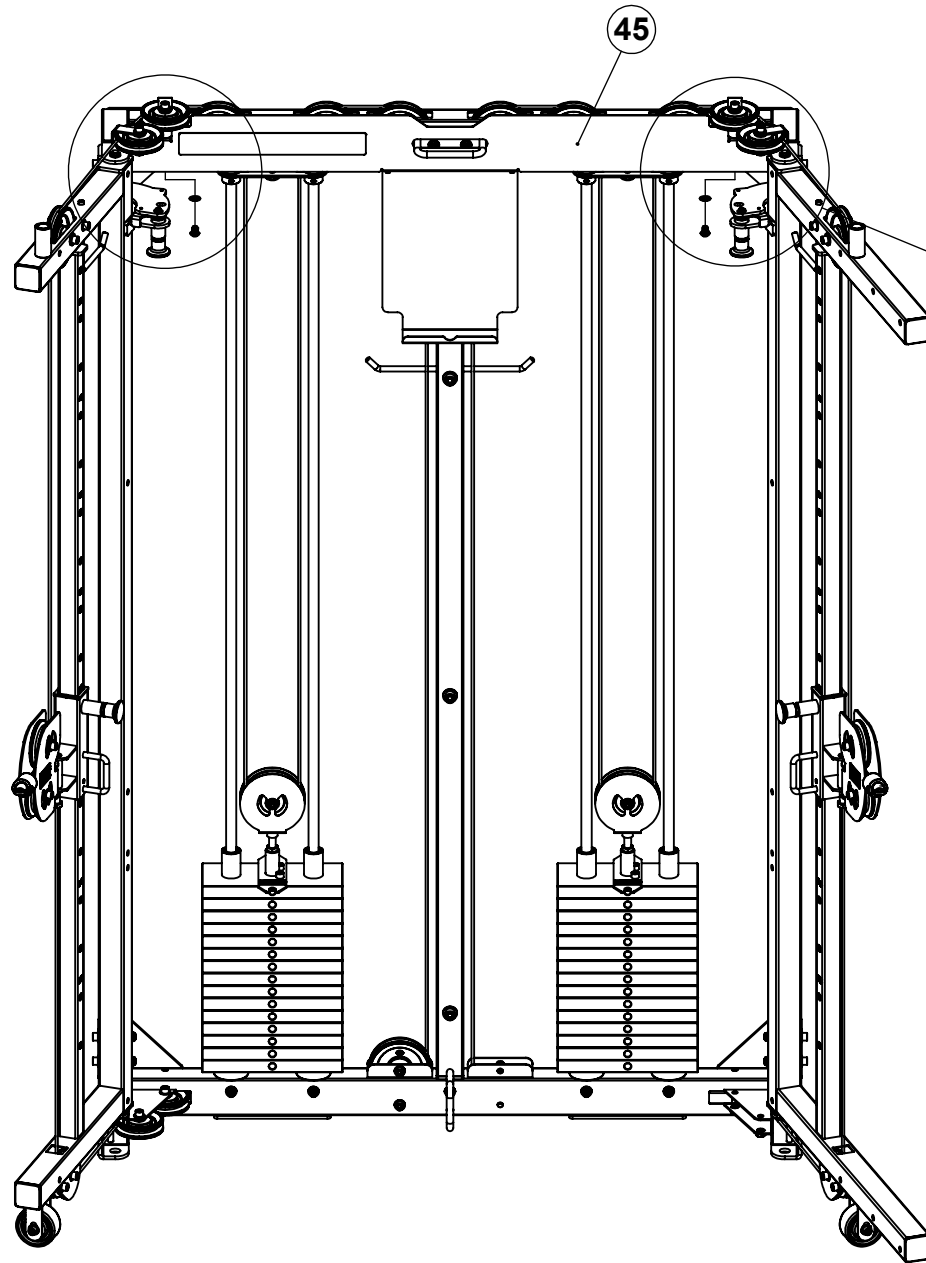

NOTE:
Assemble TOB BOOM SHROUD to bottom of pulley shaft (2 places).

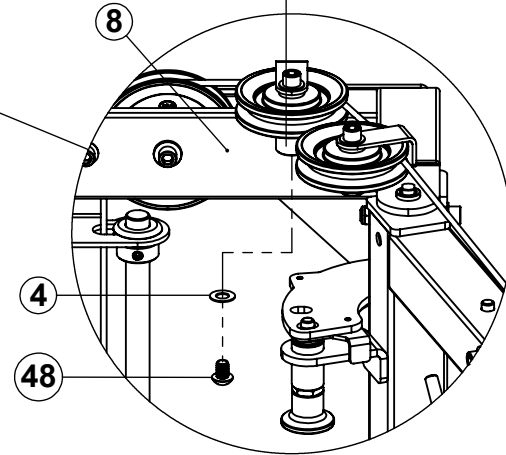

NOTE:
TOP BOOM SHROUD has been hidden for assembly clarity

NOTE:
Once this step has been completed, **SECURELY** tighten all bolt connections in this step and previous step.

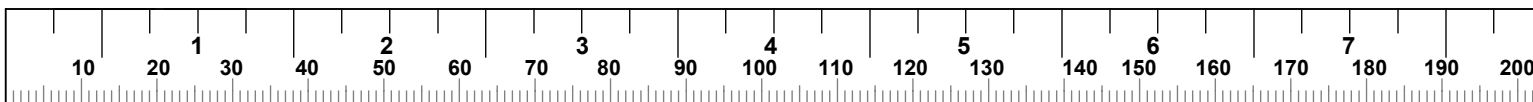

STEP 31

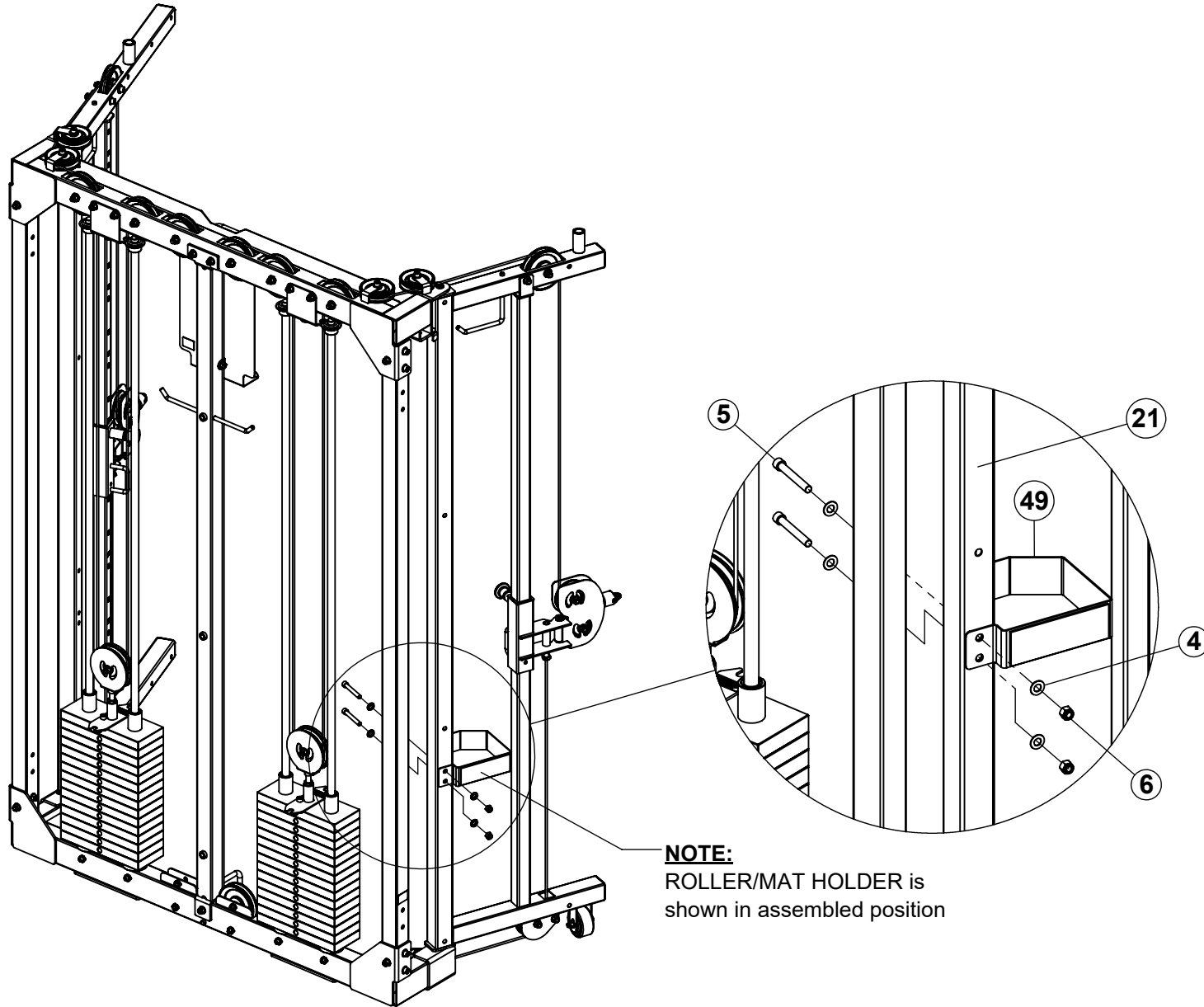

NOTE:
SECURELY tighten bolt connections in this step.

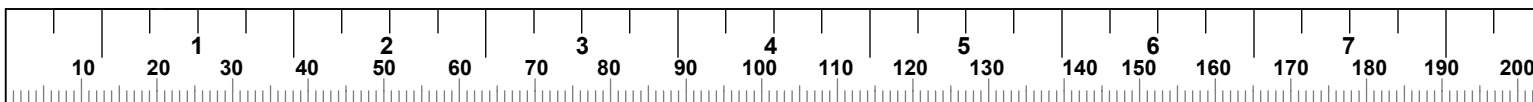

STEP 32

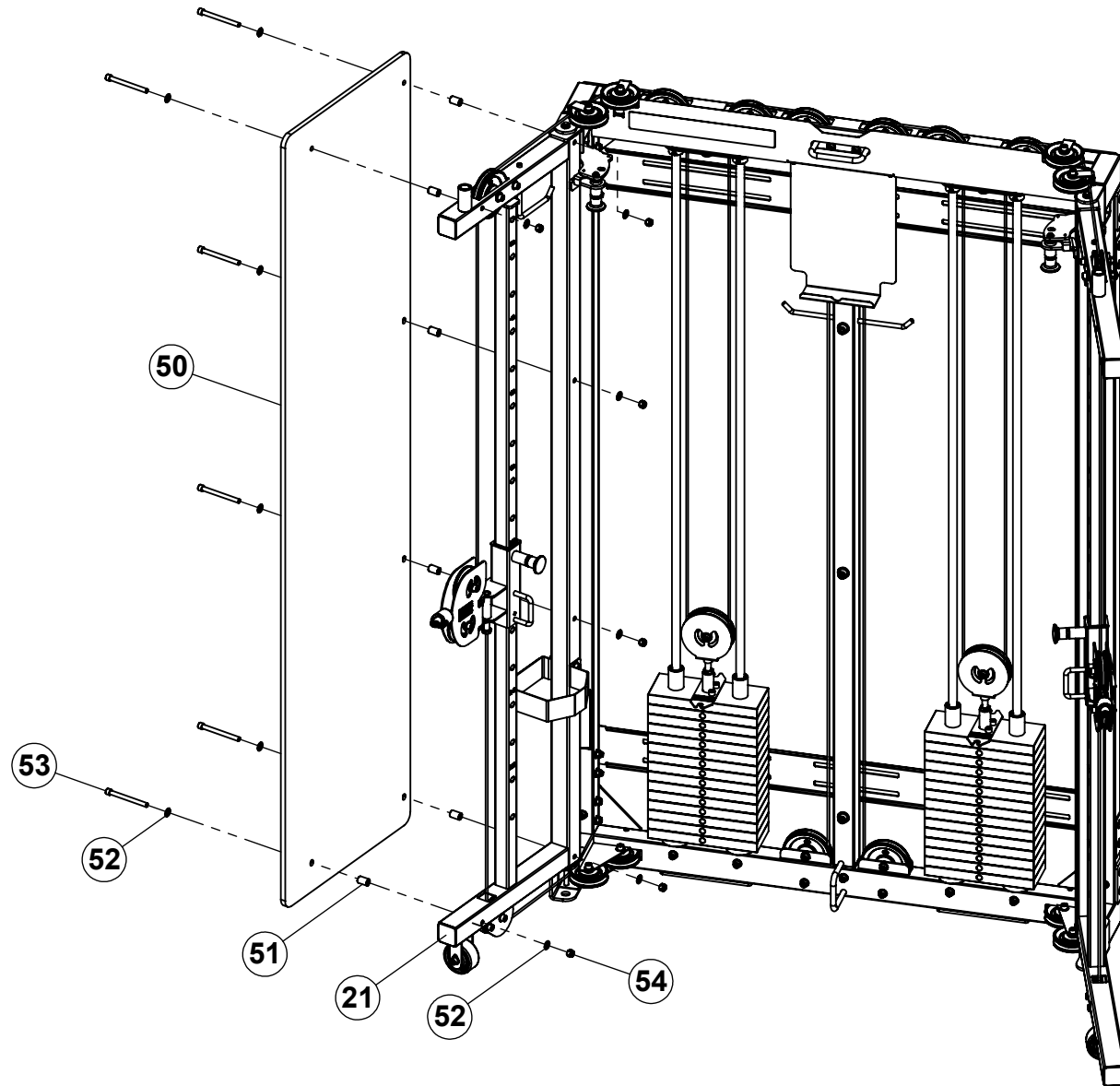

NOTE:
SECURELY tighten bolt connections in this step.

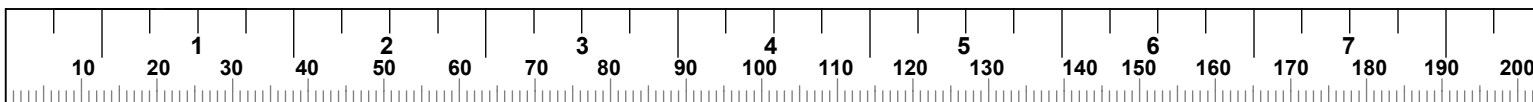

STEP 33

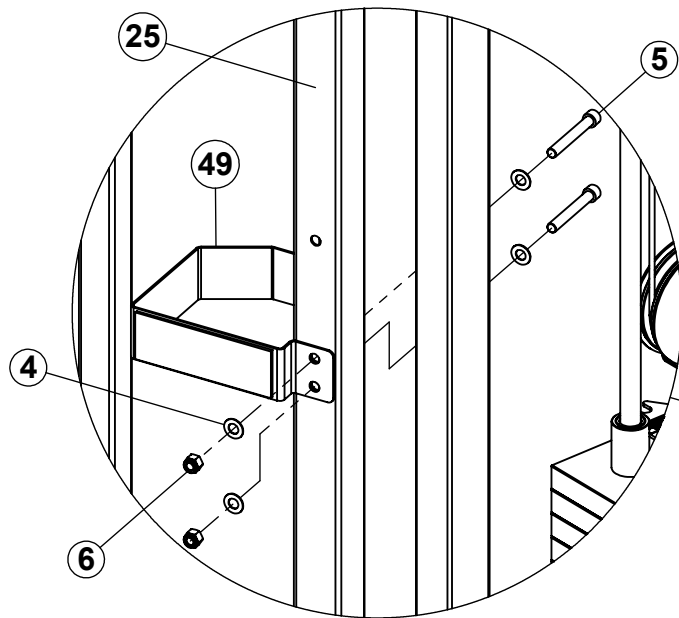

NOTE:
ROLLER/MAT HOLDER is
shown in assembled position

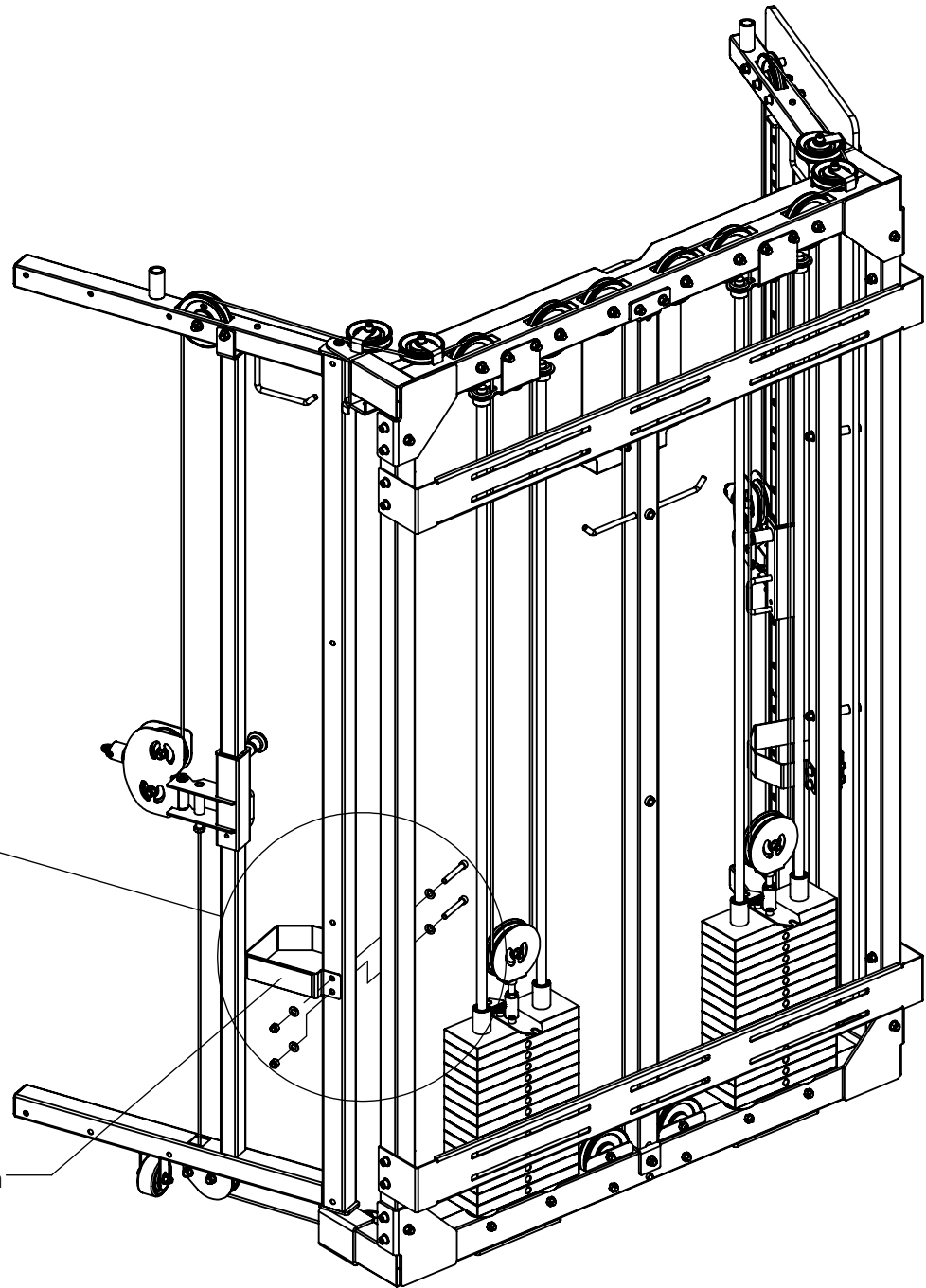

NOTE:
SECURELY tighten bolt connections in this step.

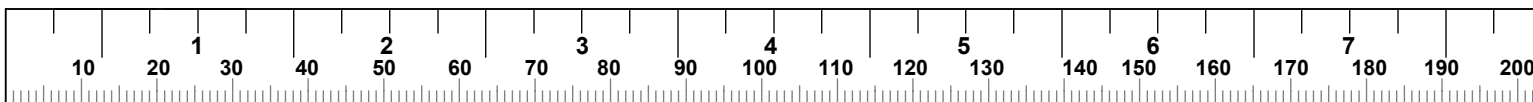

STEP 34

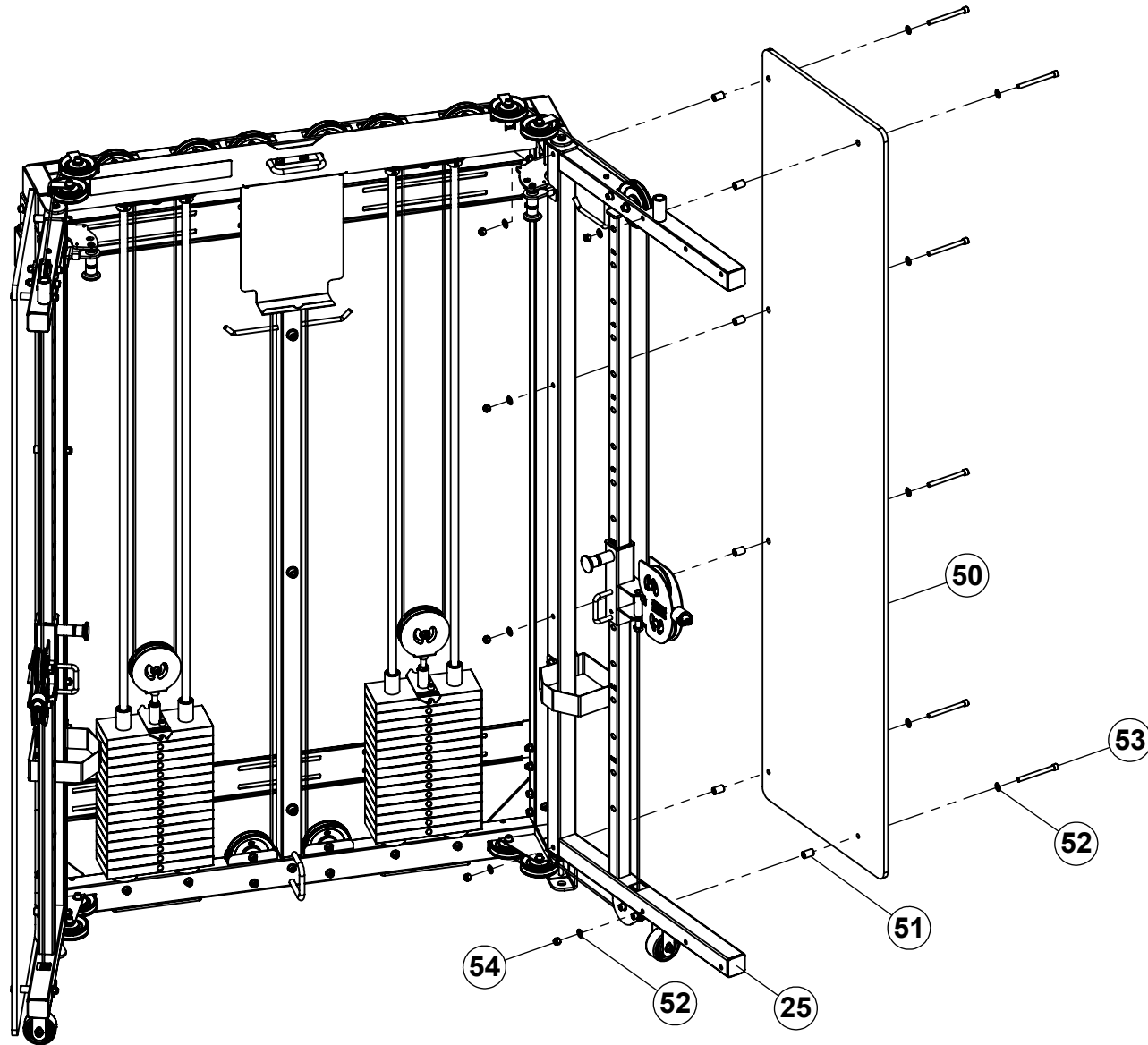

NOTE:
SECURELY tighten bolt connections in this step.

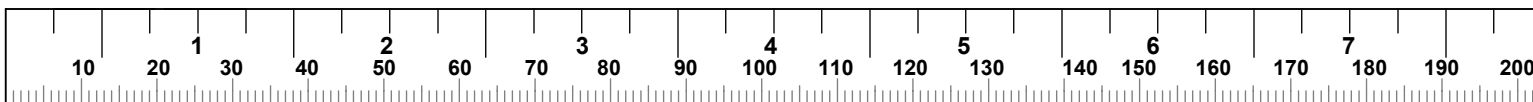

STEP 35

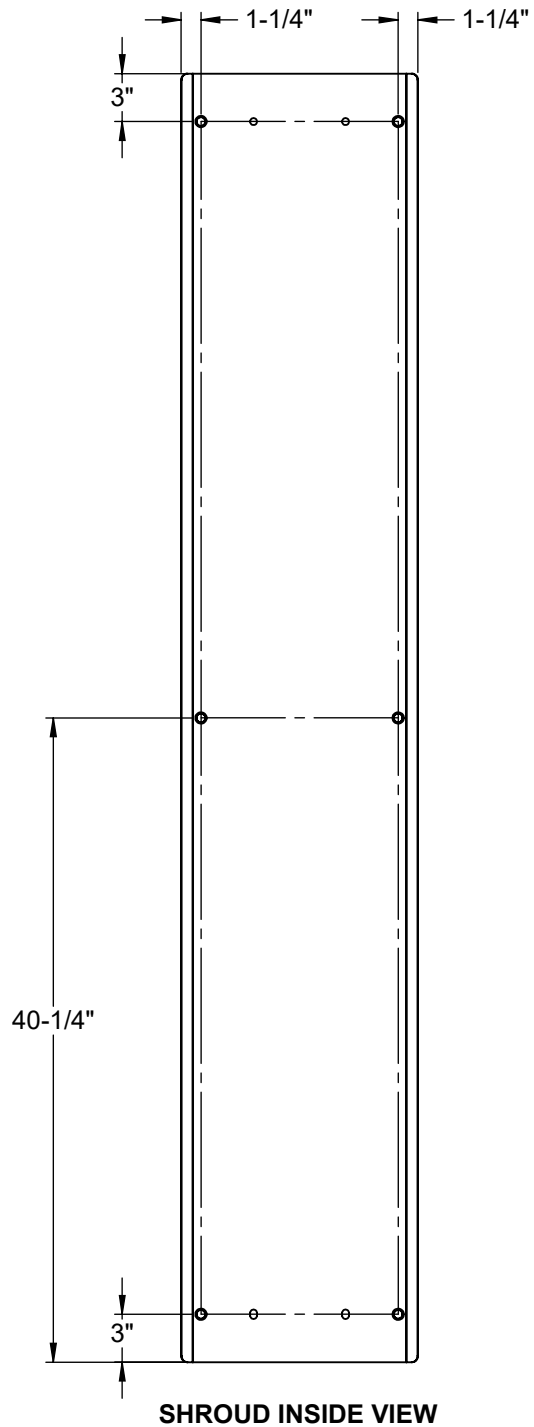

NOTE:
Peel backing from BUMPERS
and stick BUMPER to the inside
surface of FRONT DOOR
SHROUD as shown in INSIDE VIEW

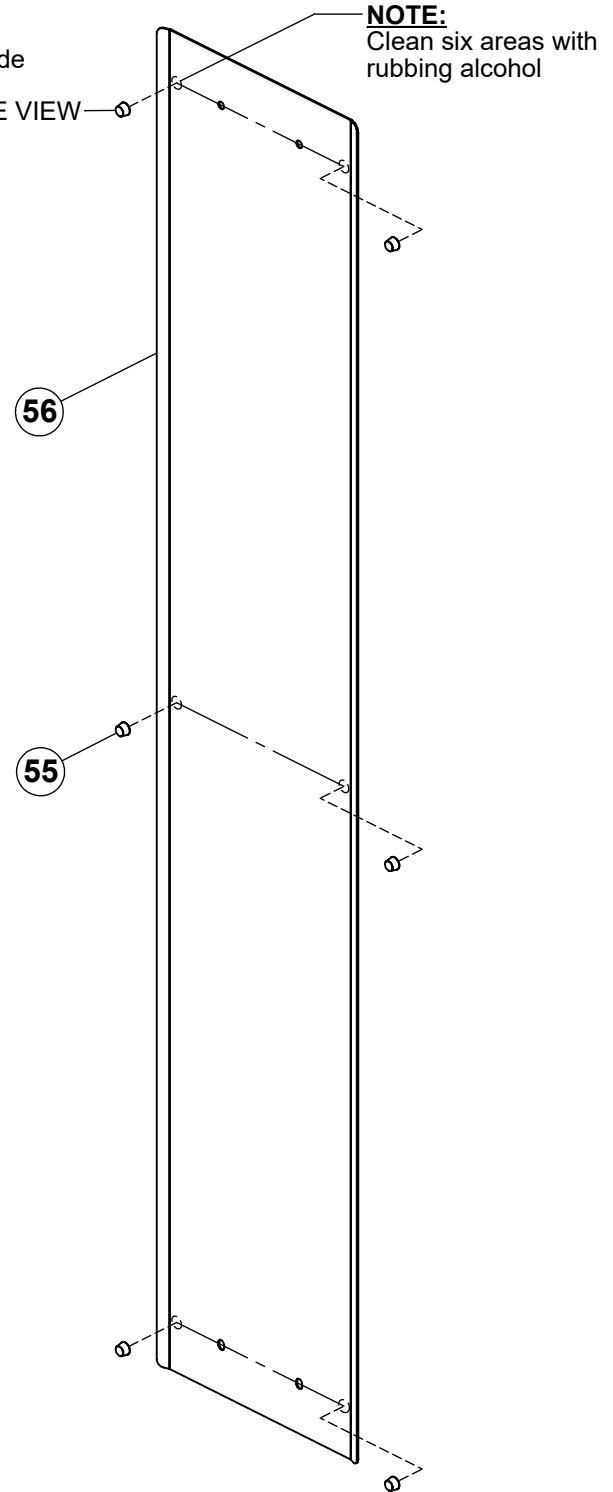

STEP 36

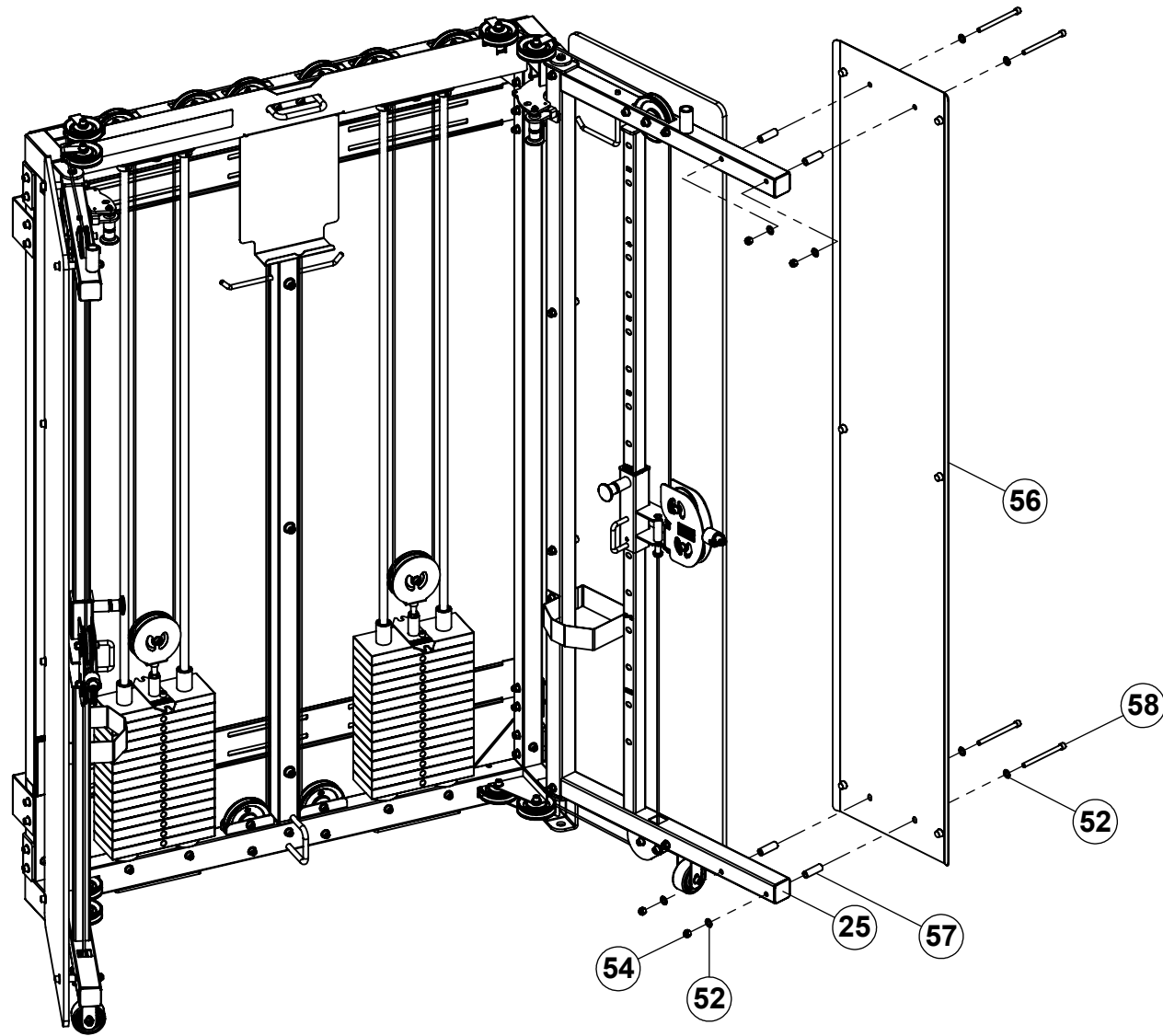

NOTE:
SECURELY tighten bolt connections in this step.

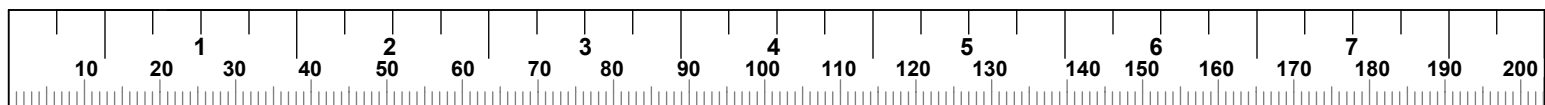

STEP 37

NOTE:
Attach
RESISTANCE
BANDS here

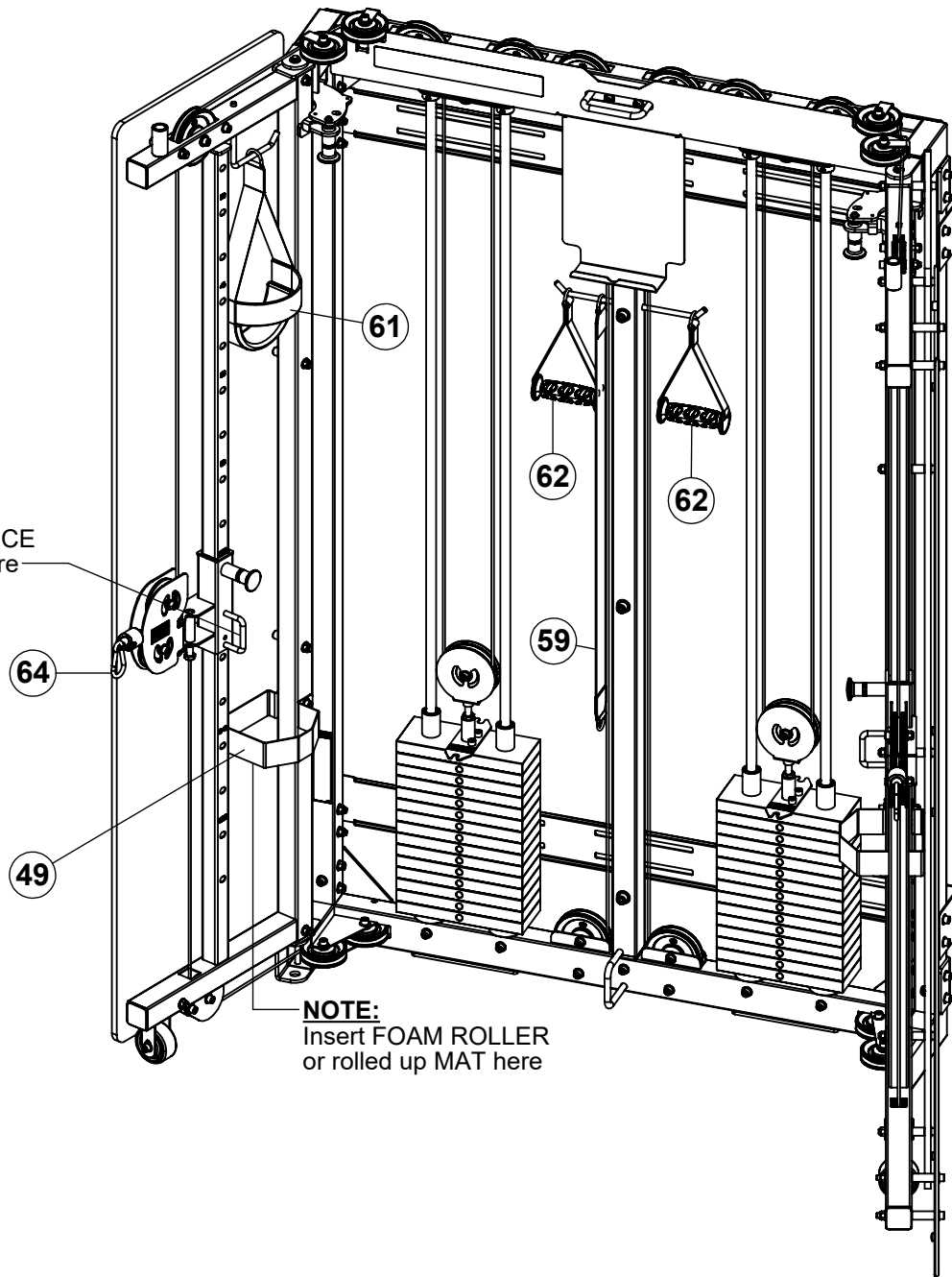

NOTE:
Insert FOAM ROLLER
or rolled up MAT here

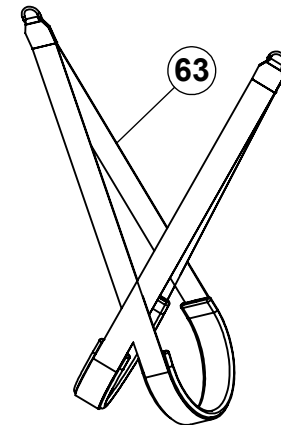

STEP 38

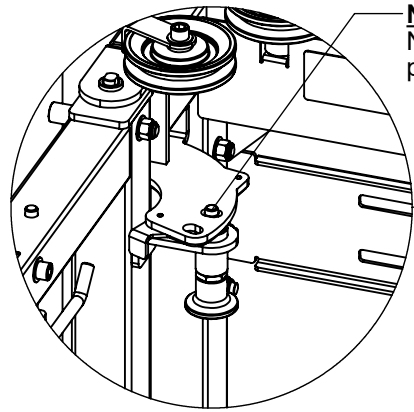

NOTE:
Narrow
position

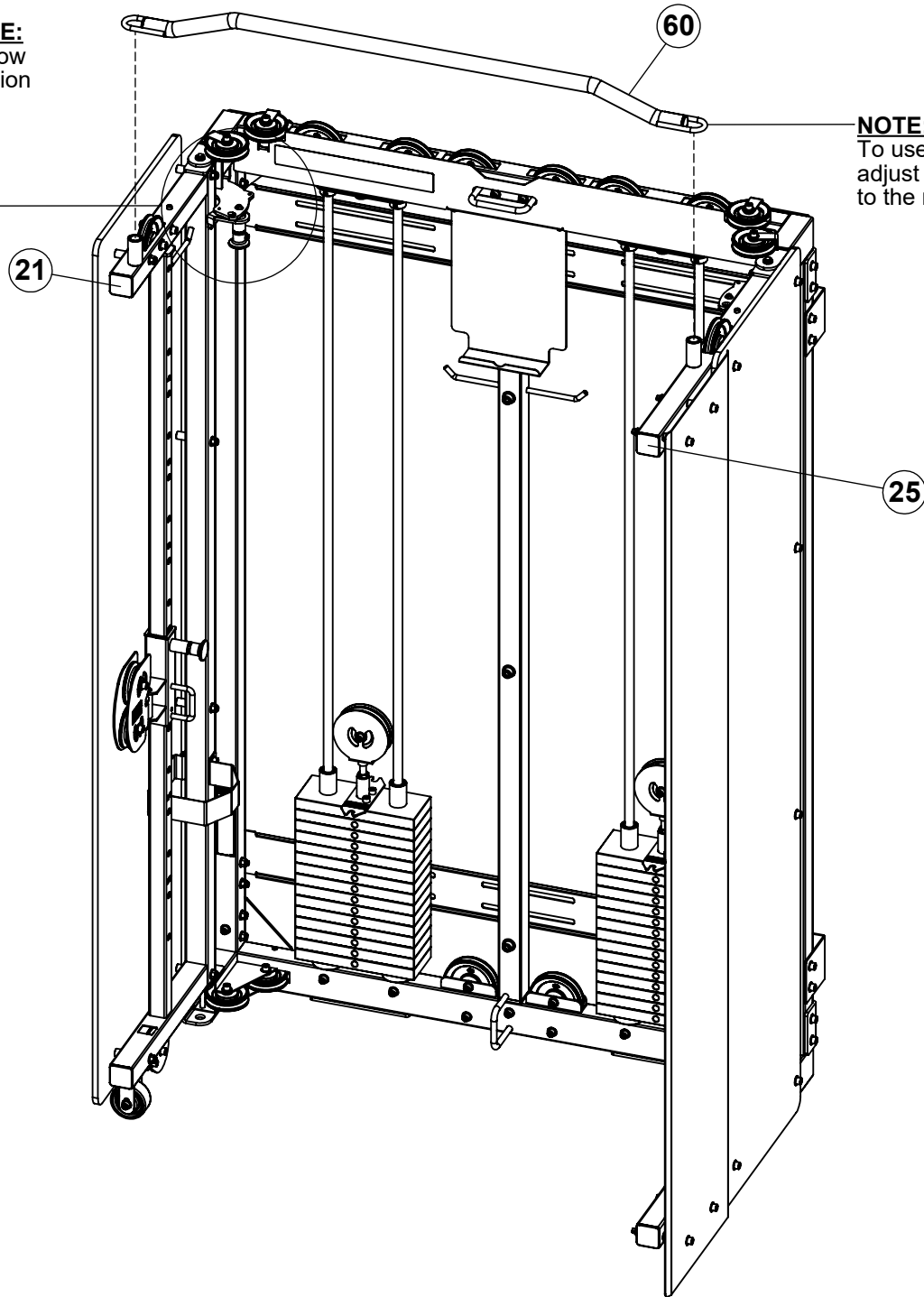

NOTE:
To use the PULL-UP/PRESS BAR,
adjust LEFT and RIGHT DOORS
to the narrow position

OPTIONAL KETTLBELL/DUMBBELL STORAGE: STEP 1

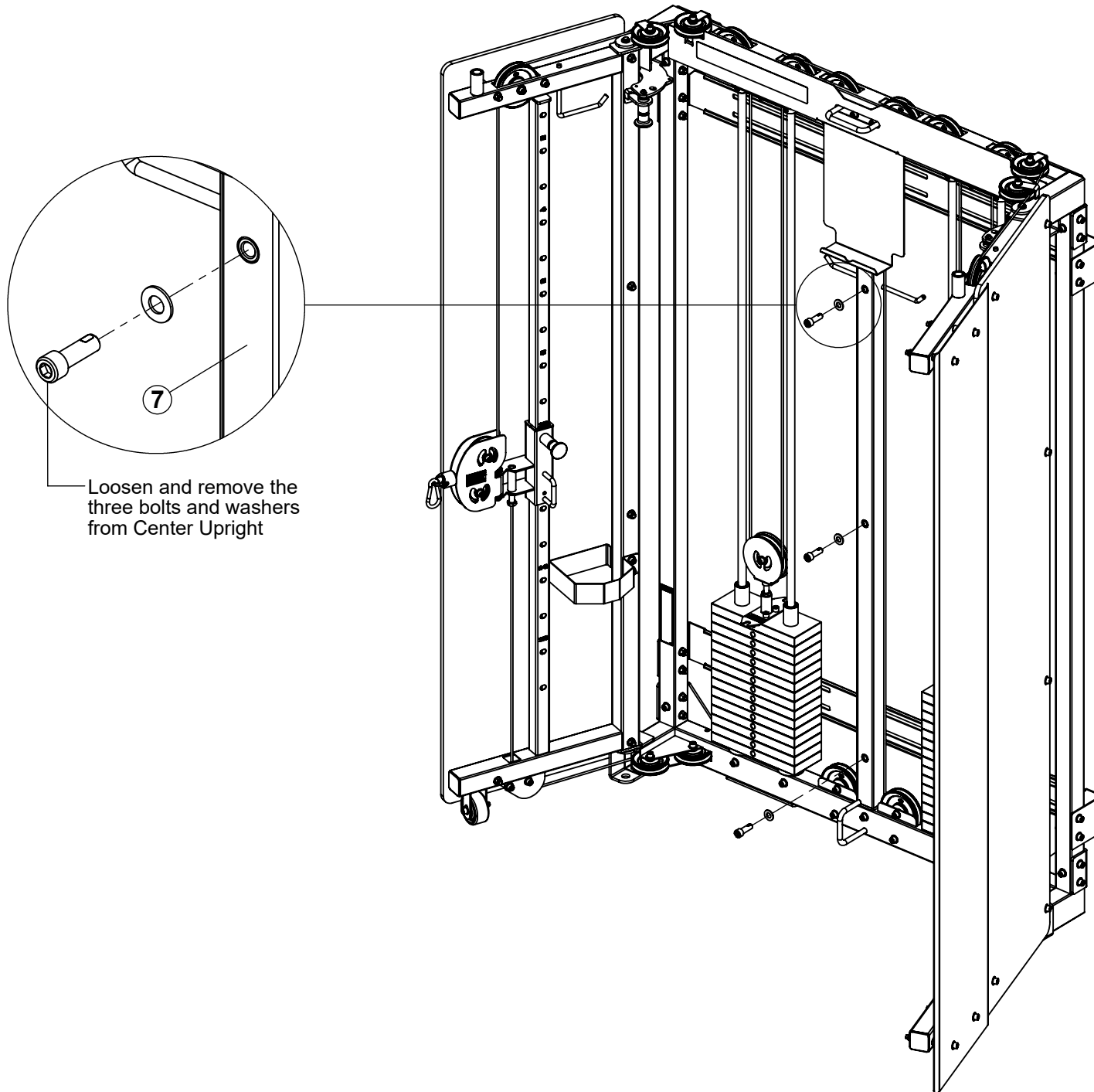

OPTIONAL KETTLBELL/DUMBBELL STORAGE: STEP 2

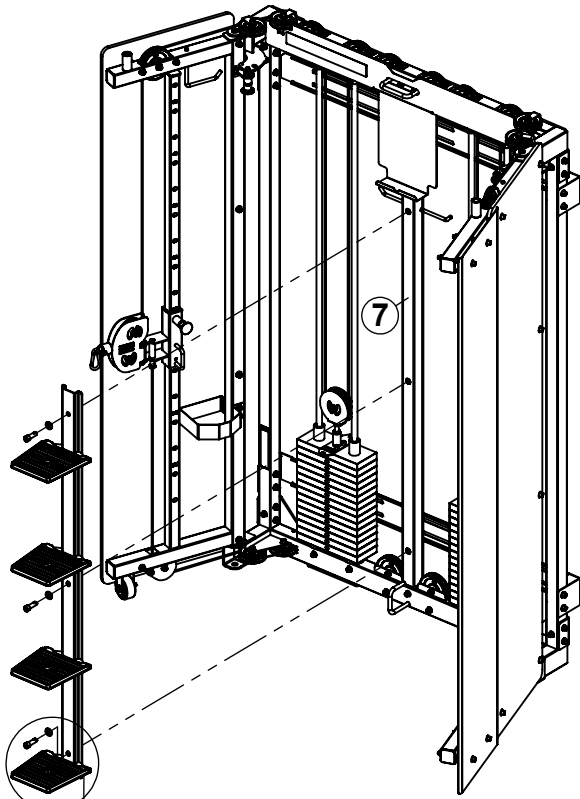

VKBS4
VERTICAL KETTLBELL
STORAGE 4 TRAYS

SECURELY assemble
KETTLBELL STORAGE
to CENTER UPRIGHT
using three bolts and
washers from previous step

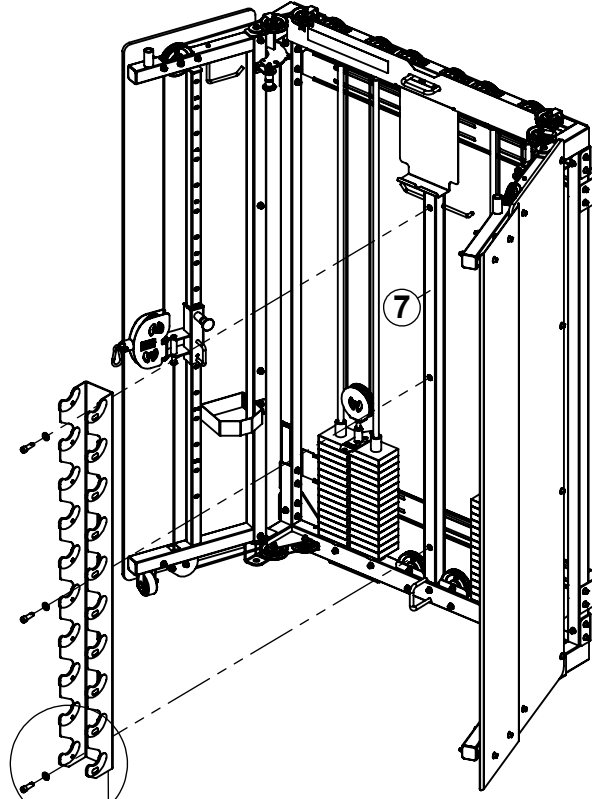

XCREATE-VDS5
VERTICAL DUMBBELL
STORAGE 5 PAIR

SECURELY assemble
DUMBBELL STORAGE
to CENTER UPRIGHT
using three bolts and
washers from previous step

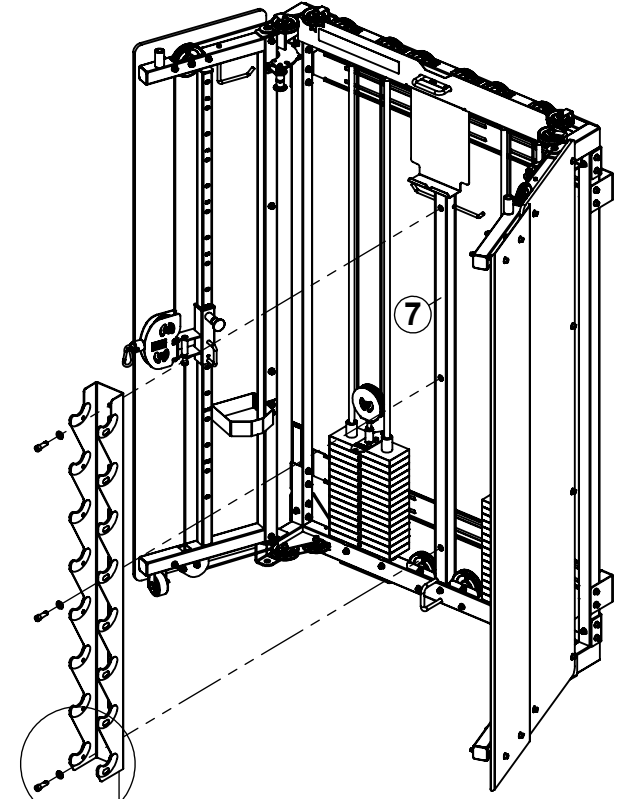

XCREATE-VDS4
VERTICAL DUMBBELL
STORAGE 4 PAIR

SECURELY assemble
DUMBBELL STORAGE
to CENTER UPRIGHT
using three bolts and
washers from previous step

STEP 39

MAINTENANCE:

GUIDE RODS: Clean and lubricate with a silicone or teflon base lubricant.

NUTS/BOLTS: Tighten and/or adjust as needed.

CABLES: Check tension, end fittings, and coating. Replace if damaged or worn. Check jam nuts on cable ends. **(NOTICE: NEW CABLES ALWAYS STRETCH DURING USE. REFER TO STEPS 24b & 27b FOR ADJUSTING CABLE TENSION)**

SPRING PINS: Check that spring pins fully engage the hole when released. Tighten spring pin nuts as needed.

FRAME: Wipe down and damp cloth.

GRIPS: Inspect and replace if they appear worn or damaged.

For customer service contact Torque Fitness Customer service at: 763-754-7533 (8:30 am - 5:00 pm CST). or 1-877-TORQUE5 (1-866-664-9894). www.service@torquefitness.com

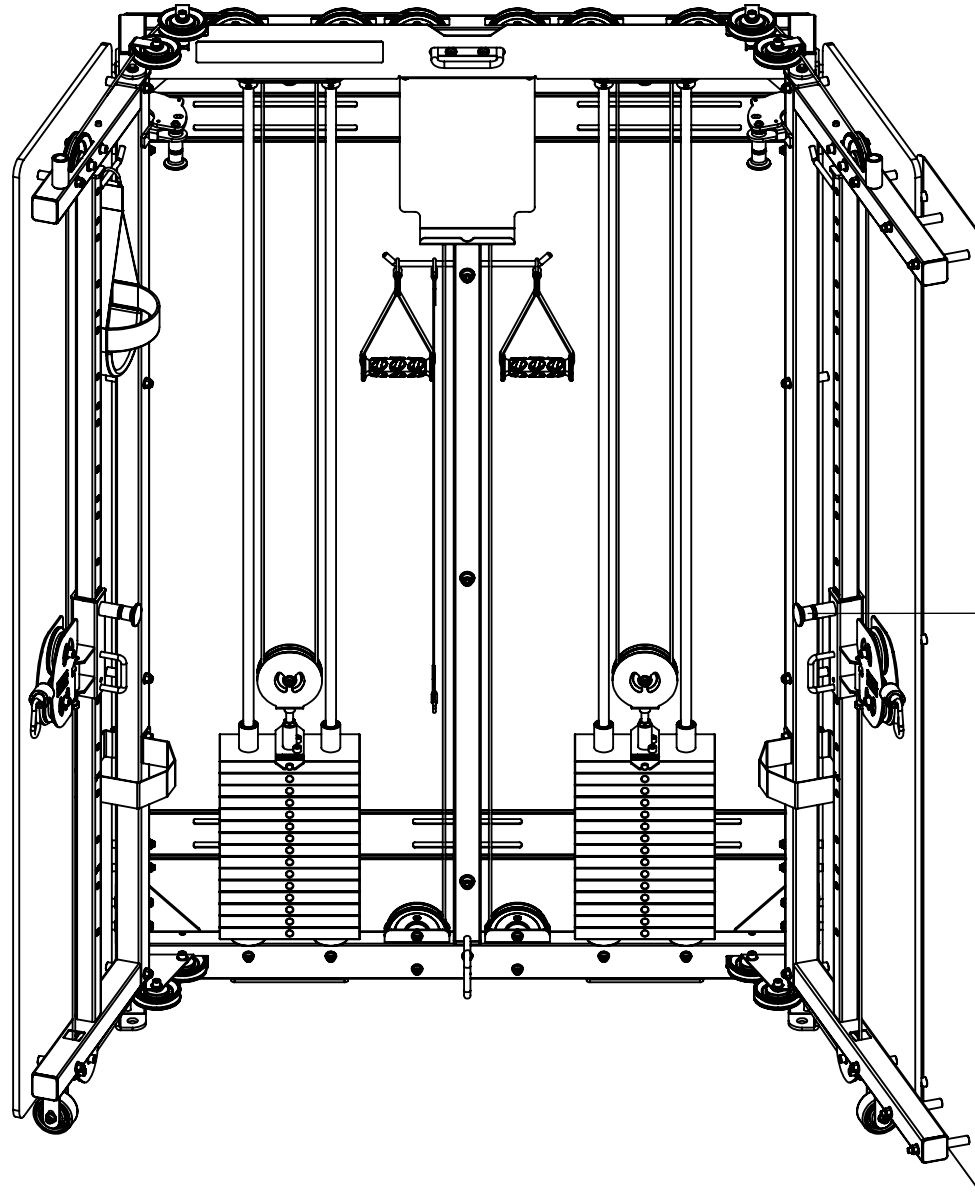

NOTE:

To adjust carriage up or down. Pull spring pin out with one hand and with the other hand adjust carriage to desired location. Release spring pin into the nearest hole.

F9W FOLD-AWAY STRENGTH TRAINER - RESISTANCE RATIO CHART

F9W-001-150LB

NUMBER	ACTUAL WEIGHT (LB)	ACTUAL WEIGHT (KG)	SINGLE HANDLE (LB)	BOTH HANDLES (LB)	SINGLE HANDLE (KG)	BOTH HANDLES (KG)
1	15	6.8	7.5	15.0	3.4	6.8
2	25	11.3	12.5	25.0	5.7	11.3
3	35	15.9	17.5	35.0	7.9	15.9
4	45	20.4	22.5	45.0	10.2	20.4
5	55	24.9	27.5	55.0	12.5	24.9
6	65	29.5	32.5	65.0	14.7	29.5
7	75	34.0	37.5	75.0	17.0	34.0
8	85	38.6	42.5	85.0	19.3	38.6
9	95	43.1	47.5	95.0	21.5	43.1
10	105	47.6	52.5	105.0	23.8	47.6
11	115	52.2	57.5	115.0	26.1	52.2
12	125	56.7	62.5	125.0	28.3	56.7
13	135	61.2	67.5	135.0	30.6	61.2
14	145	65.8	72.5	145.0	32.9	65.8
15	155	70.3	77.5	155.0	35.2	70.3

F9W-001-200LB

NUMBER	ACTUAL WEIGHT (LB)	ACTUAL WEIGHT (KG)	SINGLE HANDLE (LB)	BOTH HANDLES (LB)	SINGLE HANDLE (KG)	BOTH HANDLES (KG)
1	15	6.8	7.5	15.0	3.4	6.8
2	25	11.3	12.5	25.0	5.7	11.3
3	35	15.9	17.5	35.0	7.9	15.9
4	45	20.4	22.5	45.0	10.2	20.4
5	55	24.9	27.5	55.0	12.5	24.9
6	70	31.8	35.0	70.0	15.9	31.8
7	85	38.6	42.5	85.0	19.3	38.6
8	100	45.4	50.0	100.0	22.7	45.4
9	115	52.2	57.5	115.0	26.1	52.2
10	130	59.0	65.0	130.0	29.5	59.0
11	145	65.8	72.5	145.0	32.9	65.8
12	160	72.6	80.0	160.0	36.3	72.6
13	175	79.4	87.5	175.0	39.7	79.4
14	190	86.2	95.0	190.0	43.1	86.2
15	205	93.0	102.5	205.0	46.5	93.0

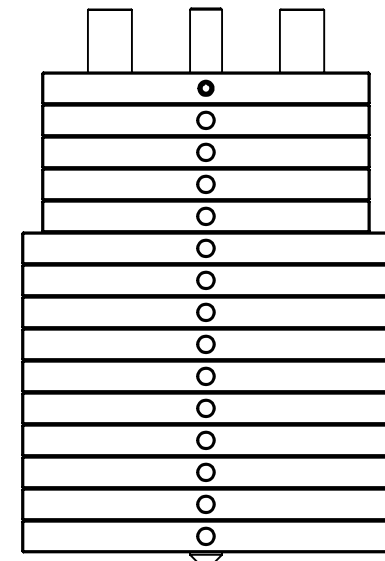
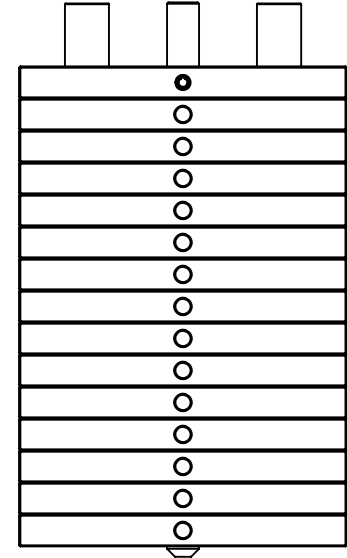

F9W FOLD-AWAY STRENGTH TRAINER - RESISTANCE RATIO CHART

F9W-001-225LB

NUMBER	ACTUAL WEIGHT (LB)	ACTUAL WEIGHT (KG)	SINGLE HANDLE (LB)	BOTH HANDLES (LB)	SINGLE HANDLE (KG)	BOTH HANDLES (KG)
1	15	6.8	7.5	15.0	3.4	6.8
2	30	13.6	12.5	25.0	6.8	13.6
3	45	20.4	17.5	35.0	10.2	20.4
4	60	27.2	22.5	45.0	13.6	27.2
5	75	34.0	27.5	55.0	17.0	34.0
6	90	40.8	32.5	65.0	20.4	40.8
7	105	47.6	37.5	75.0	23.8	47.6
8	120	54.4	42.5	85.0	27.2	54.4
9	135	61.2	47.5	95.0	30.6	61.2
10	150	68.0	52.5	105.0	34.0	68.0
11	165	74.8	57.5	115.0	37.4	74.8
12	180	81.6	62.5	125.0	40.8	81.6
13	195	88.5	67.5	135.0	44.2	88.5
14	210	95.3	72.5	145.0	47.6	95.3
15	225	102.1	77.5	155.0	51.0	102.1

