

X-GYM LOW SQUAT RACK ASSEMBLY GUIDE

VERSION: XGYM-LSR

PART #: 5725901-B

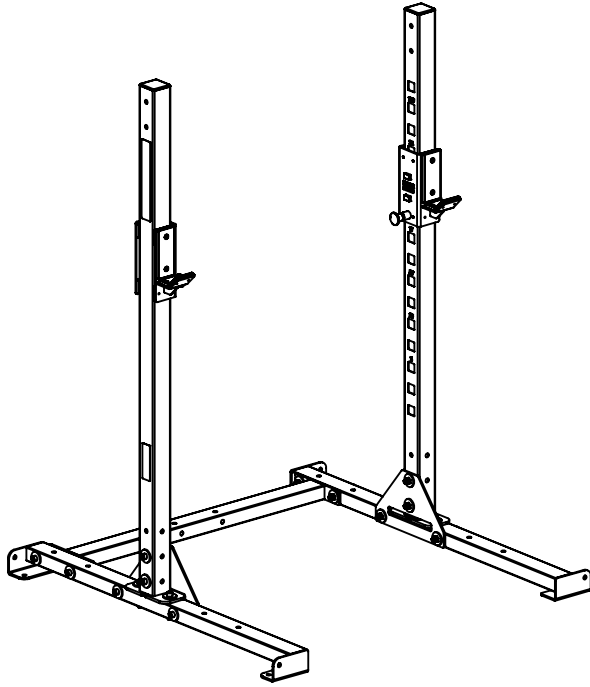

XGYM-LSR-1.0

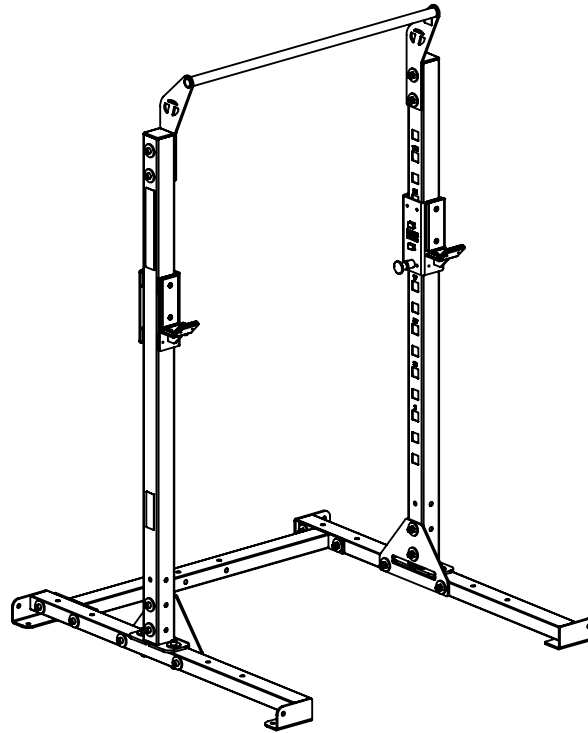

XGYM-LSR-3.0

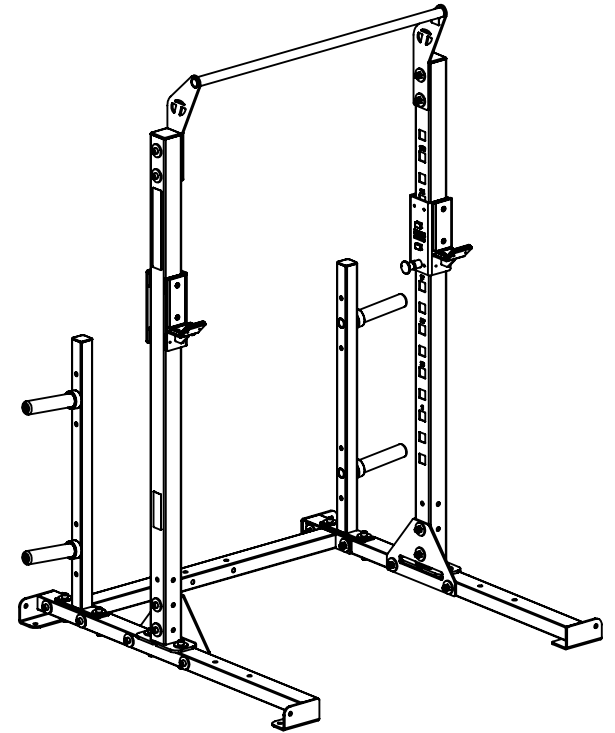

XGYM-LSR-5.0

TORQUE USA

ITEM	PART NUMBER	DESCRIPTION	QTY.
1	5712201	WLDMT, CROSS SUPPORT	1
2	5712501	WLDMT, LEFT BASE	1
3	5713001	WLDMT, RIGHT BASE	1
4	2005816	BOLT, 1/2-13 X 4-1/4" (108mm) SOCKET HEAD	16
5	2007801	WASHER, 1/2 X 1-3/4 X 4.5t	48
6	2001401	NUT, 1/2-13 LK ST ZN	28
7	57229PA	PTD ASSY, 6' UPRIGHT	2
8	2005812	BOLT, 1/2-13 X 3-1/4" (83mm) SOCKET HEAD	12
9	5712801	PLATE, UPRIGHT GUSSET	2
10	54737PA	PTD ASSY, LEFT BAR SUPPORT	1
11	54742PA	PTD ASSY, RIGHT BAR SUPPORT	1
12	5469501	WLDMT, WARRIOR SQUAT STAND CROSS (OPTIONAL)	1
13	57246PA	PTD ASSY, VERTICAL WEIGHT STORAGE SSB */**	2
14	54745PA	PTD ASSY, LEFT BAR CATCH **	1
15	54748PA	PTD ASSY, RIGHT BAR CATCH	1
16	55478PA	PTD ASSY, XDSA LEFT	1
17	55481PA	PTD ASSY, XDSA RIGHT	1
18	5621301	ASSY, GROUND ROTATIONAL TRAINER	1
19	2001301	WASHER, FLAT 1/2 SAE ST ZN	9
20	55782PA	PTD ASSY, BATTLE ROPE ANCHOR	1
21	57412PA	DOUBLE PLAY - BAR STORAGE/BATTLE ROPE ANCHOR	1

TABLE OF CONTENTS:

- Warnings: Page 3
- General Notes: Page 4
- Squat Stand Assembly: Page 5 - 9
- Optional Attachments: Pages 10 - 16
- Maintenance: Page 17

NOTES:

Assembly steps 1 - 5 show steps to assemble the 1.0 base system. Additional assembly steps for the 3.0, 5.0 and other optional attachments, are shown in subsequent steps and are listed "optional"

* Standard option for 3.0 system

** Standard option for 5.0 system

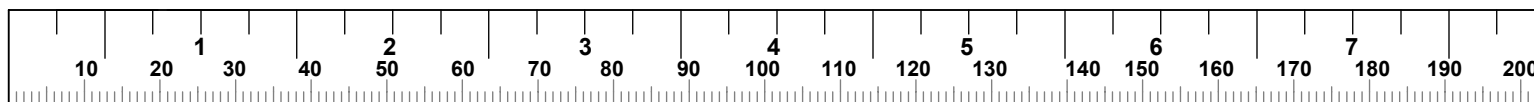

WARNING !

Important safety instructions for using Equipment

There is a risk assumed by the individuals who use this type of equipment. To minimize risk, you must follow these precautions:

- **READ ALL INSTRUCTIONS AND WARNING LABELS COMPLETELY PRIOR TO ANY USE OR ASSEMBLY.** Failure to read and follow the safety instructions and warnings within the Assembly and Maintenance Guide may result in possible serious injury or death. Use this product only for the intended uses described in the Assembly and Maintenance Guide and exercise booklet. **DO NOT** modify equipment in anyway. **Any use other than as intended or modification of product will void any and all product warranties.**
- Consult your physician before starting any exercise program. Warm up properly before engaging in resistance training. Stop exercising and consult a physician immediately if you experience dizziness, nausea, faintness, chest pain, shortness of breath or any other abnormal symptoms during use of this equipment.
- Certain exercise equipment and/or equipment may not be suitable or appropriate for pregnant women, people with heart conditions, balance impairment or other pre-existing health problems. Persons with disabilities should consult a physician and obtain medical approval prior to using this product and should only use this product under close supervision. **Failure to comply with these instructions will void any and all product warranties.**
- Carefully inspect equipment before each use. Replace all parts at the first sign of wear or damage. Tighten all loose connections. Do not disassemble, remove any parts or components or otherwise attempt to repair this product. **DO NOT** use product if product appears damaged. **DO NOT** attempt to fix a broken or jammed machine. **Failure to comply with these instructions will void any and all product warranties.**
- Keep body and clothing clear of all moving parts. Do not put anything foreign on or near this product when in use. Wear comfortable clothing which does not impair freedom of movement. Do not wear clothing which is too loose and could get caught in moving parts.
- Make sure all spring pin adjustments are fully engaged after making an adjustment and before using the product.
- Children and pets must not be allowed near this machine. Supervise teenagers. This product is not a toy.
- If unsure of proper use of this product, contact Torque Fitness Customer service at: 763-754-7533 (8:30 am - 5:00 pm CST), or 1-877-TORQUE5 (1-866-664-9894). www.service@torquefitness.com

Important Safety Instructions for Assembling Equipment

- **Assistance is required. Torque Fitness recommends using more than one person to assemble this equipment.**
- This product must be assembled on a flat, level surface to assure its proper function. Locate the unit away from walls or furniture to allow easy access during assembly and use.
- Read each numbered step in Assembly and Maintenance Guide and follow the steps in sequence. Skipping ahead may result in damage to the equipment and may require components to be disassembled.
- Wear proper attire during the assembly process. Do not wear clothing which is too loose or open toed shoes.

Obtaining Service

- Do not attempt to service the product yourself except for maintenance tasks described in this manual.
- Refer to the Adjustments and Maintenance section at the back of this manual for product operation and service.
- For further information, visit our website at www.torquefitness.com or contact us at www.service@torquefitness.com
- If you call or email customer service, have the model number and serial number(s) available.

GENERAL NOTES

CAUTION: More than one person is required to assemble this unit. Do not attempt to assemble by yourself.

Unpacking the Equipment

- This product may be packaged and shipped in multiple boxes. Parts from all of the boxes are required for various steps during the assembly process.
- Carefully open each box and arrange all the parts near the area where assembly is to take place.
- **CAUTION:** Use extreme care when cutting plastic tie wraps and package banding. A wire cutter works best for protecting yourself and the parts.
- **CAUTION:** Some of the internal boxes may contain upholstery. Do not use a utility knife to open any boxes or the pads may be damaged.
- The hardware is packed in bags. Carefully open each bag and sort them per parts list on the next page.
- Before starting assembly, identify each part and hardware item as listed in the parts list on the next page. If any items are missing, contact Torque Fitness Customer service at: 763-754-7533 (8:30 am - 5:00 pm CST). or 1-877-TORQUE5 (1-866-664-9894). www.service@torquefitness.com
- **Note:** Some items listed in the parts list may already be pre-installed on the product.

Tools Required

- Rubber mallet or hammer
- 3/4" wrench
- Ratchet with 3/4" socket
- 3/8" Allen wrench
- Allen wrench set
- Wire snips (to cut plastic tie wraps)
- Scissors or utility knife (to cut hardware bags)
- Step stool or ladder
- Tape measure

Optional Equipment

- Optional equipment may be available for this product.
- Follow the instructions included with the optional equipment to assemble it to the base product.

Assembly Tips

- In a continual effort to improve our products, specifications are subject to change.
- A 6" scale is provided at the bottom of every page. To correctly measure the bolts, measure from underneath the bolt head to the end of the bolt as illustrated below.
- Read all notes on each page before beginning that step.
- Some of the items shown in the assembly steps may already be pre-assembled.

Assembly Tips Continued

- **Note:** Some items have been hidden for assembly clarity.
- **Note:** Some pre-assembled parts may need to be temporarily removed in order to complete the step. Follow the instructions or damage to the product could occur.
- Some parts may have extra holes that will not be used. Use only the holes depicted in the instructions.
- Certain parts make reference to the right and left side of the machine. For this product, left and right is determined by facing the product.
- Provide ample space around the product for ease of assembly.
- **DO NOT** fully tighten any connections until instructed to do so. This will help insure that the alignment of all of the parts will be correct.
- Insert all bolts in the direction indicated in the instructions. Failure to do so may result in clearance issues and will degrade the aesthetics of the product.
- Carefully follow instructions for all pivot points. In general, primary rotating parts have connections that should be securely tightened, while secondary connections need to be loosen 1/4 turn.

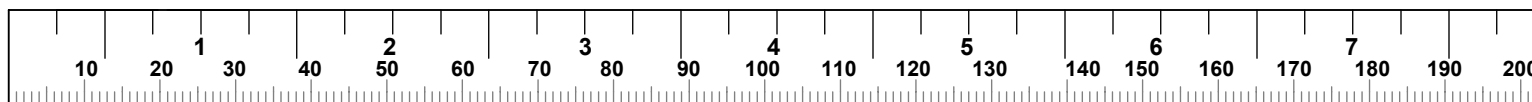

STEP 1

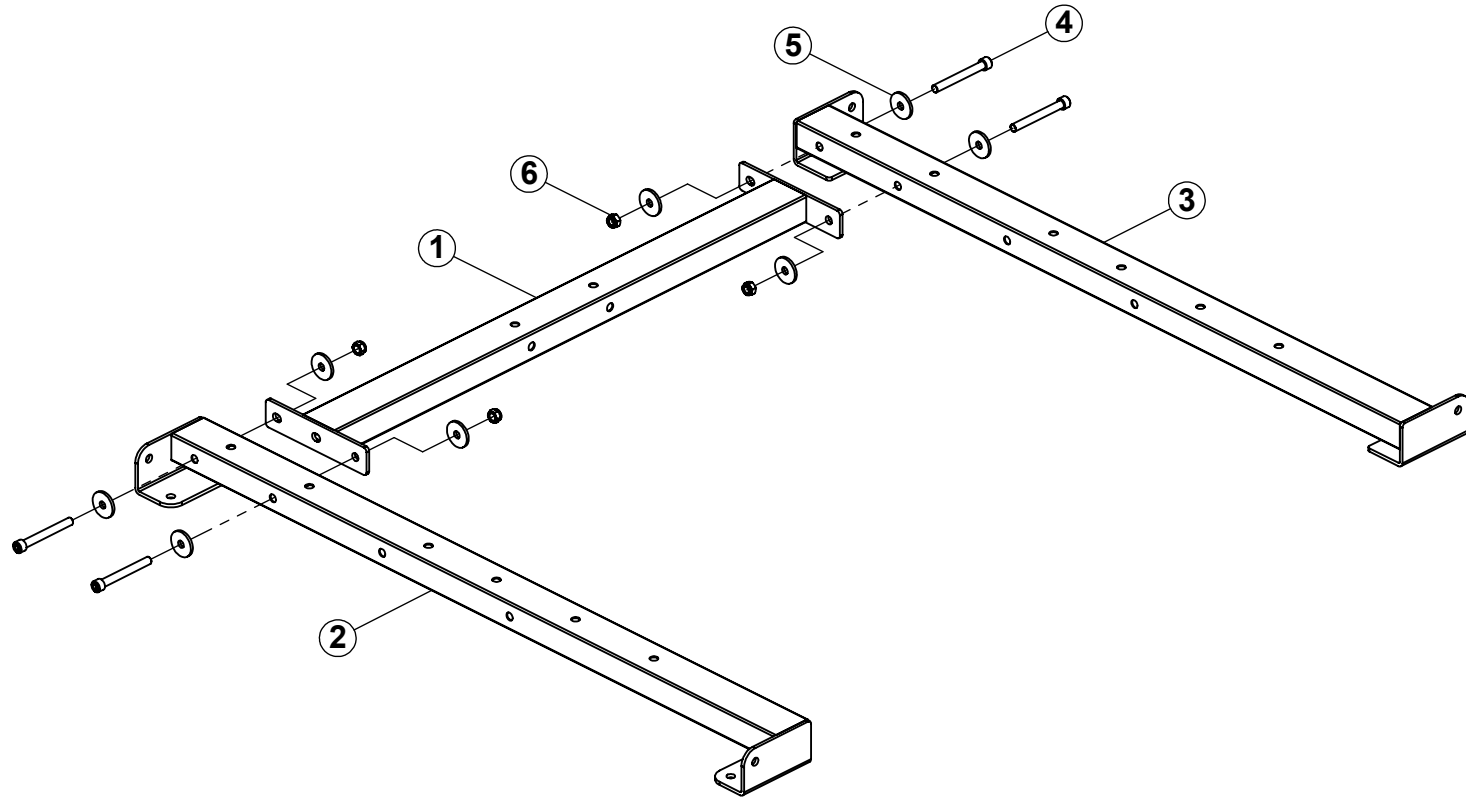

NOTE:

LOOSELY tighten bolt connections in this step.

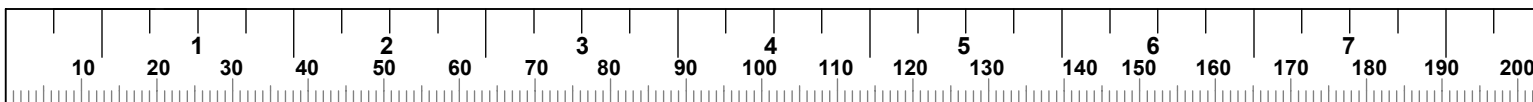

STEP 2

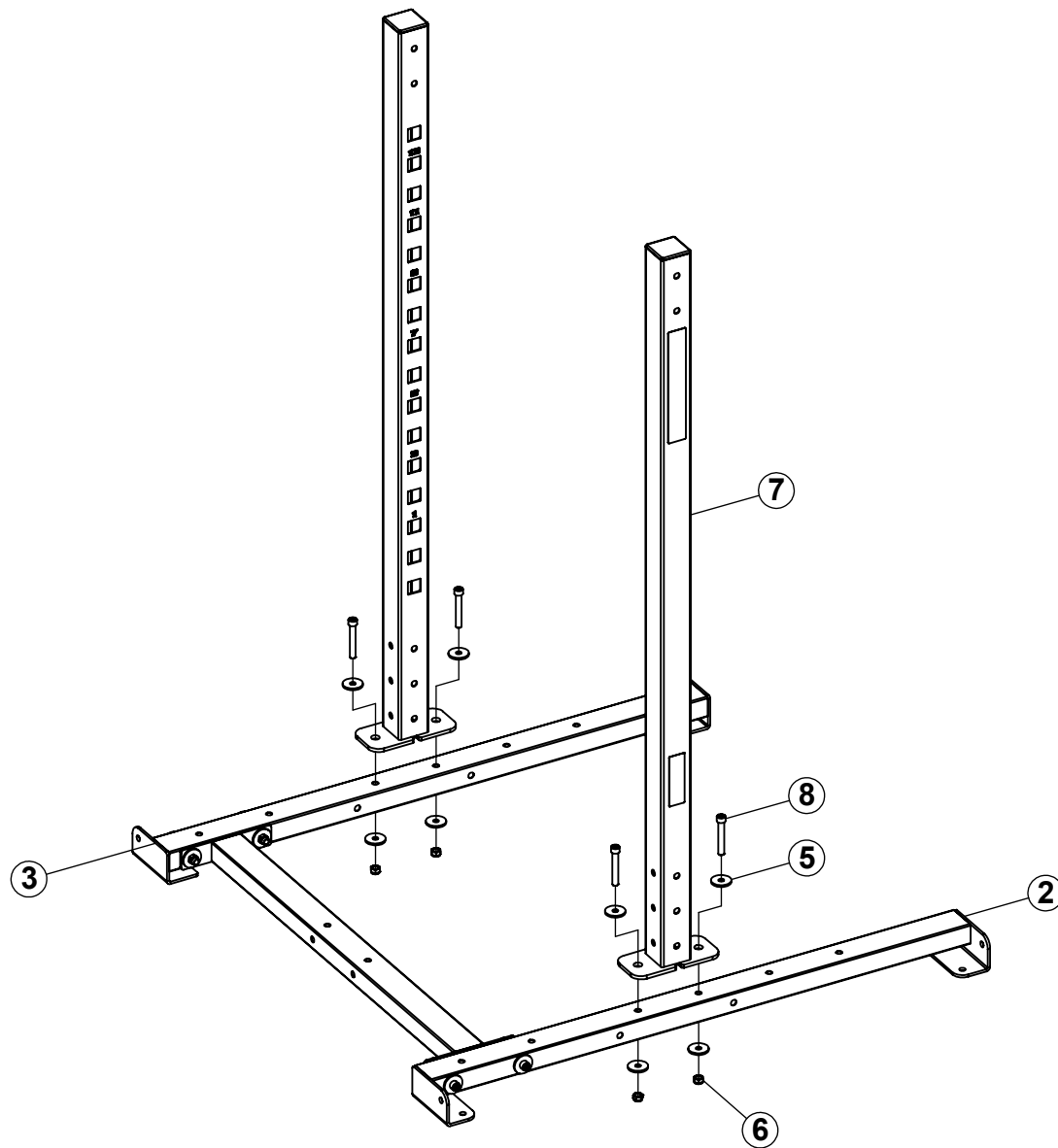

NOTE:

LOOSELY tighten bolt connections in this step.

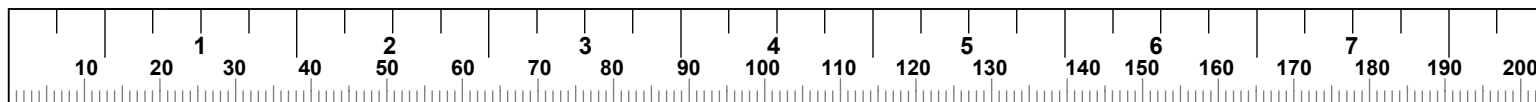

STEP 3

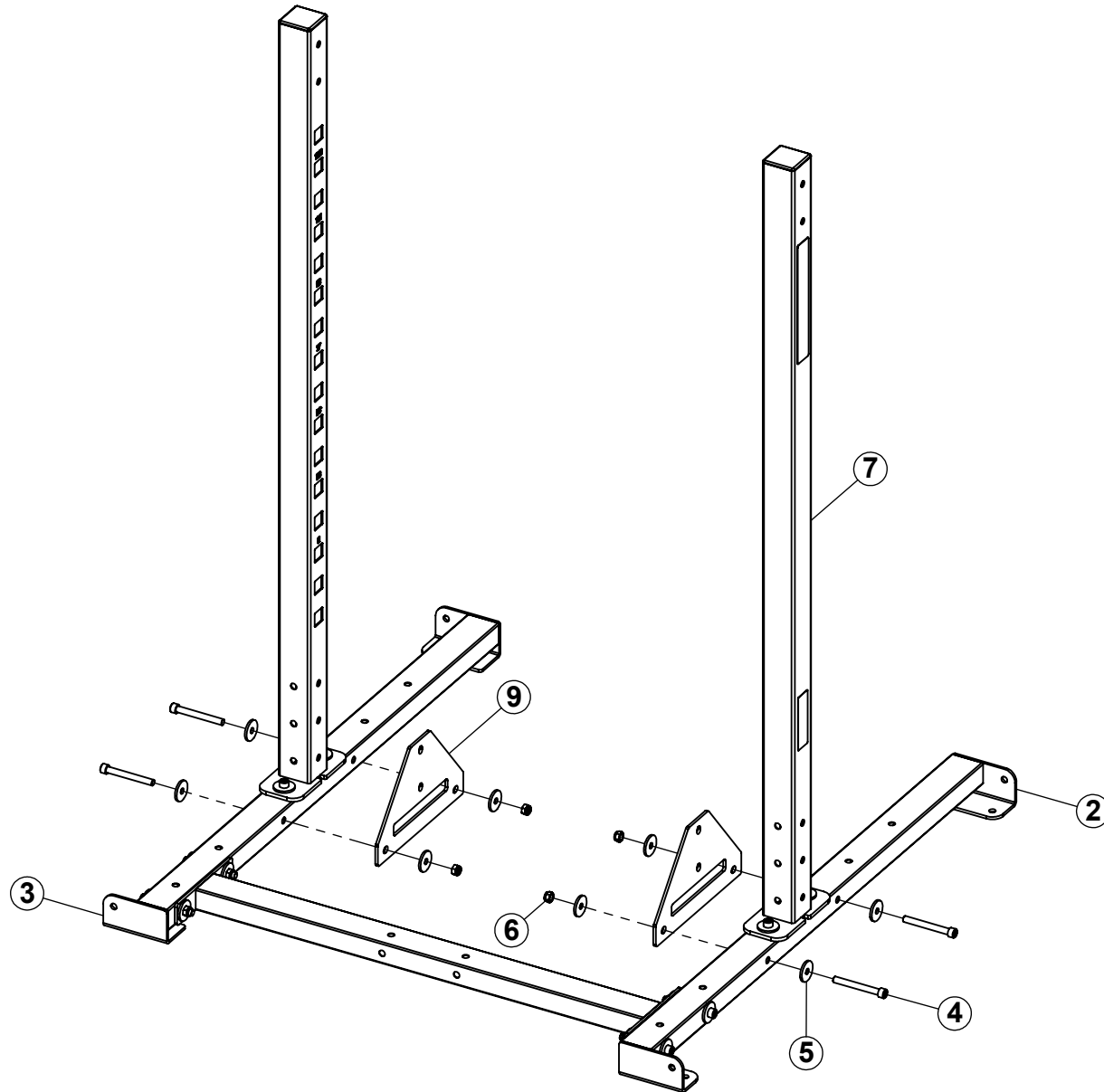

NOTE:

LOOSELY tighten bolt connections in this step.

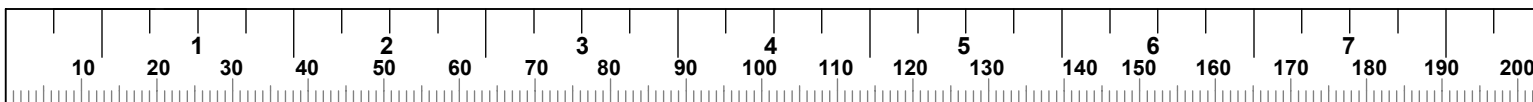

STEP 4

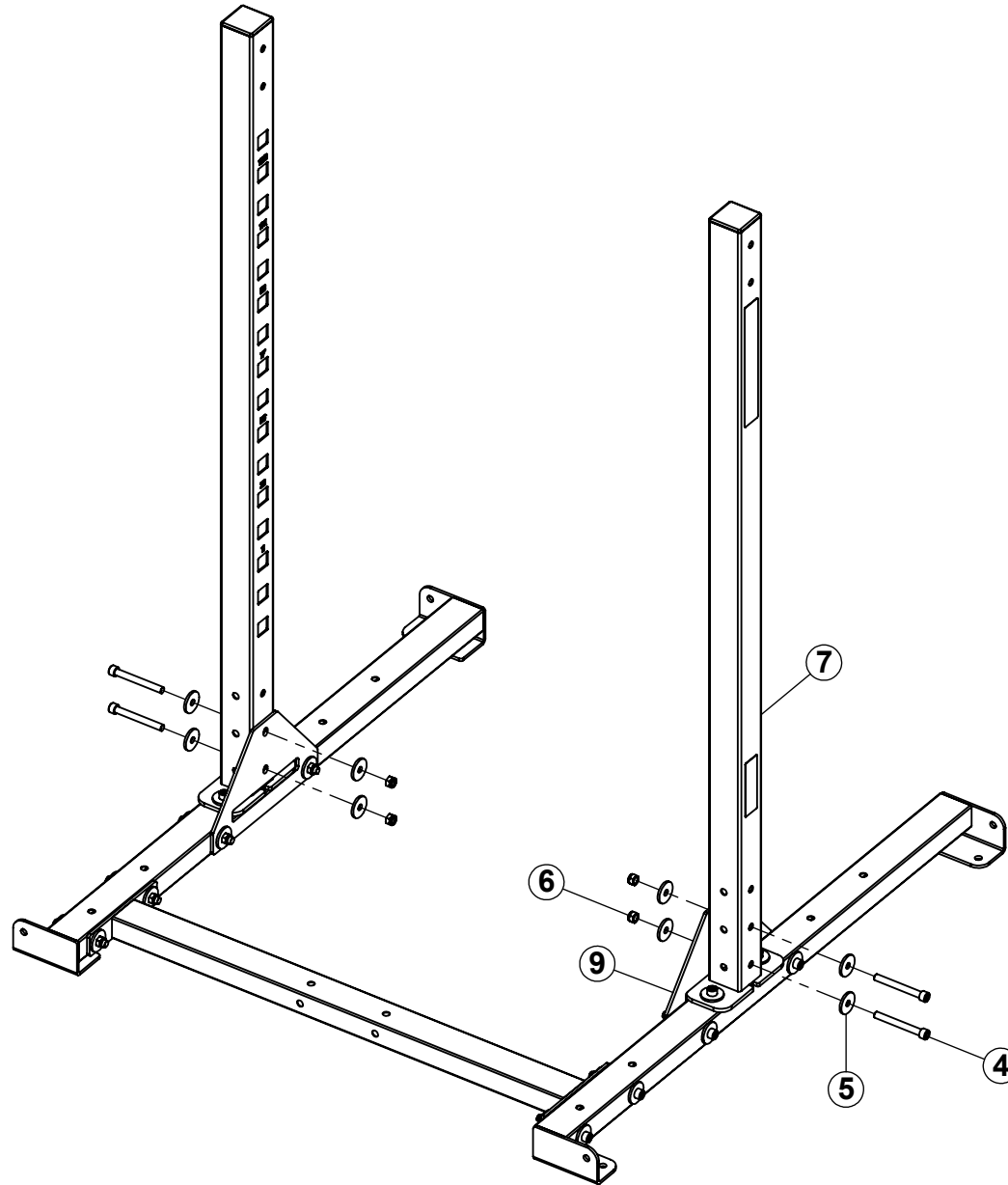

NOTE:

SECURELY tighten all bolts in this step and previous steps.

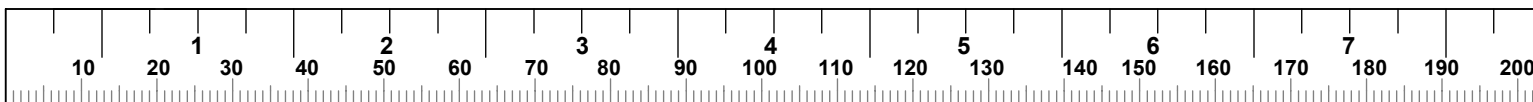

STEP 5

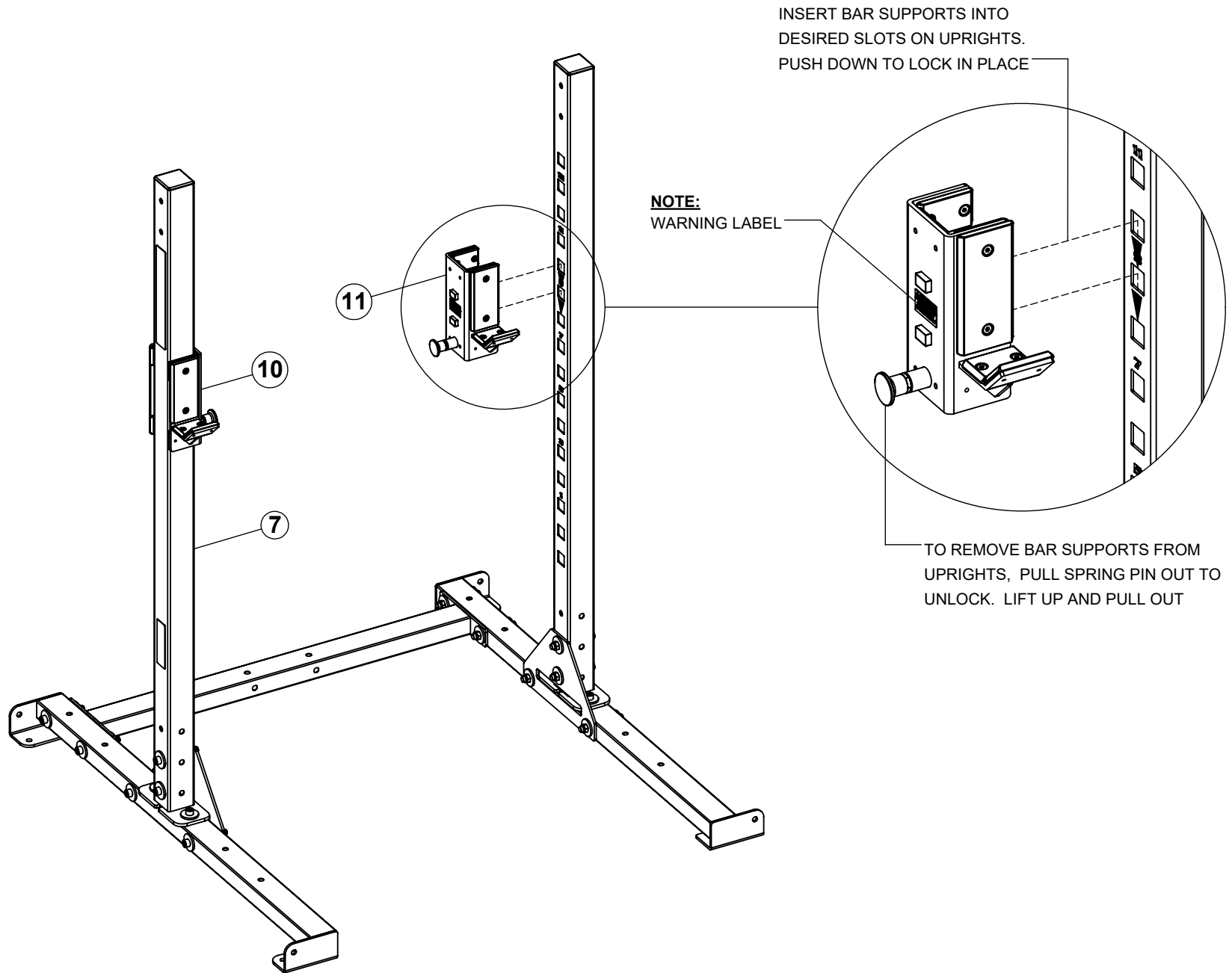

STEP 6 (OPTIONAL SQUAT STAND CROSS)

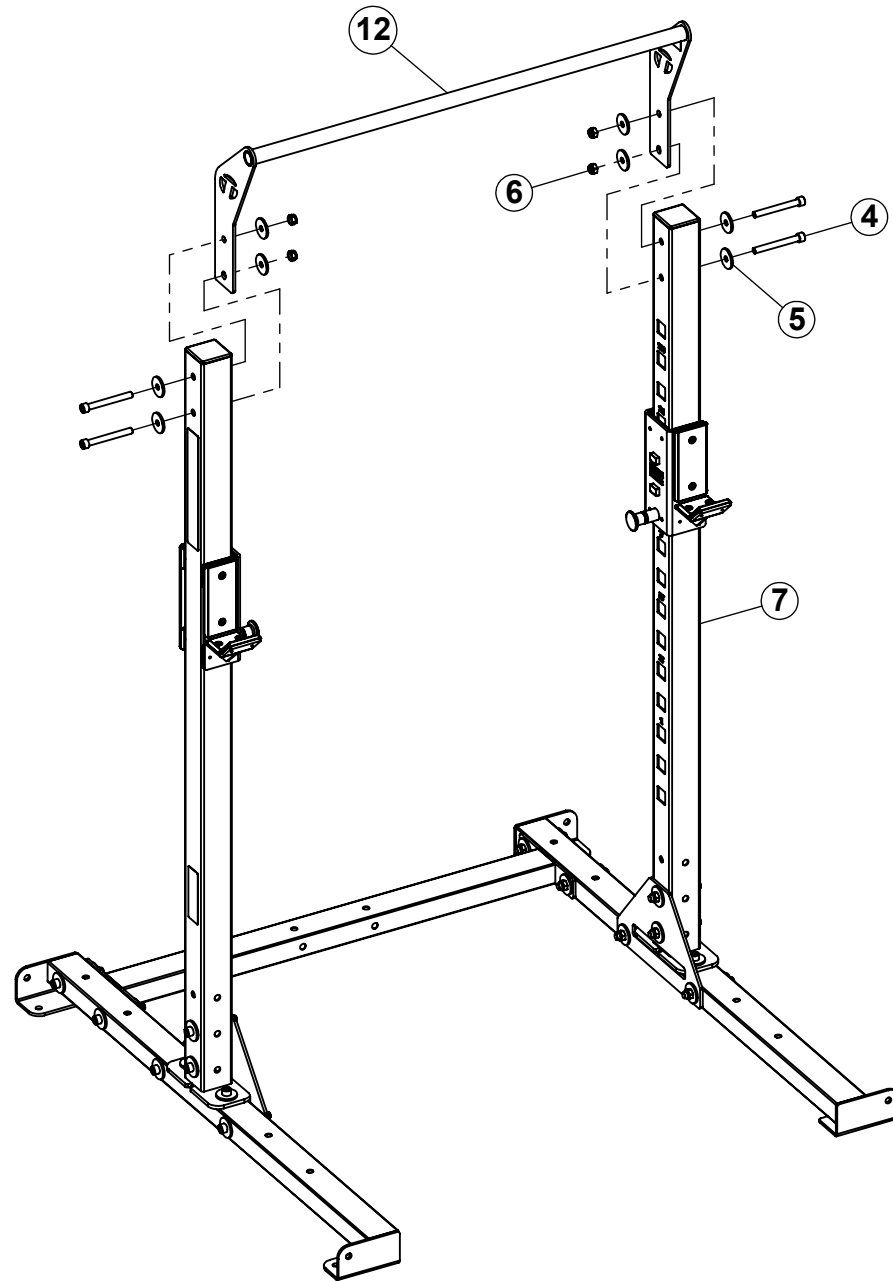

NOTE:

SECURELY tighten all bolt connections in this step.

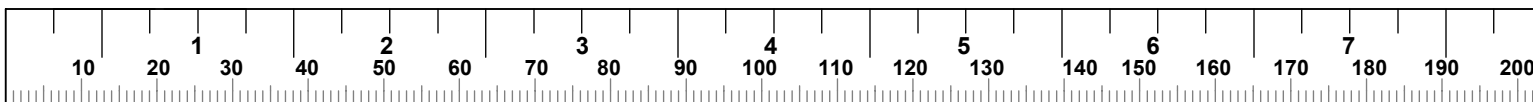

STEP 7 (OPTIONAL VERTICAL WEIGHT STORAGE)

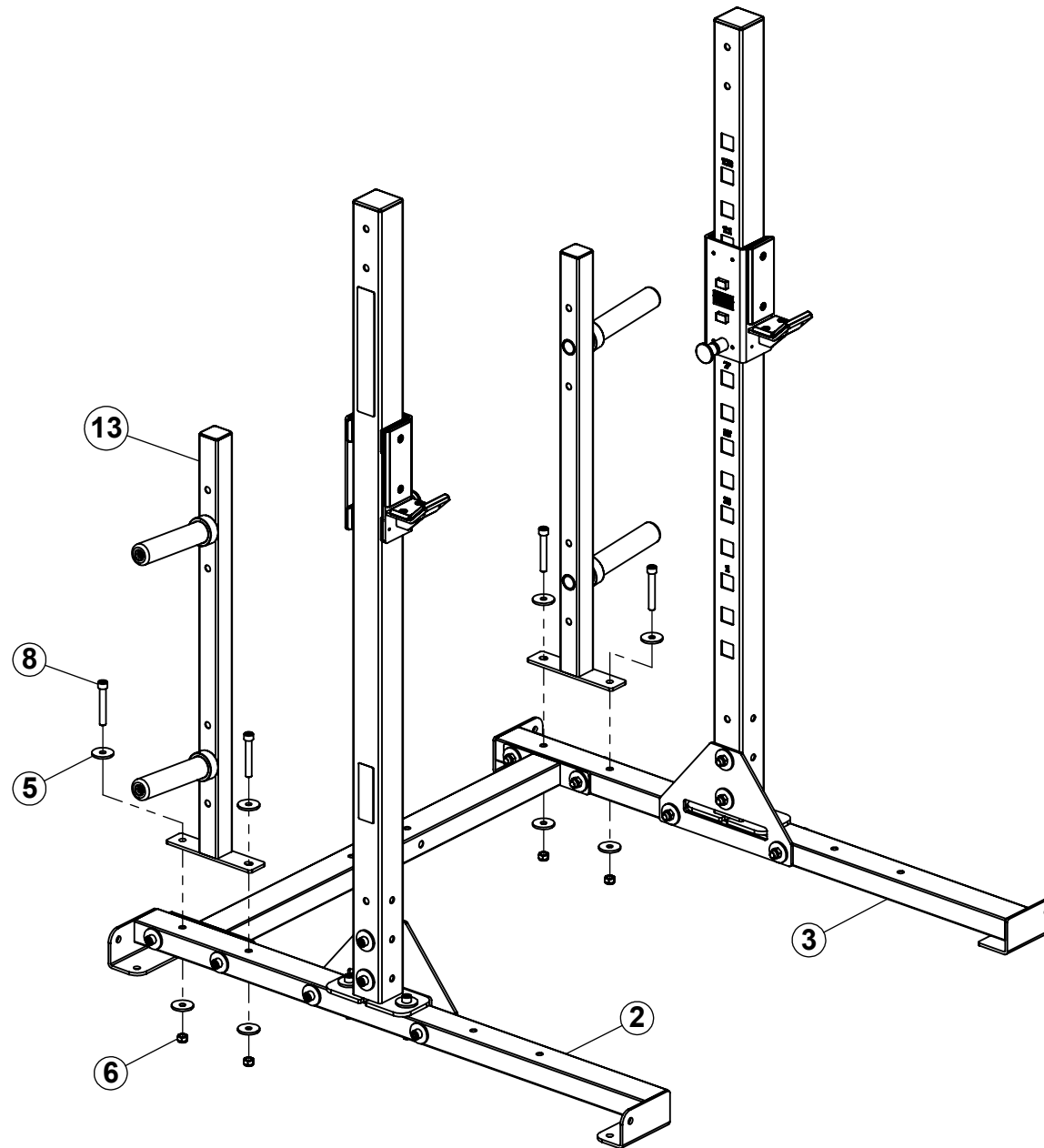

NOTE:

SECURELY tighten all bolt connections in this step.

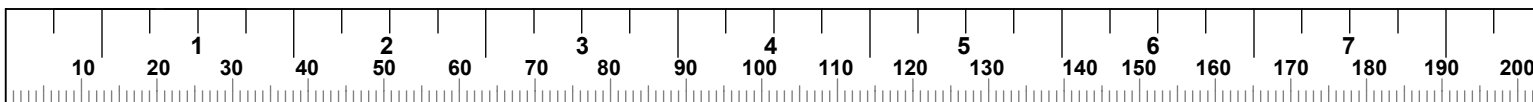

STEP 8 (OPTIONAL BAR CATCHES)

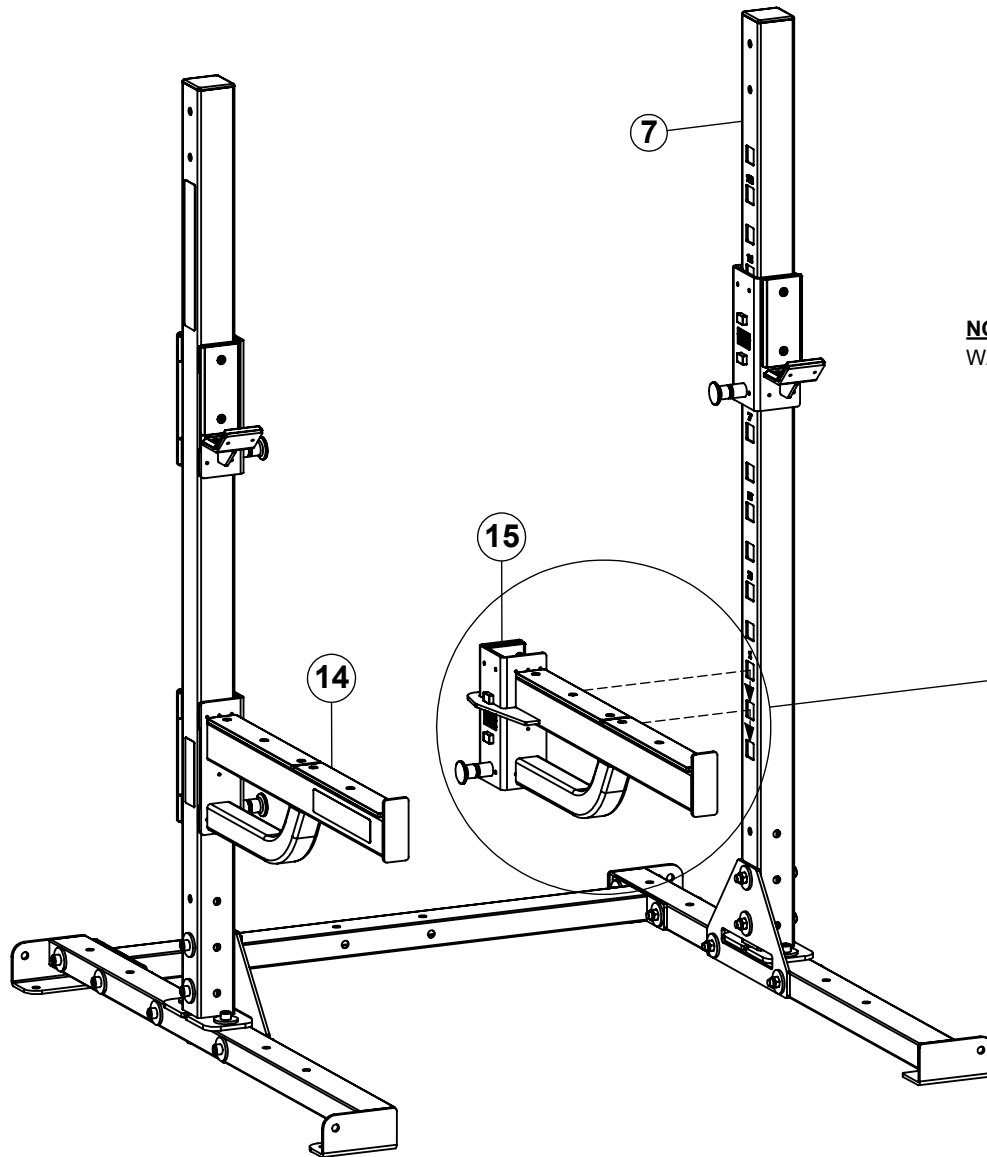

INSERT BAR SUPPORTS INTO
DESIRED SLOTS ON UPRIGHTS.
PUSH DOWN TO LOCK IN PLACE

NOTE:
WARNING LABEL

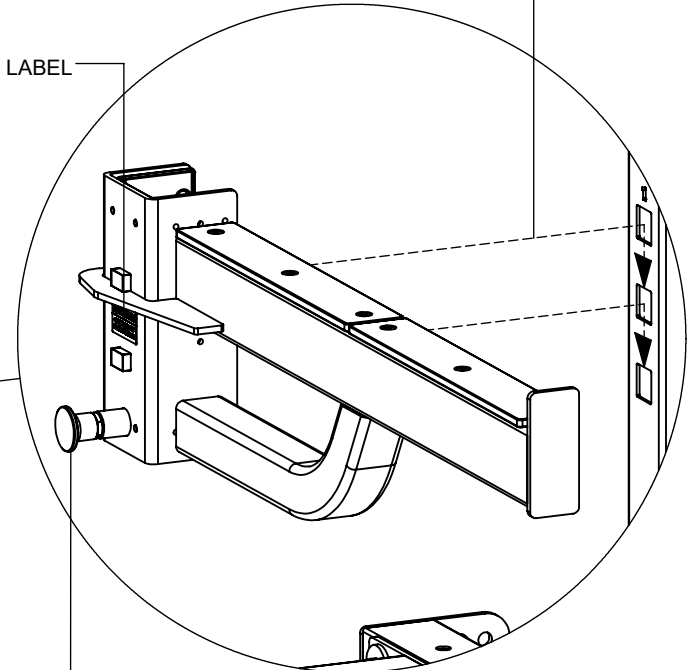

TO REMOVE BAR SUPPORTS FROM
UPRIGHTS, PULL SPRING PIN OUT TO
UNLOCK. LIFT UP AND PULL OUT

STEP 9 (OPTIONAL DIP ATTACHMENT)

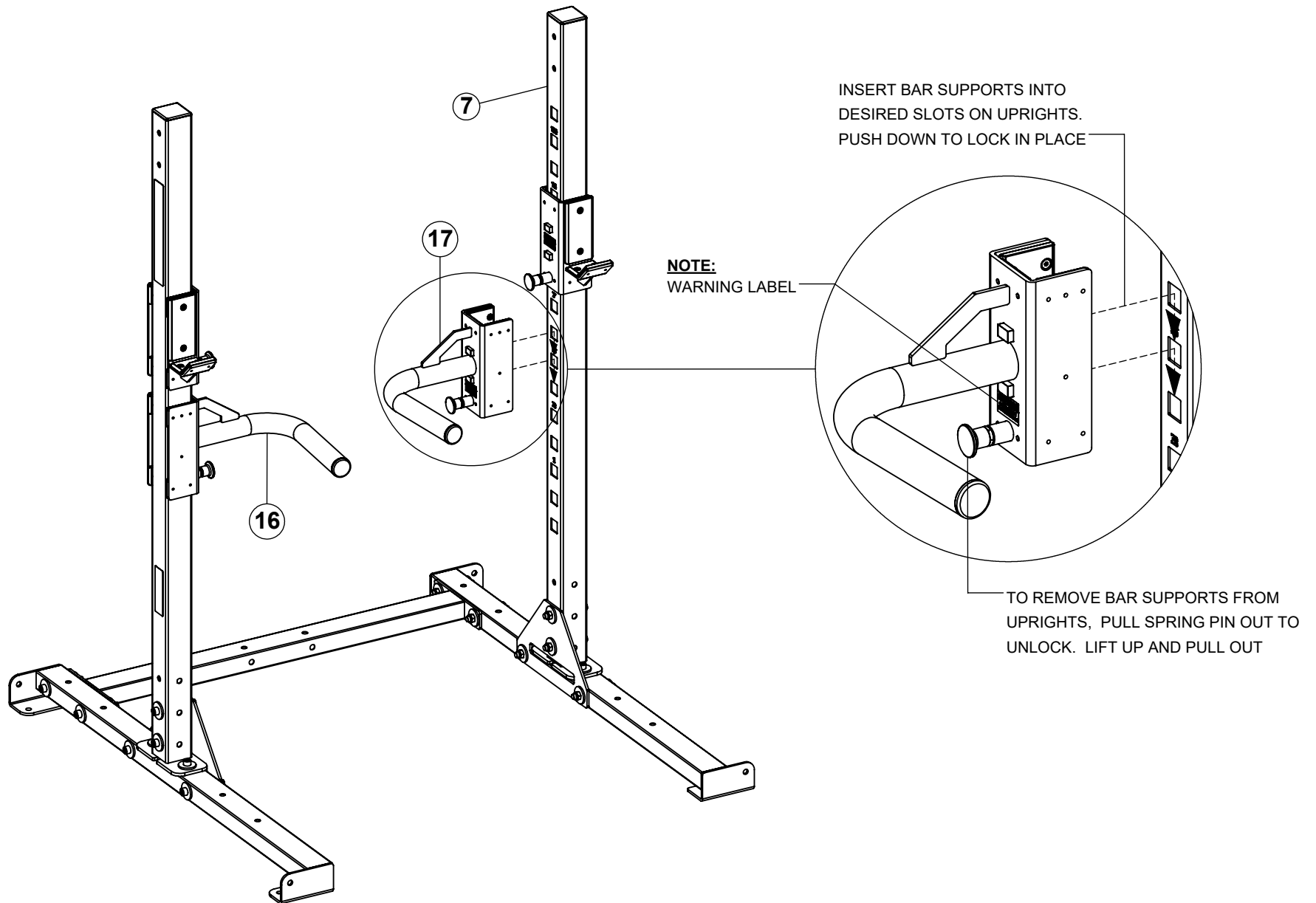

STEP 10 (OPTIONAL GROUND ROTATIONAL TRAINER)

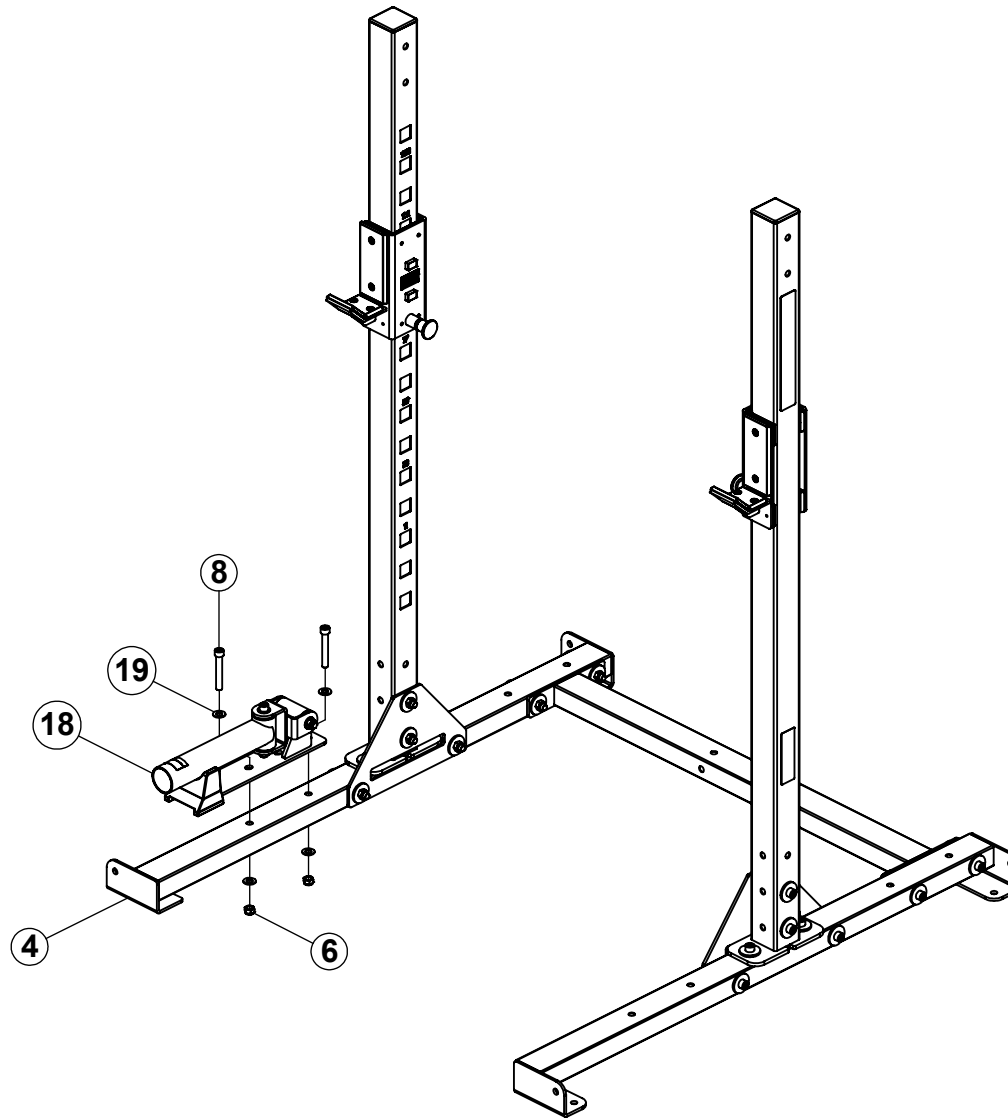

NOTE:

SECURELY tighten all bolt connections in this step.

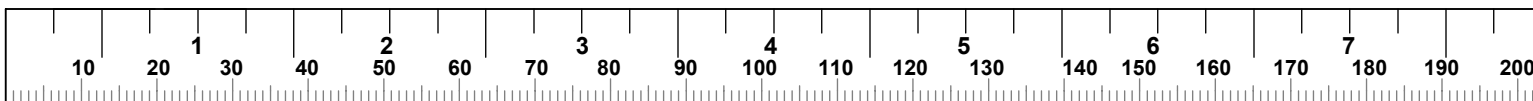

STEP 11 (OPTIONAL BATTLE ROPE ANCHOR)

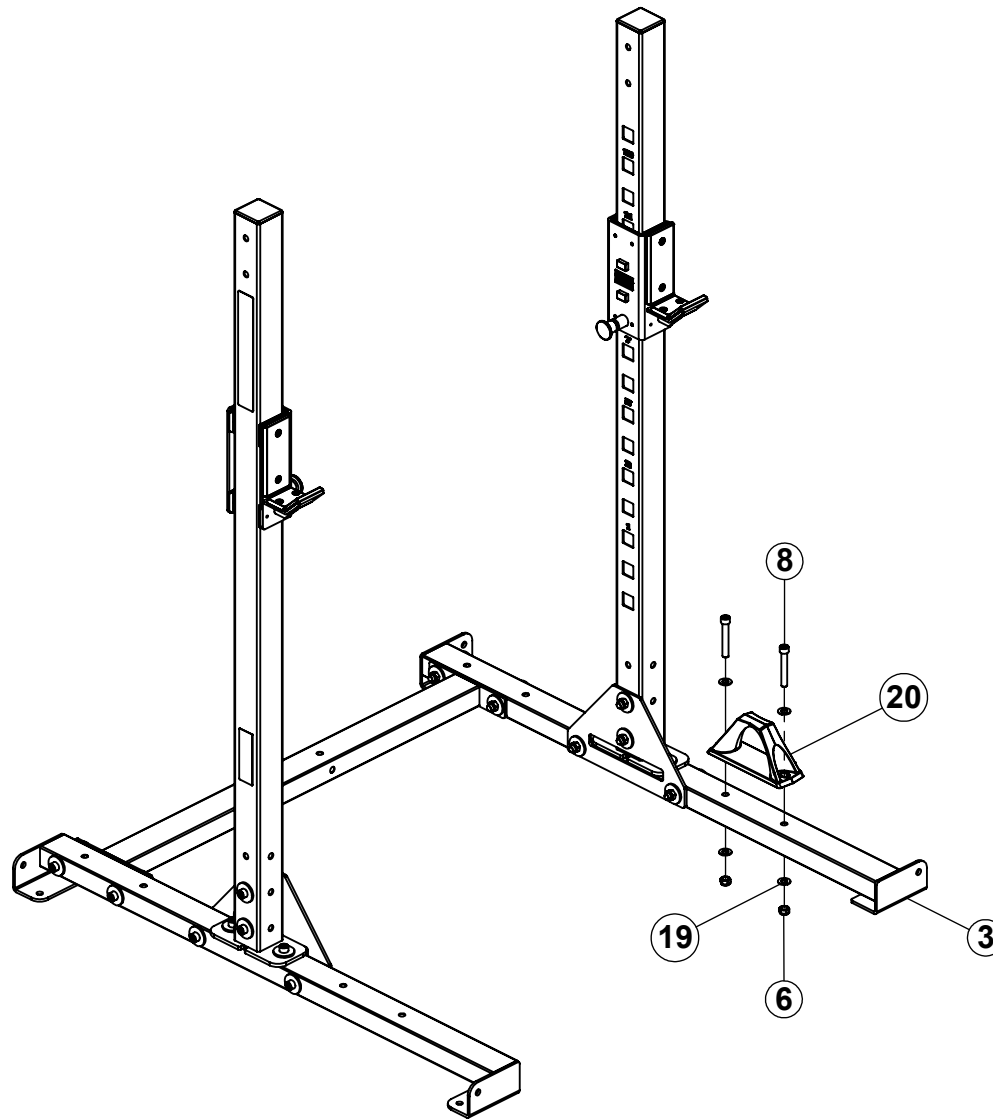

NOTE:

SECURELY tighten all bolt connections in this step.

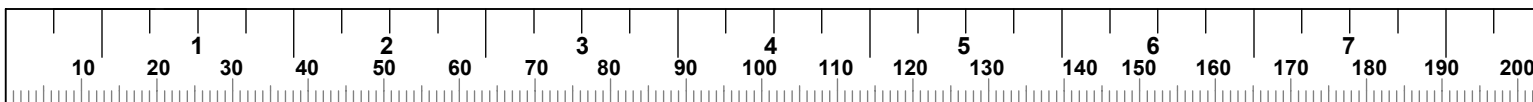

STEP 12A AND 12B (OPTIONAL DOUBLE PLAY)

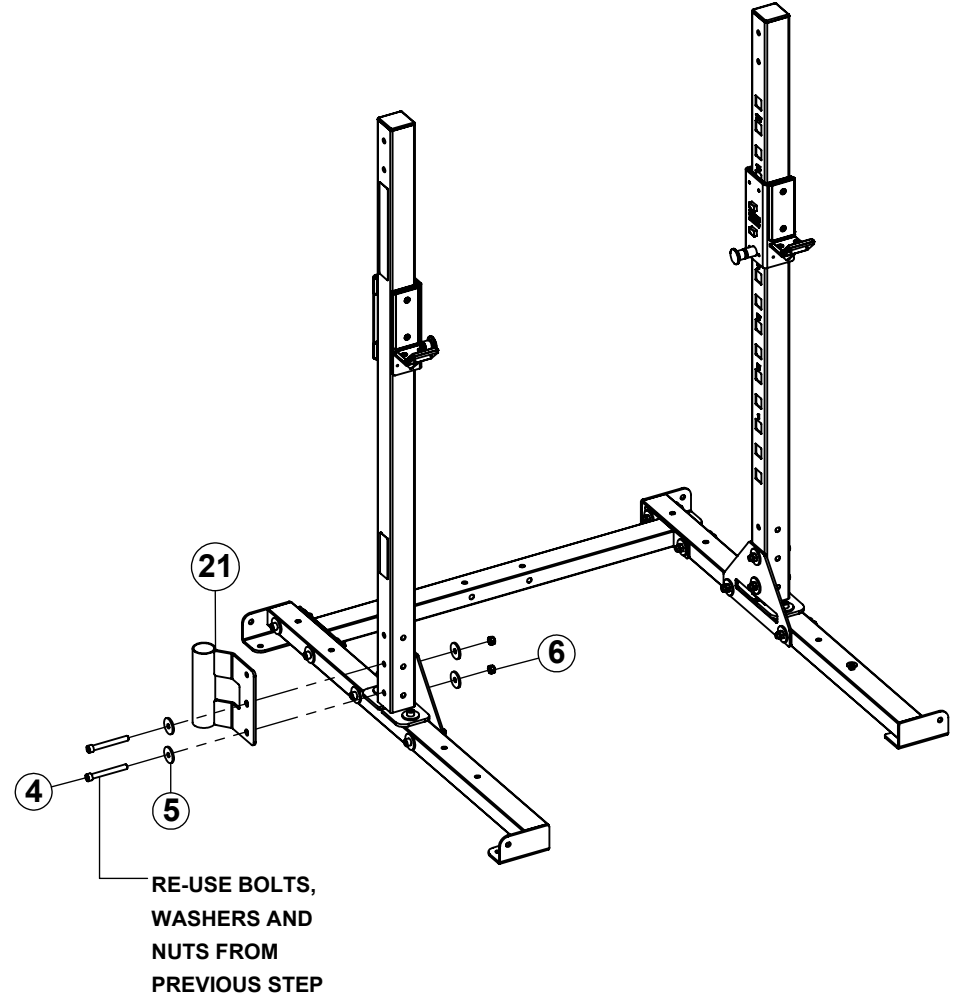
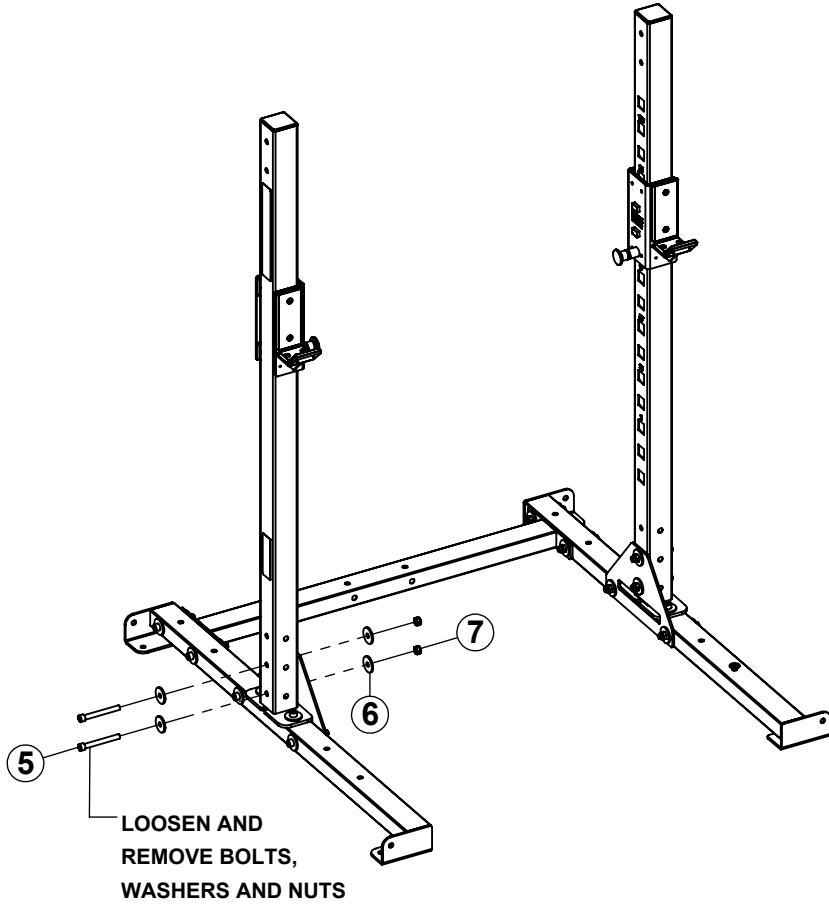

NOTE:

SECURELY tighten all bolt connections in this step.

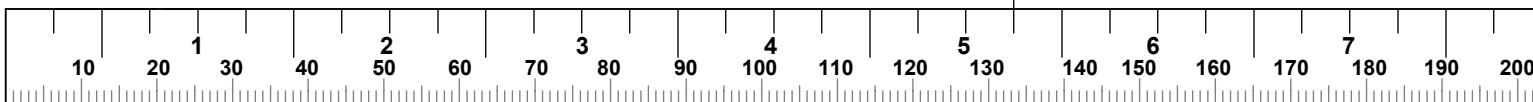

MAINTENANCE:

- **NUTS/BOLTS:** Inspect periodically, tighten and/or adjust as needed.
- **SPRING PINS:** Check that spring pins fully engage the hole when released. Tighten spring pin nuts as needed.
- **FRAME:** Wipe down frame with a damp cloth.

Torque Fitness
11201 Xeon Street NW Ste 101
Coon Rapids, MN USA 55448

www.torquefitness.com
Toll free: 1-877-TORQUE5 (1-866-664-9894)
or 763-754-7533 (8:30 am – 5:00 CST).

For sales: sales@torquefitness.com
For service: service@torquefitness.com

 <https://twitter.com/TorqueFitnessHQ>

 <https://www.instagram.com/torquefitnessusa/>

 <https://www.youtube.com/c/TorqueFitness/>

 <https://www.facebook.com/torquefitness/>

