



Lat Pulldown bar and two short strap handles with overmolded grips included.



Compatible with X-Gym High Squat Racks and Power Racks.

Nylon sleeves protect paint finish on solid weight peg shafts.

Molded urethane foot plate guards

Model number	XG-CAHL-101-F07
Width x Height X Depth (each)	40.0 in X 89.0in X 29.0 in (100 cm x 226 cm x 74 cm)
Weight	59.3 lb (26.9 kg)
Frame Color	Black Satin and Chrome
Residential Warranty	10 year frame and welds/1 year parts/90 days misc.

TOP VIEW

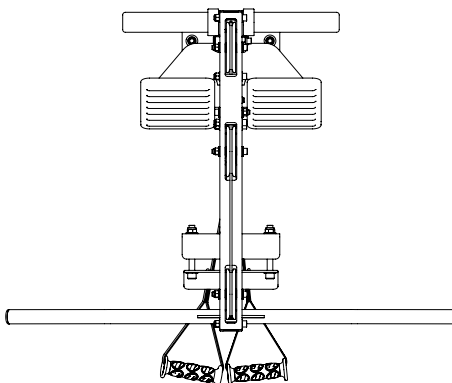

NOTES

- XG-CAHL Boom must bolt to a rectangular cross. (not compatible with Single, Double, Triple, Multi-grip, or Ninja, Crosses.
- An optional Multi-grip pull-up attachment is available (XG-PUAMG) that mounts to the rectangular cross.
- Weight peg length = 7.3 inches (186 mm) each side. (Use to determine weight capacity based on thickness of weight plates being used.)