

X-GYM WALL RACK - 3.0 & 5.0 ASSEMBLY GUIDE

VERSION: XGYM-WR-3.0 & XGYM-WR-5.0

PART #: 5734601-C

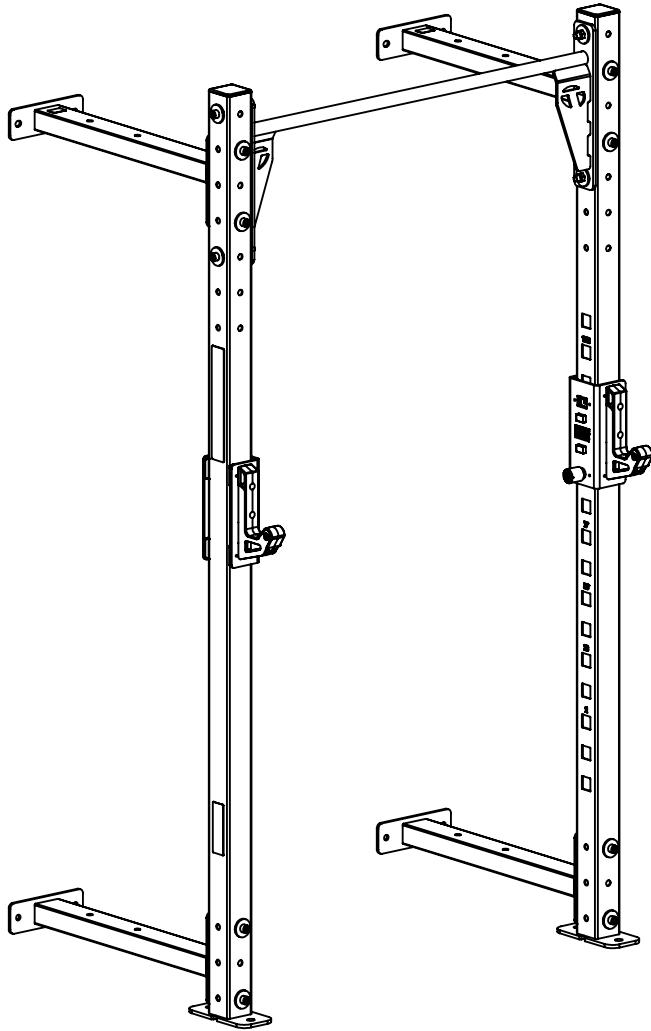

XGYM-WR-3.0

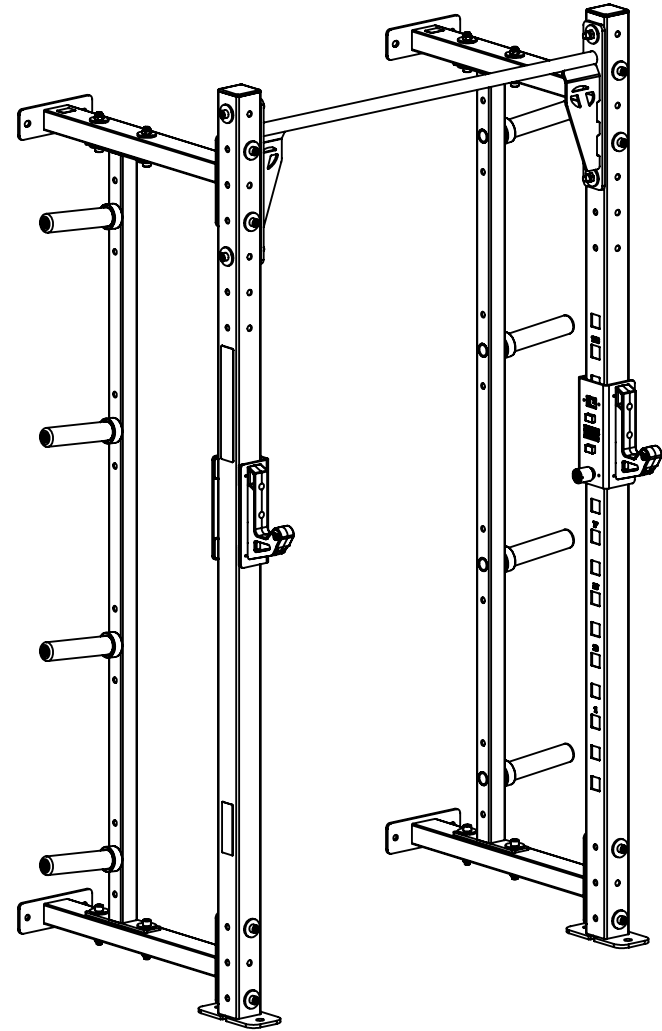

XGYM-WR-5.0

WARNING !

Important safety instructions for using Equipment

There is a risk assumed by the individuals who use this type of equipment. To minimize risk, you must follow these precautions:

- **READ ALL INSTRUCTIONS AND WARNING LABELS COMPLETELY PRIOR TO ANY USE OR ASSEMBLY.** Failure to read and follow the safety instructions and warnings within the Assembly and Maintenance Guide may result in possible serious injury or death. Use this product only for the intended uses described in the Assembly and Maintenance Guide and exercise booklet. **DO NOT** modify equipment in anyway. **Any use other than as intended or modification of product will void any and all product warranties.**
- Consult your physician before starting any exercise program. Warm up properly before engaging in resistance training. Stop exercising and consult a physician immediately if you experience dizziness, nausea, faintness, chest pain, shortness of breath or any other abnormal symptoms during use of this equipment.
- Certain exercise equipment and/or equipment may not be suitable or appropriate for pregnant women, people with heart conditions, balance impairment or other pre-existing health problems. Persons with disabilities should consult a physician and obtain medical approval prior to using this product and should only use this product under close supervision. **Failure to comply with these instructions will void any and all product warranties.**
- Carefully inspect equipment before each use. Replace all parts at the first sign of wear or damage. Tighten all loose connections. Do not disassemble, remove any parts or components or otherwise attempt to repair this product. **DO NOT** use product if product appears damaged. **DO NOT** attempt to fix a broken or jammed machine. **Failure to comply with these instructions will void any and all product warranties.**
- Keep body and clothing clear of all moving parts. Do not put anything foreign on or near this product when in use. Wear comfortable clothing which does not impair freedom of movement. Do not wear clothing which is too loose and could get caught in moving parts.
- Make sure all spring pin adjustments are fully engaged after making an adjustment and before using the product.
- Children and pets must not be allowed near this machine. Supervise teenagers. This product is not a toy.
- If unsure of proper use of this product, contact Torque Fitness Customer service at: 763-754-7533 (8:30 am - 5:00 pm CST), or 1-877-TORQUE5 (1-866-664-9894). www.service@torquefitness.com

Important Safety Instructions for Assembling Equipment

- **Assistance is required. Torque Fitness recommends using more than one person to assemble this equipment.**
- This product must be assembled on a flat, level surface to assure its proper function. Locate the unit away from walls or furniture to allow easy access during assembly and use.
- Read each numbered step in Assembly and Maintenance Guide and follow the steps in sequence. Skipping ahead may result in damage to the equipment and may require components to be disassembled.
- Wear proper attire during the assembly process. Do not wear clothing which is too loose or open toed shoes.

Obtaining Service

- Do not attempt to service the product yourself except for maintenance tasks described in this manual.
- Refer to the Adjustments and Maintenance section at the back of this manual for product operation and service.
- For further information, visit our website at www.torquefitness.com or contact us at www.service@torquefitness.com
- If you call or email customer service, have the model number and serial number(s) available.

GENERAL NOTES

CAUTION: More than one person is required to assemble this unit. Do not attempt to assemble by yourself.

Unpacking the Equipment

- This product may be packaged and shipped in multiple boxes. Parts from all of the boxes are required for various steps during the assembly process.
- Carefully open each box and arrange all the parts near the area where assembly is to take place.
- **CAUTION:** Use extreme care when cutting plastic tie wraps and package banding. A wire cutter works best for protecting yourself and the parts.
- **CAUTION:** Some of the internal boxes may contain upholstery. Do not use a utility knife to open any boxes or the pads may be damaged.
- The hardware is packed in bags. Carefully open each bag and sort them per parts list on the next page.
- Before starting assembly, identify each part and hardware item as listed in the parts list on the next page. If any items are missing, contact Torque Fitness Customer service at: 763-754-7533 (8:30 am - 5:00 pm CST). www.service@torquefitness.com
- **Note:** Some items listed in the parts list may already be pre-installed on the product.

Tools Required

- Rubber mallet or hammer
- 3/4" wrench
- Ratchet with 3/4" socket
- 3/8" Allen wrench
- Allen wrench set
- Wire snips (to cut plastic tie wraps)
- Scissors or utility knife (to cut hardware bags)
- Step stool or ladder
- Tape measure

Optional Equipment

- Optional equipment may be available for this product.
- Follow the instructions included with the optional equipment to assemble it to the base product.

Assembly Tips

- In a continual effort to improve our products, specifications are subject to change.
- A 6" scale is provided at the bottom of every page. To correctly measure the bolts, measure from underneath the bolt head to the end of the bolt as illustrated below.
- Read all notes on each page before beginning that step.
- Some of the items shown in the assembly steps may already be pre-assembled.

Assembly Tips Continued

- **Note:** Some items have been hidden for assembly clarity.
- **Note:** Some pre-assembled parts may need to be temporarily removed in order to complete the step. Follow the instructions or damage to the product could occur.
- Some parts may have extra holes that will not be used. Use only the holes depicted in the instructions.
- Certain parts make reference to the right and left side of the machine. For this product, left and right is determined by facing the product.
- Provide ample space around the product for ease of assembly.
- **DO NOT** fully tighten any connections until instructed to do so. This will help insure that the alignment of all of the parts will be correct.
- Insert all bolts in the direction indicated in the instructions. Failure to do so may result in clearance issues and will degrade the aesthetics of the product.
- Carefully follow instructions for all pivot points. In general, primary rotating parts have connections that should be securely tightened, while secondary connections need to be loosen 1/4 turn.

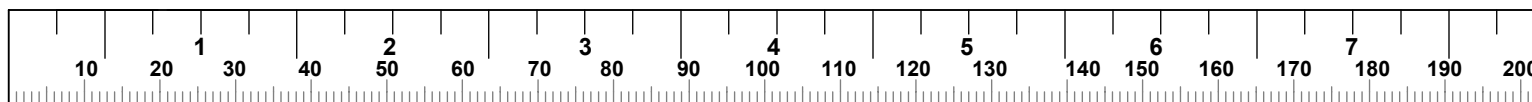

ITEM NO.	PART NUMBER	DESCRIPTION	QTY.
1	57231PA	PTD ASSY, 7.5' UPRIGHT	2
2	57237PA	PTD ASSY, 2 FT WALL MOUNT ANCHOR	4
3	2007801	WASHER, 1/2 X 1-3/4 X 4.5t	44
4	2005817	BOLT, 1/2-13 X 4-1/2" (114mm) SOCKET HEAD	14
5	2001401	NUT, 1/2-13 LK ST ZN	27
6	5442801	WLDMT, 4' SINGLE CROSS	1
7	2001101	WASHER, FLAT 3/8 SAE ST ZN	16
8	2031101	SCREW, 3/8" LAG X 2.5"L CLEAR ZINC	16
9	5720501	PLATE, HEADER	2
10	5720401	PLATE, WALL MOUNT BACKING	4
11	2001301	WASHER, FLAT 1/2 SAE ST ZN	30
12	2006802	BOLT, 1/2-13 X 3/4" (19mm) SOCKET HEAD W/NP	8
13	56975PA	PTD ASSY, LEFT BAR SUPPORT	1
14	56967PA	PTD ASSY, RIGHT BAR SUPPORT	1
15	57239PA	PTD ASSY, 7.5U VERTICAL WEIGHT STORAGE WM	2
16	2005812	BOLT, 1/2-13 X 3-1/4" (83mm) SOCKET HEAD	8
17	54745PA	PTD ASSY, LEFT BAR CATCH	1
18	54748PA	PTD ASSY, RIGHT BAR CATCH	1
19	55478PA	PTD ASSY, XDSA LEFT	1
20	55481PA	PTD ASSY, XDSA RIGHT	1

ITEM NO.	PART NUMBER	DESCRIPTION	QTY.
21	54705PA	PTD ASSY, BALL TARGET	1
22	2005824	BOLT, 1/2-13 X 6-1/4" (159mm) SOCKET HEAD	2
23	55934PA	PTD ASSY, UBPA LEFT	1
24	55935PA	PTD ASSY, UBPA RIGHT	1
25	5708201	BPLATE, XERT MOUNTING	1
26	5715701 FOR ASSY INST	FINAL ASSY, ENDLESS ROPE TRAINER	1
27	2008904	BOLT, 1/2-13 X 1-1/4" (32mm) HEX HEAD	4
28	2021001	NUT, 1/2-13 LK ST ZN	4
29	5676701	PLATE, MOUNTING	1
30	2008917	BOLT, 1/2-13 X 4-1/2" (114mm) HEX HEAD	4
31	56260PA	PTD ASSY, UNIVERSAL HEAVY BAG MOUNT	1
32	HBT-100LB-45.4KG	HEAVY BAG, TORQUE 100LB (45.4KG)	1
33	55782PA	PTD ASSY, BATTLE ROPE ANCHOR	1
34	5521501	ASSY, GROUND ROTATIONAL TRAINER	1
35	5582201	WLDMT, LBPA LEFT	1
36	5582701	WLDMT, LBPA RIGHT	1
37	5621301	ASSY, GROUND ROTATIONAL TRAINER	1
38	2005816	BOLT, 1/2-13 X 4-1/4" (108mm) SOCKET HEAD	5
39	57412PA	DOUBLE PLAY - BAR STORAGE/BATTLE ROPE ANCHOR	1
40	5745101	WLDMT, DOUBLE PLAY ADAPTER	1
41	2005811	BOLT, 1/2-13 X 3" (76mm) SOCKET HEAD	6
42	57822PA	PTD ASSY, VERTICAL DUMBBELL STORAGE	1
43	57819PA	PTD ASSY, 5 PAIR VERTICAL DUMBBELL STORAGE	1

TABLE OF CONTENTS:

- Warnings: Page 2
- General Notes: Page 3
- Wall Rack Assembly: Page 5, 6, 7 & 14
- Wall anchor mount: Page 8
- Wall header/footer mount: Pages 9 -10
- Optional wall header plate mount: Pages 11 - 13
- Optional Attachments: Pages 15 - 33
- Maintenance/notices: Page 34

NOTES:

Assembly steps 1, 2A, 2B & 6 show steps to assemble the 3.0 base system. Additional assembly steps for optional attachments, are shown in subsequent steps and are listed as "optional"

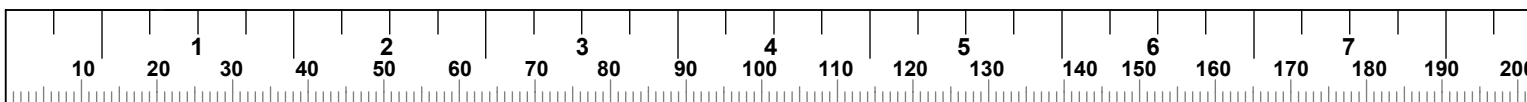

STEP 1

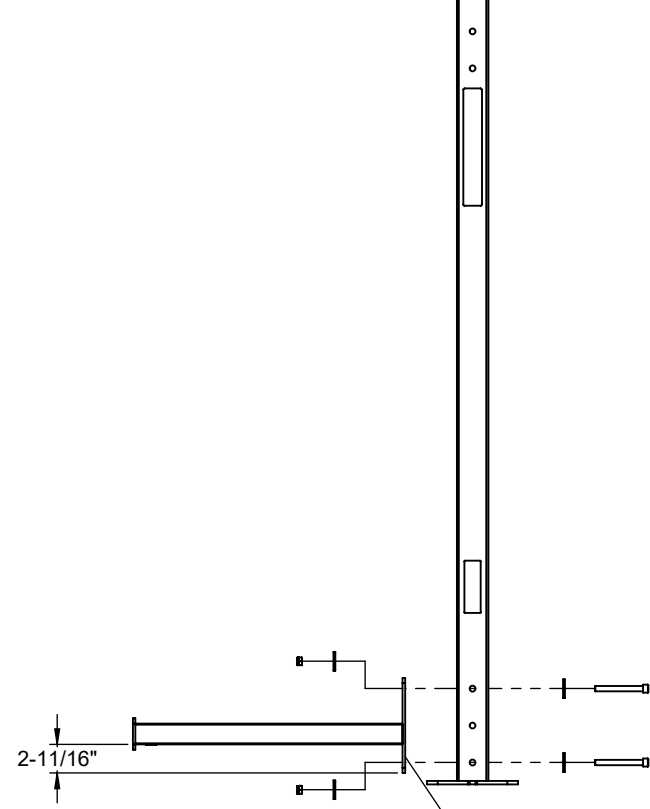
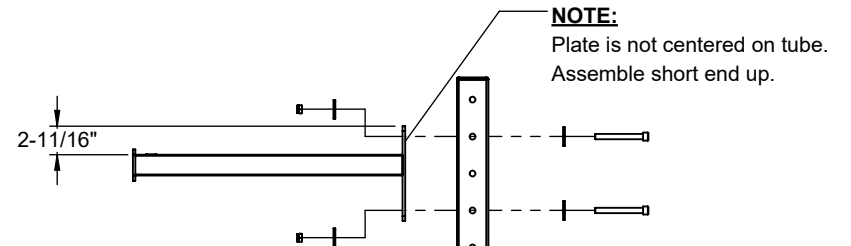
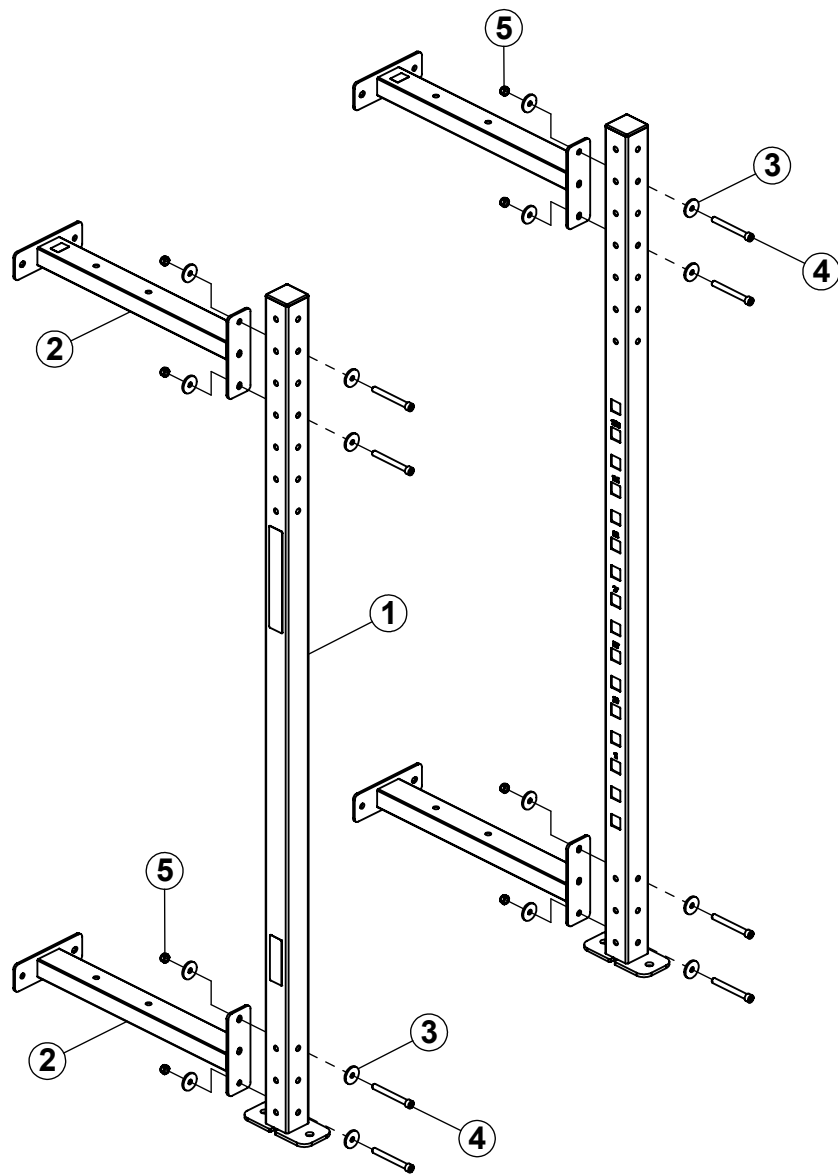

SIDE VIEW

NOTE:

LOOSELY tighten all bolt connections in this step.

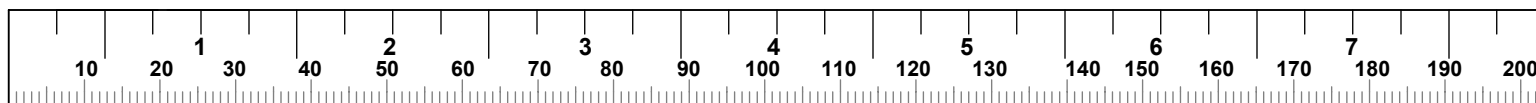

STEP 2

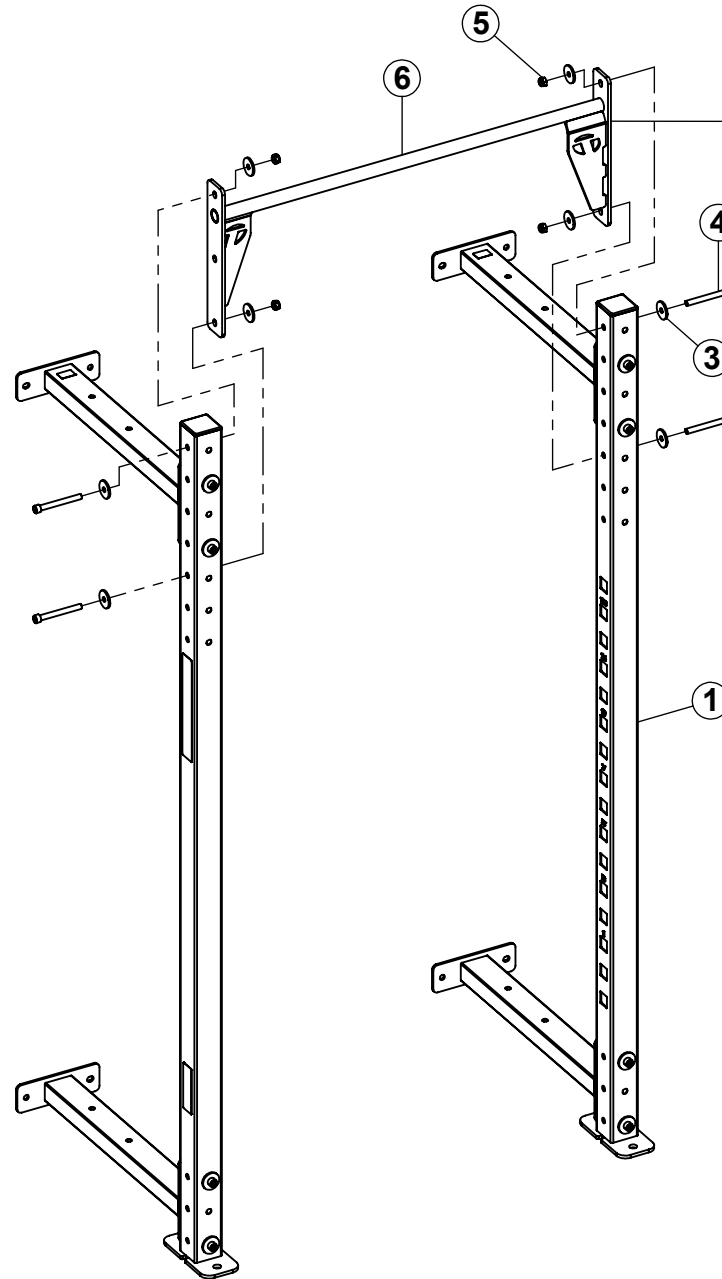
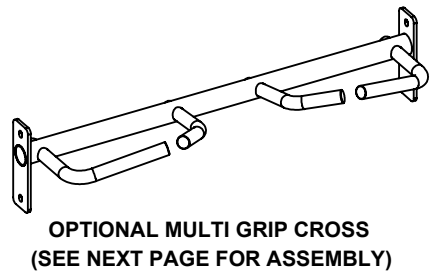
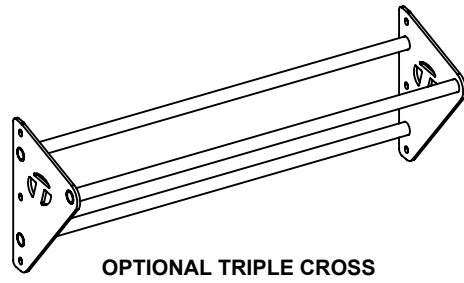
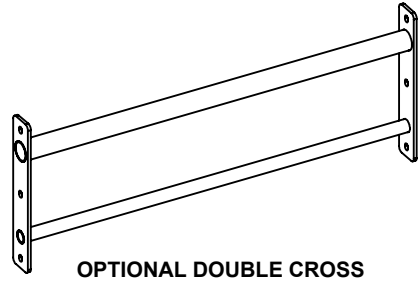
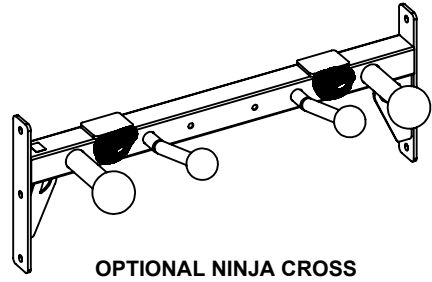

NOTE:

THE STANDARD SINGLE CROSS IS SHOWN FOR ASSEMBLY. THE OPTIONAL NINJA CROSS, DOUBLE CROSS AND TRIPLE CROSS ASSEMBLE TO THE UNIT THE EXACT SAME WAY.

IF YOU PURCHASED THE OPTIONAL MULTI GRIP CROSS, PLEASE REFER TO NEXT PAGE FOR ASSEMBLY.

NOTE:

SECURELY tighten all bolts in this step and previous step.

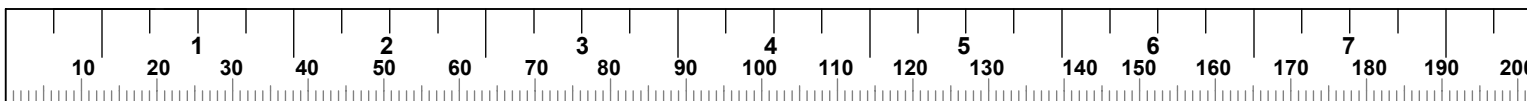

STEP 2B (OPTIONAL MULTI GRIP CROSSES)

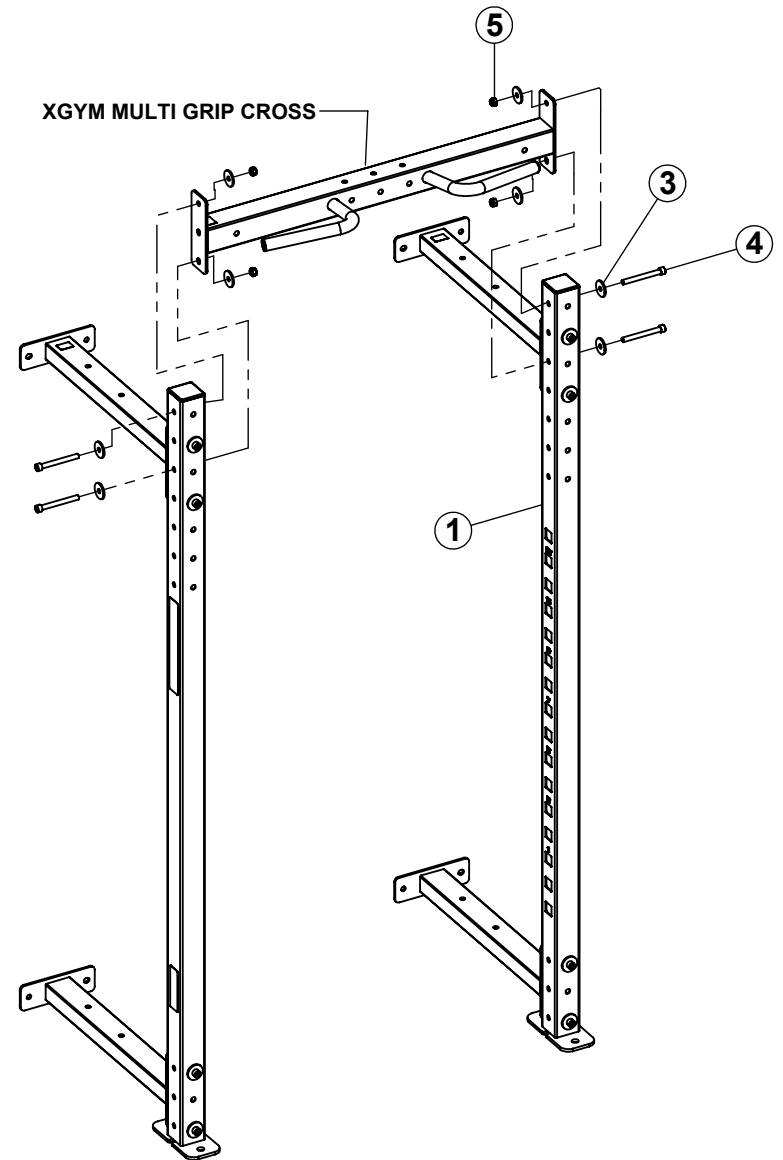
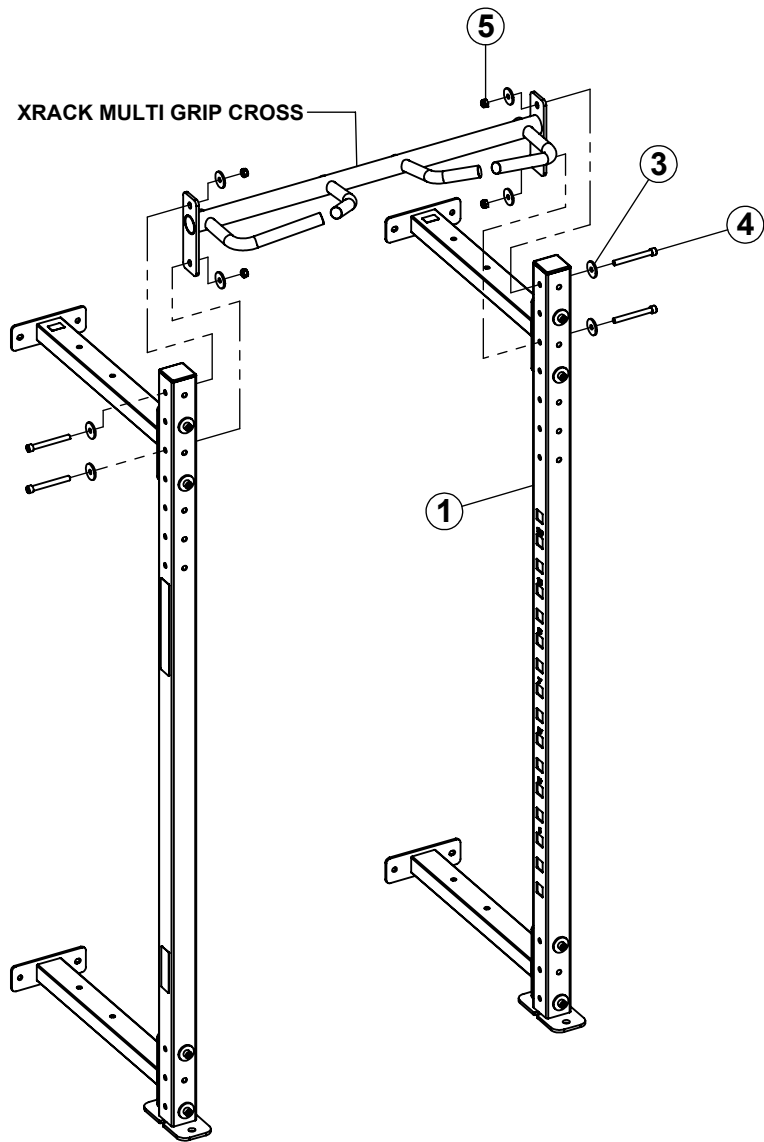

NOTE:

SECURELY tighten bolt connections in this step and previous step.

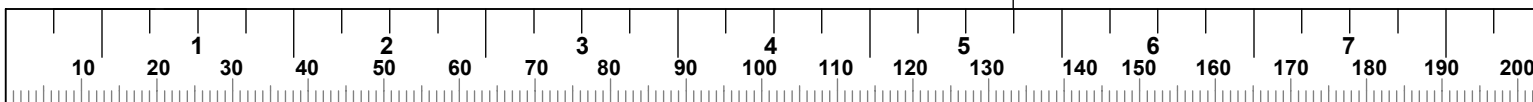

STEP 3 (WALL ANCHOR MOUNT)

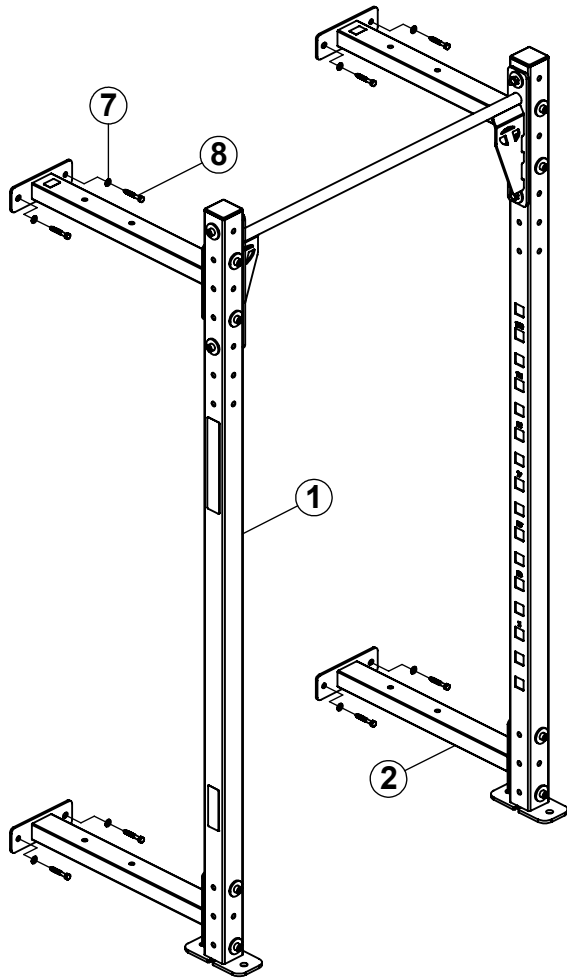

WARNING:
THE UPPER AND LOWER WALL MOUNT ANCHORS **MUST**
BE ANCHORED TO THE WALL USING EIGHT WALL ANCHORS
SUITABLE FOR THAT PARTICULAR WALL CONSTRUCTION.

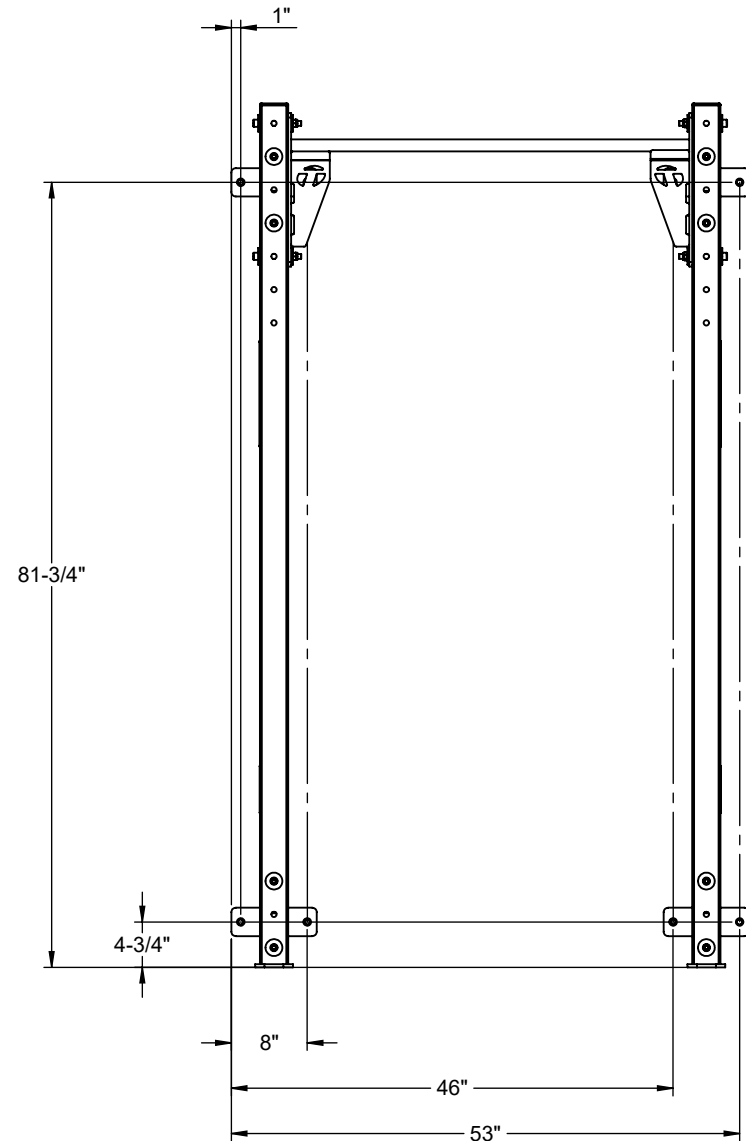

NOTES:

The images above show how to attach the rack to the wall using wall anchors. The wall anchors used will depend on the wall construction.

NOTE: All eight anchoring locations must be used. The pull-out strength of the anchoring hardware used must be equal to or greater than 200 lbs. (91 kg) each.

SECURELY tighten all bolt connections in this step.

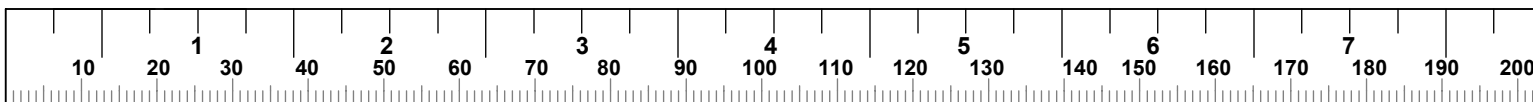

STEP 4A (HEADER/FOOTER MOUNT)

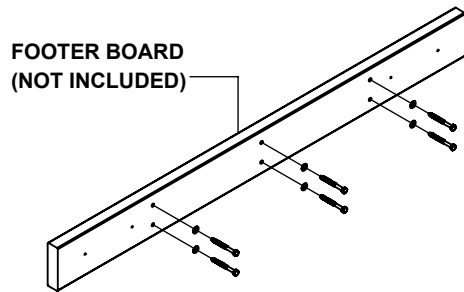
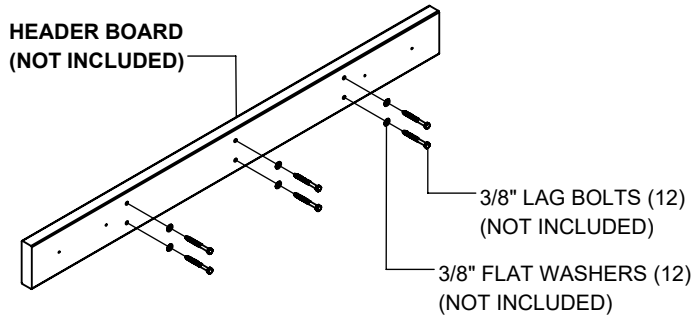

WARNING:

THE HEADER AND FOOTER **MUST** BE ANCHORED TO THE WALL USING TWELVE WALL ANCHORS SUITABLE FOR THAT PARTICULAR WALL CONSTRUCTION.

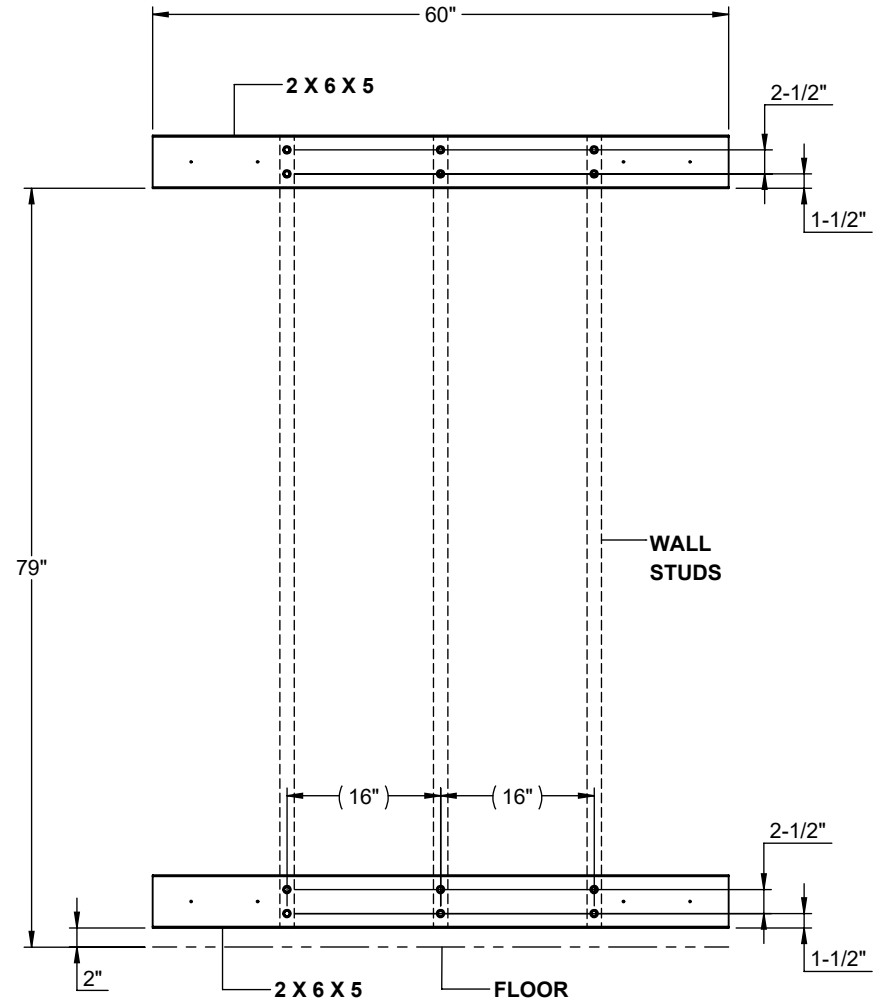

NOTES:

The images above show how to attach a header and footer board to a typical wall with wood studs spaced 16" on center. The anchors used will depend on the wall construction. **NOTE: All twelve anchoring locations must be used.** The pull-out strength of the anchoring hardware used must be equal to or greater than 200 lbs. (91 kg) each.

SECURELY tighten all bolt connections in this step.

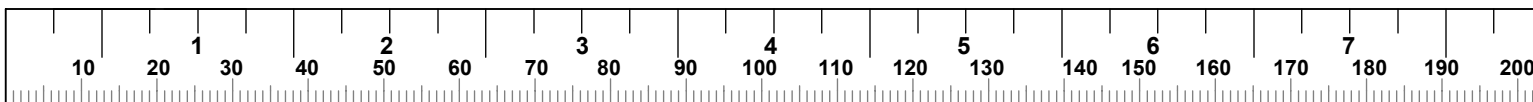

STEP 4B (HEADER/FOOTER MOUNT)

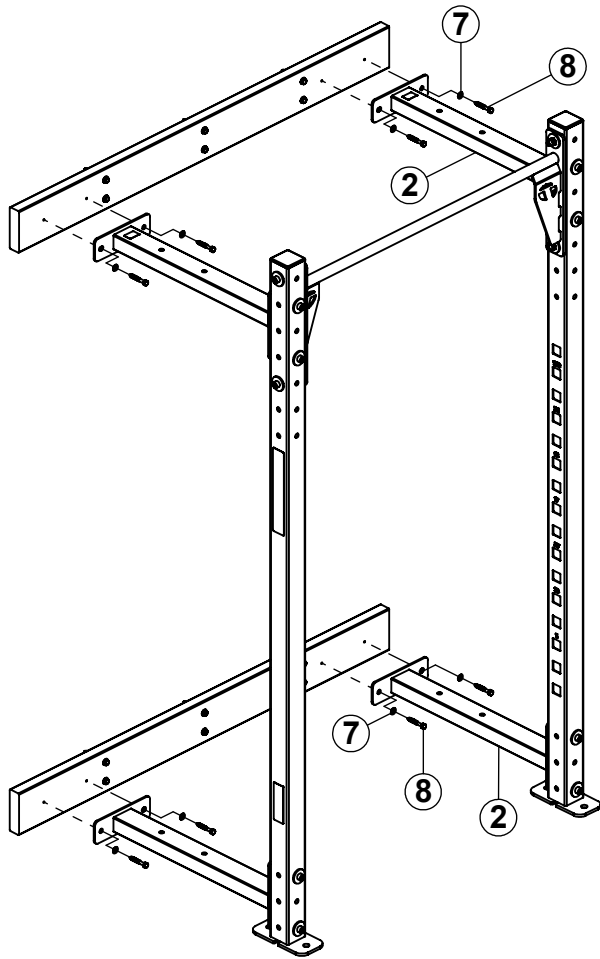

WARNING:

THE RACK MUST BE ANCHORED TO THE HEADER AND FOOTER BOARDS USING ALL EIGHT WALL ANCHORS.

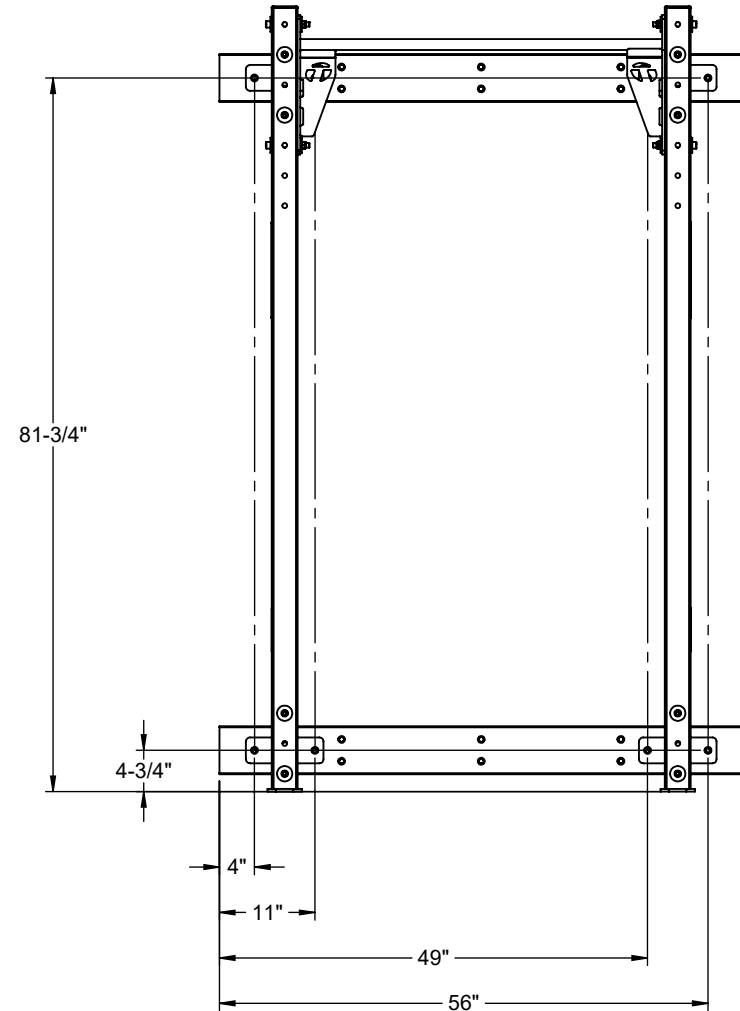

NOTES:

The images above show how to attach the rack to the header and footer boards from previous step using 3/8" lag bolts. **NOTE: All eight anchoring locations must be used.** The pull-out strength of the anchoring hardware used must be equal to or greater than 200 lbs. (91 kg) each.

SECURELY tighten all bolt connections in this step.

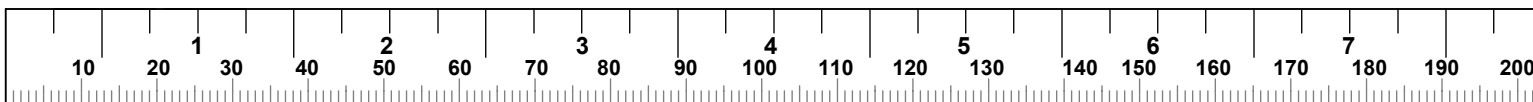

STEP 5A (OPTIONAL HEADER PLATE MOUNT)

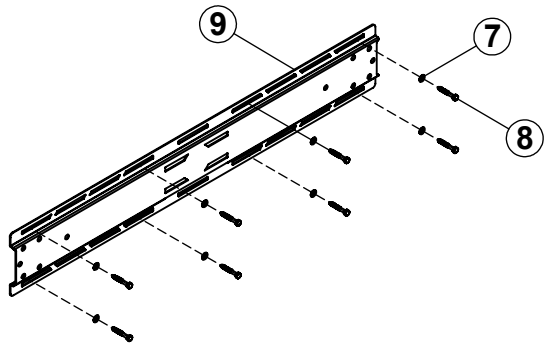
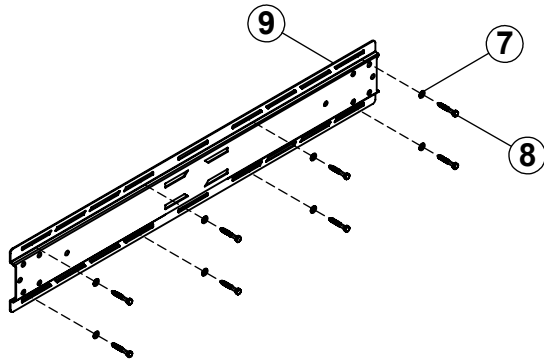

WARNING:

THE UPPER AND LOWER HEADER PLATE MOUNTS **MUST** BE ANCHORED TO THE WALL USING 16 WALL ANCHORS SUITABLE FOR THAT PARTICULAR WALL CONSTRUCTION.

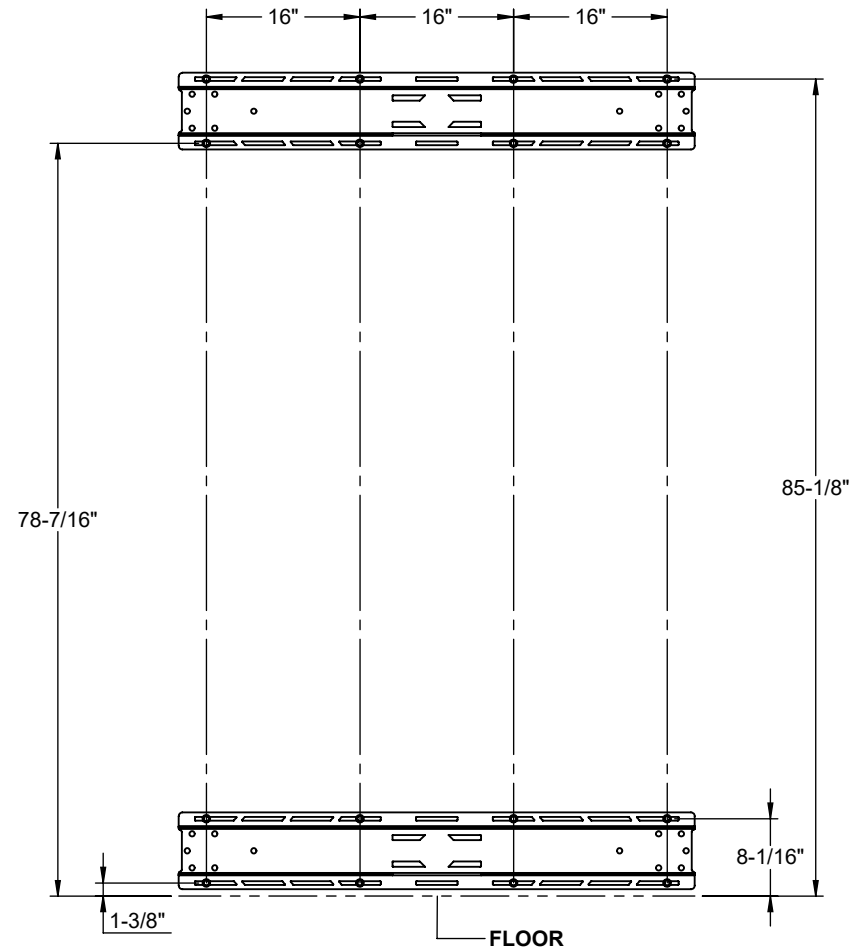

NOTES:

The images above show the anchoring hardware used for attaching the HEADER PLATE MOUNT to a typical wall with wood studs spaced 16" on center. The anchors used will depend on the wall construction.

NOTE: All sixteen anchoring locations must be used. The pull-out strength of the anchoring bolts used must be equal to or greater than 200 lbs. (91 kg)

SECURELY tighten all bolt connections in this step.

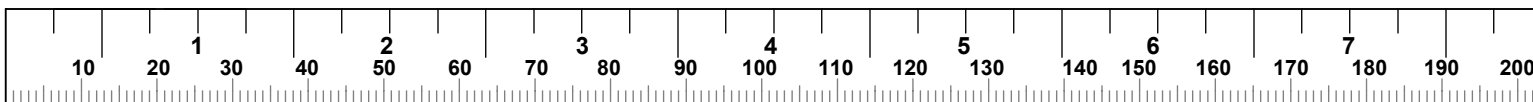

STEP 5B (OPTIONAL HEADER PLATE MOUNT)

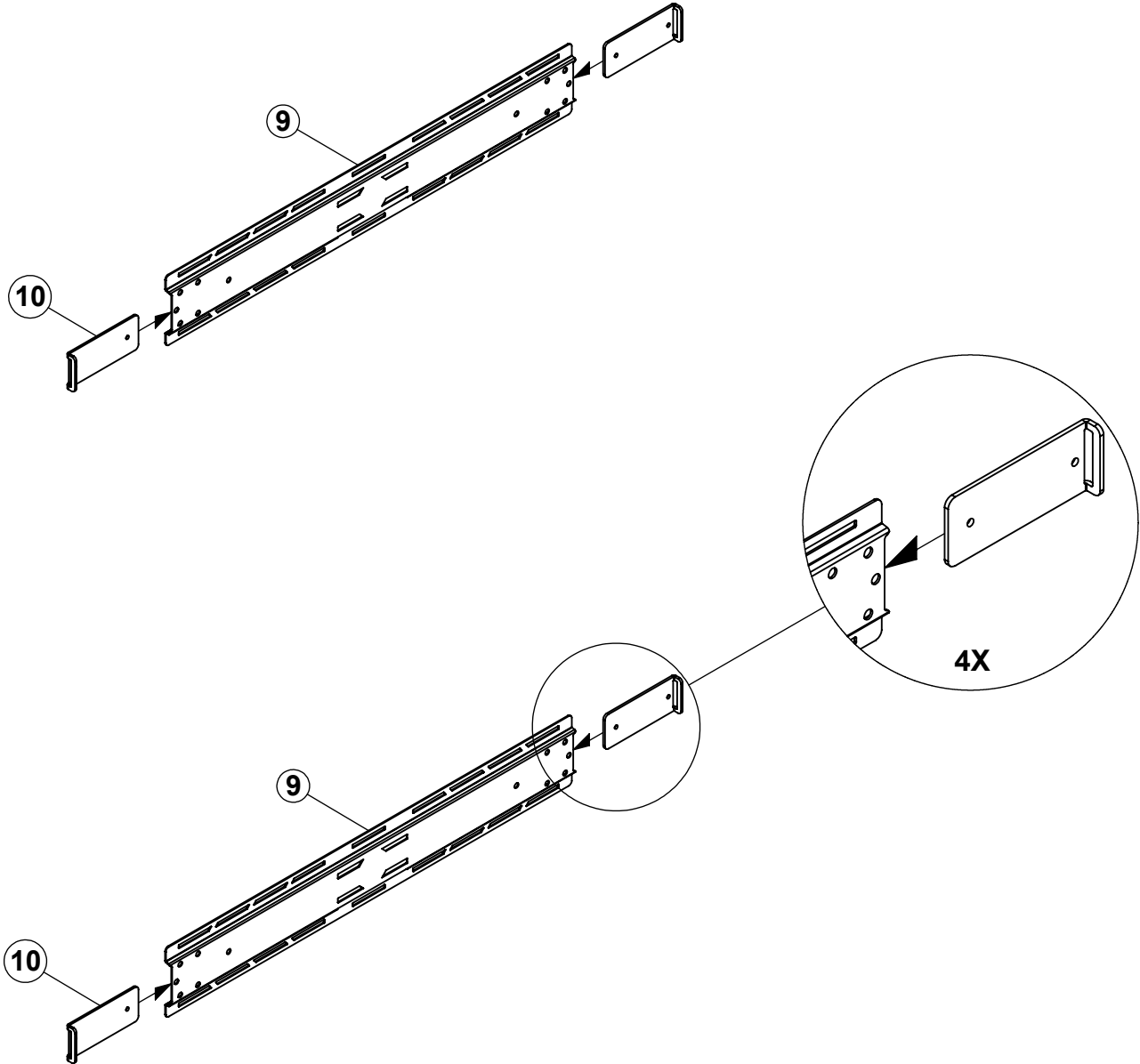

STEP 5C (OPTIONAL HEADER PLATE MOUNT)

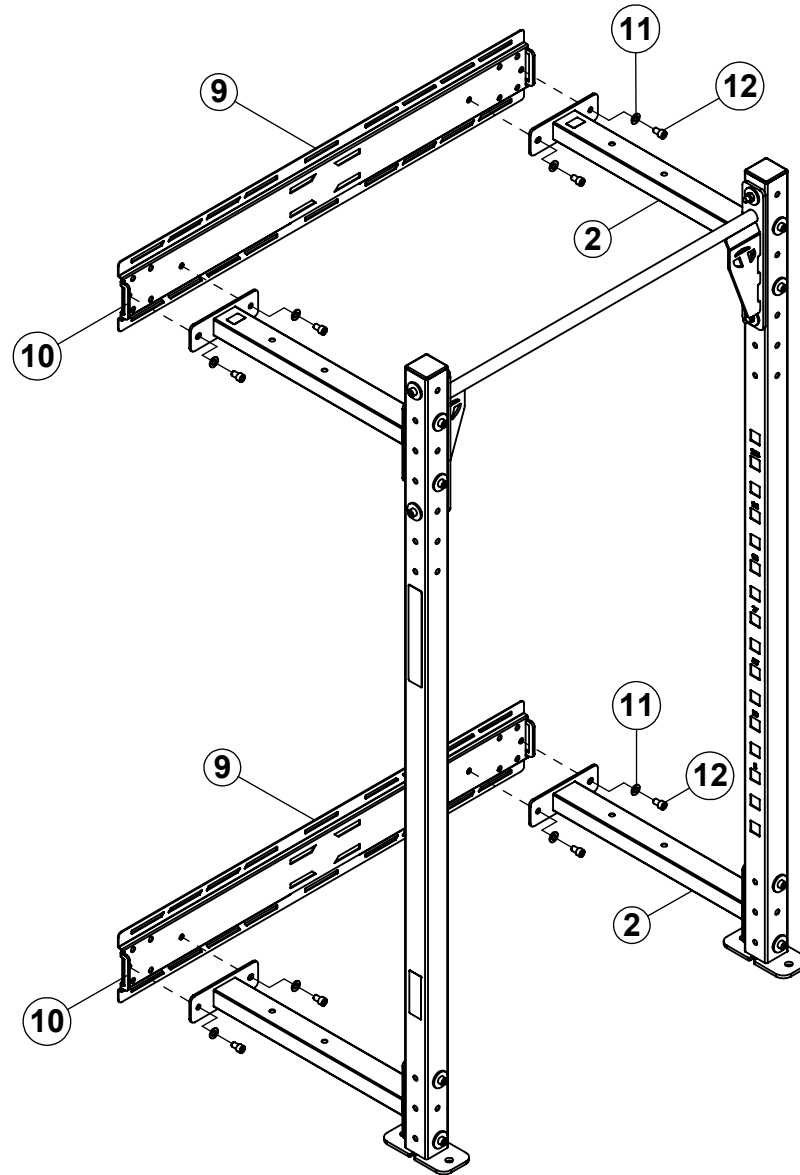

NOTES:

SECURELY tighten all bolt connections in this step.

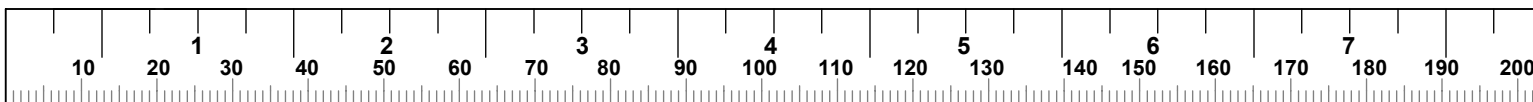

STEP 6

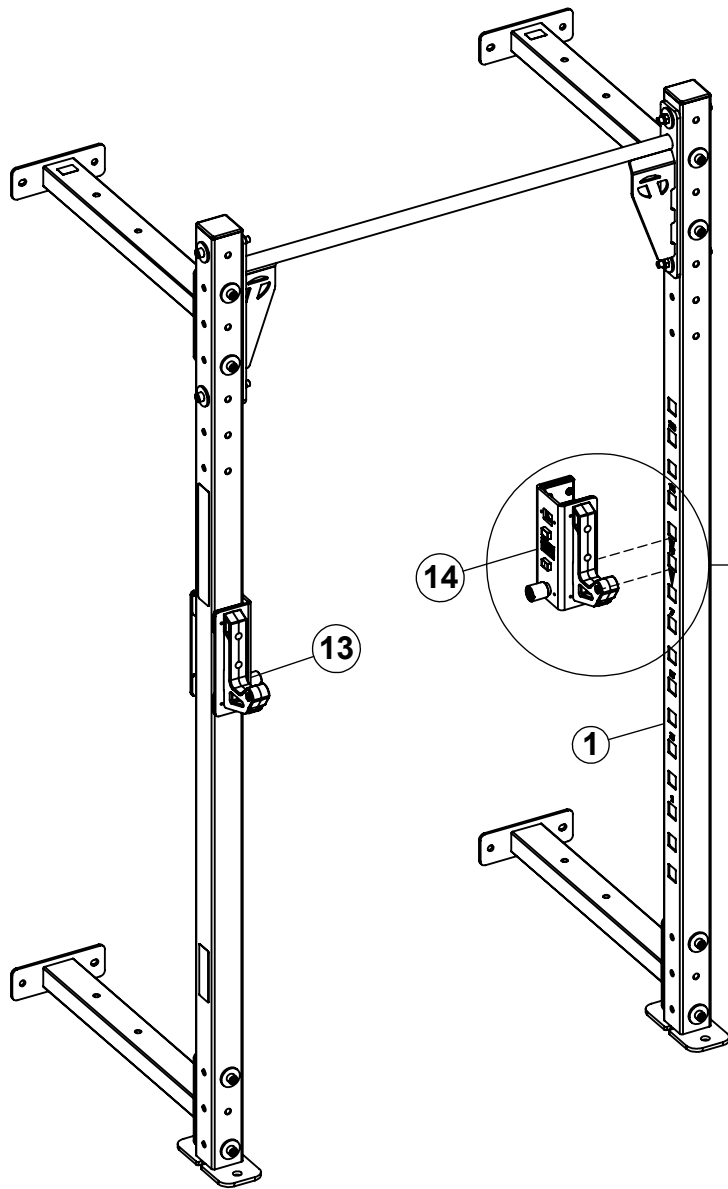

INSERT BAR SUPPORTS INTO
DESIRED SLOTS ON UPRIGHTS.
PUSH DOWN TO LOCK IN PLACE

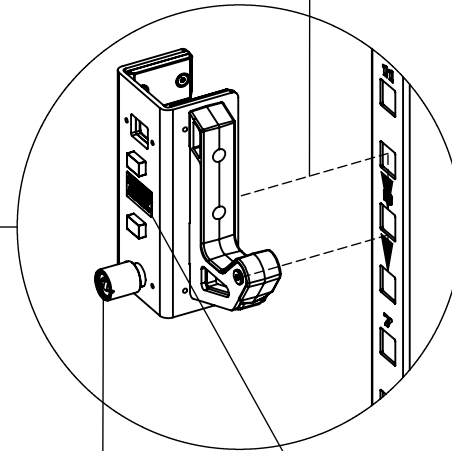

NOTE:
WARNING LABEL

TO REMOVE BAR SUPPORTS FROM
UPRIGHTS, PULL SPRING PIN OUT TO
UNLOCK. LIFT UP AND PULL OUT

STEP 7

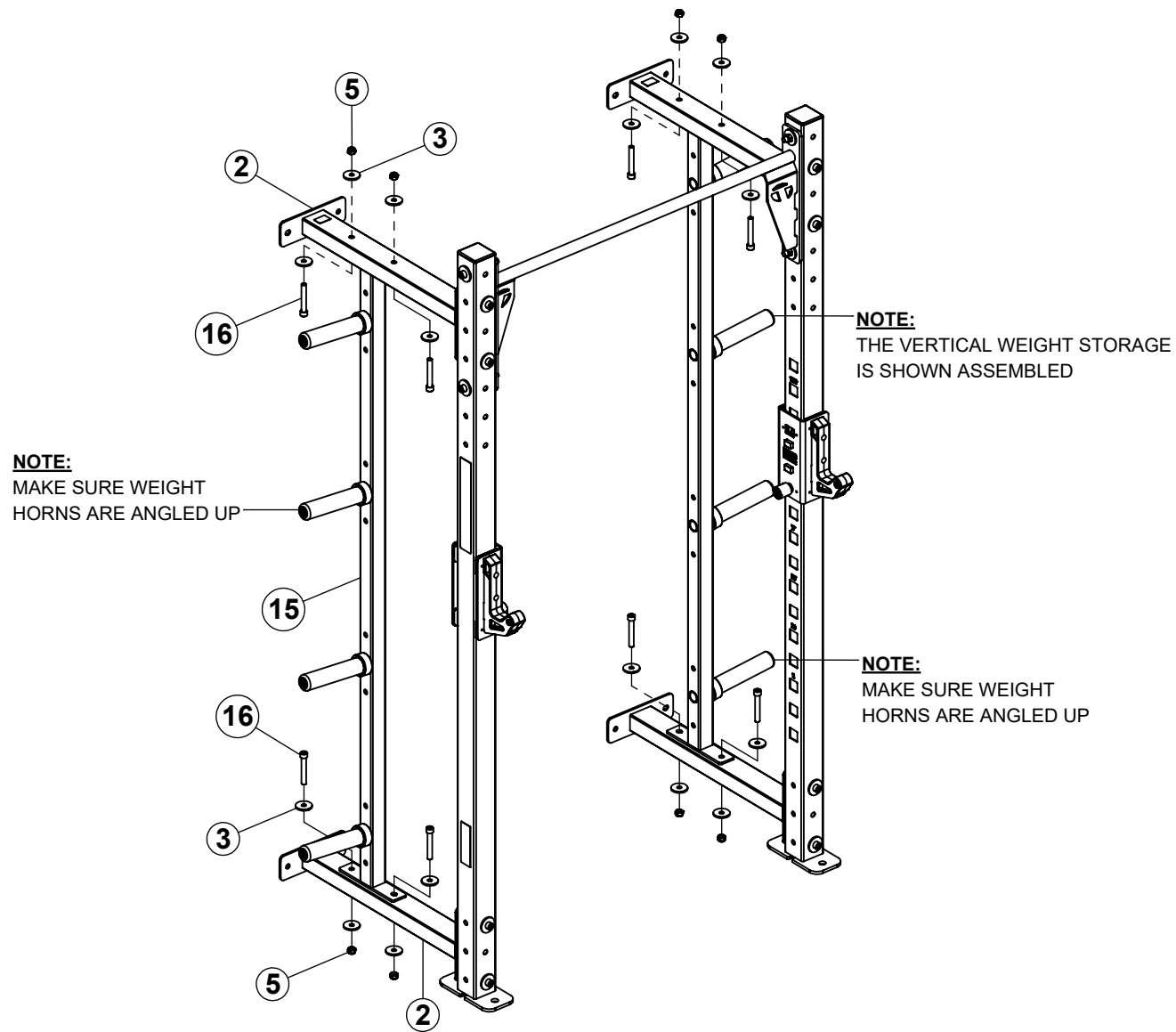

NOTE:

Loosen frame connections to assemble this step. Then **SECURELY** tighten all bolt connections.

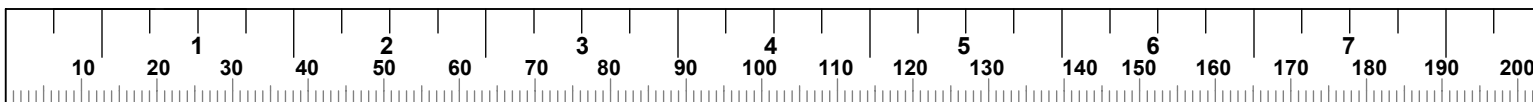

STEP 8 (OPTIONAL BAR CATCHES)

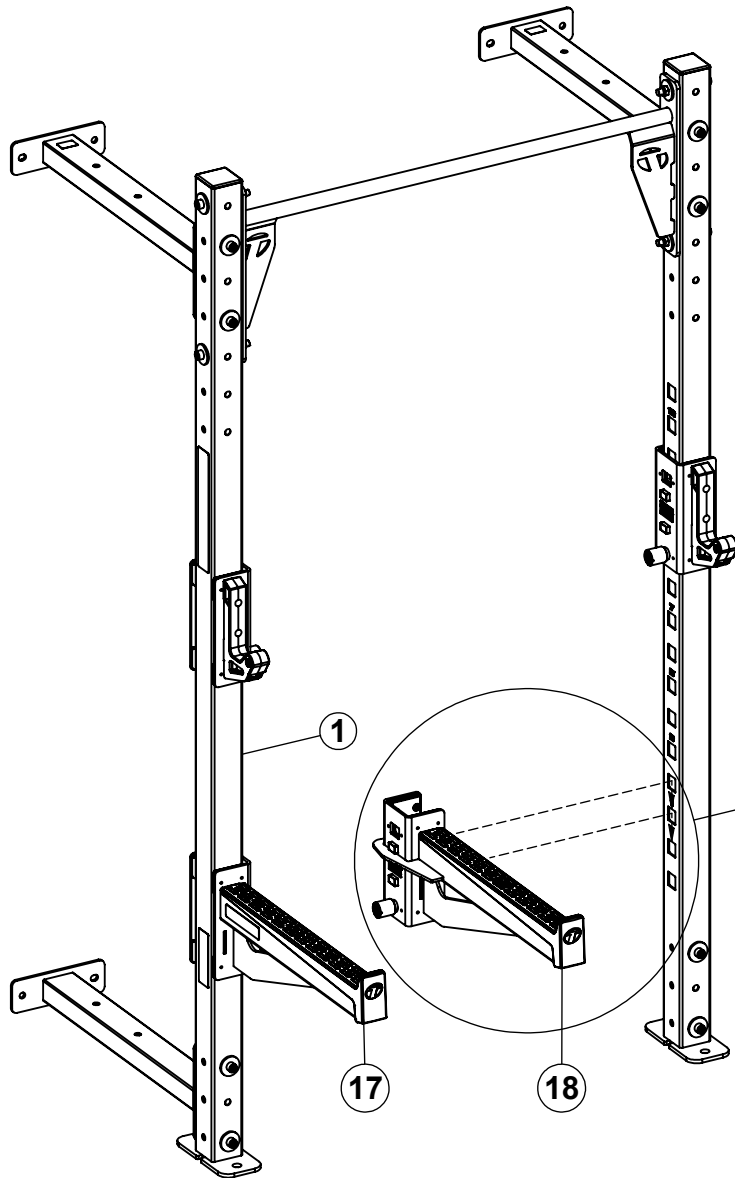

INSERT BAR CATCHES INTO
DESIRED SLOTS ON UPRIGHTS.
PUSH DOWN TO LOCK IN PLACE

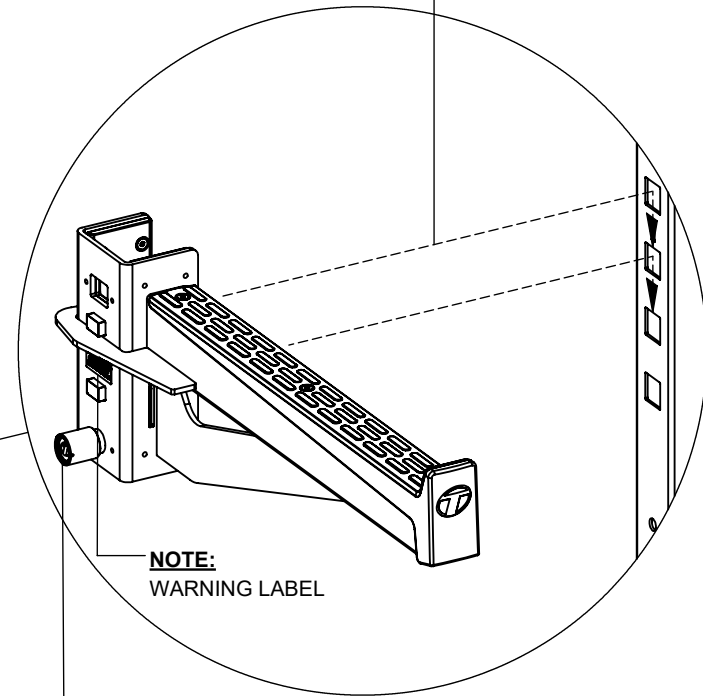

NOTE:
WARNING LABEL

TO REMOVE BAR CATCHES FROM
UPRIGHTS, PULL SPRING PIN OUT TO
UNLOCK. LIFT UP AND PULL OUT

STEP 9 (OPTIONAL DIP ATTACHMENT)

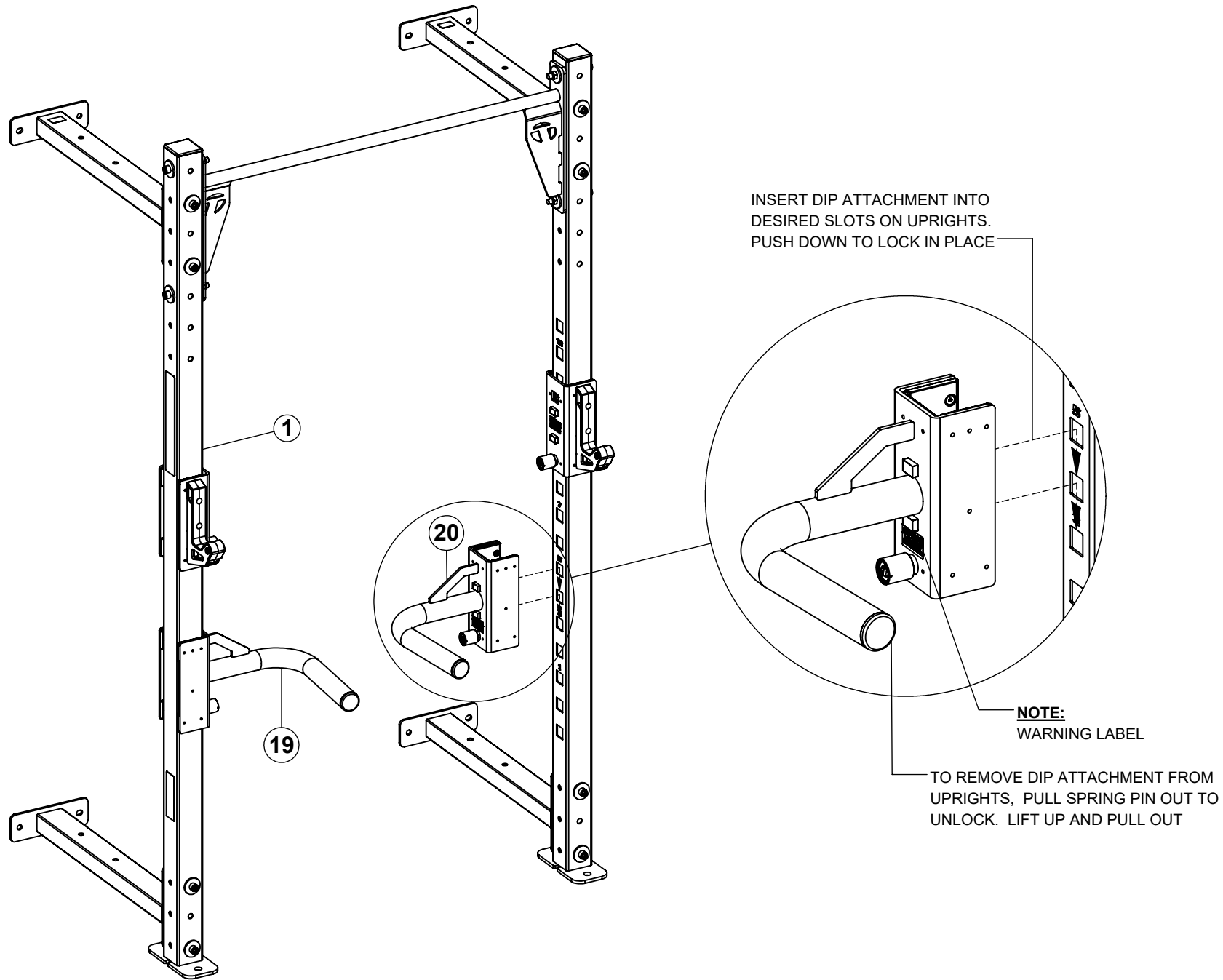

STEP 10A & 10B (OPTIONAL BALL TARGET)

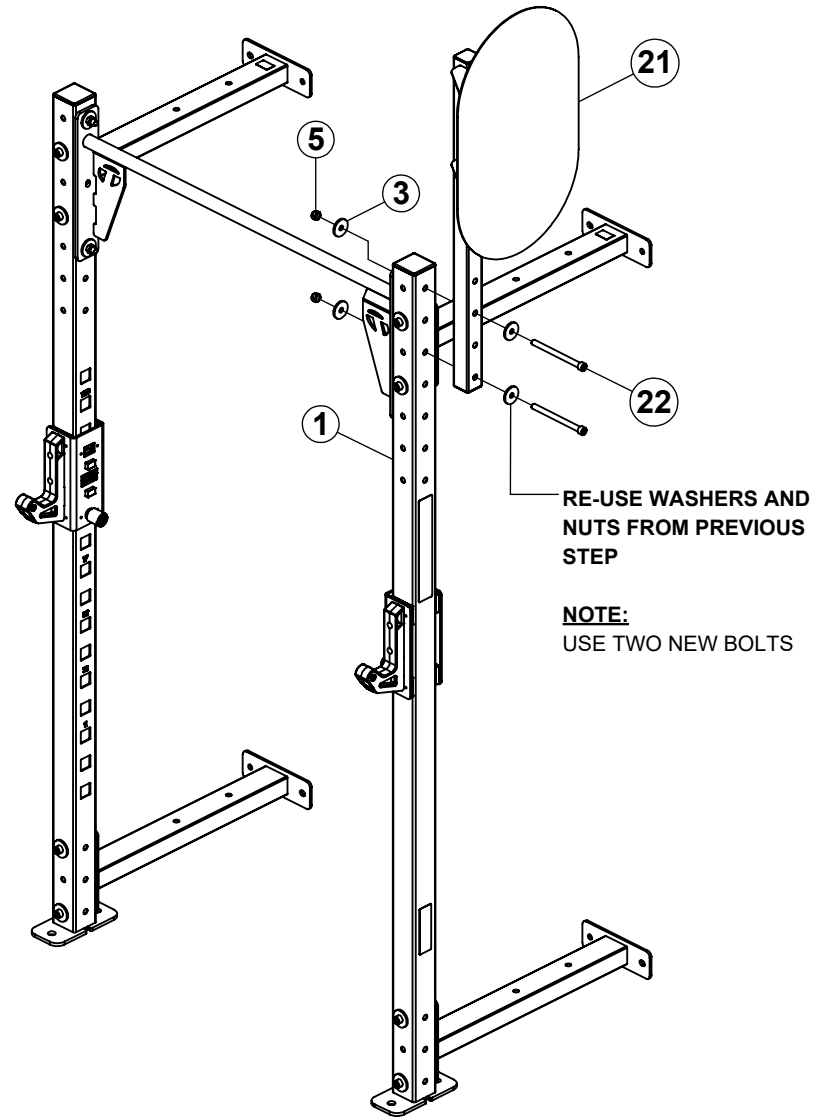
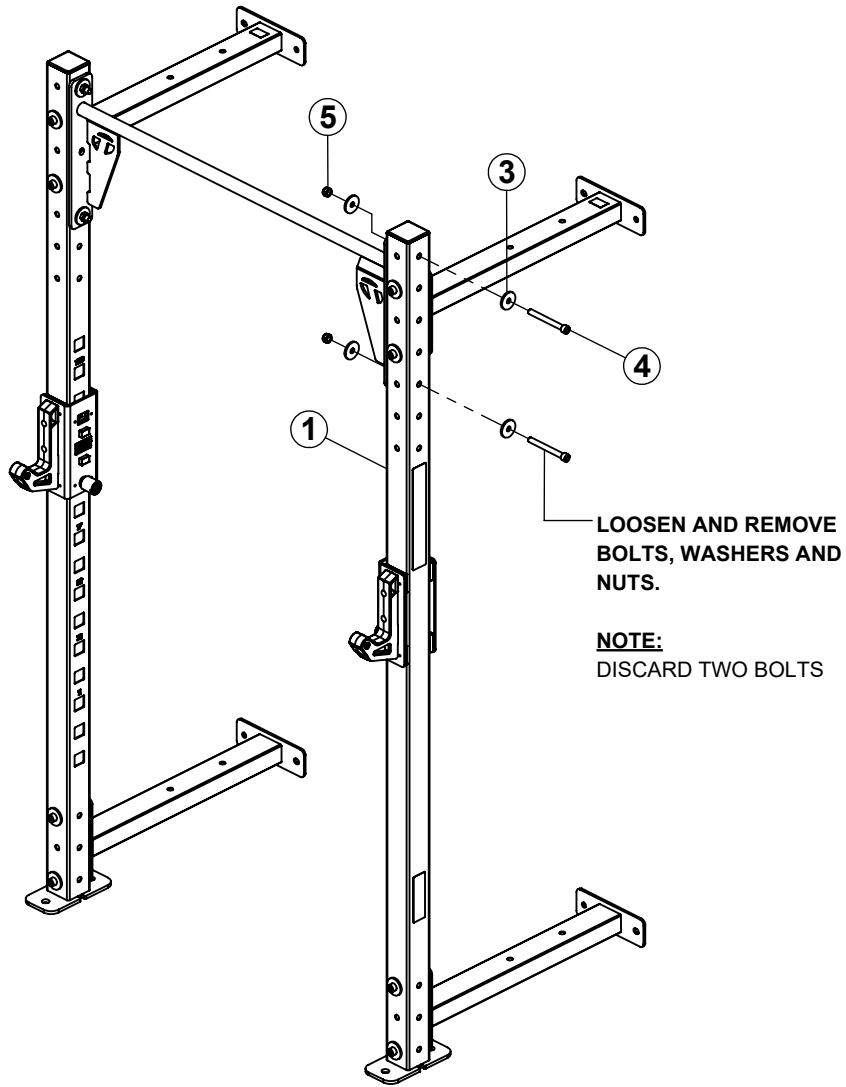

NOTE:

SECURELY tighten all bolt connections in this step.

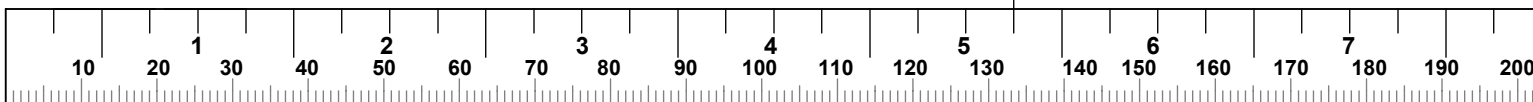

STEP 11A & 11B (OPTIONAL UPPER BAND PEG ATTACHMENT)

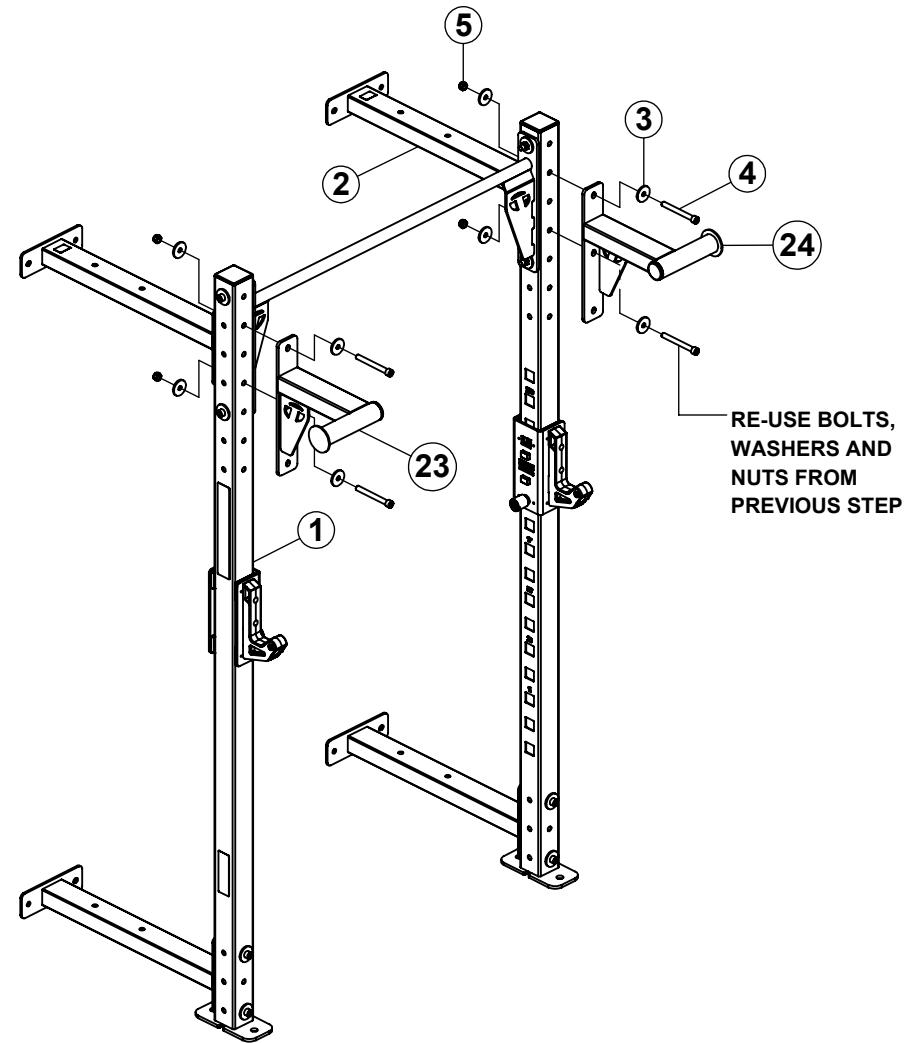
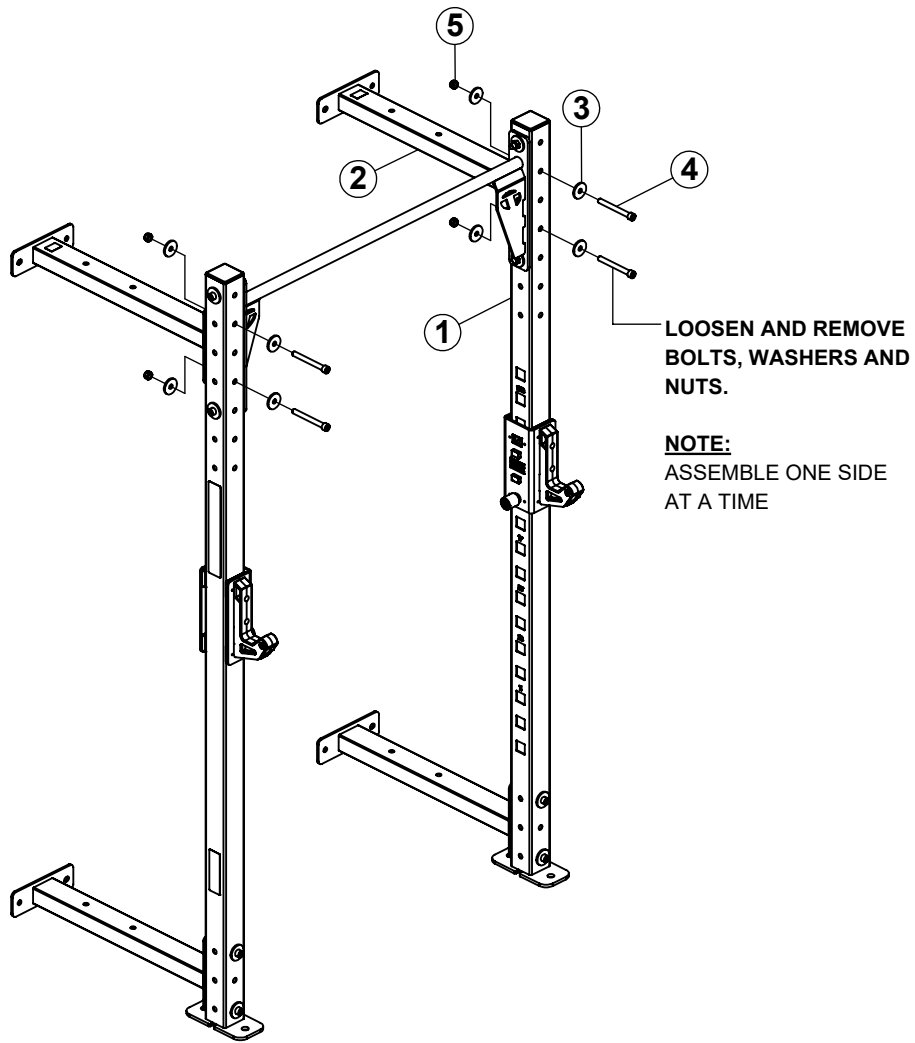

NOTE:

SECURELY tighten all bolt connections in this step.

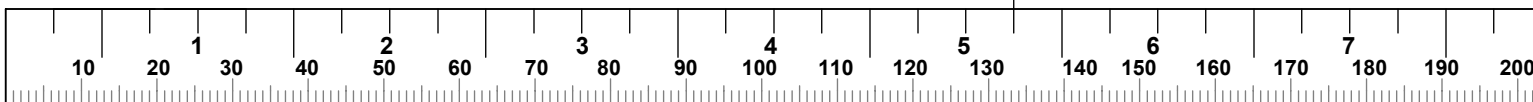

STEP 12A & 12B (OPTIONAL ENDLESS ROPE TRAINER, WITH VERTICAL WEIGHT STORAGE)

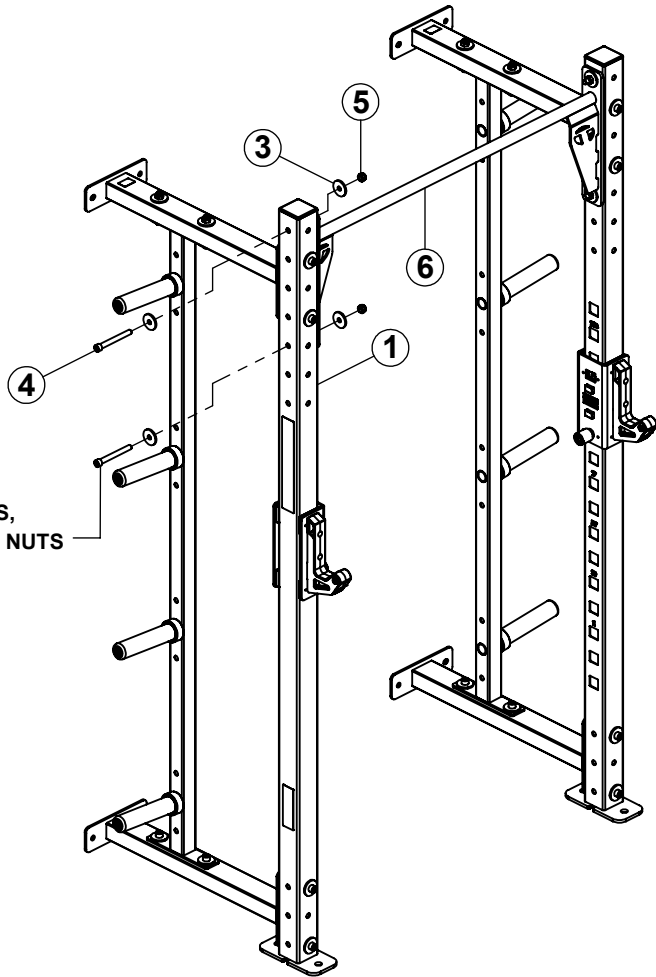

LOOSEN AND REMOVE BOLTS, WASHERS AND NUTS

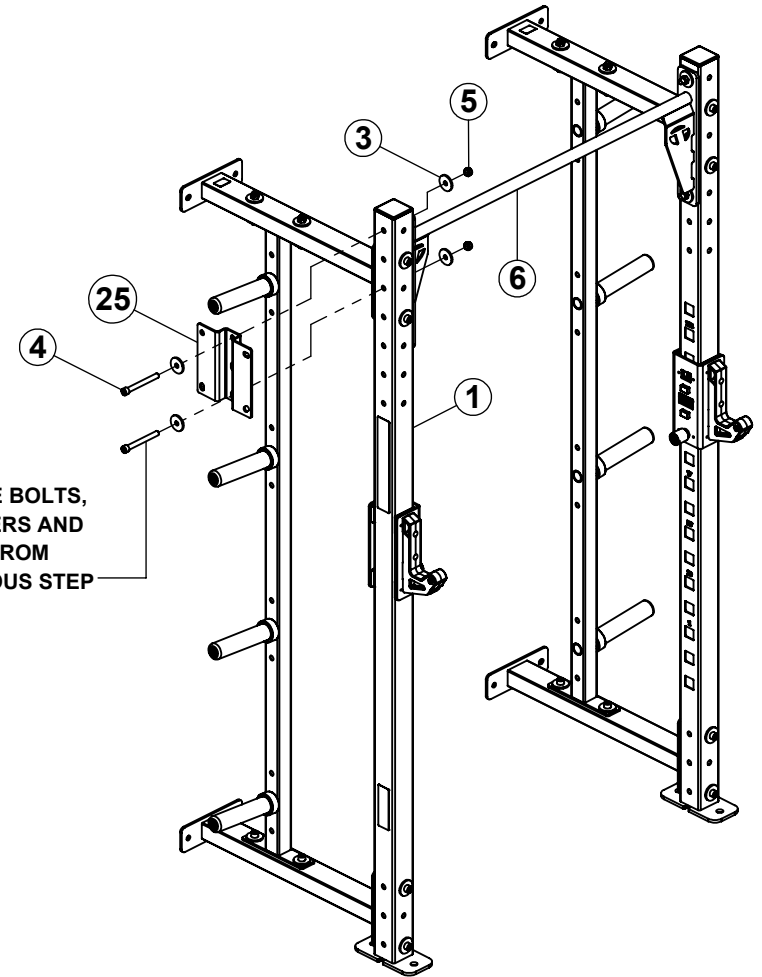

RE-USE BOLTS, WASHERS AND NUTS FROM PREVIOUS STEP

NOTE:

SECURELY tighten all bolt connections in this step.

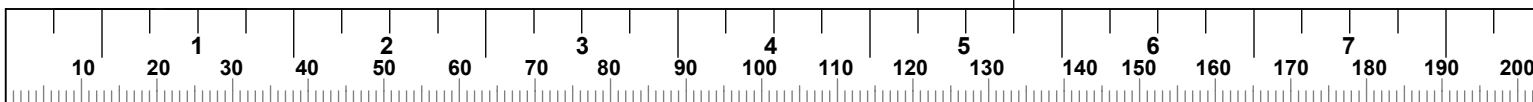

**STEP 12C (OPTIONAL ENDLESS ROPE TRAINER,
WITH VERTICAL WEIGHT STORAGE)**

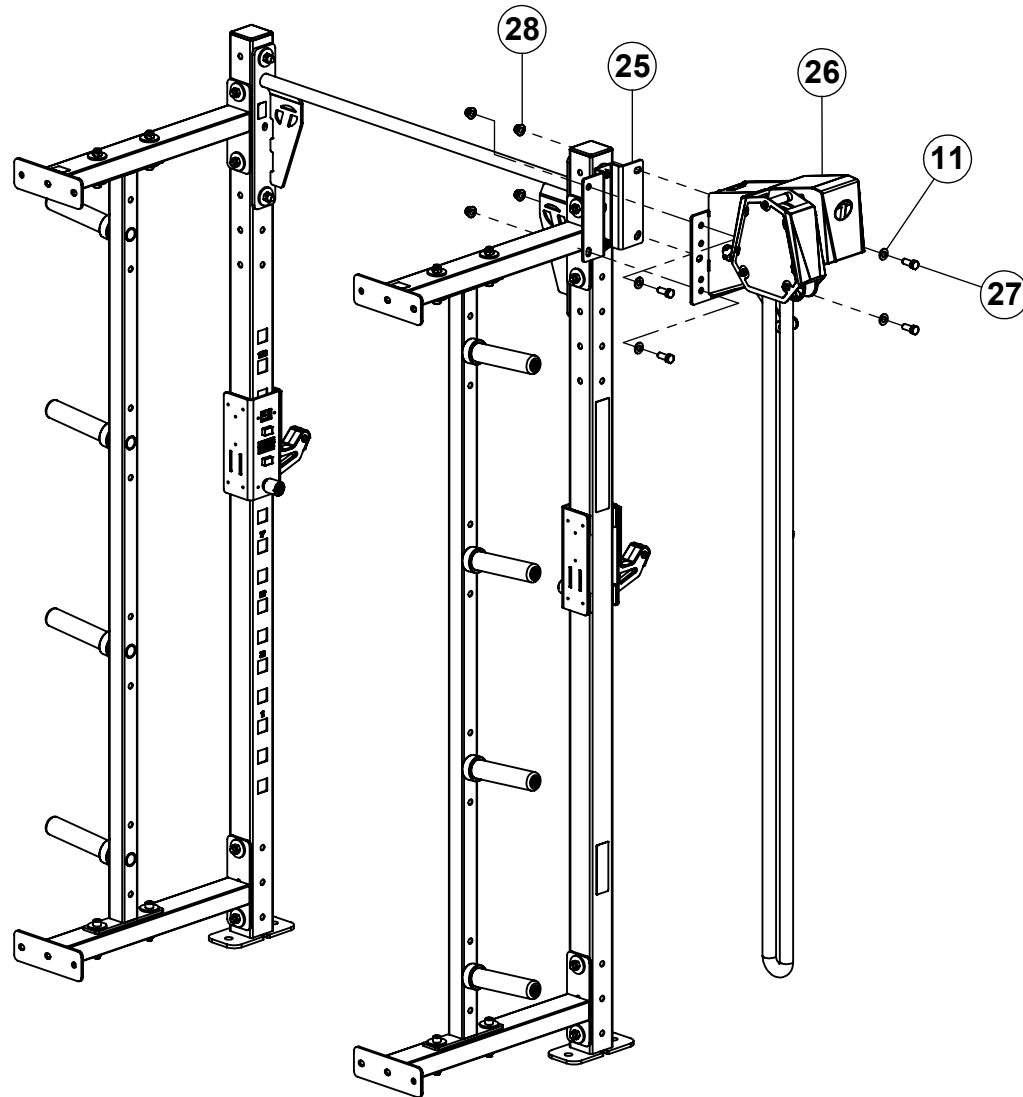

NOTE:

SECURELY tighten all bolt connections in this step.

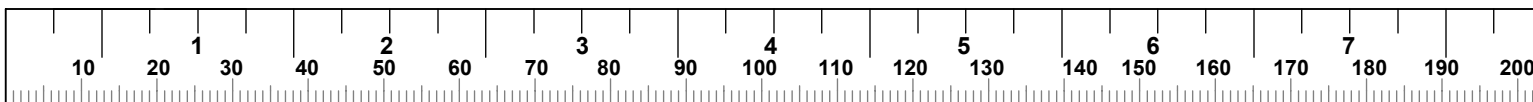

STEP 13 (OPTIONAL ENDLESS ROPE TRAINER, WITHOUT VERTICAL WEIGHT STORAGE)

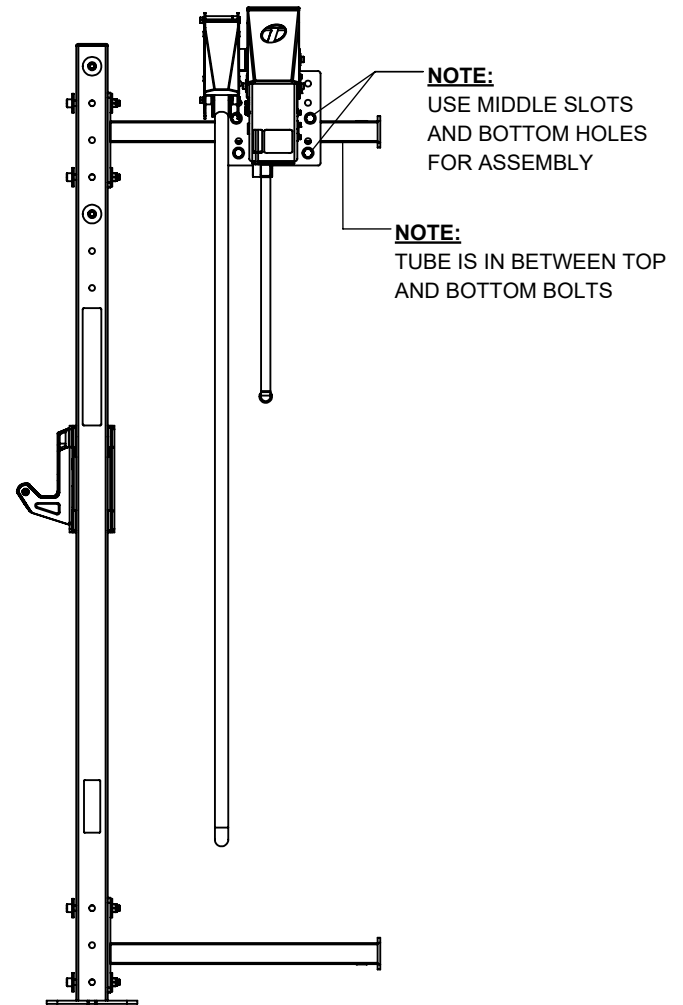
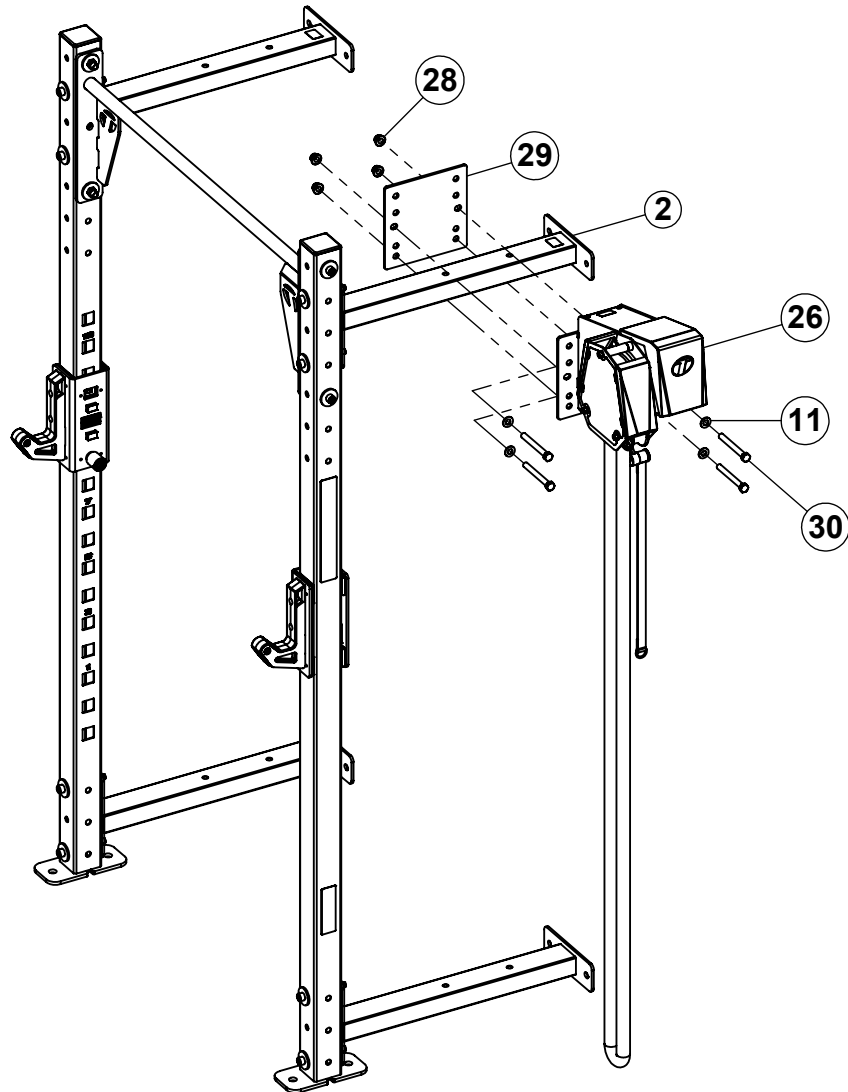

NOTE:

SECURELY tighten all bolt connections in this step.

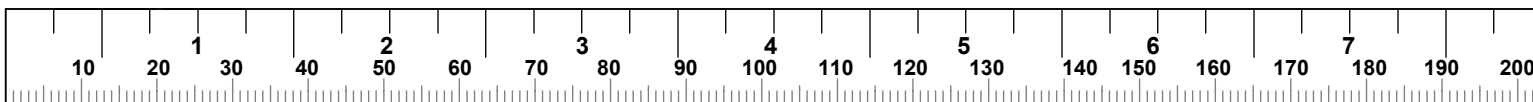

STEP 14A & 14B (OPTIONAL UNIVERSAL HEAVY BAG MOUNT, WITH VERTICAL WEIGHT STORAGE)

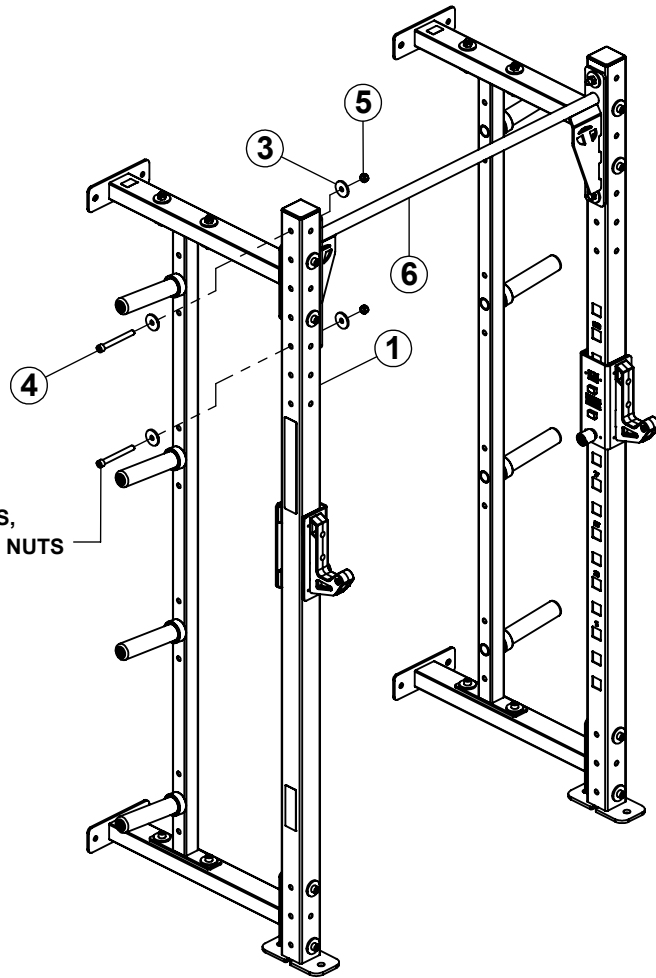

LOOSEN AND REMOVE BOLTS, WASHERS AND NUTS

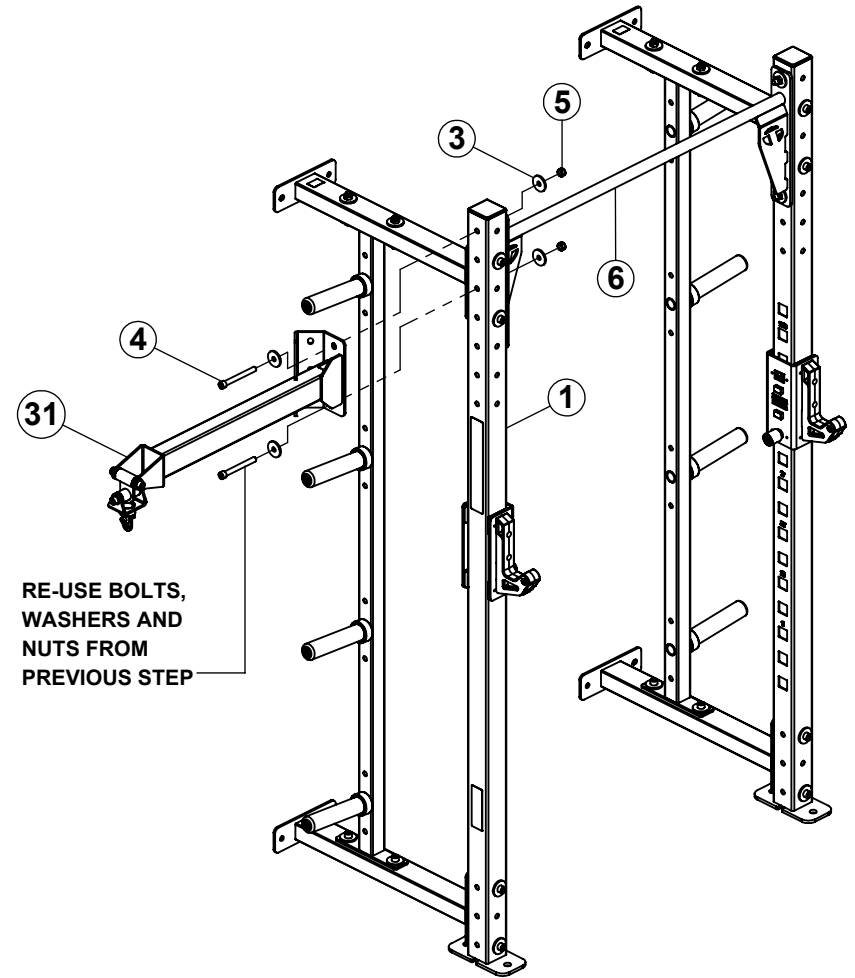

RE-USE BOLTS, WASHERS AND NUTS FROM PREVIOUS STEP

NOTE:

SECURELY tighten all bolt connections in this step.

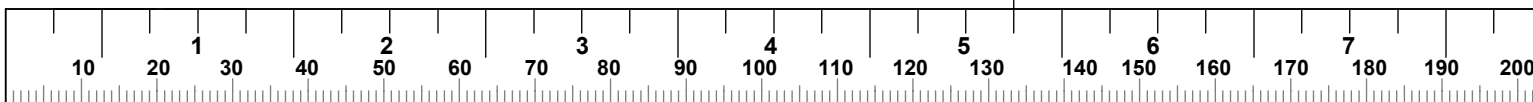

**STEP 14C (OPTIONAL UNIVERSAL HEAVY BAG MOUNT,
WITH VERTICAL WEIGHT STORAGE)**

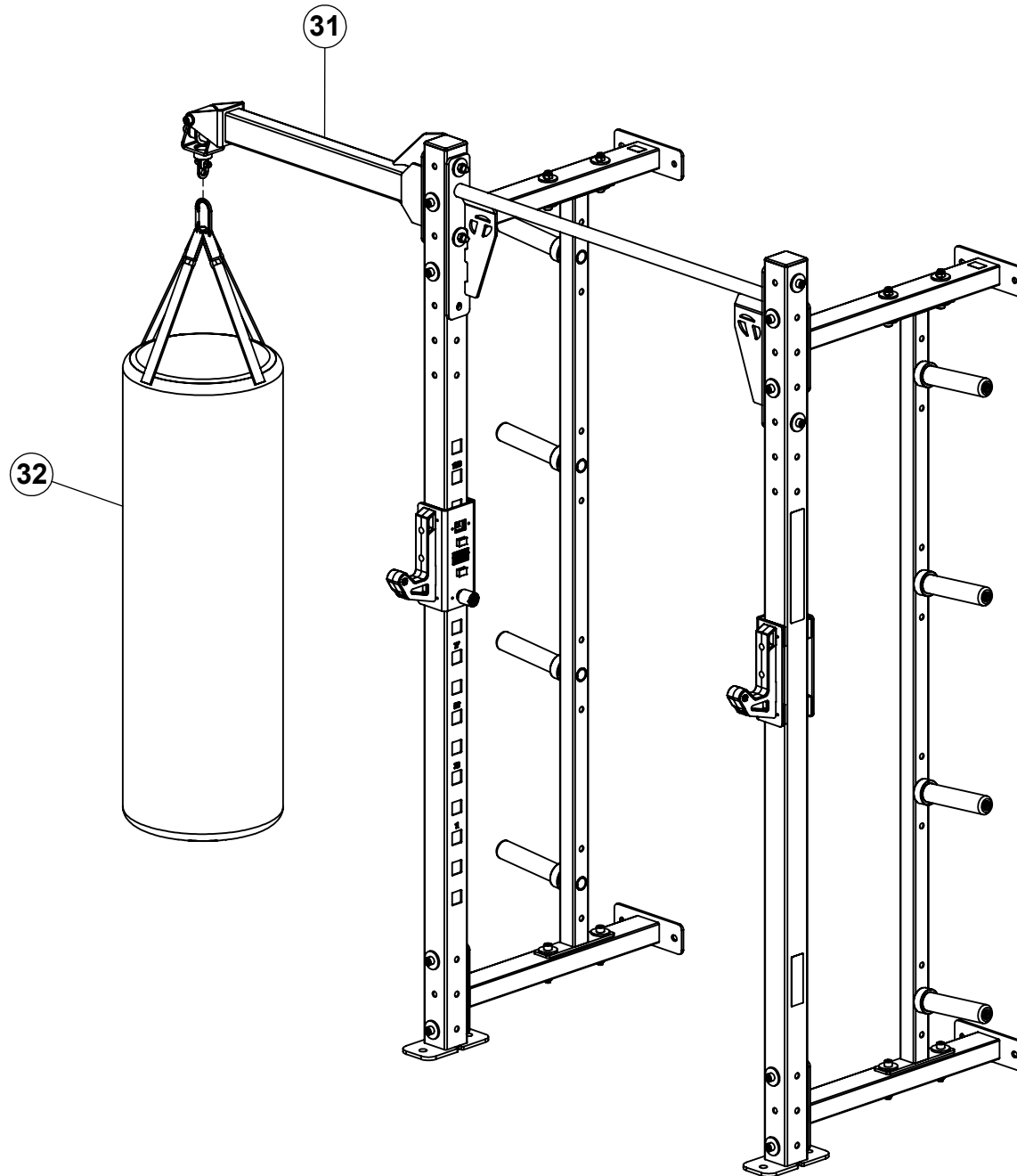

STEP 15A & 15B (OPTIONAL UNIVERSAL HEAVY BAG MOUNT WITHOUT VERTICAL WEIGHT STORAGE)

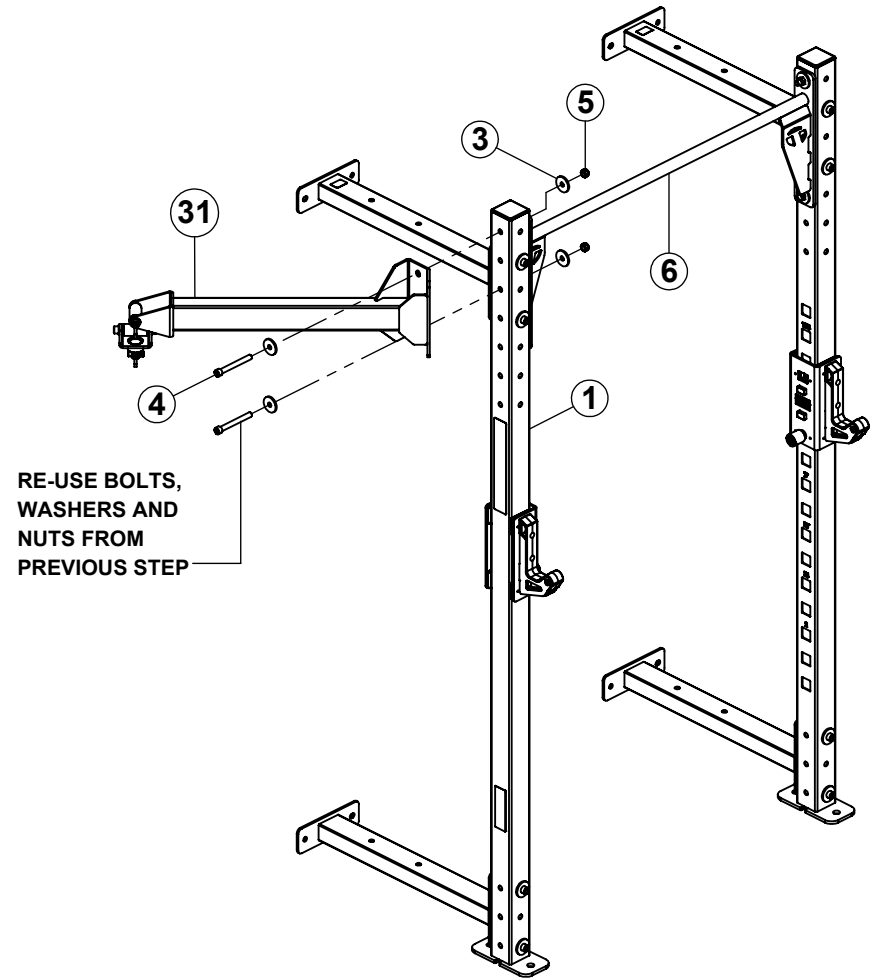
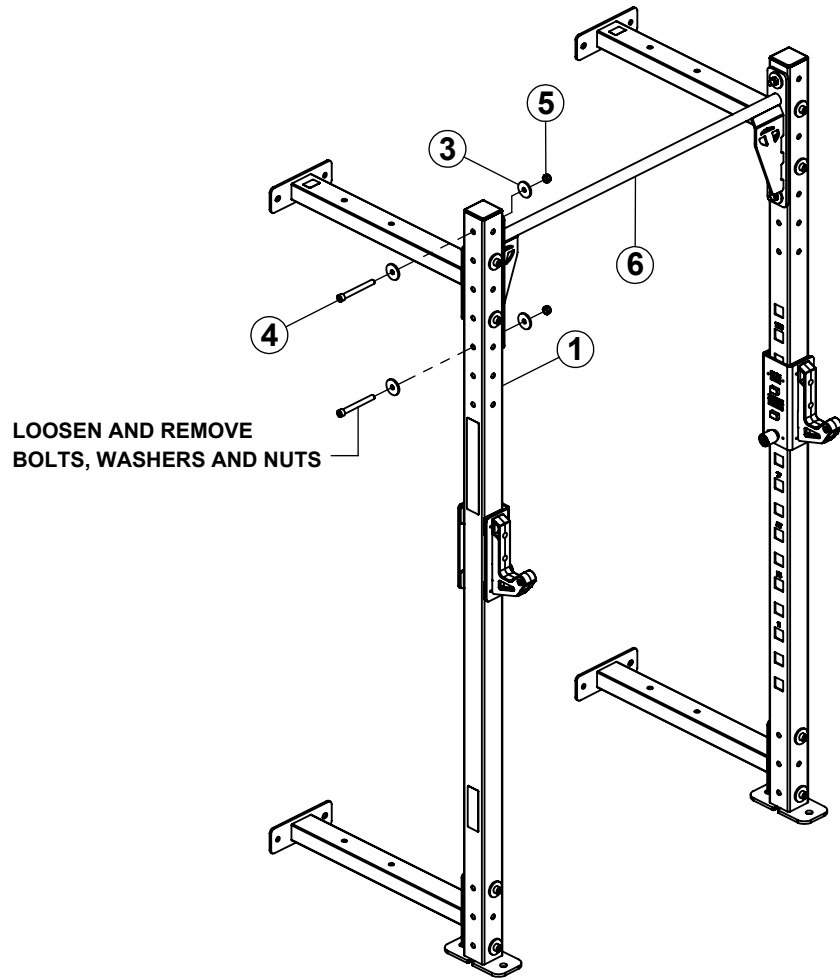

NOTE:

SECURELY tighten all bolt connections in this step.

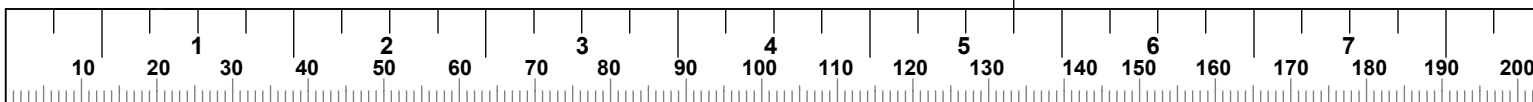

**STEP 15C (OPTIONAL UNIVERSAL HEAVY BAG MOUNT
WITHOUT VERTICAL WEIGHT STORAGE)**

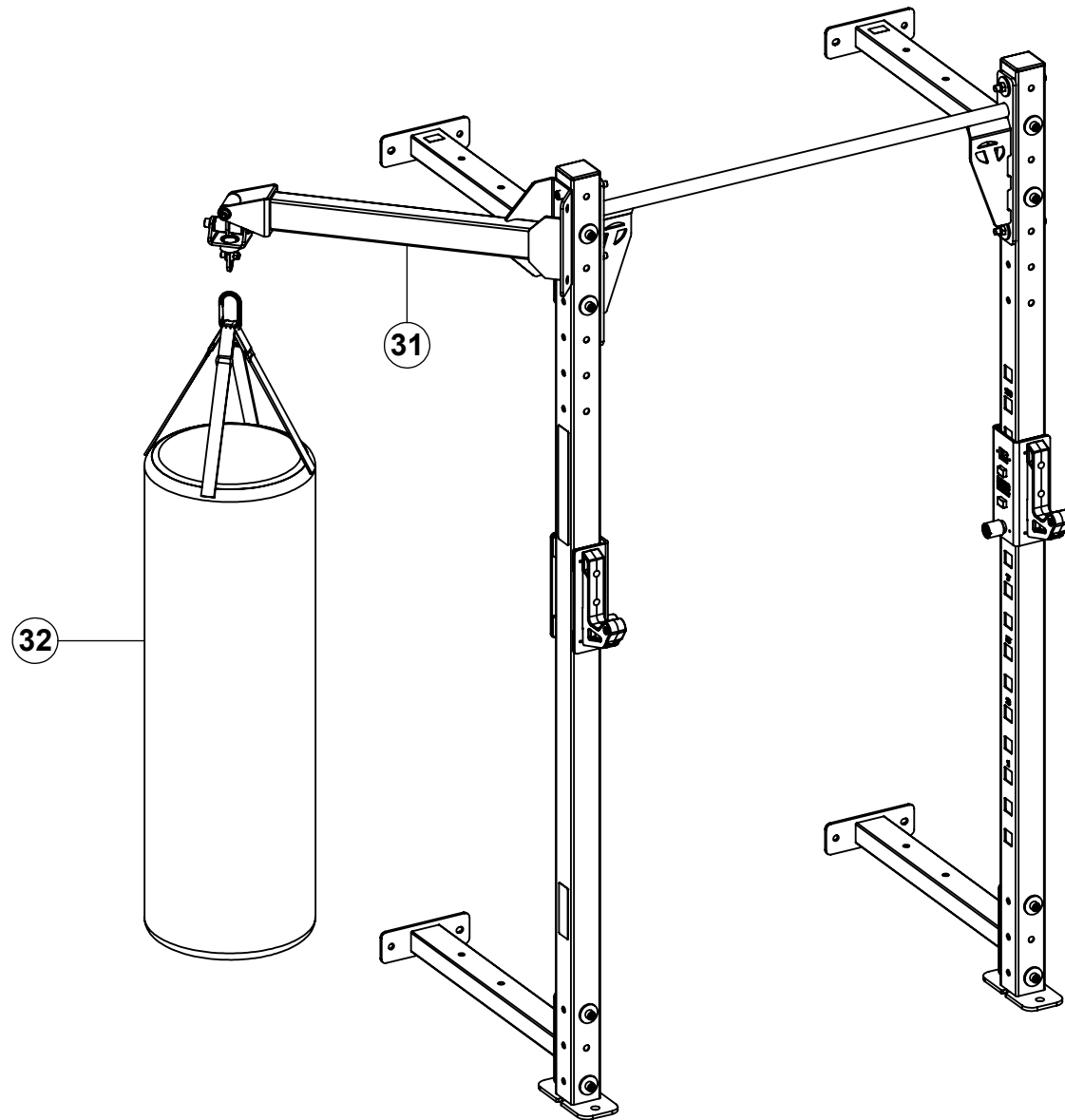

STEP 16A & 16B (OPTIONAL BATTLE ROPE ANCHOR)

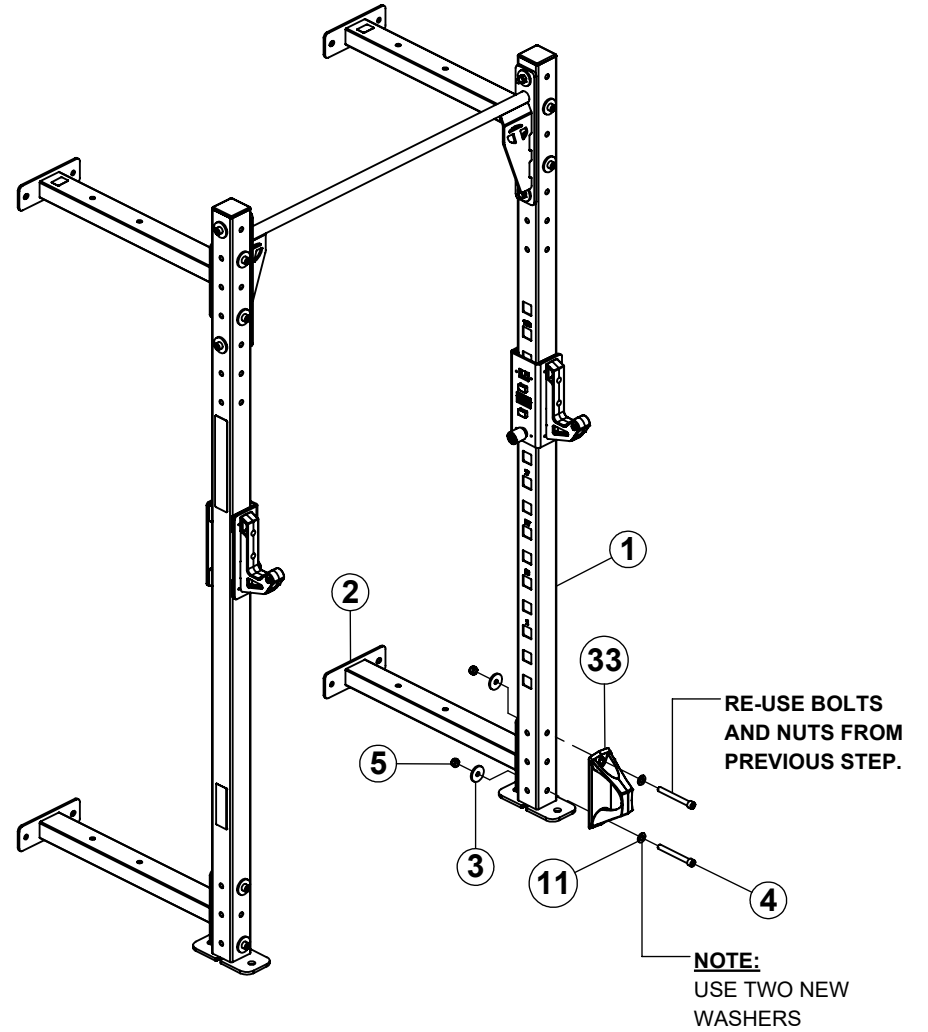
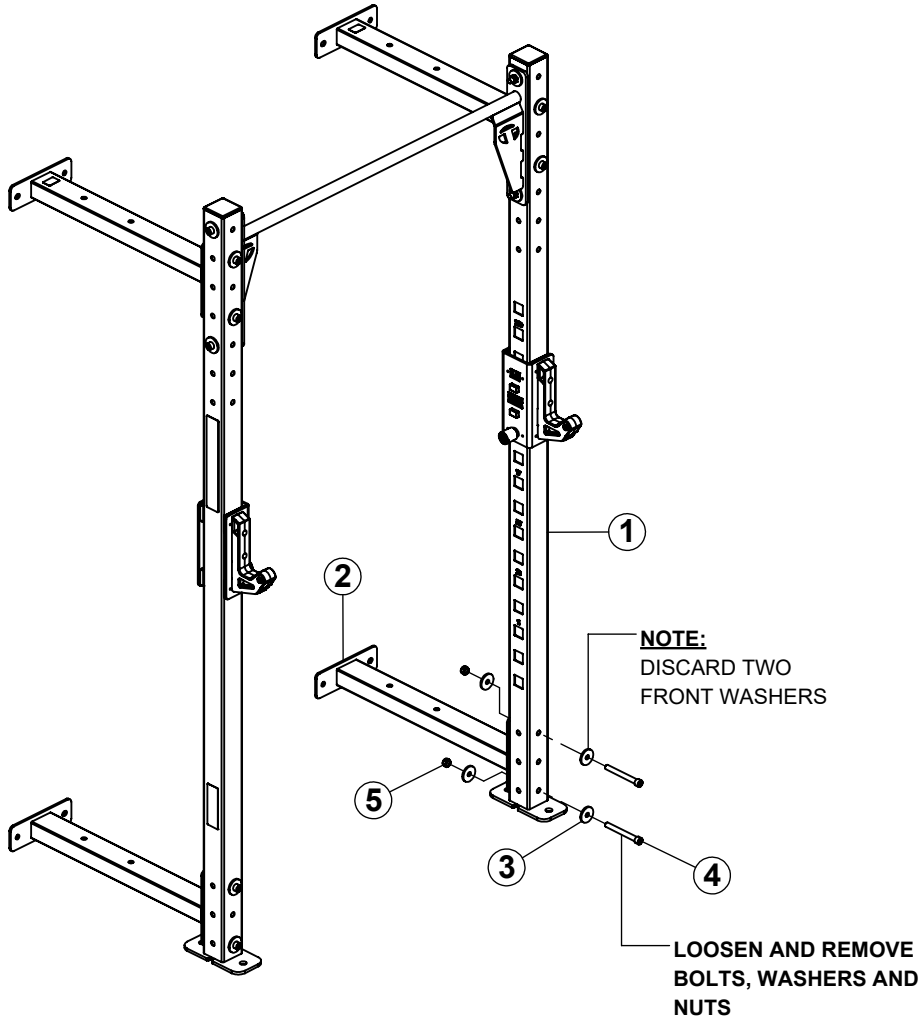

NOTE:

SECURELY tighten all bolt connections in this step.

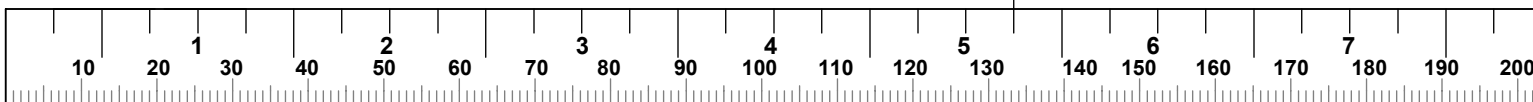

STEP 17A & 17B (OPTIONAL GROUND ROTATIONAL TRAINER)

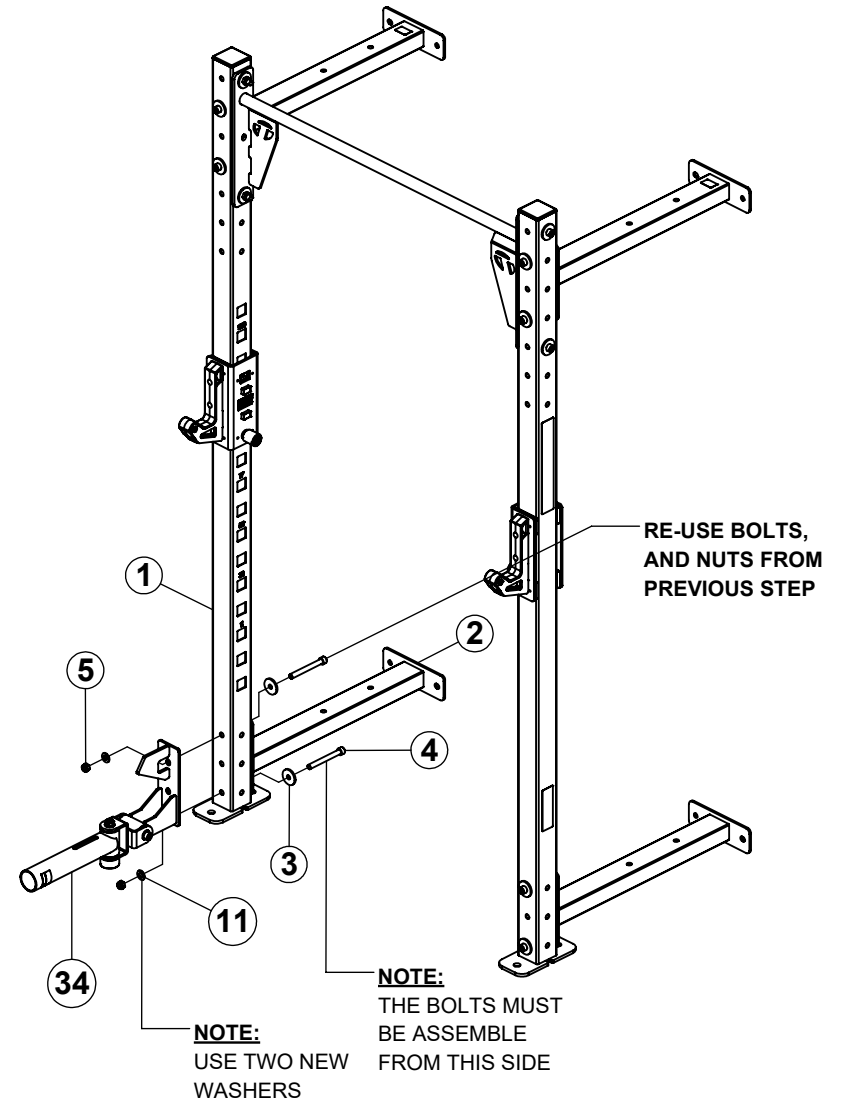
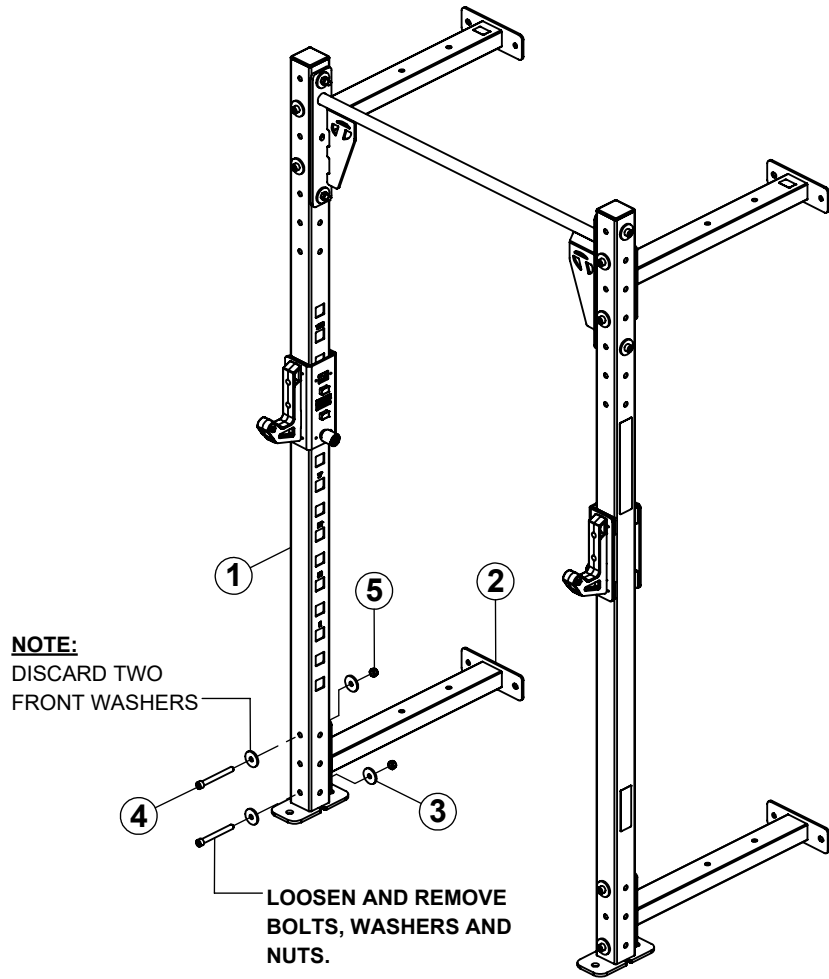

NOTE:
SECURELY tighten all bolt connections in this step.

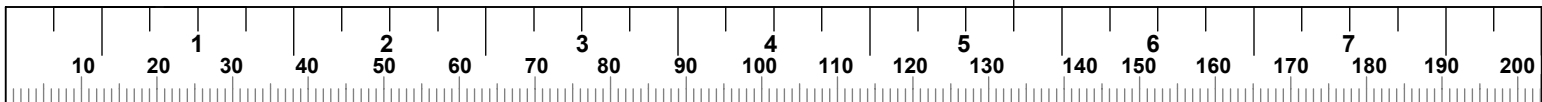

STEP 18A & 18B (OPTIONAL LOWER BAND PEG ATTACHMENT)

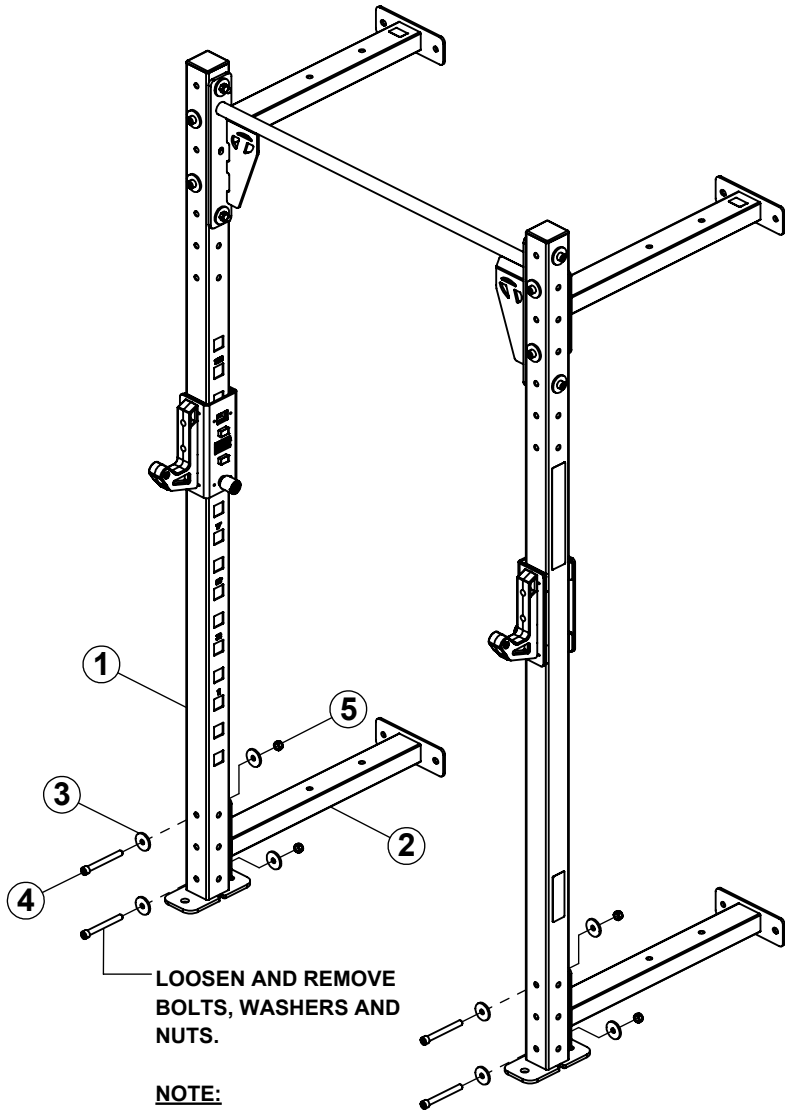

LOOSEN AND REMOVE BOLTS, WASHERS AND NUTS.

NOTE:
ASSEMBLE ONE SIDE AT A TIME

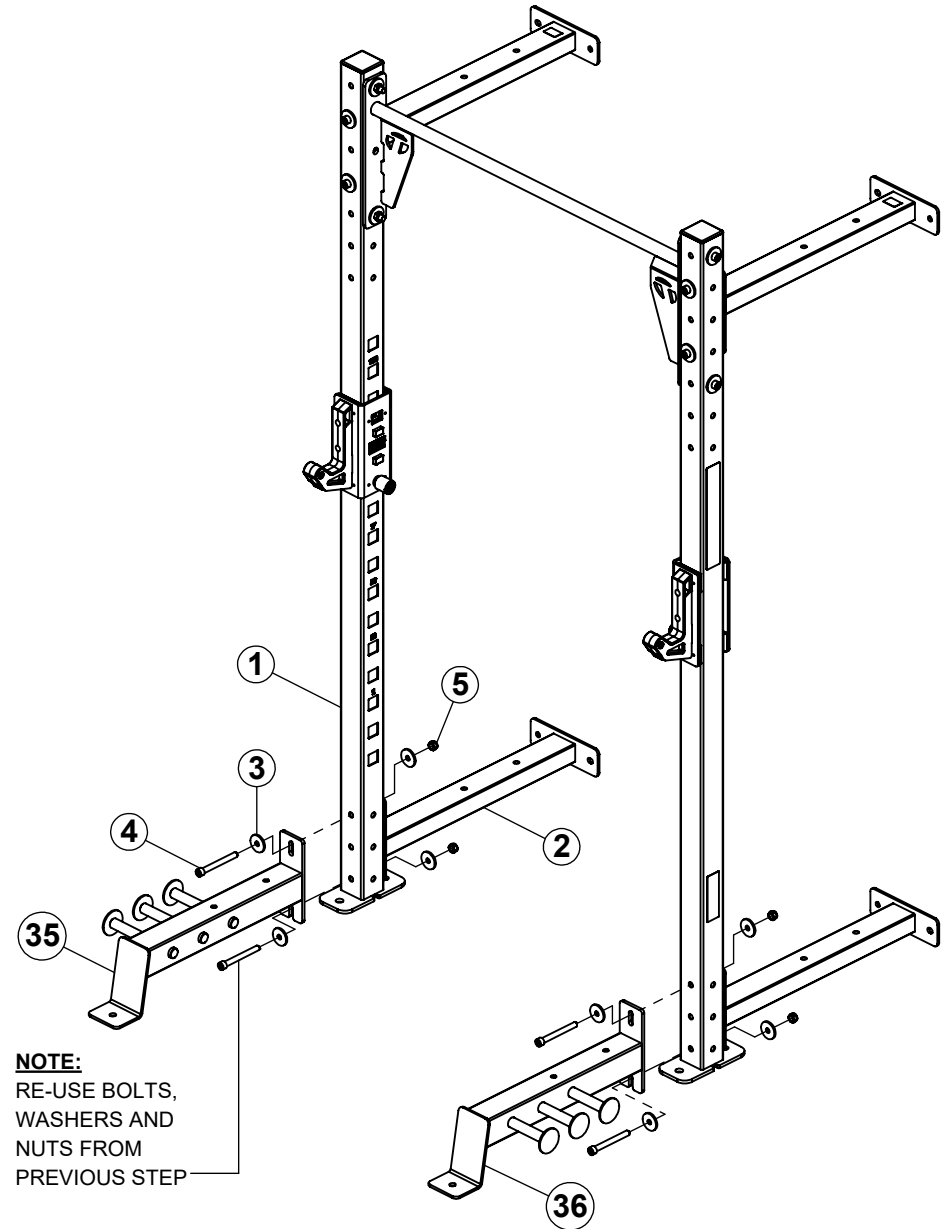

NOTE:
RE-USE BOLTS, WASHERS AND NUTS FROM PREVIOUS STEP

NOTE:

SECURELY tighten all bolt connections in this step.

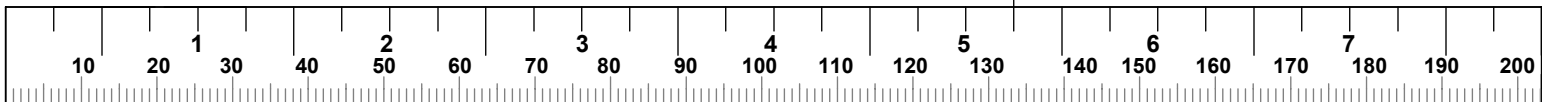

STEP 19 (OPTIONAL HORIZONTAL MOUNT GROUND ROTATIONAL TRAINER TO LOWER BAND PEG ATTACHMENT)

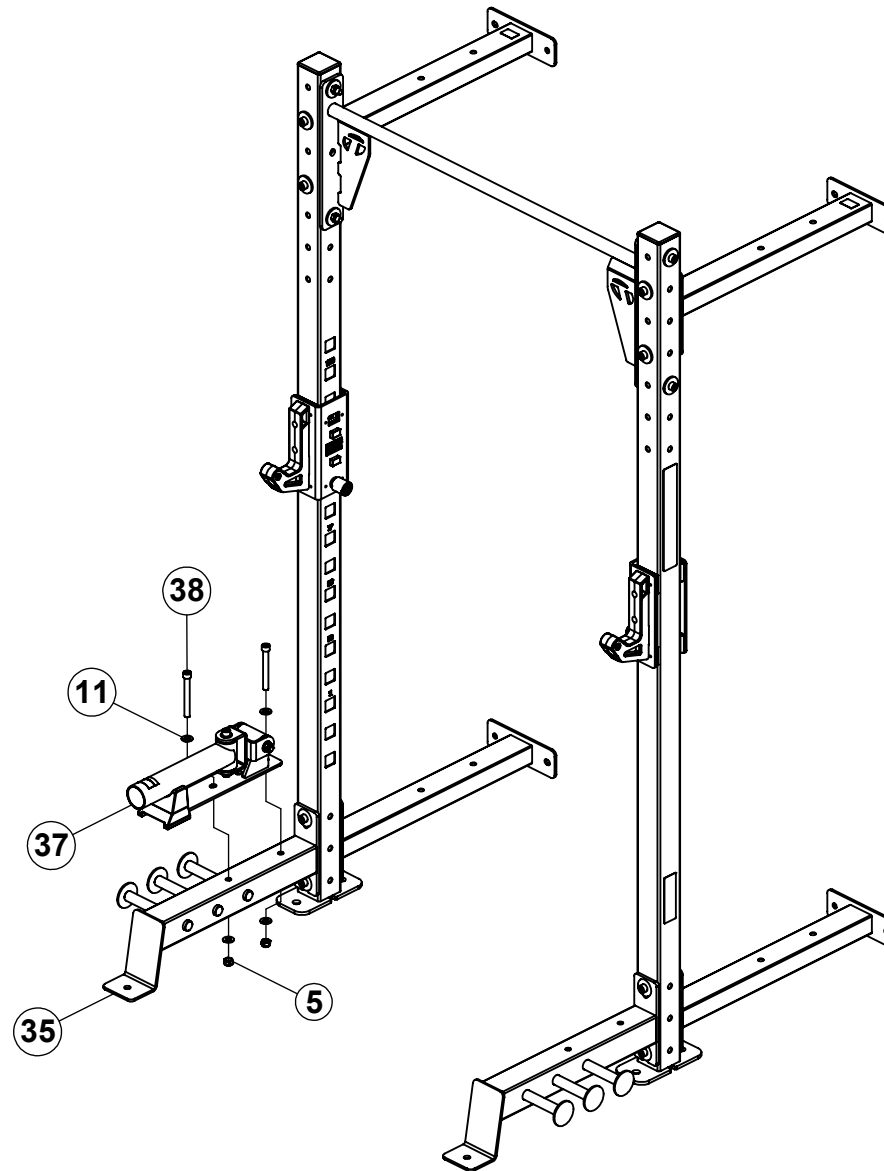

NOTE:

SECURELY tighten all bolt connections in this step.

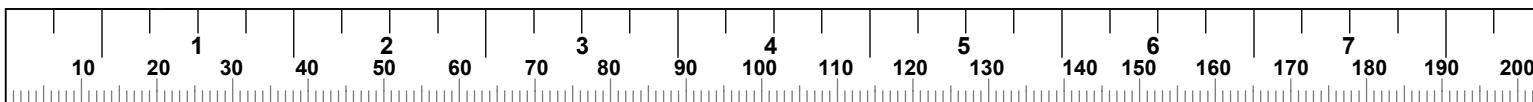

STEP 20 (OPTIONAL BATTLE ROPE ANCHOR TO LOWER BAND PEG ATTACHMENT)

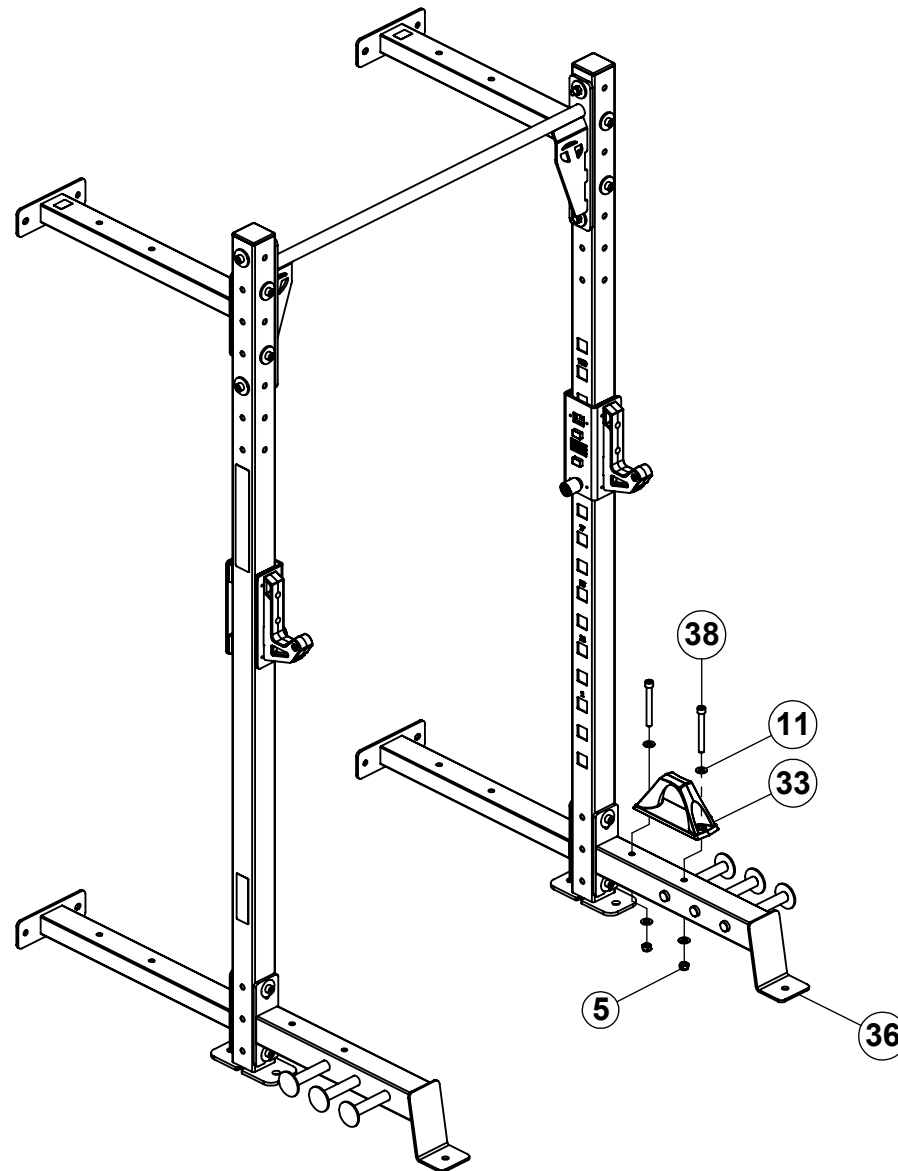

NOTE:

SECURELY tighten all bolt connections in this step.

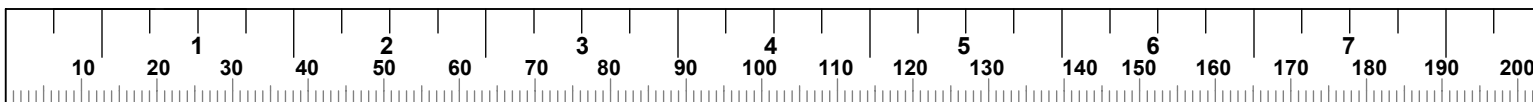

STEP 21 (OPTIONAL DOUBLE PLAY ATTACHMENT)

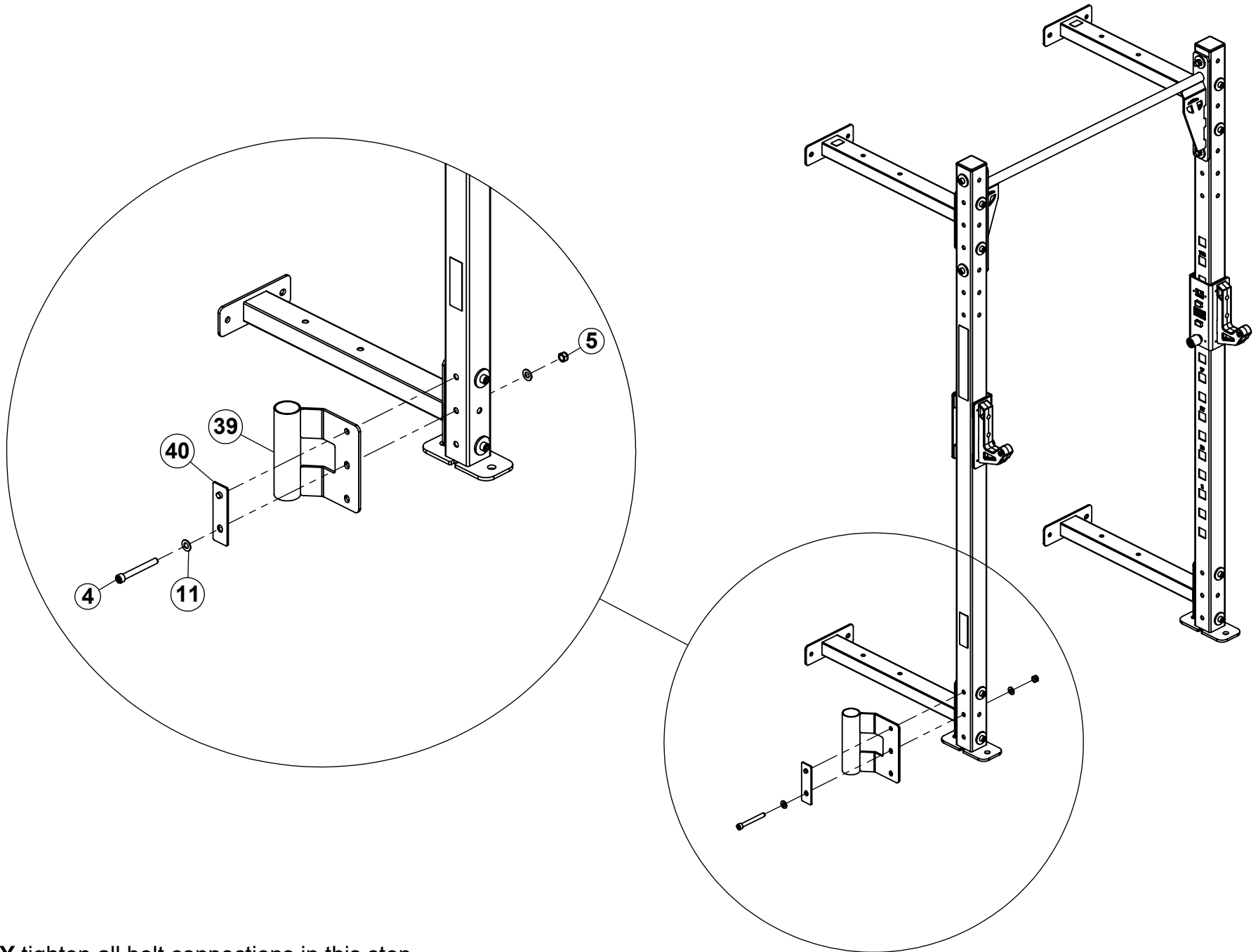

NOTE:

SECURELY tighten all bolt connections in this step.

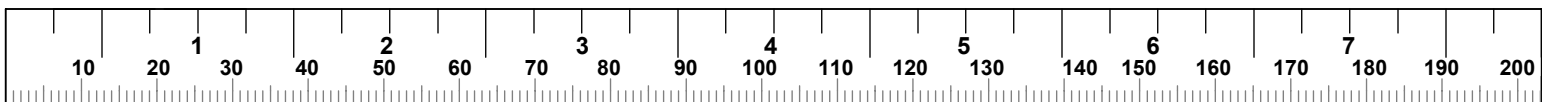

STEP 22A & 22B (OPTIONAL VERTICAL DUMBBELL STORAGE)

NOTE:
BOLTS MUST BE
INSTALLED IN
THIS DIRECTION

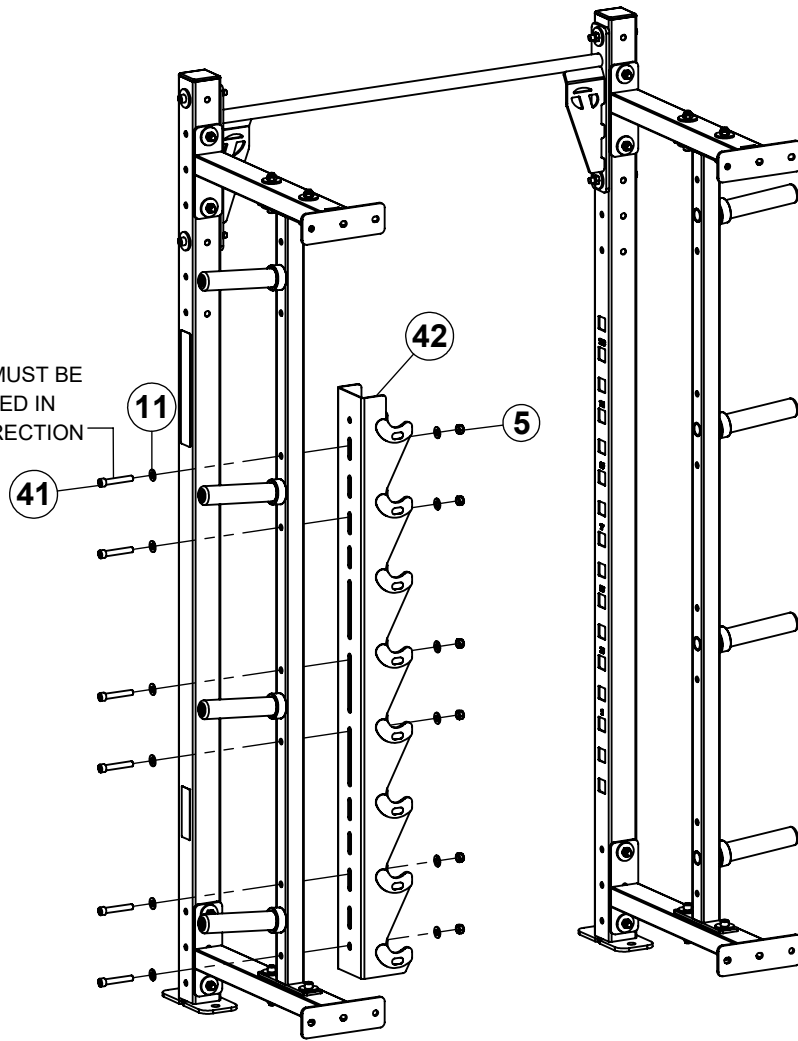

NOTE:
BOLTS MUST BE
INSTALLED IN
THIS DIRECTION

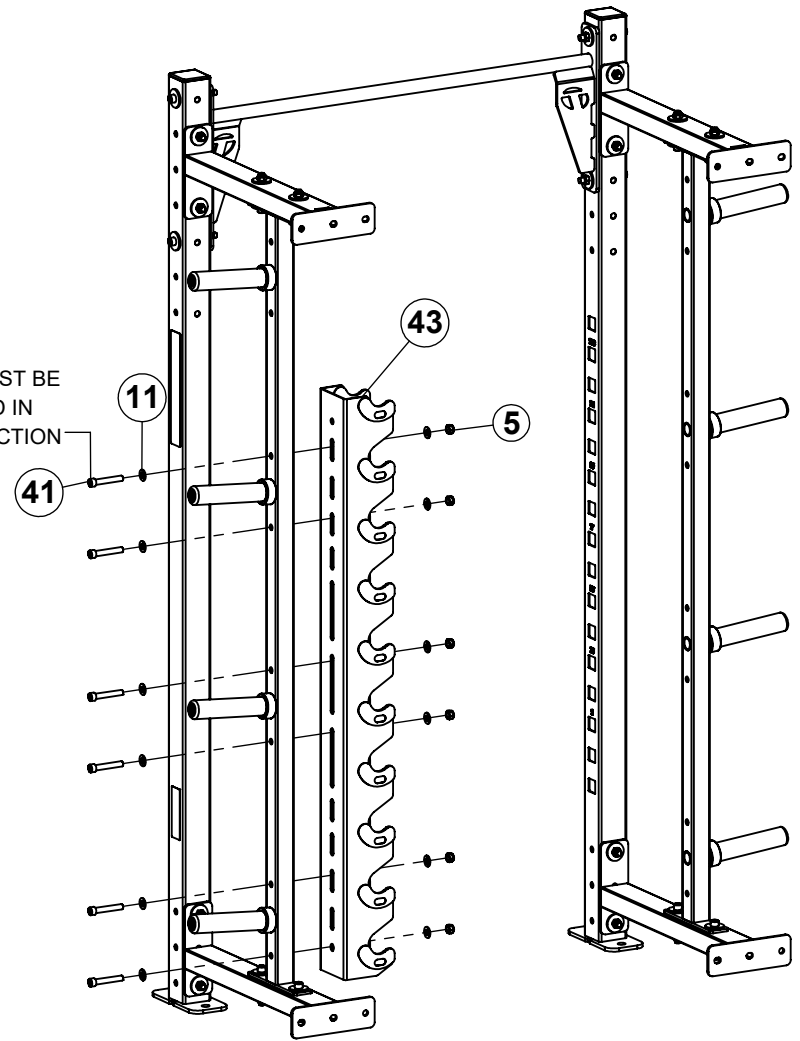

NOTE:

SECURELY tighten all bolt connections in this step.

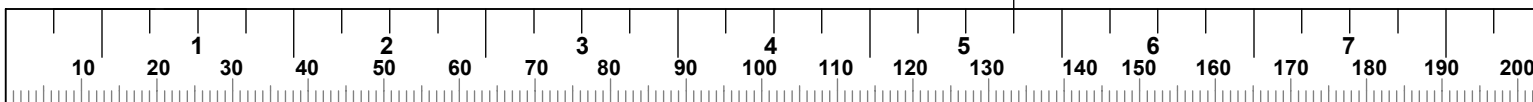

MAINTENANCE:

- **NUTS/BOLTS:** Inspect periodically, tighten and/or adjust as needed.
- **SPRING PINS:** Check that spring pins fully engage the hole when released. Tighten spring pin nuts as needed.
- **FRAME:** Wipe down frame with a damp cloth.

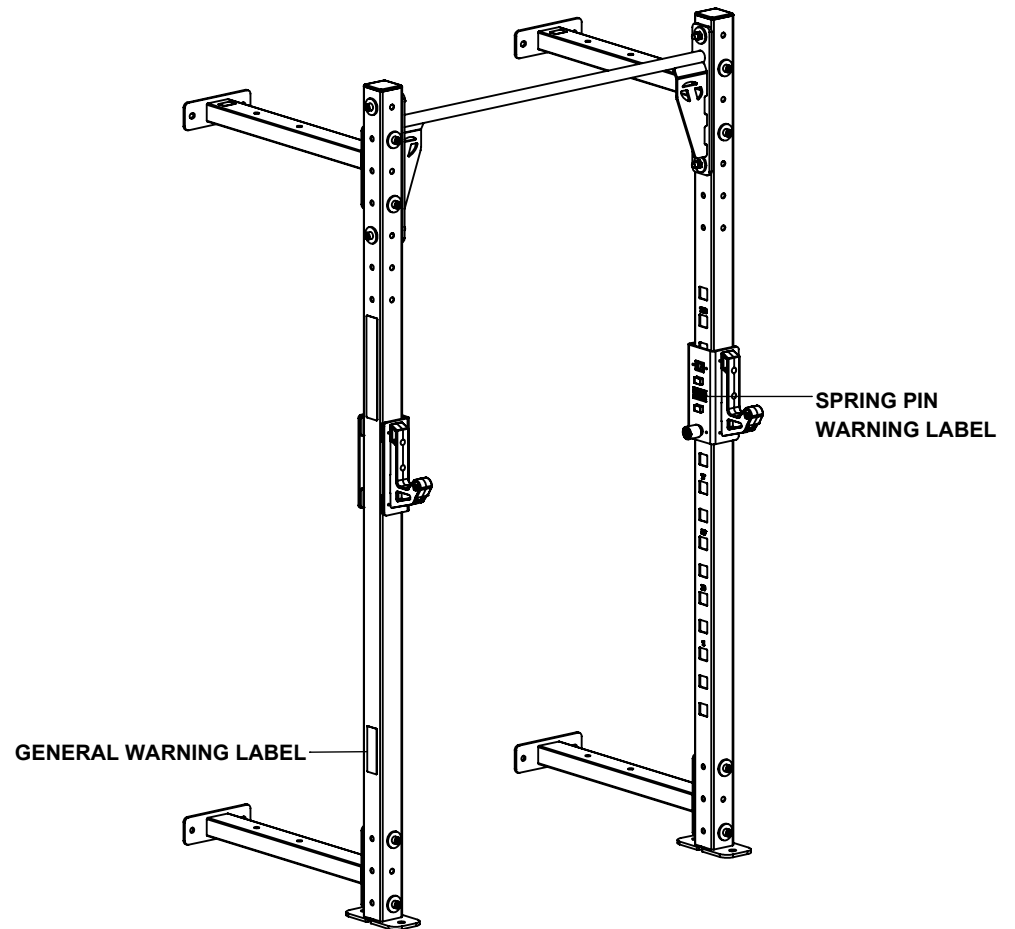

Torque Fitness
11201 Xeon Street NW Ste 101
Coon Rapids, MN USA 55448

www.torquefitness.com
or 763-754-7533 (8:30 am – 5:00 CST).

For sales: sales@torquefitness.com
For service: service@torquefitness.com

 <https://twitter.com/TorqueFitnessHQ>

 <https://www.instagram.com/torquefitnessusa/>

 <https://www.youtube.com/c/TorqueFitness/>

 <https://www.facebook.com/torquefitness/>