

Installation Guide | Directline Derailleur Pulleys

Directline

- 1** Disconnect the shift cable or wire if applicable

- 2** Release Clutch on equipped Shimano Derailleurs

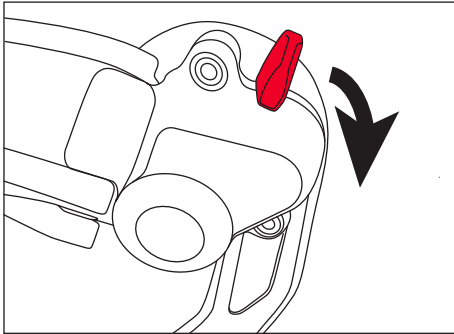

- 2** Release Clutch on equipped SRAM Derailleurs

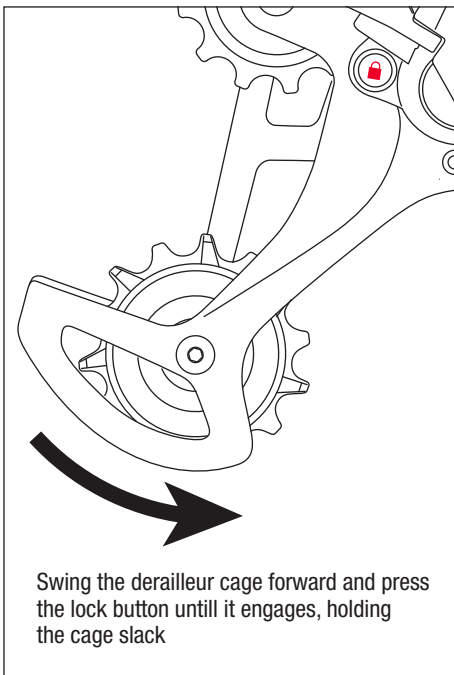

- 3** Break the Chain at the masterlink or with chain tool

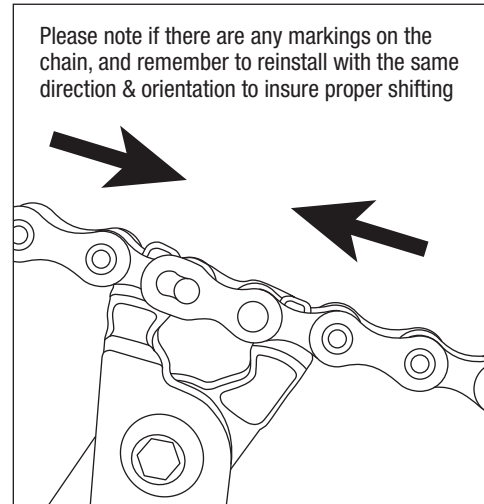

Pro tip: Mark the outside plate of link next to the masterlink with a marker to match orientation for reinstallation

- 4** Remove the Derailleur from the hanger with appropriate tool (usually 5mm allen)

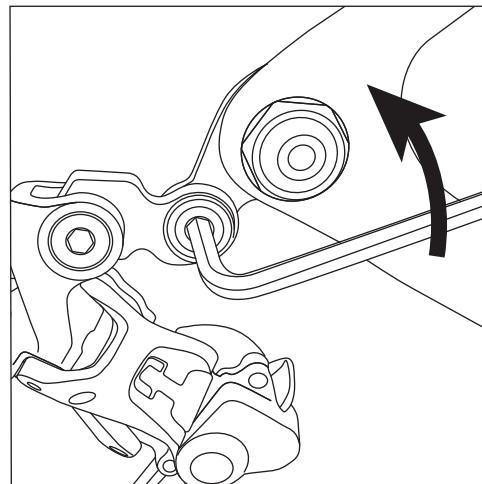

- 5** Remove and Replace the Lower Pulley from the front of the derailleur with appropriate tool (usually 3mm allen)

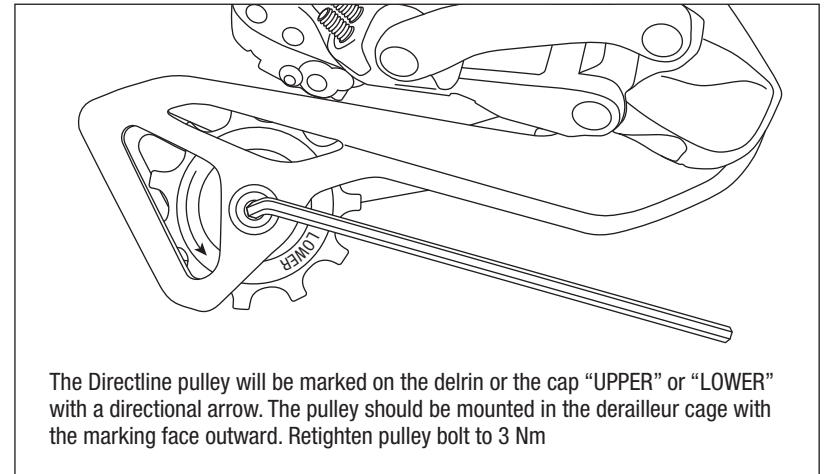

- 6** Remove and Replace the Upper Pulley from the back of the derailleur (sometimes the front) with appropriate tool (usually 3mm allen)

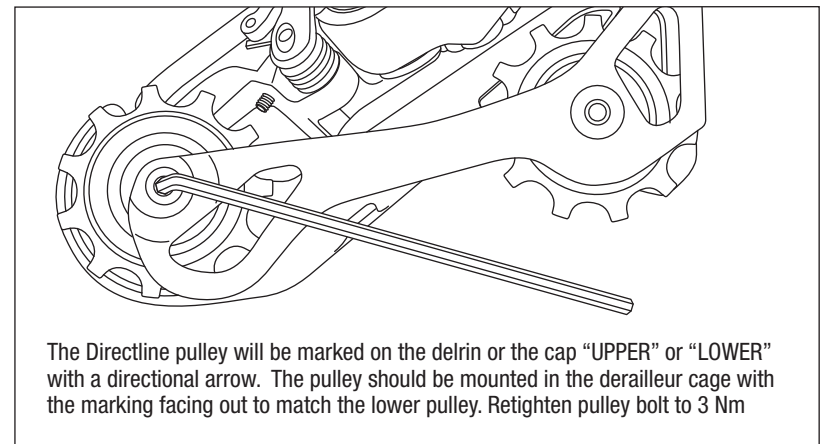

- 7** Reinstall derailleur, chain and check shifting
Torque derailleur mounting bolt to 8 Nm and ensure that the chain moves freely through the cage. Reconnect the shift cable or wire, test shifting and adjust if necessary